REPLACEMENT PARTS MANUAL

OIL FIRED FURNACE

Models:

FLF075V42A FLR100V48A FLF110V48A FLR130V60A
FLR075V42A FLR100V60A FLF110V60A

General Notes

- Revised and/or additional pages may be issued from time to time.
- A complete and current manual consists of pages shown in the following contents section.

Important

- Contact the installing and/or local Bard distributor for all parts requirements. Make sure to have the complete model and serial number available from the unit rating plates.

Contents

<u>Description</u>	<u>Page</u>
Cabinet and Functional Components	
♦ Exploded View	2
♦ Usage List	3
♦ Usage List	4
♦ Usage List	5
Control Panel	
♦ Layout View	6
♦ Usage List	7
Blower Assembly	
♦ Exploded View	8
♦ Usage List	9
Burner Assembly	
♦ Exploded View	10
♦ Usage List	11
Burner Components	
♦ Exploded View	12
♦ Usage List	13



Climate Control Solutions

Bard Manufacturing Company, Inc.
Bryan, Ohio 43506
www.bardhvac.com

Manual: 2110-931D
Supersedes: 2110-931C
Date: 6-14-17

CABINET AND FUNCTIONAL COMPONENTS

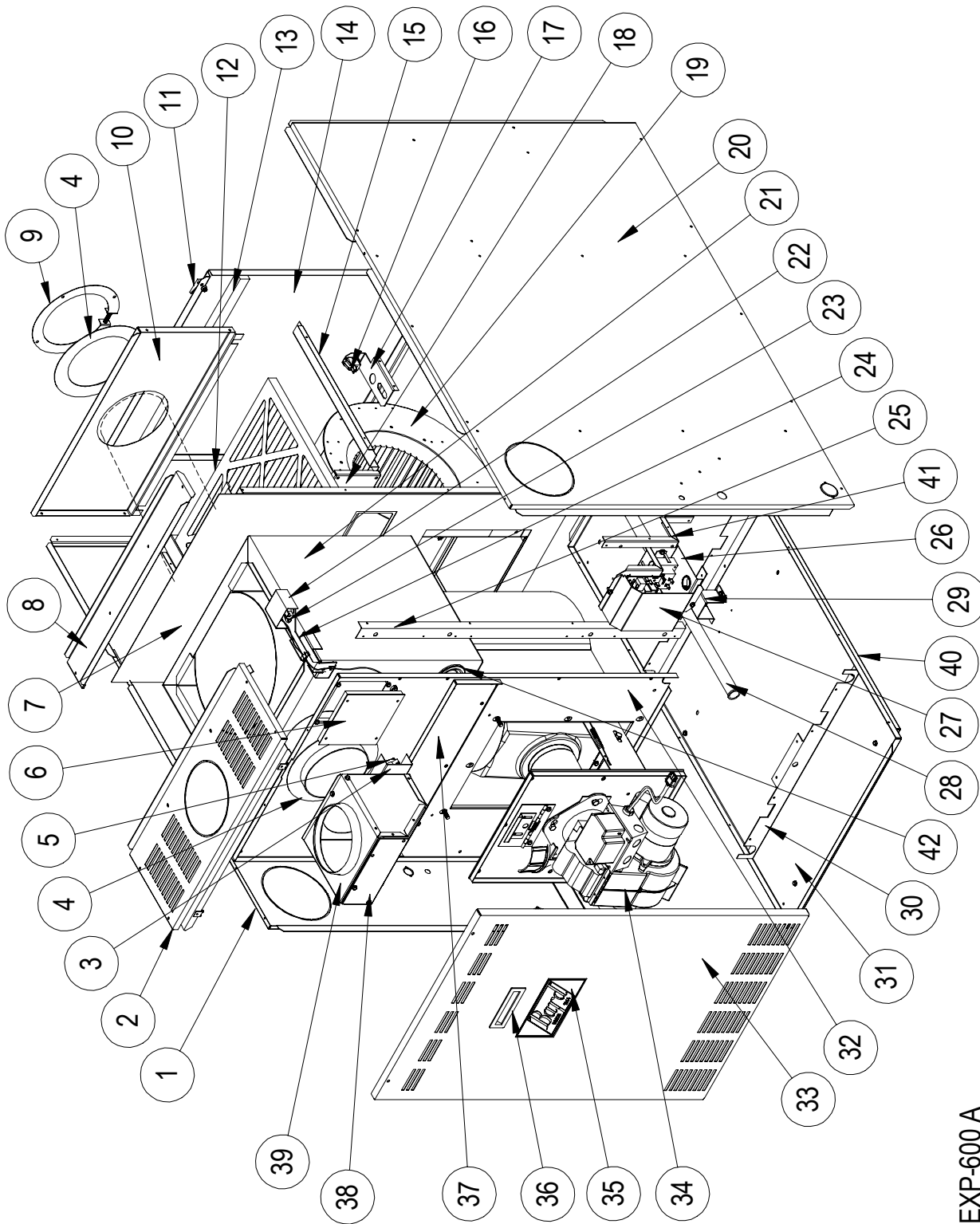

SEXP-600 A

CABINET AND FUNCTIONAL COMPONENTS

Drawing No.	Part Number	Description	FLF075V42A	FLR075V42A	FLF110V48A	FLR100V48A	FLF110V60A	FLR100V60A	FLR130V60A
1	S101-412-4	Left Side Assembly	X	X					
1	S101-414-4	Left Side Assembly			X	X	X	X	
1	S101-416-4	Left Side Assembly							X
2	S107-231-4	Top Fill Assembly	X	X	X	X	X	X	
2	S107-233-4	Top Fill Assembly							X
3	143-094	Partition Limit Cover	X	X	X	X	X	X	X
4	1921-037	Smokepipe Gasket	X	X	X	X	X	X	X
5	8402-147	Backup Limit L190	X		X		X		
5	8402-148	Backup Limit L325		X		X		X	X
6	S142-089	Limit Access Door	X	X	X	X	X	X	X
7	S121-367	Blower Partition	X						
7	S121-363	Blower Partition		X					
7	S121-370	Blower Partition			X		X		
7	S121-364	Blower Partition				X		X	
7	S121-371	Blower Partition							X
8	165-577-4	Top Channel	X	X	X	X	X	X	
8	165-579-4	Top Channel							X
9	166-019	Smokepipe Clamp		X		X		X	X
10	109-172-4	Upper Back	X		X		X		
10	109-171-4	Upper Back		X		X		X	
10	109-173-4	Upper Back							X
11	1171-053	Swell Latch	X	X	X	X	X	X	X
12	7004-035	16 x 20 x 2 Pleated Filter	X	X					
12	7004-052	20 x 20 x 2 Pleated Filter			X	X			
12	7004-040	20 x 25 x 2 Pleated Filter							X
12	7003-041	20 x 20 x 1 Alum Mesh					X	X	
13	1913-006-2200	Foam Seal	X	X	X	X	X	X	
13	1913-006-2500	Foam Seal							X
14	S153-365-4	Blower Door Assembly	X	X					
14	S153-364-4	Blower Door Assembly			X	X	X	X	
14	S153-359-4	Blower Door Assembly							X
15	131-138	Filter Support	X	X					
15	131X139	Right Filter Support			X	X	X	X	
15	131Y139	Left Filter Support			X	X	X	X	
15	131X140	Right Filter Support							X
15	131Y140	Left Filter Support							X
16	8406-076	Door Switch	X	X	X	X	X	X	X
17	112-300	Plug Bracket	X	X	X	X	X	X	X

Table continued on page 4

CABINET AND FUNCTIONAL COMPONENTS

Table continued from page 3

Drawing No.	Part Number	Description	FLF075V42A	FLR075V42A	FLF110V48A	FLR100V48A	FLF110V60A	FLR100V60A	FLR130V60A
18	S143-092	Rear Cleanout Cover	X	X	X	X	X	X	
18	S143-096	Rear Cleanout Cover							X
19	S900-322-001	Blower Assembly	X	X					
19	S900-332-001	Blower Assembly			X	X			
19	S900-323-001	Blower Assembly					X	X	
19	S900-325-001	Blower Assembly							X
20	S101-411-4	Right Side Assembly	X	X					
20	S101-413-4	Right Side Assembly			X	X	X	X	
20	S101-415-4	Right Side Assembly							X
21	S171-267	Heat Exchanger Assembly	X						
21	S171-269	Heat Exchanger Assembly		X					
21	S171-268	Heat Exchanger Assembly			X		X		
21	S171-270	Heat Exchanger Assembly				X		X	
21	S171-271	Heat Exchanger Assembly							X
22	143-091	Primary Limit Cover	X	X	X	X	X	X	X
23	8402-079	Primary Limit L200				X		X	
23	8402-161	Primary Limit L210		X					
23	8402-146	Primary Limit L185							X
23	8402-154	Primary Limit L165	X		X		X		
24	112-312	Primary Limit Bracket	X	X	X	X	X	X	X
25	105-1141	Side Angle	X	X					
25	105-1142	Side Angle			X	X	X	X	
25	105-1147	Side Angle							X
26	166-019	Smokepipe Clamp		X		X		X	X
27	133-209	Control Panel Cover	X	X	X	X	X	X	X
28	8611-089	2.4 Feet Wire Channel	X	X	X	X	X	X	X
29	164-585	Rear Heat Exchanger Support	X	X	X	X	X	X	X
30	105-1318	Front Heat Exchanger Support	X	X	X	X	X	X	
30	104-1149	Front Heat Exchanger Support							X
31	127-330	Base	X	X	X	X	X	X	
31	127-331	Base							X
32	S121-497	Burner Partition	X						
32	S121-499	Burner Partition		X					
32	S121-366	Burner Partition			X		X		
32	S121-500	Burner Partition				X		X	
32	S121-498	Burner Partition							X

Table continued on page 5

CABINET AND FUNCTIONAL COMPONENTS

Table continued from page 4

Drawing No.	Part Number	Description	FLF075V42A	FLR075V42A	FLF110V48A	FLR100V48A	FLF110V60A	FLR100V60A	FLR130V60A
33	S153-354-4	Vestibule Door	X	X					
33	S153-355-4	Vestibule Door			X	X	X	X	
33	S153-358-4	Vestibule Door							X
34	9020-049	NX Oil Burner w/.50 GPH Nozzle	X						
34	9020-050	NX Oil Burner w/.50 GPH Nozzle		X					
34	9020-044	NX Oil Burner w/.85 GPH Nozzle			X		X		
34	9020-047	NX Oil Burner w/.75 GPH Nozzle				X		X	
34	9020-048	NX Oil Burner w/.85 GPH Nozzle							X
35	5252-010	Bard Nameplate	X	X	X	X	X	X	X
36	1171-025	Door Pull	X	X	X	X	X	X	X
37	S143-090	Front Cleanout Cover	X	X	X	X	X	X	
37	S143-095	Front Cleanout Cover							X
38	169-152	Flue Box Door	X	X	X	X	X	X	X
39	S169-150	Flue Box Assembly	X		X		X		
40	165-578	Base Channel	X	X	X	X	X	X	X
41	105-1225	Control Panel Support Angle	X	X	X	X	X	X	X
42	173-100	Cleanout Clamp Assembly (4 Req. per Heat Exchanger)	X	X	X	X	X	X	X

CONTROL PANEL

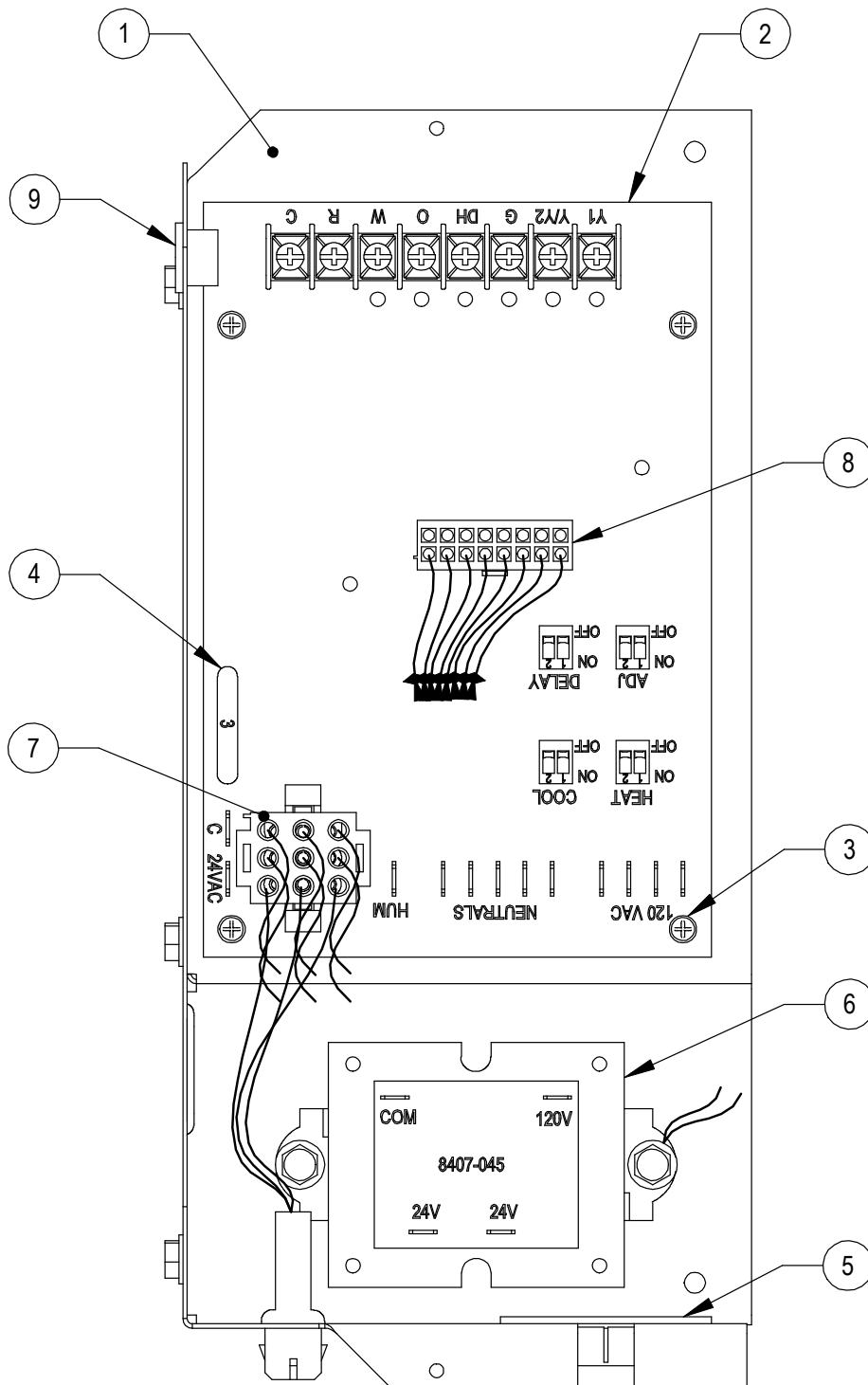

SEXP-597

CONTROL PANEL

Drawing No.	Part Number	Description	FLF075V42A	FLR075V42A	FLF110V48A	FLR100V48A	FLF110V60A	FLR100V60A	FLR130V60A
1	S117-301	Control Panel Box	X	X	X	X	X	X	X
2	8201-125	Oil Furnace Blower Control - Variable	X	X	X	X	X	X	X
3	1012-099	#6 - 32 x 3/4 Fillister HD Screw	4	4	4	4	4	4	4
4	8614-045	3 Amp Fuse	X	X	X	X	X	X	X
5	8611-026	1.750" Snap Bushing	2	2	2	2	2	2	2
6	8407-045	Transformer 120/24V 40 VA	X	X	X	X	X	X	X
7	3000-1362	Wire Assembly	X	X	X	X	X	X	X
8	3000-1363	Wire Assembly	X	X	X	X	X	X	X
9	8611-028	1/2" Snap Bushing	X	X	X	X	X	X	X

BLOWER ASSEMBLY

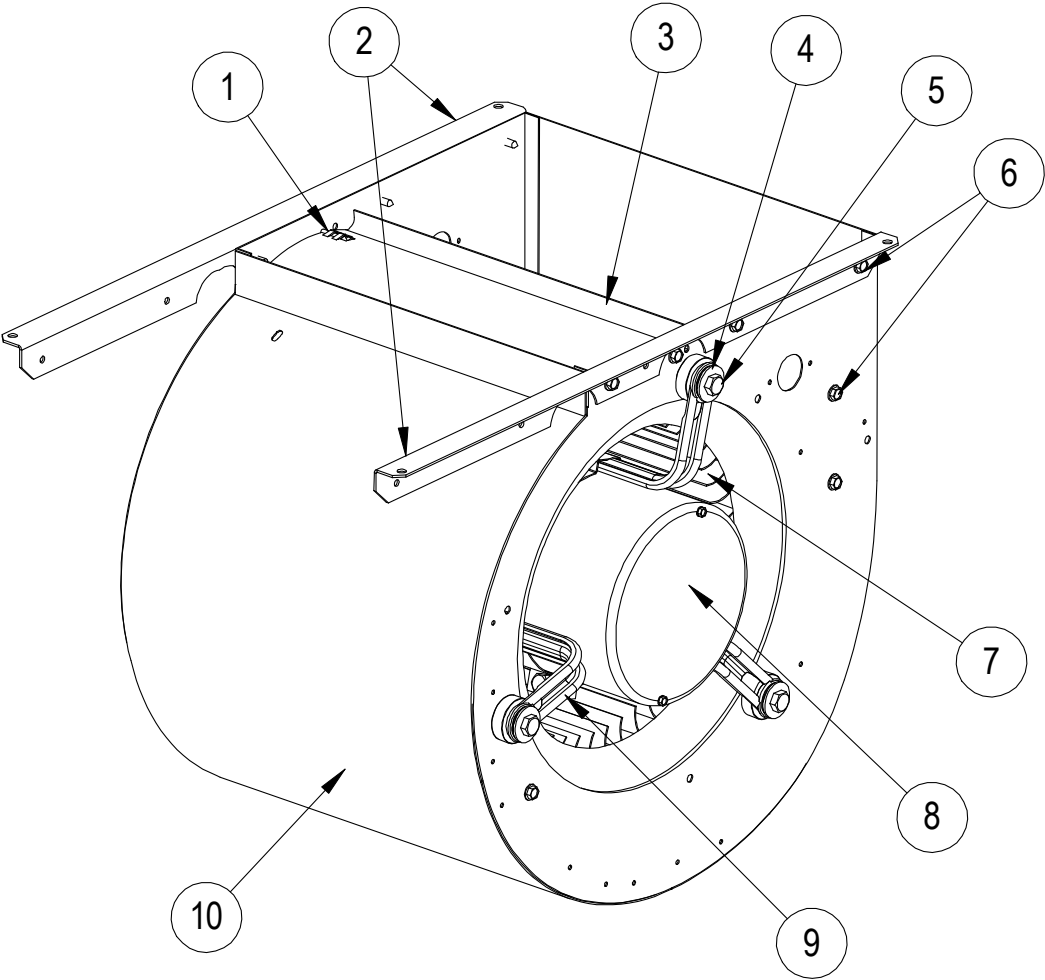

SEXP-598

BLOWER ASSEMBLY

Drawing No.	Part Number	Description	900-322-001	900-332-001	900-323-001	900-325-001
1	1012-088	Screw Type AB #10 – 16x3/4	2	2	①	①
2	104-1143	Blower Angle	2		2	2
2	104-1156	Blower Angle		2		
3	144-128	Diffuser	X		①	①
3	144-129	Diffuser		X		
4	1012-109	Washer	3	3	3	3
5	1012-076	1/4 – 20 x 1-1/4 Type I Bolt	3	3	3	3
6	1012-086	Screw Type AB #10 – 16x1/2 w/nibs	6	6	6	6
7	5152-014	Blower Wheel CW 1/2" 10-9DD	X			
7	5152-059	Blower Wheel CCW 1/2" 10-10DD		X		
7	5152-050	Blower Wheel CW 1/2" 11-10DD			X	X
8	S8106-051-0115	1/2 HP ECM Motor with Programmed Control	X			
8	S8107-016-0078	3/4 HP ECM Motor with Programmed Control		X		
8	S8108-009-0082	1 HP ECM Motor with Programmed Control			X	
8	S8108-009-0083	1 HP ECM Motor with Programmed Control				X
9	8620-034	Motor Mount Kit	X	X	X	X
10	151-073	Blower Housing	X			
10	151-082	Blower Housing		X		
10	①	Blower Housing			①	①

① Part #5152-050 includes housing, diffuser and blower wheel part #5152-053.

BURNER ASSEMBLY

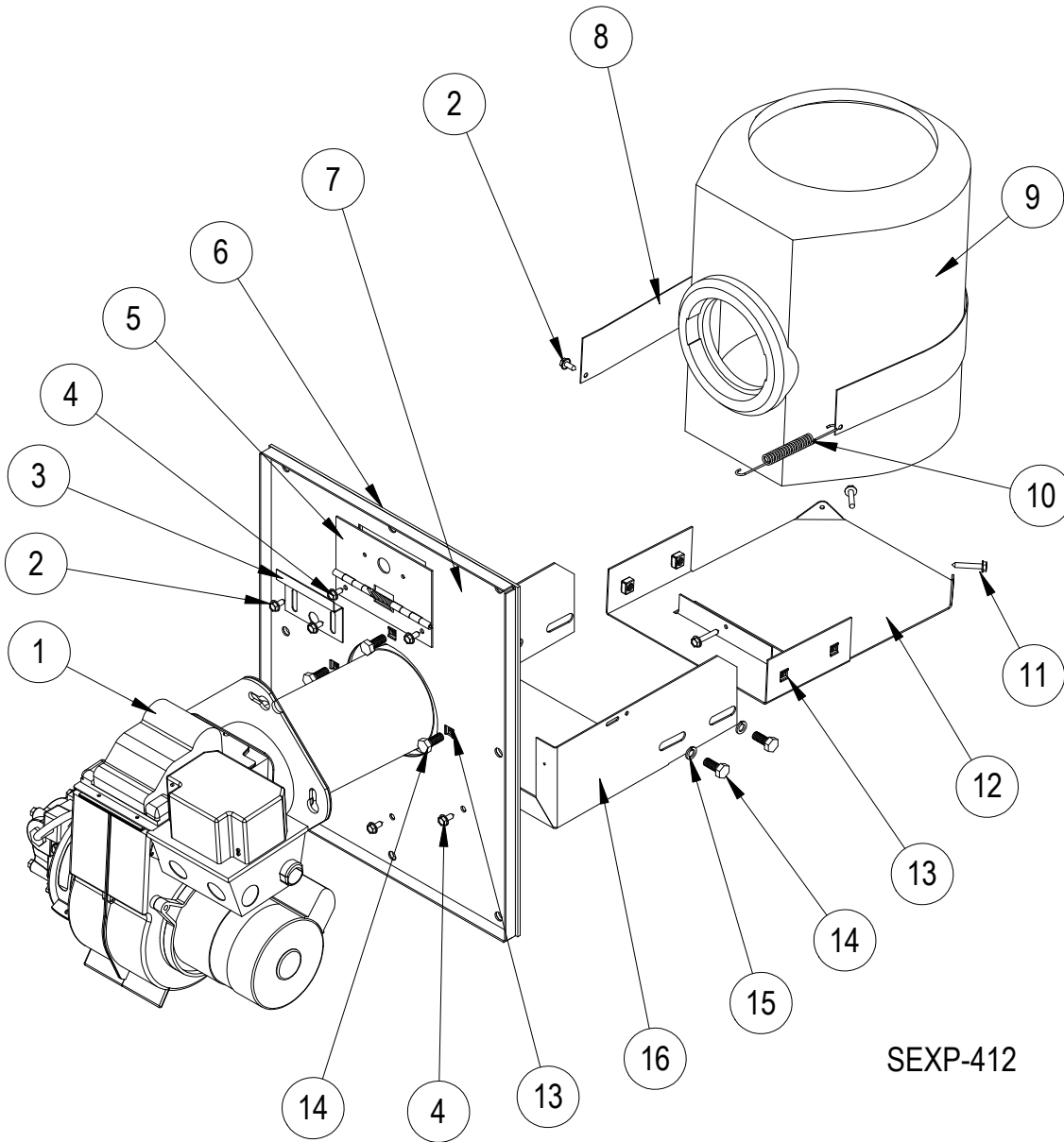

BURNER ASSEMBLY

Drawing No.	Part Number	Description	FLF075V42A	FLR075V42A	FLF110V48A	FLR100V48A	FLF110V60A	FLR100V60A	FLR130V60A
1	9020-049	NX Burner w/GeniSys Primary .50 GPH 60° Solid	X						
1	9020-050	NX Burner w/GeniSys Primary .50 GPH 60° Solid		X					
1	9020-044	NX Burner w/GeniSys Primary .85 GPH 60° Solid			X		X		
1	9020-047	NX Burner w/GeniSys Primary .75 GPH 60° Solid				X		X	
1	9020-048	NX Burner w/GeniSys Primary .85 GPH 60° Solid							X
2	1012-153	Screw Type AB #10 - 16x1/2"	3	3	3	3	3	3	3
3	143-026	Inspection Door Cover Plate	X	X	X	X	X	X	X
4	1012-086	Screw Type AB #10 - 16x1/2" w/nibs	5	5	5	5	5	5	5
5	142-027	Inspection Door Hinge	X	X	X	X	X	X	X
6	1921-066	Front Plate Gasket	X	X	X	X	X	X	
6	1921-065	Front Plate Gasket							X
7	S161-039	Front Plate Assembly	X	X	X	X	X	X	
7	S161-038	Front Plate Assembly							X
8	140-198	Combustion Chamber Support	X	X	X	X	X	X	
8	140-199	Combustion Chamber Support							X
9	7090-014	Pyrolite Combustion Chamber	X	X	X	X	X	X	
9	7090-013	Pyrolite Combustion Chamber							X
10	5401-004	Stainless Steel Spring	X	X	X	X	X	X	X
11	1012-145	Screw Type AB #10 - 16x1"	3	3	3	3	3	3	3
12	S140-292	Bracket Extension	X	X	X	X	X	X	
12	S140-302	Bracket Extension							X
13	1012-218	1/4 - 20 Cage Nut	7	7	7	7	7	7	7
14	1012-051	1/4 - 20x3/4 Hex Head Bolt	7	7	7	7	7	7	7
15	1012-126	1/4" Type "A" Washer	4	4	4	4	4	4	4
16	112-297	Combustion Chamber Bracket	X	X	X	X	X	X	
16	112-302	Combustion Chamber Bracket							X

BURNER COMPONENTS

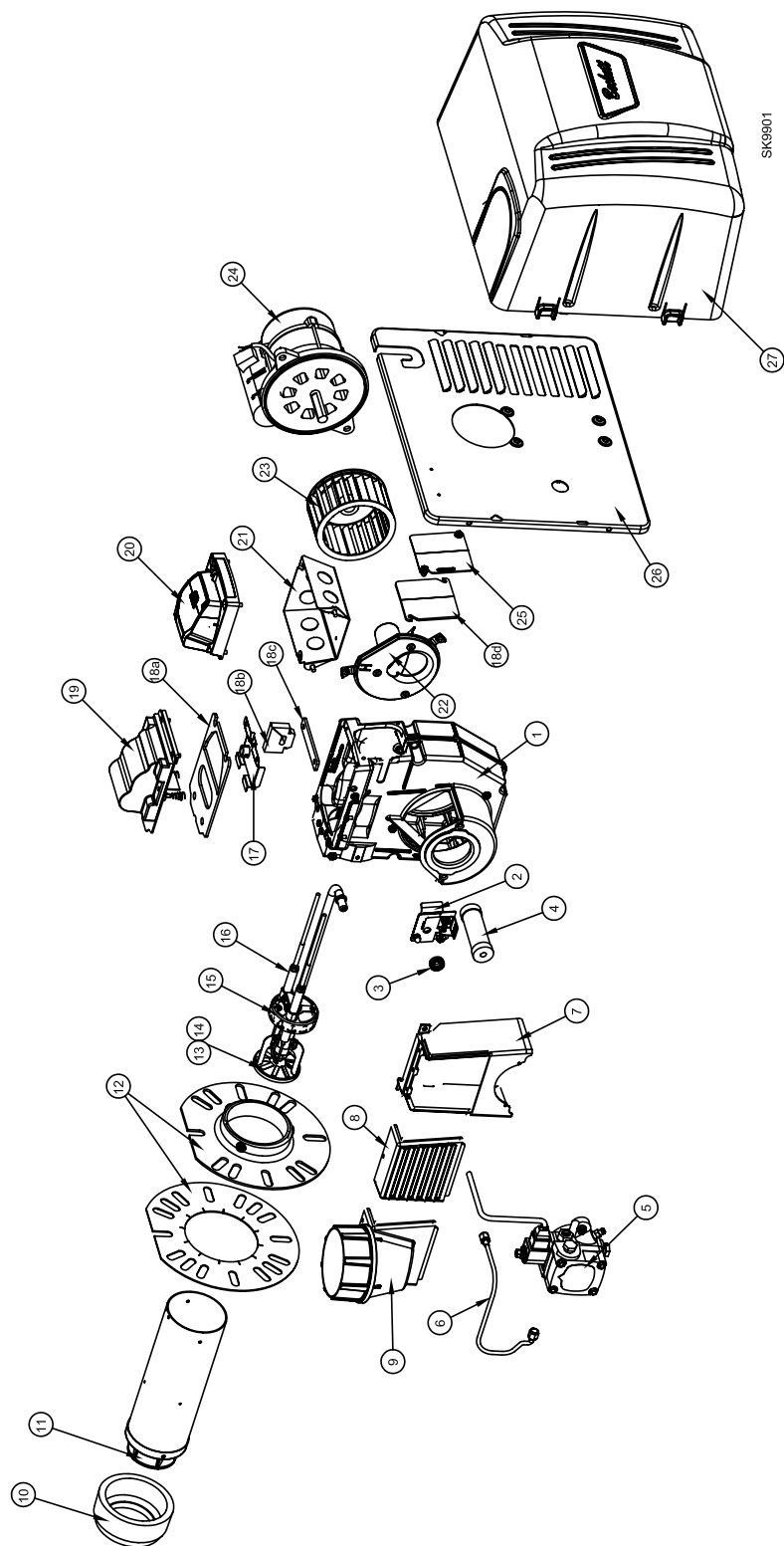

BURNER COMPONENTS

Drawing No.	Bard Part #	Supplier Part #	Description	FLF075V42A	FLR075V42A	FLF110V48A	FLR100V48A	FLF110V60A	FLR100V60A	FLR130V60A
1	N/A	51783GY	Housing	X	X	X	X	X	X	X
2	N/A	52000U	Head/Air Adjustment Mechanism Assy.	X	X	X	X	X	X	X
3	9022-018	3666	Splined Nut	X	X	X	X	X	X	X
4	9022-011	2454	Coupling	X	X	X	X	X	X	X
5	9022-082	21844U	"CleanCut" Oil Pump (Includes Mounting Screws)	X	X	X	X	X	X	X
6	N/A	51127	Connector Tube Assembly, 11"	X	X	X	X	X	X	X
7	N/A	1010U	Inlet Air Box	X	X	X	X	X	X	X
8	N/A	1013U	Inlet Air Louvers	X	X	X	X	X	X	X
9	N/A	1014U	Inlet Air Adaptor/Outside Air Kit	X	X	X	X	X	X	X
10	9022-096	32246	Heat Shield	X	X	X	X	X	X	X
11	N/A	N/A	Air Tube Combination	N/A	N/A	N/A	N/A	N/A	N/A	N/A
12	9022-097	NX84LBHS	Air Tube Combination Including Screws	X	X	X	X	X	X	X
13	N/A	N/A	Retention Head Assembly (6-Slot)	N/A	N/A	N/A	N/A	N/A	N/A	N/A
14	9022-098	51815U	Retention Head Assembly (9-Slot)	X	X	X	X	X	X	X
15	9022-099	NX84LB	Nozzle, Line Electrode, Head Assy., with Window	X	X			X	X	
15	9022-101	NX64LB	Nozzle, Line Electrode, Head Assy., with Window			X	X			X
16	9022-100	51811U	Electrode Insulator Kit	X	X	X	X	X	X	X
17	N/A	32058U	Spring, Igniter Prop	X	X	X	X	X	X	X
18	N/A	51942U	Gasket Igniter Kit: - Gasket, Igniter Baseplate - Gasket, Wiring Hinge - Gasket, Igniter Baseplate Hinge - Gasket, Rear Access Door	X	X	X	X	X	X	X
19	9022-079	51771U	Igniter, Electronic	X	X	X	X	X	X	X
20	9022-095	7505B1500	Genisys Ignition Logic Control	X	X	X	X	X	X	X
21	9022-058	5770	Electrical Box	X	X	X	X	X	X	X
22	N/A	101101U	Air Guide	X	X	X	X	X	X	X
23	9022-045	2999U	Blower Wheel	X	X	X	X	X	X	X
24	9022-084	21839	PSC Motor 1/7 H.P.	X	X	X	X	X	X	X
25	N/A	32119U	Door, Rear Access	X	X	X	X	X	X	X
26	N/A	N/A	Mounting Plate, Burner Cover	X	X	X	X	X	X	X
27	N/A	N/A	Cover, Burner	X	X	X	X	X	X	X
NS	N/A	51801U	Universal Adjust. Flange Kit, incl. 32086 Gasket	X	X	X	X	X	X	X
NS	9022-088	21807	Cordset Non-Delay 17"	X	X	X	X	X	X	X
NS	9022-085	7006U	CAD Cell Assembly	X	X	X	X	X	X	X
NS	9011-022	N/A	Nozzle 0.85X60° Solid					X	X	X
NS	9011-023	N/A	Nozzle 0.75X60° Solid			X	X			
NS	9011-025	N/A	Nozzle 0.50X60° Solid	X	X					