

REPLACEMENT PARTS MANUAL

OIL FIRED FURNACE

MODELS: FLR085D36C, FLR110D48C, FLR140D60C

Manual 2110-915

Revision C

Date 10-23-95

Supersedes 06-30-95

* GENERAL NOTES *

*Revised and/or additional pages may be issued from time to time.
*A complete and current manual consists of pages dated as shown in the following index.

** INDEX **

<u>Page Description</u>	<u>Page</u>	<u>Date</u>	<u>Supersedes</u>
Cabinet Components--Exploded View	1	7-15-93	
" " --Usage List	2	10-23-95	6-30-95
Functional Components--Exploded View	3	7-15-93	
" " --Usage List	4	12-15-93	7-15-93
Burner Components--Layout	5	7-15-93	
" " --Usage List	6	7-15-93	
Burner/Combustion Chamber Mounting System--Layout	7	7-15-93	
" " " " " --Usage	8	10-23-95	7-15-93

*** IMPORTANT ***

Contact the installing and/or local Bard distributor for all parts requirements. Make sure you have the complete model and serial number available from the unit rating plate.

BARD MANUFACTURING COMPANY

BRYAN, OHIO 43506

CABINET COMPONENTS

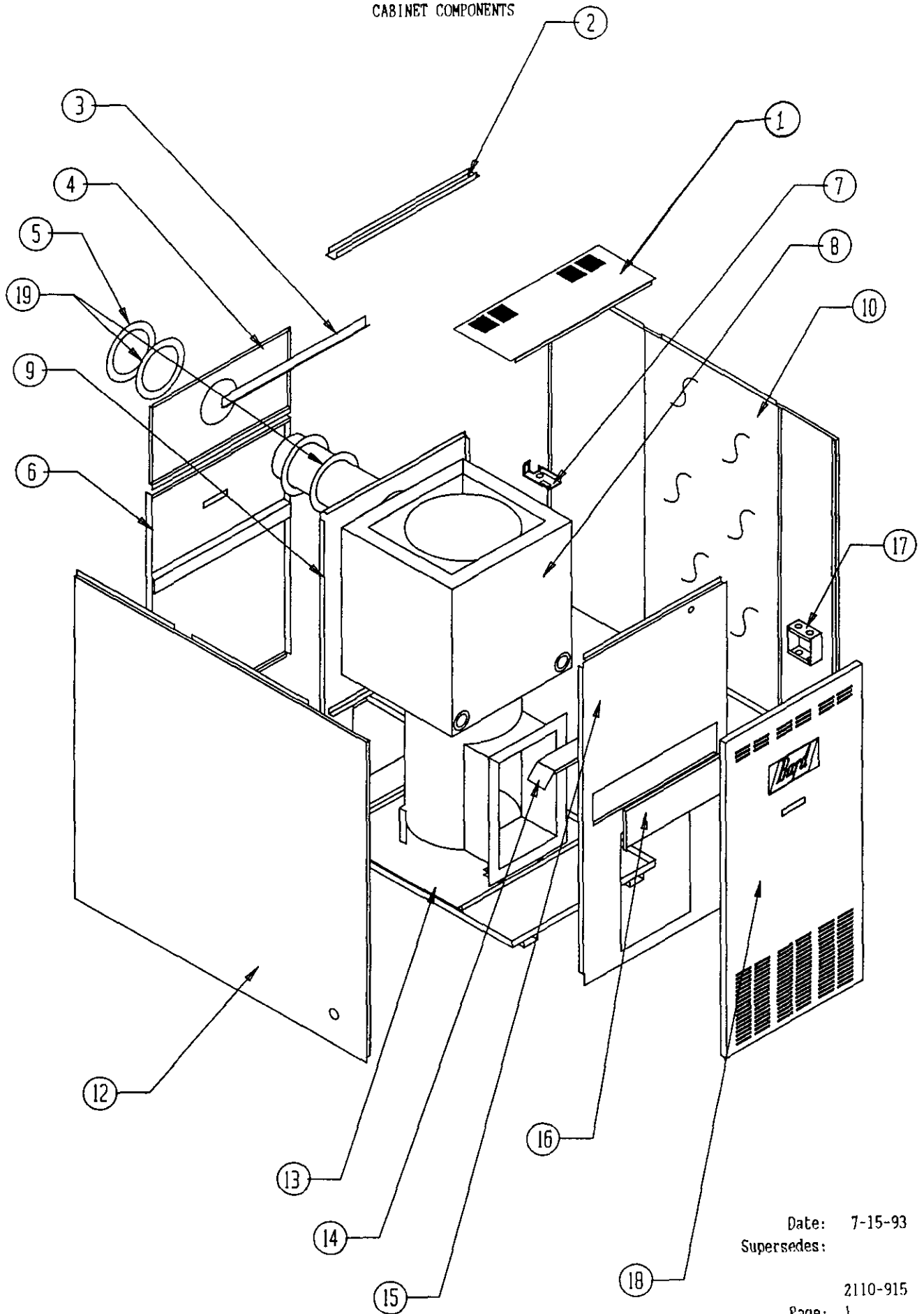

Date: 7-15-93
Supersedes:
2110-915
Page: 1

CABINET COMPONENTS

Dwg. No.	Part No.	Description	FLR085D36C	FLR110D48C	FLR140D60C
1	106-126	Top Fill	X	X	
1	106-128	Top Fill			X
2	164-536	Top Channel	X	X	
2	164-537	Top Channel			X
3	540-189	Filter Support	X	X	
3	540-175	Filter Support			X
4	108-082	Upper Back	X		
4	108-083	Upper Back		X	
4	108-085	Upper Back			X
5	S166-019	Smoke Pipe Clamp Ring Assembly	2	2	2
6	S552-219	Blower Door	X	X	
6	S552-197	Blower Door			X
7	112-173	Door Switch Bracket	X	X	X
8	S171-212	Heat Exchanger Assembly	X		
8	S171-214	Heat Exchanger Assembly		X	
8	S171-215	Heat Exchanger Assembly			
9	521-208	Blower Partition	X		
9	521-210	Blower Partition		X	
9	521-171	Blower Partition			X
10	S501-246	Right Side	X		
10	S501-248	Right Side		X	
10	S501-222	Right Side			X
12	S501-247	Left Side (Furnace serial number required)	X		
12	S501-249	Left Side (Furnace serial number required)		X	
12	S501-223	Left Side (Furnace serial number required)			X
13	127-175	Base	X	X	
13	127-180	Base			X
14	168-048	Air Baffle	X		X
14	168-076	Air Baffle		X	
15	S520-219	Burner Partition	X		
15	S520-218	Burner Partition		X	
15	S520-197	Burner Partition			X
16	542-037	Clean Out Cover Plate	X	X	
16	542-038	Clean Out Cover Plate			X
17	116-157	Junction Box	X	X	X
18	S152-184	Burner Door	X		
18	S152-185	Burner Door		X	
18	S152-198	Burner Door			X
19	1921-037	Smoke Pipe Gasket 6"	2	2	2

Date: 10-23-95
Supersedes: 6-30-95

FUNCTIONAL COMPONENTS

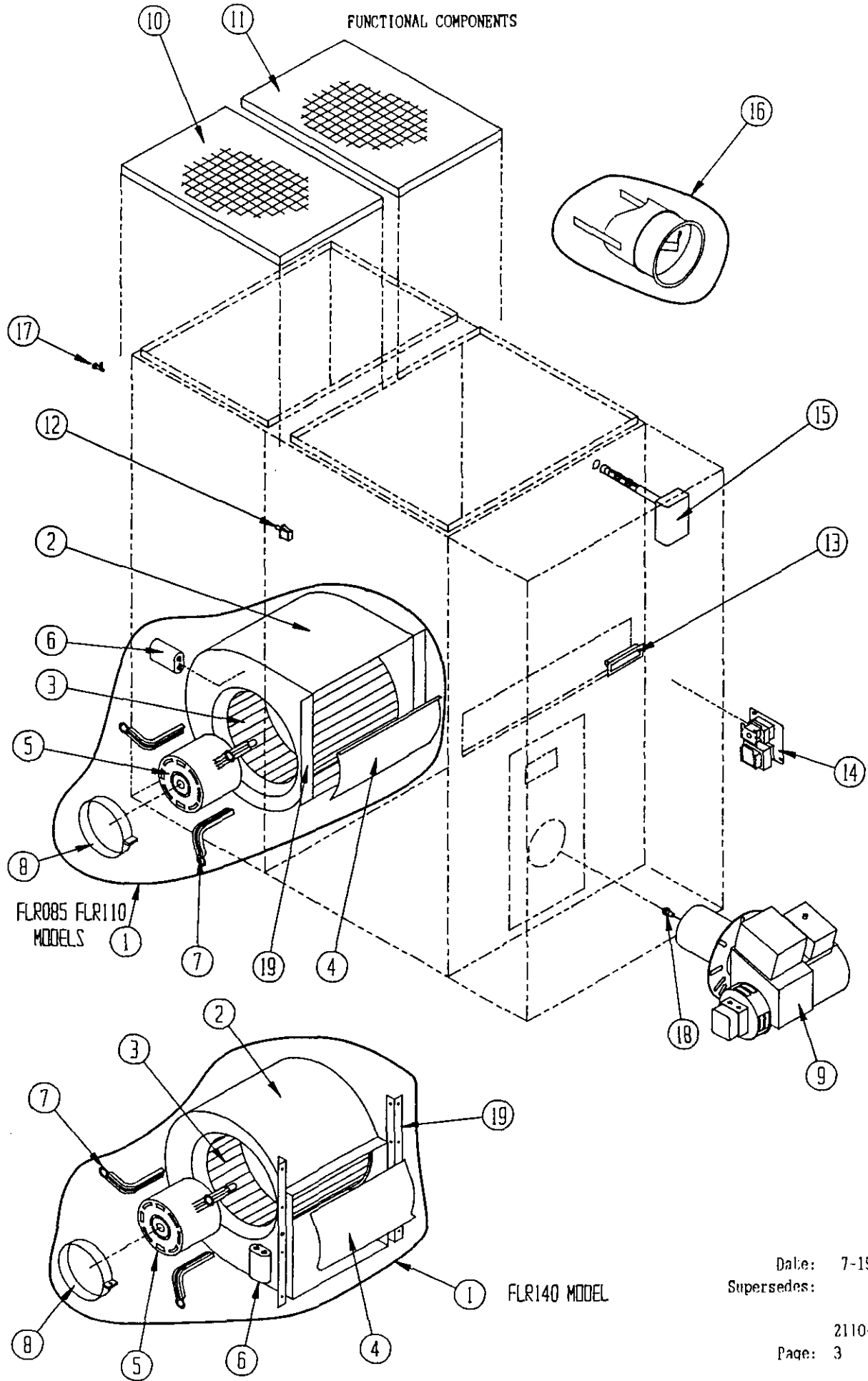

FLR085 FLR110
MODELS

FLR140 MODEL

Date: 7-15-93
Supersedes:

2110-915
Page: 3

FUNCTIONAL COMPONENTS

Dwg. No.	Part No.	Description	FLR085D36C	FLR110D48C	FLR140D60C
1	900-199	Blower Assembly			X
1	900-197	Blower Assembly	X		
1	900-198	Blower Assembly		X	
2	151-073	Blower Housing Assembly	X		
2	151-082	Blower Housing Assembly		X	
2	5152-050	Blower Housing Assembly (1)			X
3	5152-014	Blower Wheel	X		
3	5152-053	Blower Wheel			X
3	5152-059	Blower Wheel		X	
4	144-128	Diffuser	X		
4	144-129	Diffuser		X	
4	NA	Diffuser (1)			X
5	8105-040	Motor 1/3 hp ccw	X		
5	8106-033	Motor 1/2 hp cw		X	
5	8107-007	Motor 3/4 hp 115C ccw PSC			X
6	8552-002	Capacitor 5/370	X		
6	8552-004	Capacitor 7.5/370		X	
6	8552-026	Capacitor 15/370			X
7	8200-034	Motor Mount Arm	3	3	
7	8200-035	Motor Mount Arm			3
8	8200-033	Motor Mount Band	X	X	X
9	901-0108	Oil Burner (Includes nozzle part No. 9011-001)	X		
9	901-0109	Oil Burner (Includes nozzle part No. 9011-003)		X	
9	901-0110	Oil Burner (Includes nozzle part No. 9011-006)			X
10	7003-020	Permanent Filter 11.5 x 17 x 1	1		
10	7003-021	Permanent Filter 10 x 20 x 1		1	
10		Not used on 140 model			
11	7003-016	Permanent Filter 13 x 20 x 1		1	2
11	7003-020	Permanent Filter 11.5 x 17 x 1	1		
12	8406-047	Door Switch	X	X	X
13	1171-025	Door Pull	2	2	2
14	8201-006	Fan Center (2 speed relay)	X	X	X
15	8620-080	Fan/Limit Control	X	X	X
16	8601-031	Barometric Damper	X	X	X
17	1171-012	Flush Cabinet Latch	X	X	X
18	9011-001	Nozzle .75 GPH 80 Degree	X		
18	9011-003	Nozzle 1.00 GPH 80 Degree		X	
18	9011-006	Nozzle 1.25 GPH 80 Degree			X
19	104-783	Blower Angles	2	2	
19	104-794	Blower Angles			2
	4047-114	Wire Diagram	X	X	X

(1) Balloon No. 2 part No. 5152-050 includes housing, diffuser, and blower wheel part No. 5152-053.

Date: 12-15-93
Supersedes: 7-15-93

Burner Replacement Parts

Oil Burners

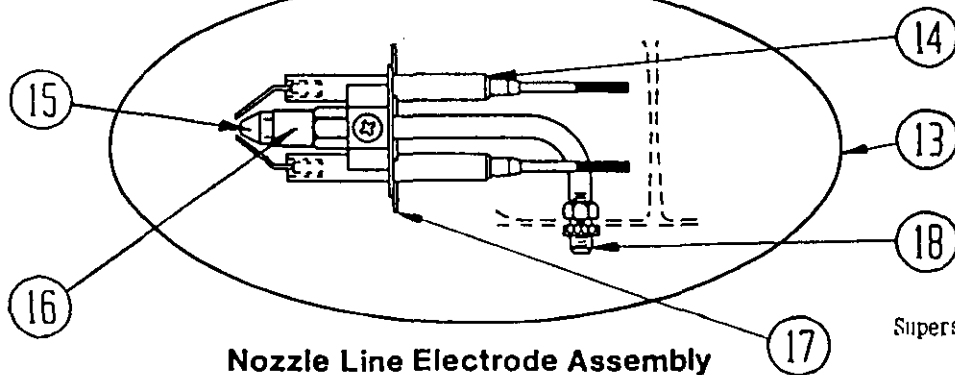
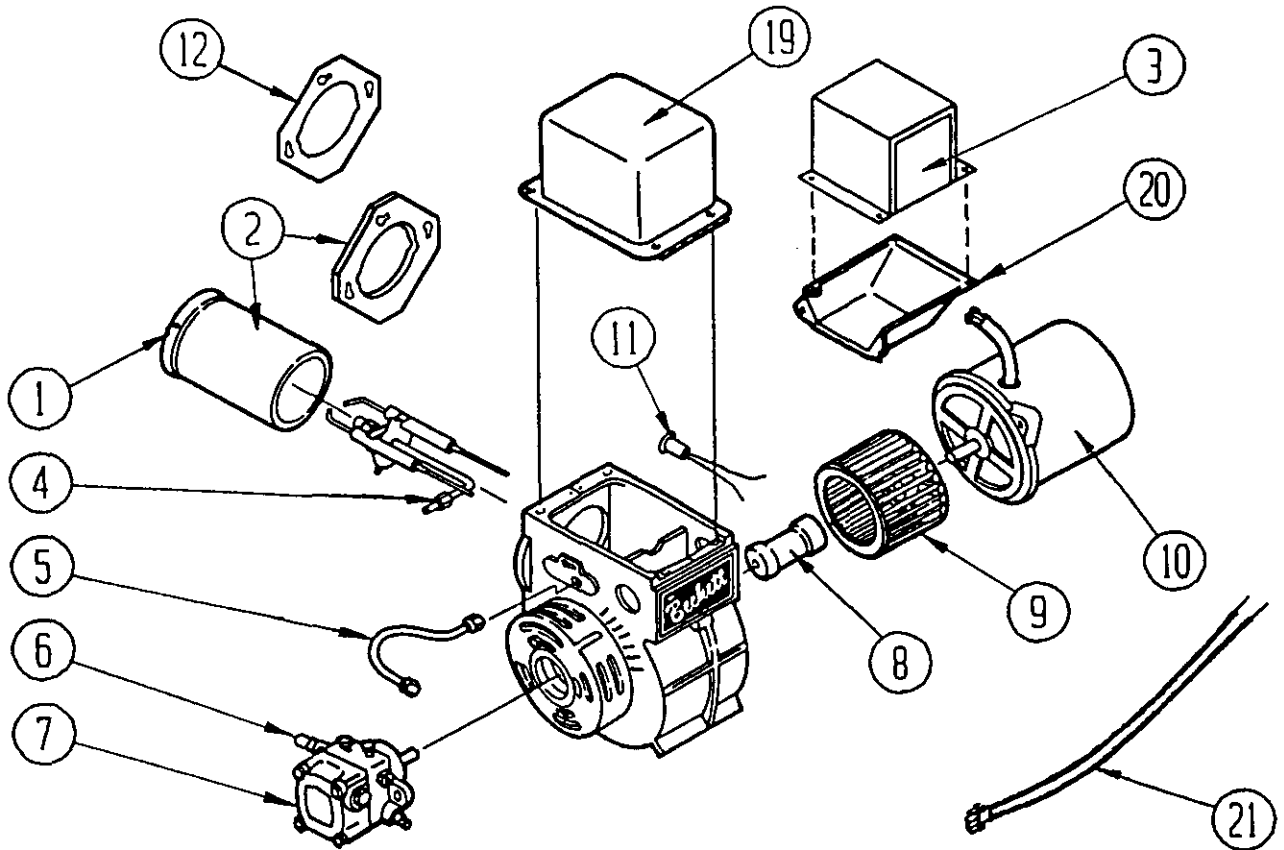

Nozzle Line Electrode Assembly

*Nozzle is not included in assembly.

Date: 7-15-93
Supersedes:

2110-915

Page: 5

BURNER COMPONENTS

Dwg. No.	Bard Part No.	Supplier Part No.	Description	FLR085D36C	FLR110D48C	FLR140D60C
1	9022-003	F3	Head	X	X	
1	9022-034	F4	Head			X
2	9022-019	51236009BK	Air Tube and Flange Assy. 5-1/2" Insertion	X	X	X
3	9022-056	7022U	Primary Control	X	X	X
4	9022-007	571801	Bulkhead Fitting	X	X	X
5	9022-008	5636	Connector Tube	X	X	X
6	9022-009	2256	Pump Outlet Elbow	X	X	X
7	9022-010	2460U	Pump, Single Stage	X	X	X
8	9022-011	2454	Coupling	X	X	X
9	9022-012	2459U	Blower	X	X	X
10	9022-013	2456U	Motor 1/7 HP 3450 RPM	X	X	X
11	9022-054	7006U	Cad Cell	X	X	X
12	9022-024	3616	Mounting Flange Gasket	X	X	X
13	9022-015	NL72YH	Nozzle Line Electrode Assembly	X	X	X
14	9022-017	5780	Electrode Insulator Assembly	X	X	X
15	9011-001		Nozzle .75 GPH 80 degree A	X		
15	9011-003		Nozzle 1.00 GPH 80 degree A		X	
15	9011-006		Nozzle 1.25 GPH 80 degree A			X
16	9022-016	213U	Nozzle Adapter, Single	X	X	X
17	9022-023	3384P	Static Plate 3-3/8"	X	X	
17	9022-035	3383P	Static Plate 2-3/4"			X
18	9022-018	3666	Bulkhead Fitting Locknut	X	X	X
19	9022-057	2442U	Ignition Transformer	X	X	X
20	9022-058	5770	Electrical Box Kit	X	X	X
21	9022-055	31838	Power Cord	X	X	X

Date: 7-15-93
Supersedes:

BURNER/COMBUSTION CHAMBER MOUNTING SYSTEM

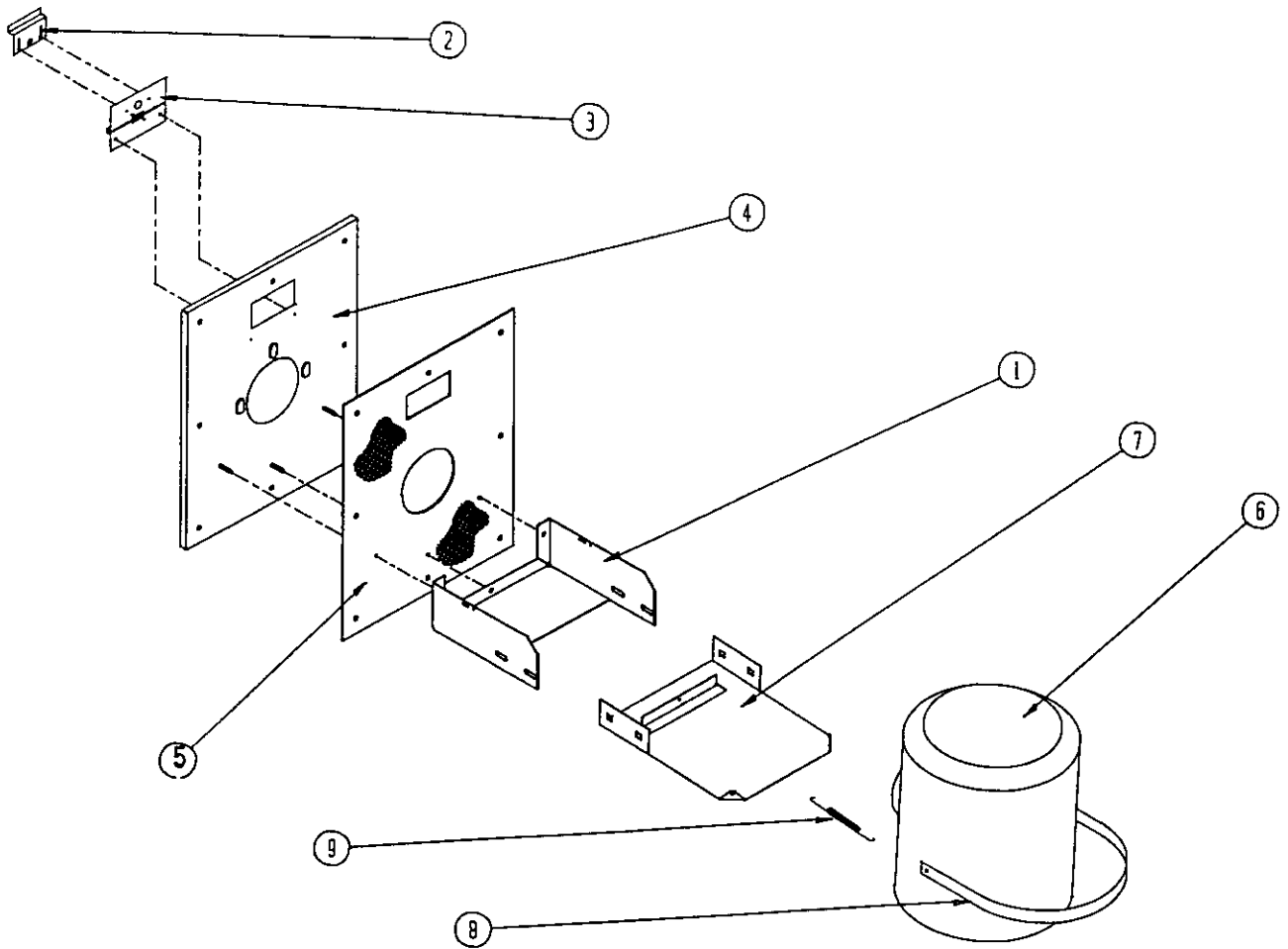

Date: 7-15-93
Supersedes:

BURNER/COMBUSTION CHAMBER MOUNTING SYSTEM

Dwg. No.	Bard Part No.	Description	FLR085D36C	FLR110D48C	FLR140D60C
1	112-170	Combustion Chamber Bracket	X	X	
1	112-168	Combustion Chamber Bracket			X
2	142-026	Inspection Door Cover Plate	X	X	X
3	142-027	Inspection Door Hinge	X	X	X
4	161-033	Front Plate Assembly	X	X	
4	161-034	Front Plate Assembly			X
5	1921-026	Front Plate Gasket	X	X	
5	1921-027	Front Plate Gasket			X
6	7090-005	Combustion Chamber	X	X	
6	7090-003	Combustion Chamber			X
7	S112-160	Bracket Extension	X	X	
7	S112-167	Bracket Extension			X
8	140-198	Combustion Chamber Support	X	X	
8	140-199	Combustion Chamber Support			X
9	5401-004	Stainless Steel Spring	X	X	X
-	S173-077	Complete Assembly of All Parts	X	X	
-	S173-079	Complete Assembly of All Parts			X

Date: 10-23-95
Supersedes: 7-15-93

