

REPLACEMENT PARTS MANUAL

OIL FIRED FURNACE MODELS FH085D36B, FH110D48B, FH110D60B

Manual 2110-901

Revision E

Date 12-03-91

Supersedes 9-20-91

* GENERAL NOTES *

*Revised and/or additional pages may be issued from time to time.
*A complete and current manual consists of pages dated as shown in the following index.

** INDEX **

<u>Page Description</u>	<u>Page</u>	<u>Date</u>	<u>Supersedes</u>
Cabinet Components--Exploded View	1	9-20-91	9-18-89
" " --Usage List	2	9-20-91	1-03-91
Functional Components--Exploded View	3	9-20-91	9-18-89
" " --Usage List	4	9-20-91	1-03-91
Burner Components--Layout	5	12-03-91	9-18-89
" " --Usage List	6	12-03-91	5-18-90

*** IMPORTANT ***

Contact the installing and/or local Bard distributor for all parts requirements. Make sure you have the complete model and serial number available from the unit rating plate.

CABINET COMPONENTS

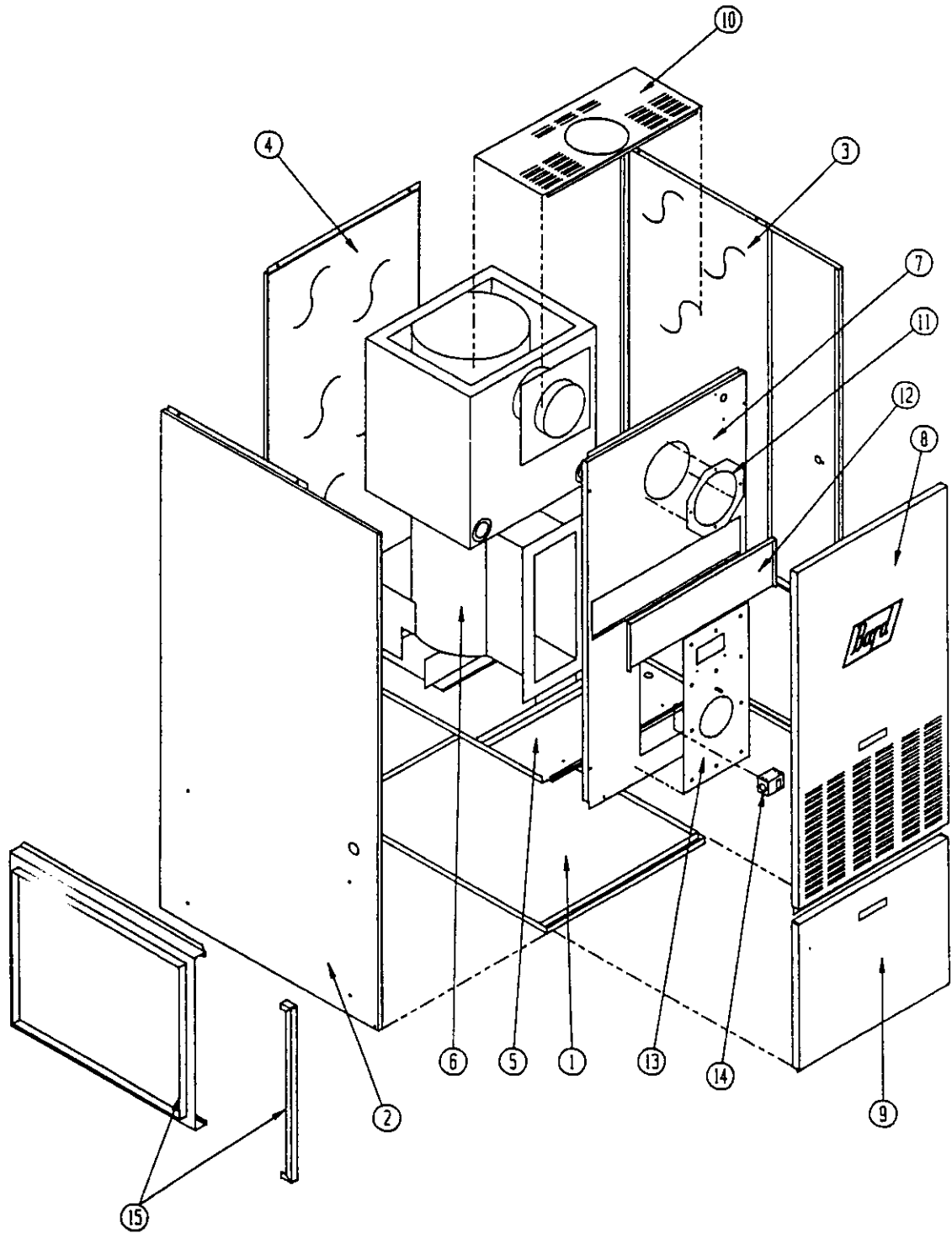

Date: 9-20-91
Supersedes: 9-18-89

CABINET COMPONENTS

Dwg. No.	Part No.	Description	F H O 8 5 D 3 6 B	F H I 1 O D 4 8 B	F H I 1 O D 6 O B
1	127-174	Lower Base	X	X	X
2	501-239	Left Side		X	X
2	501-237	Left Side	X		
3	501-238	Right Side		X	X
3	501-236	Right Side	X		
4	508-077	Back Assembly	X		
4	508-076	Back Assembly		X	X
5	127-173	Blower Base	X		
5	127-170	Blower Base		X	X
6	171-166	Heat Exchanger Assembly (includes combustion chamber part No. 7090-005) (1)	X		
6	171-165	Heat Exchanger Assembly (includes combustion chamber part No. 7090-005) (1)		X	X
7	520-193	Burner Partition	X		
7	520-192	Burner Partition		X	X
8	152-180	Burner Door	X		
8	152-176	Burner Door		X	X
9	152-155	Blower Door	X	X	X
10	106-052	Top Fill	X	X	X
11	166-007	Smoke Pipe Collar	X	X	X
12	542-037	Cleanout Cover Plates	X	X	X
13	161-027	Front Plate Assembly	X	X	X
14	112-031	Door Switch Bracket	X	X	X
15	919-0002	Filter Rack W/Door	X	X	
15	919-0003	Filter Rack W/Door			X

(1) Combustion chamber part No. 7090-005 may be ordered separately.

Date: 9-20-91
Supersedes: 1-03-91

FUNCTIONAL COMPONENTS

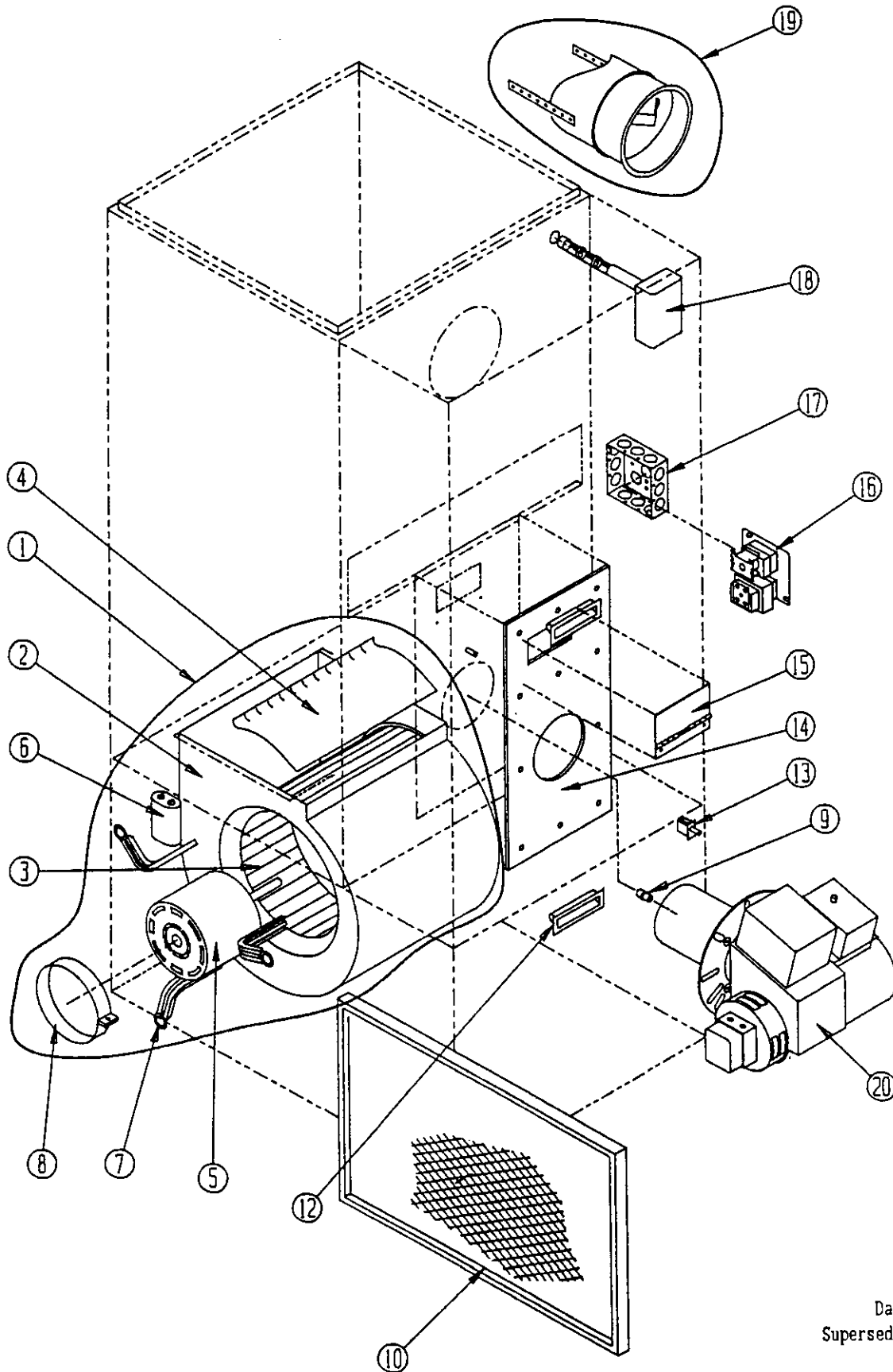

Date: 9-20-91
Supersedes: 9-18-89

FUNCTIONAL COMPONENTS

Dwg. No.	Part No.	Description	F H O 8 5 D 3 6 B	F H 1 1 0 D 4 8 B	F H 1 1 0 D 6 0 B
1	900-156	Blower Assembly	x		
1	900-111	Blower Assembly		x	
1	900-166	Blower Assembly			x
2	144-115	Blower Housing Assembly	x		
2	144-116	Blower Housing Assembly		x	
2	5152-010	Blower Housing Assembly (1)			x
3	5152-013	Blower Wheel	x		
3	5152-053	Blower Wheel			x
3	5152-059	Blower Wheel		x	
4	144-127	Diffuser	x		
4	144-129	Diffuser		x	
4	NA	Diffuser (1)			x
5	8105-008	Motor 1/3 HP	x		
5	8106-018	Motor 1/2 HP		x	
5	8107-004	Motor 3/4 HP			x
6	8552-002	Capacitor 5/370 MFD	x		
6	8552-004	Capacitor 7-1/2 /370 MFD		x	
6	8552-026	Capacitor 15/370 MFD			x
7	8200-034	Motor Mount Arm	3	3	
7	8200-035	Motor Mount Arm			3
8	8200-033	Motor Mount Band	x	x	x
9	9011-001	Nozzle .75 GPH 80 degree	x		
9	9011-003	Nozzle 1.00 GPH 80 degree		x	x
10	7003-004	Permanent Filter 16x25x1	x	x	
10	7003-028	Permanent Filter 20x25x1			x
12	1171-025	Door Pull	2	2	2
13	8406-013	Door Switch	x	x	x
14	1921-021	Front Plate Gasket	x	x	x
15	5400-003	Inspection Door Hinge	x	x	x
16	8201-006	Fan Center--Two Speed	x	x	x
17	8614-001	Square Outlet Box	x	x	x
18	8402-043	Fan/Limit Control	x	x	x
19	8601-031	Barometric Damper	x	x	x
20	9020-017	Burner Assembly	x	x	x

(1) Drawing No. 2 part No. 5152-050 includes housing, diffuser, and blower wheel part No. 5152-053.

Date: 9-20-91
Supersedes: 1-03-91

2110-901

Burner Replacement Parts

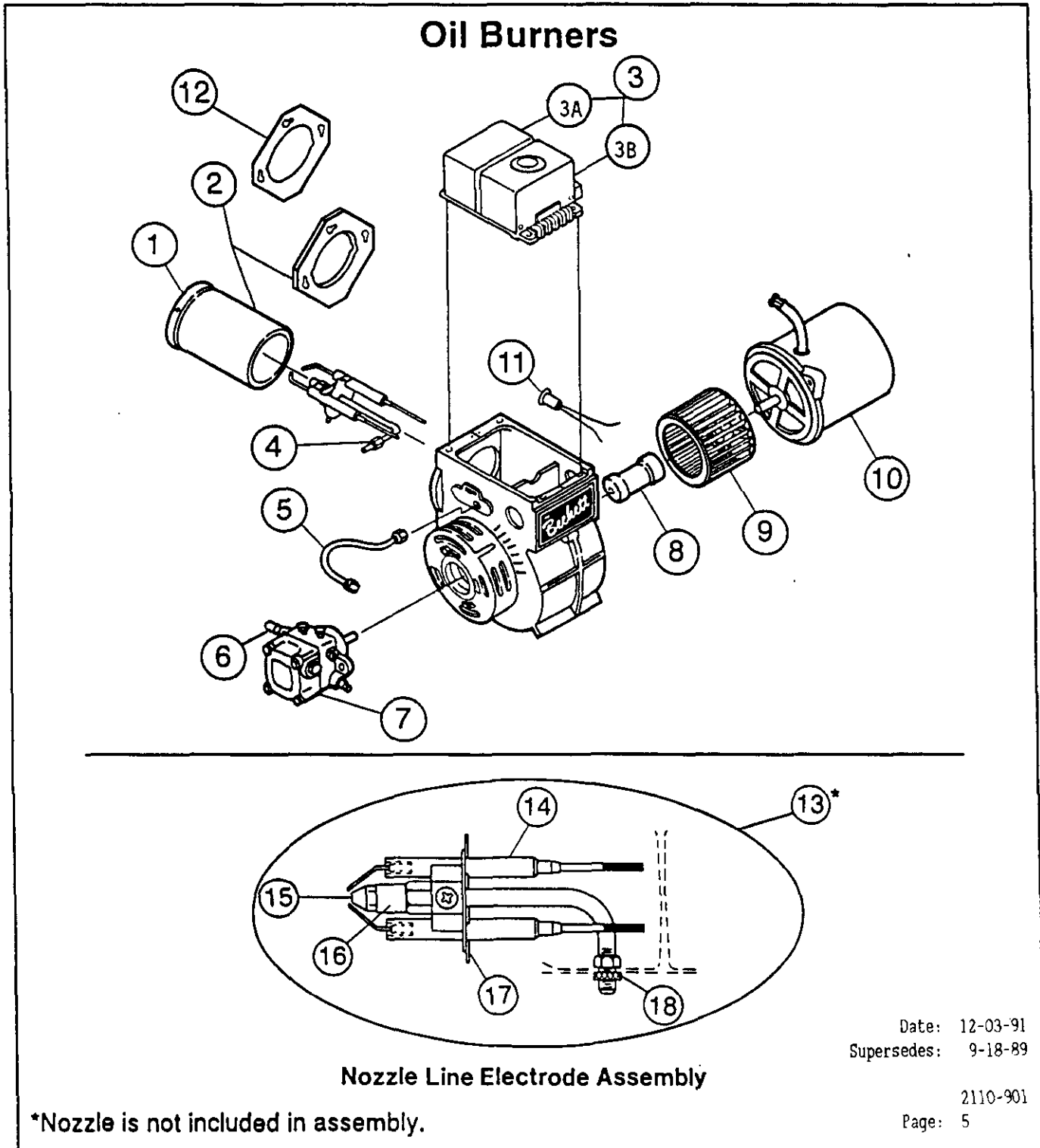

BURNER COMPONENTS

Dwg. No.	Bard Part No.	Supplier Part No.	Description	F H O 8 5 D 3 6 B	F H I O D 4 8 B
1	9022-003	F3	Head	X	X
2	9022-004	51236007BK 51560	Air Tube and Flange Assembly 7-5/8" Insertion	X	X
3	9022-036	40100-02-BK	Primary Control and Ignitor Assembly*	X	X
3A	9022-037	14280-SO-S	Interrupted Duty Ignitor Only	X	X
3B	9022-038	14290-02-AOS	Primary Control Only	X	X
4	9022-007	571801	Bulkhead Fitting	X	X
5	9022-008	5636	Connector Tube	X	X
6	9022-009	2256	Pump Outlet Elbow	X	X
7	9022-010	2460U	Pump, Single Stage	X	X
8	9022-011	2454	Coupling	X	X
9	9022-012	2459U	Blower	X	X
10	9022-013	2456U	Motor 1/7 HP 3450 RPM	X	X
11	9022-039	40153-SO-B	Cad Cell Assembly**	X	X
	9022-040	14407S	Cad Cell Eye Only	X	X
12	9022-021	3811	Mounting Flange Gasket	X	X
13	9022-014	NL90YH	Nozzle Line Electrode Assembly	X	X
14	9022-017	5780	Electrode Insulator Assembly	X	X
15	9011-001		Nozzle .75 GPH 80 degree A	X	
15	9011-003		Nozzle 1.00 GPH 80 degree A		X
16	9022-016	213U	Nozzle Adapter, Single	X	X
17	9022-023	3384P	Static Plate 3-3/8"	X	X
18	9022-018	3666	Bulkhead Fitting Locknut	X	X

* Includes 9022-037 interrupted duty ignitor, 9022-038 primary control, and 9022-039 cad cell assembly.

** Includes 9022-040 cad cell eye.

Date: 12-03-91
Supersedes: 5-18-90

