REPLACEMENT PARTS MANUAL

WALL MOUNTED GAS/ELECTRIC

Models:

W42G4-A W48G4-A W60G4-A W42G4DA W48G4DA W60G4DA
W42G4-B W48G4-B W60G4-B W42G4DB W48G4DB W60G4DB
W42G4-C W48G4-C W60G4-C W42G4DC W48G4DC W60G4DC

Contents

<i>Description</i>	<i>Page</i>
Cabinet Components	
♦ Exploded View	2
♦ Usage List	3
♦ Usage List	4
♦ Usage List	5
Functional Components	
♦ Exploded View	6
♦ Usage List	7
♦ Usage List	8
Burner Components	
♦ Exploded View	10
♦ Usage List	11
♦ Usage List	12
♦ Usage List	13
Control Panel	
♦ Exploded View	14
♦ Usage List	15
♦ Usage List	16
Blower Assembly	
♦ Exploded View	17
♦ Usage List	17

General Notes

- Revised and/or additional pages may be issued from time to time.
- A complete and current manual consists of pages shown in the following contents section.

Important

- Contact the installing and/or local Bard distributor for all parts requirements. Make sure to have the complete model and serial number available from the unit rating plates.



Climate Control Solutions

Bard Manufacturing Company, Inc.
Bryan, Ohio 43506
www.bardhvac.com

Manual: 2110-822
Supersedes: **NEW**
Date: 12-12-19

CABINET COMPONENTS - STANDARD & DEHUMIDIFICATION

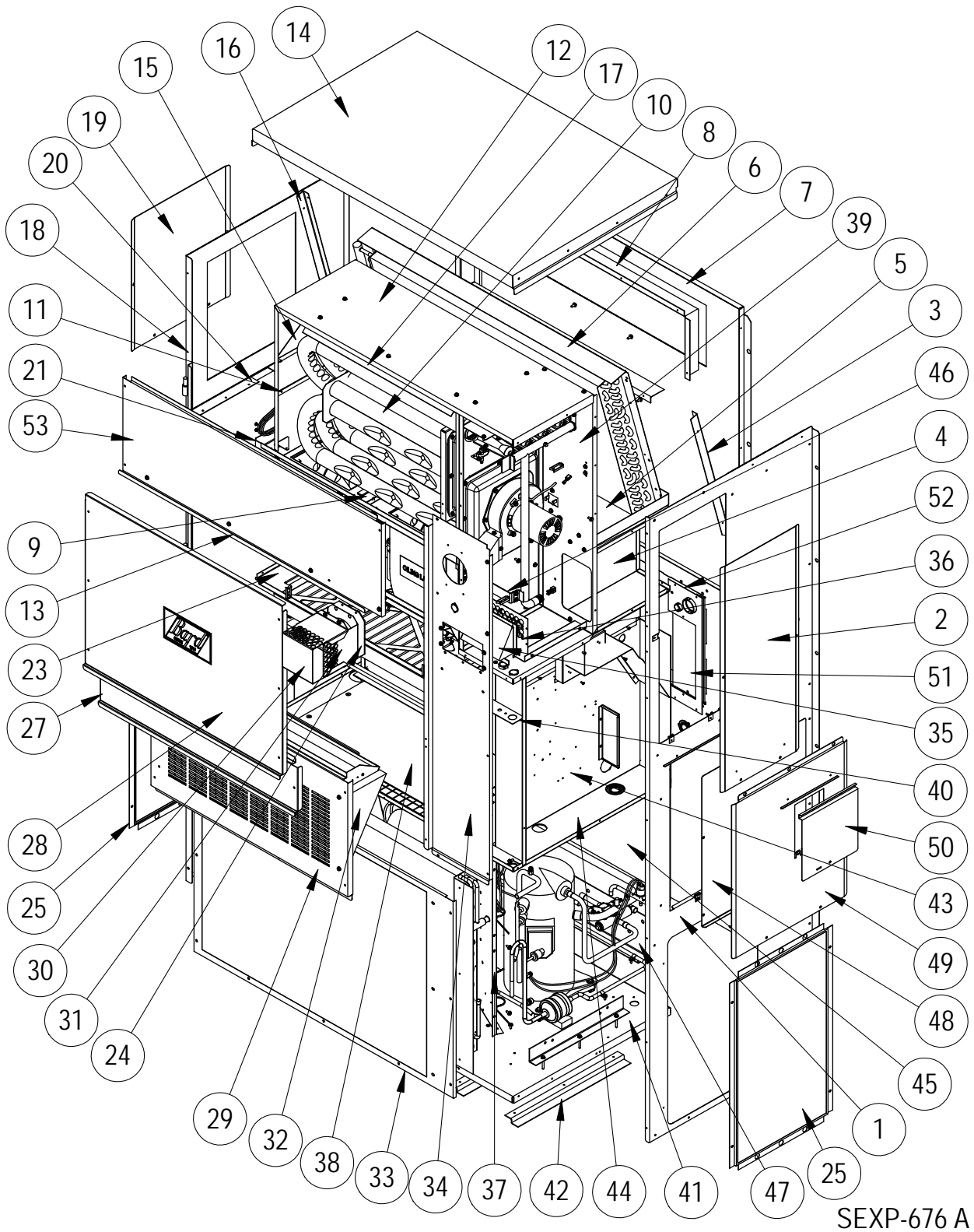

This drawing to be used for reference for pages 3, 4 and 5

CABINET COMPONENTS – STANDARD & DEHUMIDIFICATION

Drawing No.	Part No.	Description	All Models
1	501-570-*	Right Side Assembly	X
2	S153-326-*	Vestibule Service Door	X
3	105X1073	Right Evaporator Support Angle	X
4	541-266	Right Drain Pan Support Assembly	X
5	S523-123	Drain Pan Assembly	X
6	105-1080	Evaporator Coil Fill Angle	X
7	509-156	Upper Back	X
8	111-063	Supply Air Frame	2
9	103-439	Heat Exchanger Support Offset	X
10	Heat Exch Assy	See Burner Components Diagram	
11	105-1066	Lower Heat Exchanger Deflector	X
12	135-216	Inner Air Baffle	X
13	165-586-*	Top Rain Channel	X
14	507-246-*	Top Assembly	X
15	135-184	Right Heat Exchanger Deflector	X
16	105Y1073	Left Evaporator Support Angle	X
17	105-1076	Top Heat Exchanger Deflector	X
18	501-788-*	Left Side Assembly	X
19	543-070-*	Left Access Cover	X
20	105-1070	Left Support Angle	X
21	S121-484	Blower Partition	X
23	131-163	Filter Tray	X
24	1921-051	Vent Terminal Gasket	X
25	118-084-*	Side Grille	2
<i>Continued on page 4 for standard units and on page 5 for dehumidification units</i>			

* Exterior cabinet parts are manufactured with various paint color options. To ensure the proper paint color is received, include the complete model number and serial number of the unit for which parts are being ordered.

CABINET COMPONENTS – STANDARD

Drawing No.	Part No.	Description	W42G4-A	W42G4-B	W42G4-C	W48G4-A	W48G4-B	W48G4-C	W60G4-A	W60G4-B	W60G4-C
<i>Continued from page 3</i>											
27	553-562-*	Filter Access Panel Assembly	X	X	X	X	X	X	X	X	X
28	S553-561-*	Front Door Assembly	X	X	X	X	X	X	X	X	X
29	553-327-*	Vent Option Door Assembly	X	X	X	X	X	X	X	X	X
30	169-119	Outer Vent Hood	X	X	X	X	X	X	X	X	X
31	169-120	Inner Vent Hood	X	X	X	X	X	X	X	X	X
32	WGBFAD-5	Barometric Fresh Air Damper	X	X	X	X	X	X	X	X	X
33	118-048-*	Condenser Grille	X	X	X	X	X	X	X	X	X
34	549-131-*	Right Front Corner Assembly	X	X	X	X	X	X	X	X	X
35	S135-181-*	Air Intake Hood	X	X	X	X	X	X	X	X	X
36	S134-182-*	Air Intake Back	X	X	X	X	X	X	X	X	X
37	125-024	Fan Shroud	X	X	X	X	X	X	X	X	X
38	542-072	Condenser Partition Blank Off Plate	X	X	X	X	X	X	X	X	X
39	541-398	Heat Exchanger Support Assembly	X	X	X	X	X	X	X	X	X
40	142-071	Filter Blank Off Plate	X	X	X	X	X	X	X	X	X
41	127-561	Lower Base	X	X	X	X	X	X	X	X	X
42	103-438	Lower Base Offset	3	3	3	3	3	3	3	3	3
43	517-408	Control Panel Assembly	X	X	X	X	X	X	X	X	X
44	521-420	Condenser Partition Assembly	X	X	X	X	X	X	X	X	X
45	509-157	Lower Back Assembly	X	X	X	X	X	X	X	X	X
46	113-268	Manifold Bracket	X	X	X	X	X	X	X	X	X
47	113-140	Bottom Support Bracket	X	X	X	X	X	X	X	X	X
48	S133-163	Circuit Breaker Inner Door	X	X		X	X		X	X	
48	S133-318	Toggle Disconnect Inner Door			X			X			X
49	S533-162-*	Control Panel Cover Assembly	X	X	X	X	X	X	X	X	X
50	S153-328-*	Disconnect Access Door	X	X	X	X	X	X	X	X	X
51	134-193	Conduit Access Panel	X	X	X	X	X	X	X	X	X
52	156-029	Conduit Entrance Plate	X	X	X	X	X	X	X	X	X
53	553-388-*	Upper Door Assembly	X	X	X	X	X	X	X	X	X
NS	5252-033	Bard Nameplate	X	X	X	X	X	X	X	X	X

* Exterior cabinet parts are manufactured with various paint color options. To ensure the proper paint color is received, include the complete model number and serial number of the unit for which parts are being ordered.

NS – Not Shown

Refer to drawing on page 2

CABINET COMPONENTS – DEHUMIDIFICATION

Drawing No.	Part No.	Description	W42G4DA	W42G4DB	W42G4DC	W48G4DA	W48G4DB	W48G4DC	W60G4DA	W60G4DB	W60G4DC
<i>Continued from page 3</i>											
27	553-562-*	Filter Access Panel Assembly	X	X	X	X	X	X	X	X	X
28	S553-561-*	Front Door Assembly	X	X	X	X	X	X	X	X	X
29	553-327-*	Vent Option Door Assembly	X	X	X	X	X	X	X	X	X
30	169-119	Outer Vent Hood	X	X	X	X	X	X	X	X	X
31	169-120	Inner Vent Hood	X	X	X	X	X	X	X	X	X
32	WGBFAD-5	Barometric Fresh Air Damper	X	X	X	X	X	X	X	X	X
33	118-048-*	Condenser Grille	X	X	X	X	X	X	X	X	X
34	549-131-*	Right Front Corner Assembly	X	X	X	X	X	X	X	X	X
35	S135-181-*	Air Intake Hood	X	X	X	X	X	X	X	X	X
36	S134-182-*	Air Intake Back	X	X	X	X	X	X	X	X	X
37	125-024	Fan Shroud	X	X	X	X	X	X	X	X	X
38	542-136	Condenser Partition Blank Off Plate	X	X	X	X	X	X	X	X	X
39	541-398	Heat Exchanger Support Assembly	X	X	X	X	X	X	X	X	X
40	142-071	Filter Blank Off Plate	X	X	X	X	X	X	X	X	X
41	127-561	Lower Base	X	X	X	X	X	X	X	X	X
42	103-438	Lower Base Offset	3	3	3	3	3	3	3	3	3
43	517-408	Control Panel Assembly	X	X	X	X	X	X	X	X	X
44	521-447	Condenser Partition Assembly	X	X	X	X	X	X	X	X	X
45	509-157	Lower Back Assembly	X	X	X	X	X	X	X	X	X
46	113-268	Manifold Bracket	X	X	X	X	X	X	X	X	X
47	113-140	Bottom Support Bracket	X	X	X	X	X	X	X	X	X
48	S133-163	Circuit Breaker Inner Door	X	X		X	X		X	X	
48	S133-318	Toggle Disconnect Inner Door			X			X			X
49	S533-162-*	Control Panel Cover Assembly	X	X	X	X	X	X	X	X	X
50	S153-328-*	Disconnect Access Door	X	X	X	X	X	X	X	X	X
51	134-193	Conduit Access Panel	X	X	X	X	X	X	X	X	X
52	156-029	Conduit Entrance Plate	X	X	X	X	X	X	X	X	X
53	553-388-*	Upper Door Assembly	X	X	X	X	X	X	X	X	X
NS	5252-033	Bard Nameplate	X	X	X	X	X	X	X	X	X

* Exterior cabinet parts are manufactured with various paint color options. To ensure the proper paint color is received, include the complete model number and serial number of the unit for which parts are being ordered.

NS – Not Shown

Refer to drawing on page 2

FUNCTIONAL COMPONENTS – STANDARD & DEHUMIDIFICATION

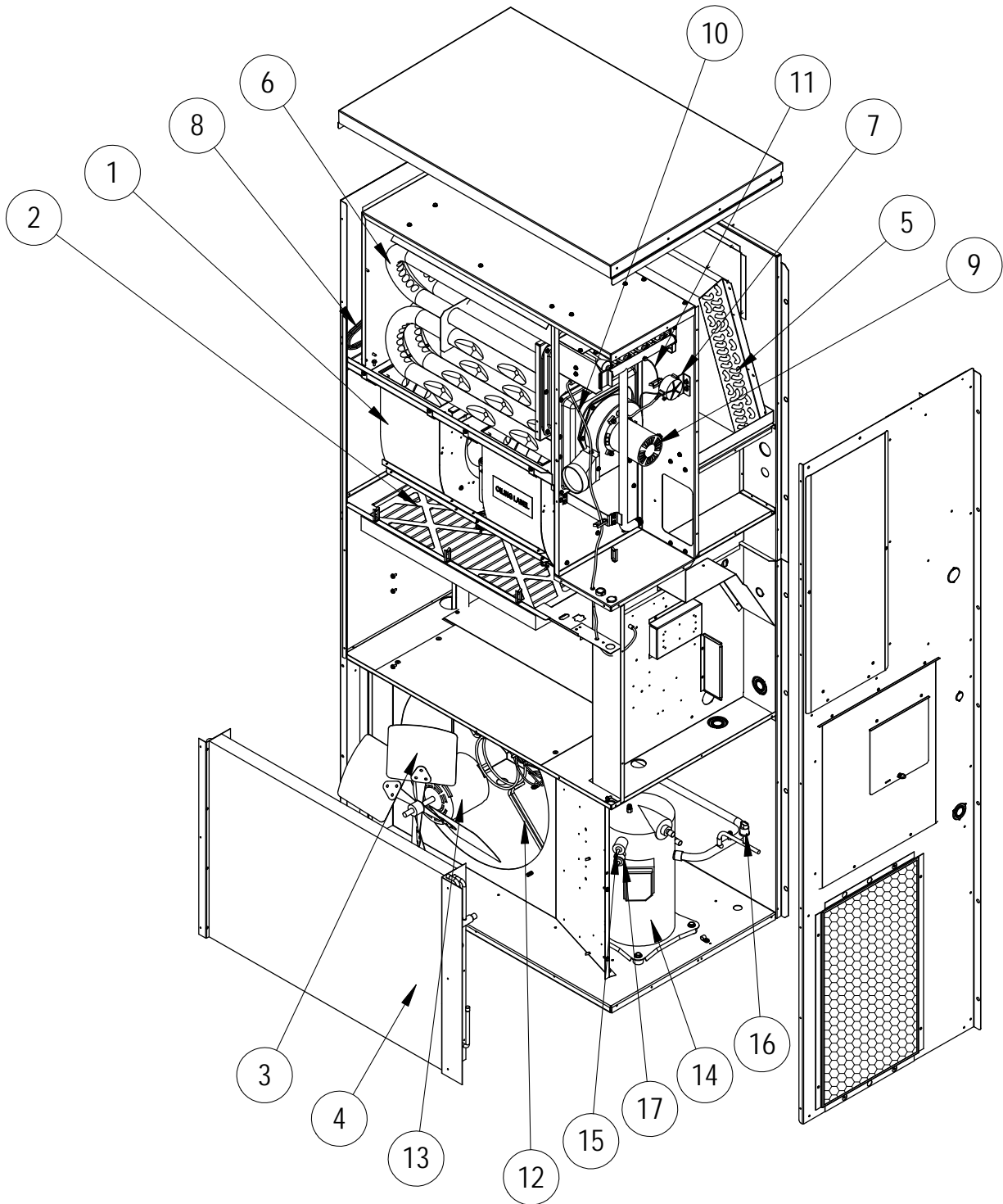

SEXP-677

This drawing to be used for reference for pages 7 and 8

FUNCTIONAL COMPONENTS - STANDARD

Drawing No.	Part No.	Description	W42G4-A	W42G4-B	W42G4-C	W48G4-A	W48G4-B	W48G4-C	W60G4-A	W60G4-B	W60G4-C
1	S900-377-001	Complete Blower Assembly 230/208	X	X							
1	S900-378-001	Complete Blower Assembly 460V			X						
1	S900-377-002	Complete Blower Assembly 230/208				X	X				
1	S900-378-002	Complete Blower Assembly 460V						X			
1	S900-377-003	Complete Blower Assembly 230/208							X	X	
1	S900-378-003	Complete Blower Assembly 460V									X
2	7004-027	20 x 30 x 2 Pleated Filter (Standard)	X	X	X	X	X	X	X	X	X
2	7003-030	20 x 30 x 1 AF Filter (Optional)	O	O	O	O	O	O	O	O	O
3	S5151-060	Fan Blade	X	X	X	X	X	X	X	X	X
4	5051-179BX	Condenser Coil	X	X	X						
4	5054-179BX	Coated Condenser Coil	O	O	O						
4	5051-180BX	Condenser Coil				X	X	X			
4	5054-180BX	Coated Condenser Coil				O	O	O			
4	5051-235BX	Condenser Coil							X	X	X
4	5054-235BX	Coated Condenser Coil							O	O	O
5	5060-106BX	Evaporator Coil	X	X	X	X	X	X			
5	5062-106BX	Coated Evaporator Coil	O	O	O	O	O	O			
5	5060-105BX	Evaporator Coil							X	X	X
5	5062-105BX	Coated Evaporator Coil							O	O	O
6	Heat Exch.	See Burner Components Diagram	X	X	X	X	X	X	X	X	X
7	8406-103	.55" + .05" Pressure Switch	X	X	X	X	X	X	X	X	X
8	S800-0448	Distributor/Orifice .070	X	X	X						
8	S800-0491	Distributor/Orifice .075				X	X	X			
8	S800-0490	Distributor/Orifice .084							X	X	X
9	8109-014	Induced Draft Blower 230V w/Transition	X	X		X	X		X	X	
9	8109-015	Induced Draft Blower 460V w/Transition			X			X			X
10	8600-011	Suppression Ignition Cable	X	X	X	X	X	X	X	X	X
11	3000-1615	Wire Assembly	X	X	X	X	X	X	X	X	X
12	8200-004	Fan Motor Mount	X	X	X	X	X	X	X	X	X
13	S8105-068	Motor 230/208V	X	X		X	X				
13	S8105-071	Motor 460V			X			X			
13	S8106-053	Motor 230/208V							X	X	
13	S8106-066	Motor 460V									X
14	8000-362	Compressor ZP36K5E-PFV-130	X								
14	8000-363	Compressor ZP36K5E-TF5-130		X							
14	8000-364	Compressor ZP36K5E-TFD-130			X						
14	8000-332	Compressor ZP42K5E-PFV-130				X					
14	8000-333	Compressor ZP42K5E-TF5-130					X				
14	8000-334	Compressor ZP42K5E-TFD-130						X			
14	8000-421	Compressor ZP61K6E-PFV-130							X		
14	8000-422	Compressor ZP61K6E-TF5-130								X	
14	8000-423	Compressor ZP61K6E-TFD-130									X
15	8406-142	High Pressure Switch	X	X	X	X	X	X	X	X	X
16	8406-140	Low Pressure Switch	X	X	X	X	X	X	X	X	X
17	S8406-105	Low Ambient Control (Part of CMA-46 LAC Kit)	O	O	O	O	O	O	O	O	O
NS	8408-048	Freeze Stat (Part of CMA-46 LAC Kit)	O	O	O	O	O	O	O	O	O
NS	CMA-46	Complete Low Ambient Kit	O	O	O	O	O	O	O	O	O
NS	6031-009	Coremax Valve Core	X	X	X	X	X	X	X	X	X

NS – Not Shown
X – Standard
O – Optional

FUNCTIONAL COMPONENTS – DEHUMIDIFICATION

Drawing No.	Part No.	Description	W42G4DA	W42G4DB	W42G4DC	W48G4DA	W48G4DB	W48G4DC	W60G4DA	W60G4DB	W60G4DC
1	900-377-001	Complete Blower Assembly 230/208	X	X							
1	900-378-001	Complete Blower Assembly 460V			X						
1	900-377-002	Complete Blower Assembly 230/208				X	X				
1	900-378-002	Complete Blower Assembly 460V						X			
1	900-377-003	Complete Blower Assembly 230/208							X	X	
1	900-378-003	Complete Blower Assembly 460V									X
2	7004-027	20 x 30 x 2 Pleated Filter (Standard)	X	X	X	X	X	X	X	X	X
2	7003-030	20 x 30 x 1 AF Filter (Optional)	O	O	O	O	O	O	O	O	O
3	S5151-060	Fan Blade	X	X	X	X	X	X	X	X	X
4	5051-179BX	Condenser Coil	X	X	X						
4	5054-179BX	Coated Condenser Coil	O	O	O						
4	5051-180BX	Condenser Coil				X	X	X			
4	5054-180BX	Coated Condenser Coil				O	O	O			
4	5051-235BX	Condenser Coil							X	X	X
4	5054-235BX	Coated Condenser Coil							O	O	O
5	917-0059BX	Evaporator Coil w/Reheat Coil	X	X	X	X	X	X			
5	917-0061BX	Coated Evaporator Coil w/Reheat Coil	O	O	O	O	O	O			
5	917-0060BX	Evaporator Coil w/Reheat Coil							X	X	X
5	917-0062BX	Coated Evaporator Coil w/Reheat Coil							O	O	O
6	Heat Exch.	See Burner Components Diagram	X	X	X	X	X	X	X	X	X
7	8406-103	.55" + .05" Pressure Switch	X	X	X	X	X	X	X	X	X
8	5625-008	Distributor	X	X	X	X	X	X			
8	5625-036	Distributor							X	X	X
9	8109-014	Induced Draft Blower 230V w/Transition	X	X		X	X		X	X	
9	8109-015	Induced Draft Blower 460V w/Transition			X			X			X
10	8600-011	Suppression Ignition Cable	X	X	X	X	X	X	X	X	X
11	3000-1615	Wire Assembly	X	X	X	X	X	X	X	X	X
12	8200-004	Fan Motor Mount	X	X	X	X	X	X	X	X	X
13	S8105-066	Motor 230/208V	X	X		X	X				
13	S8105-071	Motor 460V			X			X			
13	S8106-053	Motor 230/208V							X	X	
13	S8106-066	Motor 460V									X
14	8000-362	Compressor ZP36K5E-PFV-130	X								
14	8000-363	Compressor ZP36K5E-TF5-130		X							
14	8000-364	Compressor ZP36K5E-TFD-130			X						
14	8000-332	Compressor ZP42K5E-PFV-130				X					
14	8000-333	Compressor ZP42K5E-TF5-130					X				
14	8000-334	Compressor ZP42K5E-TFD-130						X			
14	8000-421	Compressor ZP61K6E-PFV-130							X		
14	8000-422	Compressor ZP61K6E-TF5-130								X	
14	8000-423	Compressor ZP61K6E-TFD-130									X
15	8406-142	High Pressure Switch	X	X	X	X	X	X	X	X	X
16	8406-140	Low Pressure Switch	X	X	X	X	X	X	X	X	X
17	S8406-105	Low Ambient Control (Part of CMA-45 LAC Kit)	O	O	O	O	O	O	O	O	O
NS	CMA-45	Low Ambient Control	O	O	O	O	O	O	O	O	O
NS	8408-048	Freeze Thermostat	X	X	X	X	X	X	X	X	X
NS	5651-245	Expansion Valve	X	X	X	X	X	X			
NS	5651-248	Expansion Valve							X	X	X
NS	5651-219	Check Valve	X	X	X	X	X	X	X	X	X
NS	5650-048	Molded Plug	X	X	X	X	X	X	X	X	X
NS	5650-051	Three Way Valve with Solenoid	X	X	X	X	X	X	X	X	X
NS	5201-022	Filter Drier	X	X	X	X	X	X	X	X	X
NS	5650-046	Solenoid Coil 24V	X	X	X	X	X	X	X	X	X
NS	6031-009	Coremax Valve Core	X	X	X	X	X	X	X	X	X

NS – Not Shown
 X – Standard
 O – Optional

Refer to drawing on page 6

This page intentionally left blank

BURNER COMPONENTS - STANDARD & DEHUMIDIFICATION

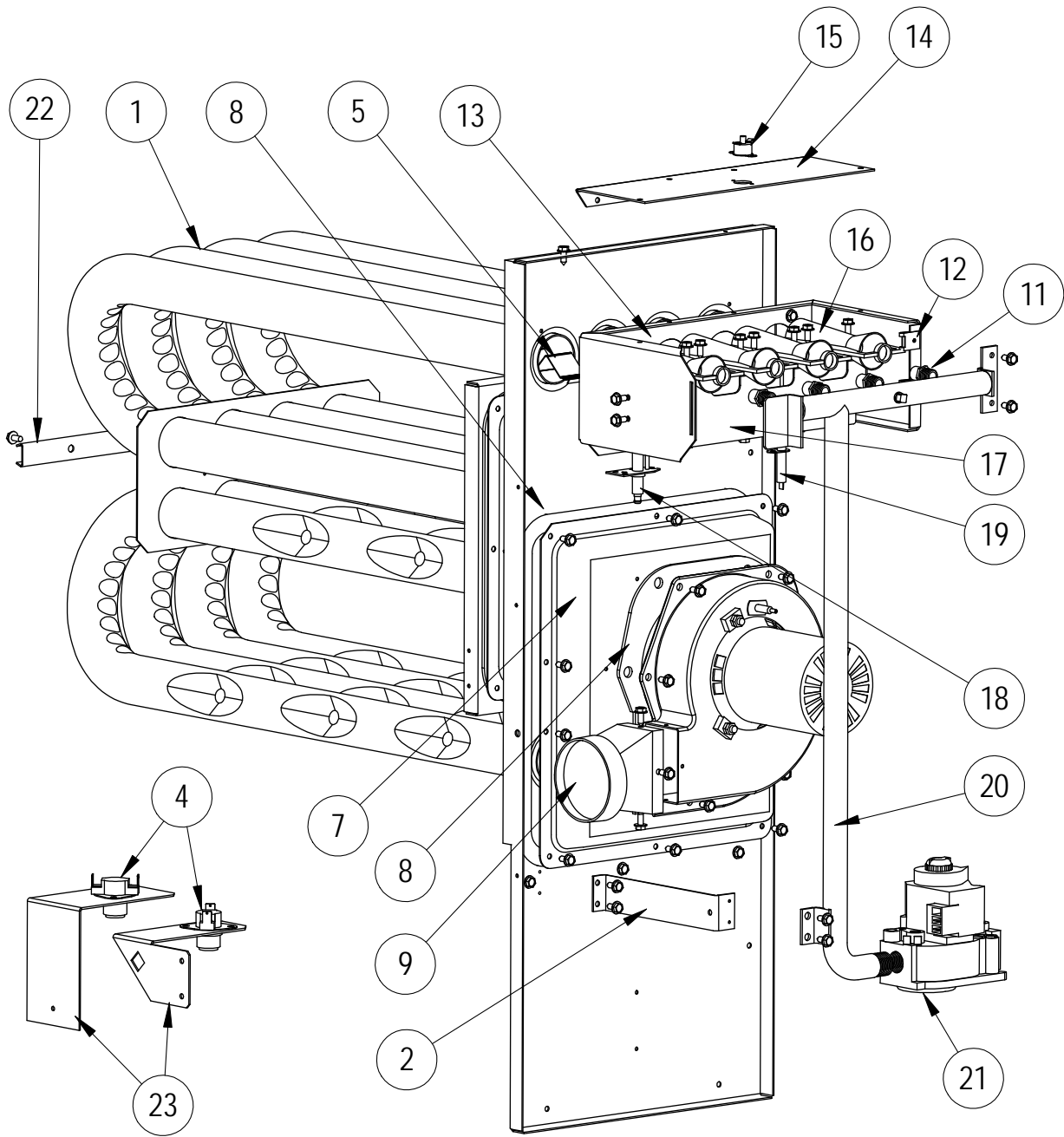

SEXP-678 A

This drawing to be used for reference for pages 11, 12 and 13

BURNER COMPONENTS – STANDARD & DEHUMIDIFICATION

Drawing No.	Part No.	Description	W42G4**XB	W42G4**NB	W42G4**XC	W42G4**NC	W42G4**XD
1	S171-315	Heat Exchanger Assembly 75K	X	X			
1	S171-317	Heat Exchanger Assembly 100K			X	X	
1	S171-319	Heat Exchanger Assembly 125K					X
2	113-268	Manifold Bracket	X	X	X	X	X
4	8402-180	Limit Control L140-30	X	X			
4	8402-178	Limit Control L120-30			X	X	
4	8402-177	Limit Control L115-30					X
5	9010-083	NOx Screen		3		4	
6	1921-025-4600	46" Glas-Tak Tape	X	X	X	X	X
7	168-126	Collector Box	X	X			
7	168-127	Collector Box			X	X	
7	168-128	Collector Box					X
8	1921-044	Gasket Set	X	X	X	X	X
9	5809-013	3" Cast Inducer Transition	X	X	X	X	X
10	5809-017	3.031" x 4.625" Transition	X	X	X	X	X
11	9010-079	Orifice 2.40mm (.0960 diameter)	3		4		5
11	9010-082	Orifice 2.30mm (10% derate & .0905 diameter)	3	3	4	4	5
12	1012-314	U Clip Fastener	4	4	4	4	4
13	163-049	Burner Box	X	X			
13	163-052	Burner Box			X	X	
13	163-051	Burner Box					X
14	141-493	Flame Rollout Support	X	X			
14	141-494	Flame Rollout Support			X	X	
14	141-439	Flame Rollout Support					X
15	8402-124	Flame Rollout Switch L270	X	X	X	X	X
16	9010-078	In-Shot Burner 2.5 x 4.5	3	3	4	4	5
17	163-041	Burner Support	X	X			
17	163-043	Burner Support			X	X	
17	163-045	Burner Support					X
18	8554-024	DSI Spark Igniter	X	X	X	X	X
19	8554-025	Flame Sensor	X	X	X	X	X
20	5818-054	3-Hole Gas Manifold - 1/2"	X	X			
20	5818-055	4-Hole Gas Manifold - 1/2"			X	X	
20	5818-056	5-Hole Gas Manifold - 1/2"					X
21	5651-160	Natural Gas Valve 1/2 x 1/2	X	X	X	X	X
22	168-135	Tube Brace 3 Burner	X	X			
22	168-134	Tube Brace 4 Burner			X	X	
22	168-133	Tube Brace 5 Burner					X
23	112-475	Limit Bracket	X	X	X	X	X
NS	S400-0183	Orifice Parts Bag 3 Tube 75K	X	X			
NS	S400-0184	Orifice Parts Bag 4 Tube 100K			X	X	
NS	S400-0185	Orifice Parts Bag 5 Tube 125K					X
NS	8600-011	Ignition Cable	X	X	X	X	X

NS – Not Shown

BURNER COMPONENTS – STANDARD & DEHUMIDIFICATION

Drawing No.	Part No.	Description	W48G4**XB	W48G4**NB	W48G4**XC	W48G4**NC	W48G4**XD
1	S171-315	Heat Exchanger Assembly 75K	X	X			
1	S171-317	Heat Exchanger Assembly 100K			X	X	
1	S171-319	Heat Exchanger Assembly 125K					X
2	113-268	Manifold Bracket	X	X	X	X	X
4	8402-180	Limit Control L140-30	X	X			
4	8402-178	Limit Control L120-30			X	X	
4	8402-177	Limit Control L115-30					X
5	9010-083	NOx Screen		3		4	
6	1921-025-4600	46" Glas-Tak Tape	X	X	X	X	X
7	168-126	Collector Box	X	X			
7	168-127	Collector Box			X	X	
7	168-128	Collector Box					X
8	1921-044	Gasket Set	X	X	X	X	X
9	5809-013	3" Cast Inducer Transition	X	X	X	X	X
10	5809-017	3.031" x 4.625" Transition	X	X	X	X	X
11	9010-079	Orifice 2.40mm (.0960 diameter)	3		4		5
11	9010-082	Orifice 2.30mm (10% derate & .0905 diameter)	3	3	4	4	5
12	1012-314	U Clip Fastener	4	4	4	4	4
13	163-049	Burner Box	X	X			
13	163-052	Burner Box			X	X	
13	163-051	Burner Box					X
14	141-493	Flame Rollout Support	X	X			
14	141-494	Flame Rollout Support			X	X	
14	141-439	Flame Rollout Support					X
15	8402-124	Flame Rollout Switch L270	X	X	X	X	X
16	9010-078	In-Shot Burner 2.5 x 4.5	3	3	4	4	5
17	163-041	Burner Support	X	X			
17	163-043	Burner Support			X	X	
17	163-045	Burner Support					X
18	8554-024	DSI Spark Igniter	X	X	X	X	X
19	8554-025	Flame Sensor	X	X	X	X	X
20	5818-054	3-Hole Gas Manifold - 1/2"	X	X			
20	5818-055	4-Hole Gas Manifold - 1/2"			X	X	
20	5818-056	5-Hole Gas Manifold - 1/2"					X
21	5651-160	Natural Gas Valve 1/2 x 1/2	X	X	X	X	X
22	168-135	Tube Brace 3 Burner	X	X			
22	168-134	Tube Brace 4 Burner			X	X	
22	168-133	Tube Brace 5 Burner					X
23	112-475	Limit Bracket	X	X	X	X	X
NS	S400-0183	Orifice Parts Bag 3 Tube 75K	X	X			
NS	S400-0184	Orifice Parts Bag 4 Tube 100K			X	X	
NS	S400-0185	Orifice Parts Bag 5 Tube 125K					X
NS	8600-011	Ignition Cable	X	X	X	X	X

NS – Not Shown

Refer to drawing on page 10

BURNER COMPONENTS – STANDARD & DEHUMIDIFICATION

Drawing No.	Part No.	Description	W60G4**XB	W60G4**NB	W60G4**XC	W60G4**NC	W60G4**XD
1	S171-315	Heat Exchanger Assembly 75K	X	X			
1	S171-317	Heat Exchanger Assembly 100K			X	X	
1	S171-319	Heat Exchanger Assembly 125K					X
2	113-268	Manifold Bracket	X	X	X	X	X
4	8402-180	Limit Control L140-30	X	X			
4	8402-178	Limit Control L120-30			X	X	
4	8402-177	Limit Control L115-30					X
5	9010-083	NOx Screen		3		4	
6	1921-025-4600	46" Glas-Tak Tape	X	X	X	X	X
7	168-126	Collector Box	X	X			
7	168-127	Collector Box			X	X	
7	168-128	Collector Box					X
8	1921-044	Gasket Set	X	X	X	X	X
9	5809-013	3" Cast Inducer Transition	X	X	X	X	X
10	5809-017	3.031" x 4.625" Transition	X	X	X	X	X
11	9010-079	Orifice 2.40mm (.0960 diameter)	3		4		5
11	9010-082	Orifice 2.30mm (10% derate & .0905 diameter)	3	3	4	4	5
12	1012-314	U Clip Fastener	4	4	4	4	4
13	163-049	Burner Box	X	X			
13	163-052	Burner Box			X	X	
13	163-051	Burner Box					X
14	141-493	Flame Rollout Support	X	X			
14	141-494	Flame Rollout Support			X	X	
14	141-439	Flame Rollout Support					X
15	8402-124	Flame Rollout Switch L270	X	X	X	X	X
16	9010-078	In-Shot Burner 2.5 x 4.5	3	3	4	4	5
17	163-041	Burner Support	X	X			
17	163-043	Burner Support			X	X	
17	163-045	Burner Support					X
18	8554-024	DSI Spark Igniter	X	X	X	X	X
19	8554-025	Flame Sensor	X	X	X	X	X
20	5818-054	3-Hole Gas Manifold - 1/2"	X	X			
20	5818-055	4-Hole Gas Manifold - 1/2"			X	X	
20	5818-056	5-Hole Gas Manifold - 1/2"					X
21	5651-160	Natural Gas Valve 1/2 x 1/2	X	X	X	X	X
22	168-135	Tube Brace 3 Burner	X	X			
22	168-134	Tube Brace 4 Burner			X	X	
22	168-133	Tube Brace 5 Burner					X
23	112-475	Limit Bracket	X	X	X	X	X
NS	S400-0183	Orifice Parts Bag 3 Tube 75K	X	X			
NS	S400-0184	Orifice Parts Bag 4 Tube 100K			X	X	
NS	S400-0185	Orifice Parts Bag 5 Tube 125K					X
NS	8600-011	Ignition Cable	X	X	X	X	X

NS – Not Shown

Refer to drawing on page 10

CONTROL PANEL - STANDARD & DEHUMIDIFICATION

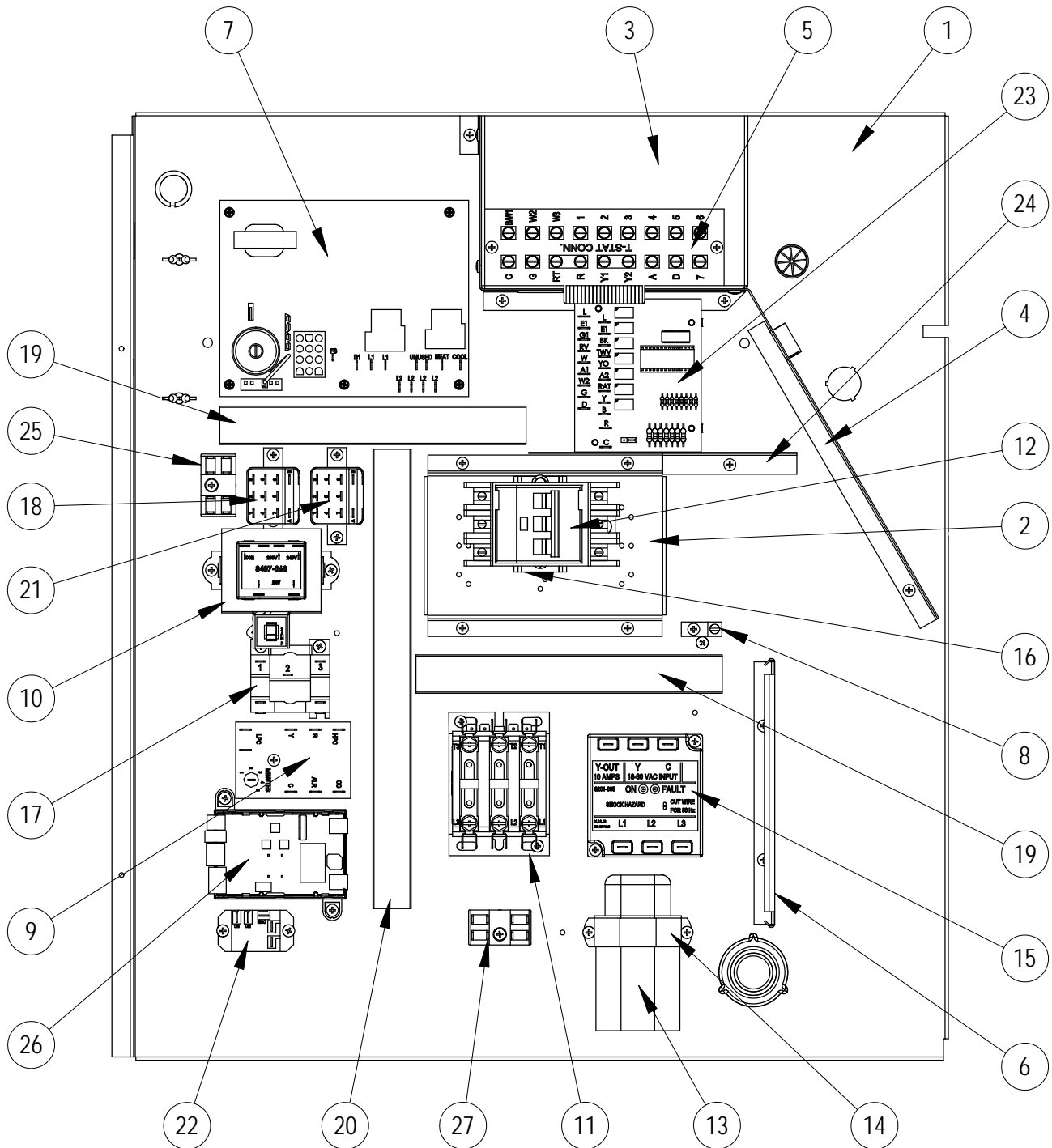

SEXP-1013

This drawing to be used for reference for pages 15 and 16

CONTROL PANEL - STANDARD

Drawing No.	Part No.	Description	W42G4-A	W42G4-B	W42G4-C	W48G4-A	W48G4-B	W48G4-C	W60G4-A	W60G4-B	W60G4-C
1	517-408	Control Panel	X	X	X	X	X	X	X	X	X
2	113-269	Circuit Breaker Mounting Bracket	X	X	X	X	X	X	X	X	X
3	117-410	Low Voltage Box	X	X	X	X	X	X	X	X	X
4	117-409	Low Voltage Partition	X	X	X	X	X	X	X	X	X
5	8607-062	Terminal Strip	X	X	X	X	X	X	X	X	X
6	135-130	Wire Shield	X	X	X	X	X	X	X	X	X
7	5651-159	Integrated Furnace Control	X	X	X	X	X	X	X	X	X
8	8611-006	Terminal	X	X	X	X	X	X	X	X	X
9	S8201-164	Compressor Control Module	X	X	X	X	X	X	X	X	X
10	8407-068	Transformer	X	X		X	X		X	X	
10	8407-069	Transformer			X			X			X
11	S8401-002	Compressor Contactor		X	X		X	X		X	X
11	S8401-025	Compressor Contactor	X			X			X		
12	S8615-095	600V 40A Toggle Disconnect			X			X			X
12	S8615-096	600V Switch Cover Plate			X			X			X
12	S8615-043	230V 40A Circuit Breaker								X	
12	S8615-052	230V 30A Circuit Breaker		X			X				
12	S8615-040	230V 50A Circuit Breaker				X			X		
12	S8615-055	230V 40A Circuit Breaker	X								
13	S8552-004	Outdoor Fan Capacitor			X			X			
13	S8552-005	Outdoor Fan Capacitor		X			X				
13	S8552-036	Outdoor Fan Capacitor						X			
13	S8552-089	Outdoor Fan Capacitor				X					
13	S8552-052	Outdoor Fan Capacitor	X								
14	8550-003	Capacitor Bracket		X	X		X	X			
14	8550-008	Capacitor Bracket	X			X			X		
15	8201-126	Phase Monitor		X	X		X	X		X	X
16	8611-209	DIN Rail		X	X		X	X		X	X
16	8611-210	DIN Rail	X			X			X		
17	8201-032	Inducer Relay	X	X	X	X	X	X	X	X	X
18	8201-130	Blower Relay	X	X	X	X	X	X	X	X	X
19	8611-140-0800	Cable Duct - 8" x 1" Wide	2	2	2	2	2	2	2	2	2
20	8611-140-1200	Cable Duct - 12" x 1" Wide	X	X	X	X	X	X	X	X	X
24	135-266	Wire Shield	X	X	X	X	X	X	X	X	X
25	8607-017	Terminal Block	X	X	X	X	X	X	X	X	X
27	8607-017	Terminal Block - LAC Kit	O	O	O	O	O	O	O	O	O
NS	4085-175	Wiring Diagram	X			X			X		
NS	4085-177	Wiring Diagram								X	
NS	4085-275	Wiring Diagram		X			X				
NS	4085-277	Wiring Diagram									X
NS	4085-398	Wiring Diagram			X			X			
NS	4085-400	Wiring Diagram						X			
NS	3000-1616	Blower Power Plug	X	X	X	X	X	X	X	X	X
NS	3000-1617	Blower Speed Plug	X	X	X	X	X	X	X	X	X
NS	3000-1224	Compressor Plug/Harness	X			X			X		
NS	3000-1231	Compressor Plug/Harness		X	X		X	X		X	X
NS	3003-075	Control Panel Wire Harness		X	X		X	X		X	X
NS	3003-076	Control Panel Wire Harness	X			X			X		
NS	3000-1618	Integrated Furnace Control Plug	X	X	X	X	X	X	X	X	X

NS - Not Shown
X - Standard
O - Optional

CONTROL PANEL – DEHUMIDIFICATION

Drawing No.	Part No.	Description	W42G4DA	W42G4DB	W42G4DC	W48G4DA	W48G4DB	W48G4DC	W60G4DA	W60G4DB	W60G4DC
1	517-408	Control Panel	X	X	X	X	X	X	X	X	X
2	113-269	Circuit Breaker Mounting Bracket	X	X	X	X	X	X	X	X	X
3	117-410	Low Voltage Box	X	X	X	X	X	X	X	X	X
4	117-409	Low Voltage Partition	X	X	X	X	X	X	X	X	X
5	8607-062	Terminal Strip	X	X	X	X	X	X	X	X	X
6	135-130	Wire Shield	X	X	X	X	X	X	X	X	X
7	5651-159	Integrated Furnace Control	X	X	X	X	X	X	X	X	X
8	8611-006	Terminal	X	X	X	X	X	X	X	X	X
9	S8201-164	Compressor Control Module	X	X	X	X	X	X	X	X	X
10	8407-068	Transformer	X	X		X	X		X	X	
10	8407-069	Transformer			X			X			X
11	S8401-002	Compressor Contactor		X	X		X	X		X	X
11	S8401-025	Compressor Contactor	X			X			X		
12	S8615-095	600V 40A Toggle Disconnect			X			X			X
12	S8615-096	600V Switch Cover Plate			X			X			X
12	S8615-043	230V 40A Circuit Breaker								X	
12	S8615-052	230V 30A Circuit Breaker		X			X				
12	S8615-040	230V 50A Circuit Breaker				X			X		
12	S8615-055	230V 40A Circuit Breaker	X								
13	S8552-004	Outdoor Fan Capacitor			X			X			
13	S8552-005	Outdoor Fan Capacitor		X			X				
13	S8552-036	Outdoor Fan Capacitor							X		
13	S8552-089	Outdoor Fan Capacitor				X					
13	S8552-052	Outdoor Fan Capacitor	X								
14	8550-003	Capacitor Bracket		X	X		X	X			
14	8550-008	Capacitor Bracket	X			X			X		
15	8201-126	Phase Monitor		X	X		X	X		X	X
16	8611-209	DIN Rail		X	X		X	X		X	X
16	8611-210	DIN Rail	X			X			X		
17	8201-032	Inducer Relay	X	X	X	X	X	X	X	X	X
18	8201-159	Blower Relay	X	X	X	X	X	X	X	X	X
19	8611-140-0800	Cable Duct - 8" x 1" Wide	2	2	2	2	2	2	2	2	2
20	8611-140-1200	Cable Duct - 12" x 1" Wide	X	X	X	X	X	X	X	X	X
21	8201-159	Lockout Relay	X	X	X	X	X	X	X	X	X
22	8201-130	Dehumidification Control Relay	X	X	X	X	X	X	X	X	X
23	8201-113	Dehumidification Logic Board	X	X	X	X	X	X	X	X	X
24	135-266	Wire Shield	X	X	X	X	X	X	X	X	X
25	8607-017	Terminal Block	X	X	X	X	X	X	X	X	X
26	8301-079	EEV Control Board	X	X	X	X	X	X	X	X	X
27	8607-017	Terminal Block - LAC Kit	O	O	O	O	O	O	O	O	O
NS	4085-171	Wiring Diagram				X			X		
NS	4085-173	Wiring Diagram	X								
NS	4085-271	Wiring Diagram								X	
NS	4085-273	Wiring Diagram		X			X				
NS	4085-394	Wiring Diagram									X
NS	4085-396	Wiring Diagram			X			X			
NS	3000-1616	Blower Power Plug	X	X	X	X	X	X	X	X	X
NS	3000-1617	Blower Speed Plug	X	X	X	X	X	X	X	X	X
NS	3000-1224	Compressor Plug/Harness	X			X			X		
NS	3000-1231	Compressor Plug/Harness		X	X		X	X		X	X
NS	3003-070	Control Panel Wire Harness		X	X		X	X		X	X
NS	3003-074	Control Panel Wire Harness	X			X			X		
NS	3000-1618	Integrated Furnace Control Plug	X	X	X	X	X	X	X	X	X

NS - Not Shown
 X - Standard
 O - Optional

Refer to drawing on page 14

BLOWER ASSEMBLY

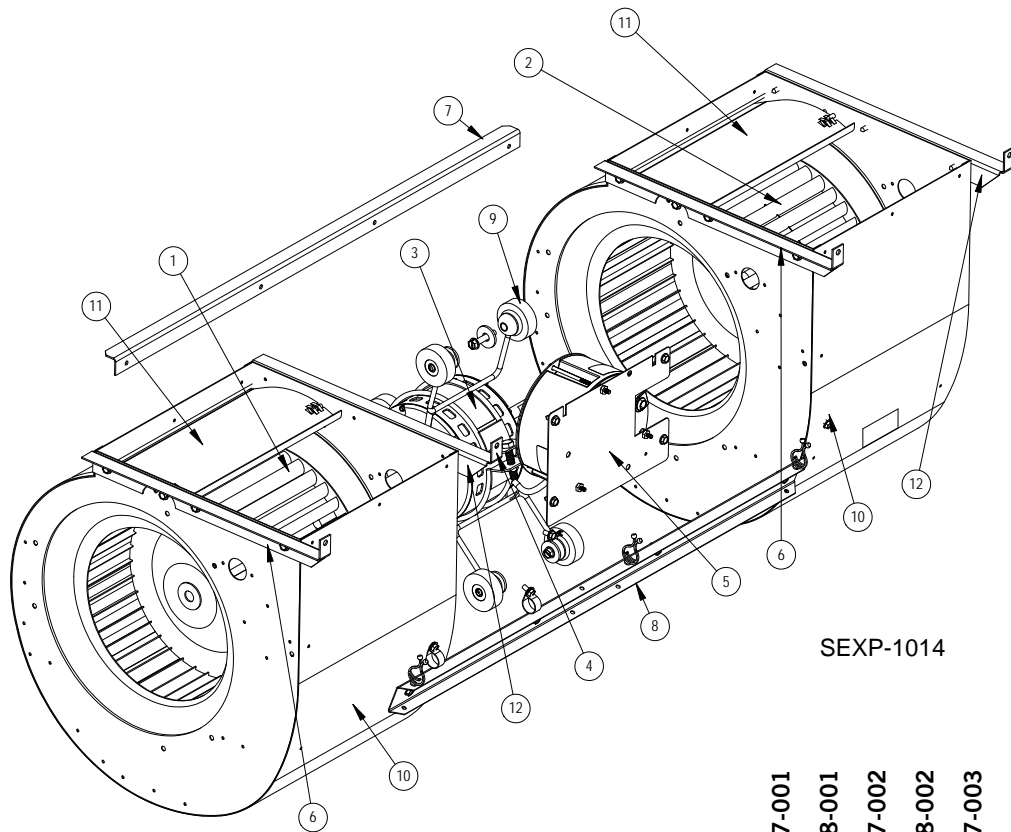

SEXP-1014

Drawing No.	Part No.	Description	900-377-001	900-378-001	900-377-002	900-378-002	900-377-003	900-378-003
1	5152-096	Blower Wheel	X	X	X	X	X	X
2	5152-072	Blower Wheel	X	X	X	X	X	X
3	S8107-028-0189	Blower Motor & Control (230/208V)	X					
3	S8107-028-0190	Blower Motor & Control (230/208V)		X				
3	S8107-028-0191	Blower Motor & Control (230/208V)			X			
3	S8107-029-0195	Blower Motor & Control (460V)				X		
3	S8107-029-0196	Blower Motor & Control (460V)					X	
3	S8107-029-0197	Blower Motor & Control (460V)						X
3	C8107-028-0189	Programmed Control Only (230/208V)	X					
3	C8107-028-0190	Programmed Control Only (230/208V)		X				
3	C8107-028-0191	Programmed Control Only (230/208V)			X			
3	C8107-029-0195	Programmed Control Only (460V)				X		
3	C8107-029-0196	Programmed Control Only (460V)					X	
3	C8107-029-0197	Programmed Control Only (460V)						X
4	8200-040	Motor Mount	X	X	X	X	X	X
5	112-775	Motor Control Bracket	X	X	X	X	X	X
6	105Y1075	Angle – Left	2	2	2	2	2	2
7	105-1109	Angle – Back	X	X	X	X	X	X
8	165-572	Channel – Front	X	X	X	X	X	X
9	5451-011	Grommet	6	6	6	6	6	6
10	151-117	Blower Housing	2	2	2	2	2	2
11	144-167	Diffuser	2	2	2	2	2	2
12	105X1075	Angle – Right	2	2	2	2	2	2