REPLACEMENT PARTS MANUAL

Electric Heat Packages

Models:

EHW3HC-A04	EHW4HC-A15	EHW3HCDB15
EHW3HC-A05	EHW4HC-B09	EHW3HCDC05
EHW3HC-A10	EHW4HC-C05	EHW3HCDC09
EHW3HC-A15	EHW4HC-C09	EHW3HCDC15
EHW3HC-B05	EHW6HC-A05	EHW4HCDA05
EHW3HC-B09	EHW6HC-A10	EHW4HCDB05
EHW3HC-B15	EHW6HC-B09	EHW6HCDA05
EHW3HC-C05	EHW6HC-C09	EHW6HCDA10
EHW3HC-C15	EHW3HCDA10	EHW6HCDB09
EHW4HC-A04	EHW3HCDA15	EHW6HCDC09
EHW4HC-A05	EHW3HCDB09	

Contents

Description	Page
Functional Components	
♦ Layout View	2
♦ Usage List	3
♦ Usage List	4

General Notes

- Revised and/or additional pages may be issued from time to time.
- A complete and current manual consists of pages shown in the following contents section.

Important

- Contact the installing and/or local Bard distributor for all parts requirements. Make sure to have the complete model and serial number available from the unit rating plates.



Climate Control Solutions

Bard Manufacturing Company, Inc.
Bryan, Ohio 43506
www.bardhvac.com

Manual: 2110-630A
Supersedes: 2110-630
Date: 1-8-20

FUNCTIONAL COMPONENTS

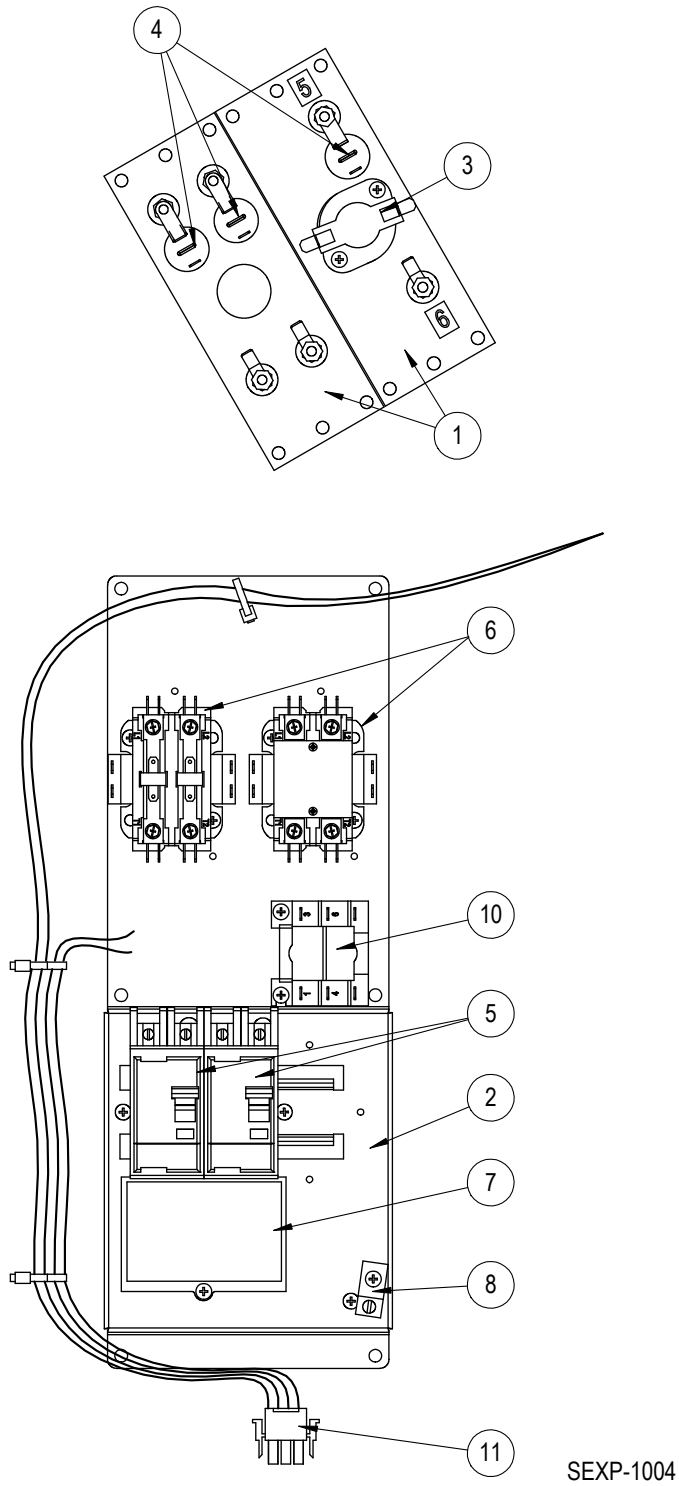

SEXP-1004

FUNCTIONAL COMPONENTS

Dwg. No.	Part No.	Description	EHW3HC-A04	EHW3HC-A05	EHW3HC-A10	EHW3HC-A15	EHW3HC-B05	EHW3HC-B09	EHW3HC-B15	EHW4HC-A04	EHW4HC-A05	EHW6HC-A05	EHW6HC-A10	EHW6HC-B09	EHW6HC-C09	EHW6HCDA05	EHW6HCDA10	EHW6HCDB09	EHW6HCDC09
1	8604-048	Heat Strip 9KW						X	X					X					
1	8604-049	Heat Strip 6KW							X										
1	8604-088	Heat Strip 4KW	X							X									
1	8604-089	Heat Strip 5KW		X		X					X	X				X			
1	8604-091	Heat Strip 10KW			X	X							X				X		
1	8604-101	Heat Strip 9KW													X				X
1	8604-121	Heat Strip 9KW																X	
1	8604-154	Heat Strip 5KW					X												
2	127-575	Heater Control Base	X	X	X	X	X	X	X	X	X	X	X	X		X	X	X	X
2	127-585	Heater Control Base												X					X
3	8402-031	Limit Control					X			X	X				X				X
3	8402-033	Limit Control																	
3	8402-074	Limit Control	X	X	X							X	X			X	X		
3	8402-075	Limit Control				X													
3	8402-118	Limit Control						X											
3	8402-119	Limit Control																X	
3	8402-141	Limit Control							X										
4	8402-019	Thermal Cutoff	1	1															
4	8402-091	Thermal Cutoff					2							2					
4	S8402-092	Thermal Cutoff						2	4	1	1								
4	S8402-094	Thermal Cutoff																2	2
4	S8402-096	Thermal Cutoff			1	1						1	2			1	2		
4	8402-128	Thermal Cutoff												2					
5	8615-037	Circuit Breaker 30A			X						X					X			
5	8615-039	Circuit Breaker 45A				X											X		
5	8615-040	Circuit Breaker 50A								X							X	X	
5	8615-041	Circuit Breaker 60A	X	X	X	X				X		X	2				X		
5	8615-043	Circuit Breaker 40A												X					
5	8615-044	Circuit Breaker 45A					X												
5	8615-046	Circuit Breaker 60A						X	X									X	
5	S8615-067	Toggle Disconnect 40A													X				X
5	8615-069	Toggle Cover Plate													X				X
6	S8401-002	Contact 3-POLE 25 AMP					X	X	2					X	X			X	X
6	S8401-006	Contact 2-POLE 20 AMP				X													
6	8401-025	Contact 2-POLE 40 AMP			X	X				X			X				X		
6	8401-033	Contact 2-POLE 40 AMP	X	X						X		X				X			
7	8615-047	Jumper Bar			X	X					X		X			X	X		
8	8611-006	Terminal	X	X	X	X	X	X	X	X	X	X	X	X	X	X	X	X	X
9	8615-049	Jumper Bar Cover			X	X				X			X			X	X		
9	8615-061	Cover Plate					X		X					X			X	X	
11	3000-1640	Wire Assembly	X	X	X					X	X	X	X			X	X		
11	3000-1644	Wire Assembly					X	X						X	X			X	X
11	3000-1671	Wire Assembly				X													
11	3000-1675	Wire Assembly							X										
NS	4097-1011	Wiring Diagram	X	X						X		X							
NS	4097-1016	Wiring Diagram				X													
NS	4097-1017	Wiring Diagram			X								X				X		
NS	4097-1020	Wiring Diagram														X			
NS	4097-255	Wiring Diagram					X	X			X			X				X	
NS	4097-260	Wiring Diagram							X										
NS	4097-344	Wiring Diagram													X				X

NS – Not Shown

FUNCTIONAL COMPONENTS

Dwg. No.	Part No.	Description	EHW3HC-C05	EHW3HC-C15	EHW3HCDA10	EHW3HCDA15	EHW3HCDB09	EHW3HCDB15	EHW3HCDC05	EHW3HCDC09	EHW3HCDC15	EHW4HC-A15	EHW4HC-B09	EHW4HC-C05	EHW4HC-C09	EHW4HCDA05	EHW4HCDB05
1	8604-048	Heat Strip 9KW					X	X					X				
1	8604-049	Heat Strip 6KW						X									
1	8604-089	Heat Strip 5KW				X						X				X	
1	8604-091	Heat Strip 10KW			X	X						X					
1	8604-100	Heat Strip 6KW		X							X						
1	8604-101	Heat Strip 9KW		X						X	X				X		
1	8604-146	Heat Strip 5KW															X
1	8604-155	Heat Strip 5KW	X						X					X			
2	127-575	Heater Control Base			X	X	X	X				X	X			X	X
2	127-585	Heater Control Base	X	X					X	X	X			X	X		
3	8402-033	Limit Control							X							X	X
3	8402-074	Limit Control			X												
3	8402-075	Limit Control				X											
3	8402-113	Limit Control						X									
3	8402-118	Limit Control							X					X			
3	8402-119	Limit Control	X				X						X		X		
3	8402-193	Limit Control		X							X	X					
4	8402-091	Thermal Cutoff					2					3	2				2
4	8402-093	Thermal Cutoff			2	3											
4	S8402-096	Thermal Cutoff														2	
4	8402-128	Thermal Cutoff	2	4				4	2	2	4			2	2		
4	8402-191	Thermal Cutoff						4									
5	8615-037	Circuit Breaker 30A			X	X										X	
5	8615-039	Circuit Breaker 45A														X	
5	8615-040	Circuit Breaker 50A										X					
5	8615-041	Circuit Breaker 60A			X	X						X					
5	8615-045	Circuit Breaker 50A															X
5	8615-046	Circuit Breaker 60A					X	X					X				
5	8615-067	Toggle Disconnect 40A	X	X					X	X	X			X	X		
5	8615-069	Switch Cover Plate	X	X					X	X	X			X	X		
6	S8401-002	Contactors 3-POLE 25 AMP	X	2			X	2	X	X	2		X	X	X		X
6	S8401-006	Contactors 2-POLE 20 AMP				X						X					
6	8401-025	Contactors 2-POLE 40 AMP			X	X						X				X	
7	8615-047	Jumper Bar			X											X	
8	8611-006	Terminal	X	X	X	X	X	X	X	X	X	X	X	X	X	X	X
9	8615-049	Jumper Bar Cover			X	X						X				X	
9	8615-061	Cover Plate					X	X						X	X		X
11	3000-1640	Wire Assembly			X											X	
11	3000-1643	Wire Assembly		X							X						
11	3000-1644	Wire Assembly	X				X		X	X			X	X	X		X
11	3000-1671	Wire Assembly				X						X					
11	3000-1675	Wire Assembly						X									
NS	4097-1016	Wiring Diagram			X							X					
NS	4097-1017	Wiring Diagram															
NS	4097-1020	Wiring Diagram														X	
NS	4097-1024	Wiring Diagram		X													
NS	4097-255	Wiring Diagram					X						X				X
NS	4097-260	Wiring Diagram						X									
NS	4097-344	Wiring Diagram	X						X	X				X	X		
NS	4097-345	Wiring Diagram									X						

NS – Not Shown