Replacement Parts Manual

Q/TEC Series Packaged Heat Pump

Models:

QH241 QH301
QH361 QH421

General Notes

- Revised and/or additional pages may be issued from time to time.
- A complete and current manual consists of pages shown in the following contents section.

Contents

Description	Page
Cabinet Components	
♦ Exploded View	1
♦ Usage List	2
Functional Components	
♦ Exploded View	3
♦ Usage List	4
♦ Usage List	5
♦ Blank Page	6
Control Panel Components	
♦ Exploded View	7
♦ Usage List	8
Blower Assembly Components	
♦ Exploded View	9
♦ Usage List	10
Optional Climate Control Components	
♦ Exploded View	11
♦ Usage List	12
Optional Heater Components	
♦ Exploded View	13
♦ Usage List	14
♦ Usage List	15
♦ Usage List	16



BARD MANUFACTURING COMPANY
Bryan, Ohio 43506

Since 1914...Moving ahead, just as planned.

Manual: 2110-523C
Supersedes: Rev. B
File: Vol II Tab 14
Date: 02-10-97

CABINET COMPONENTS

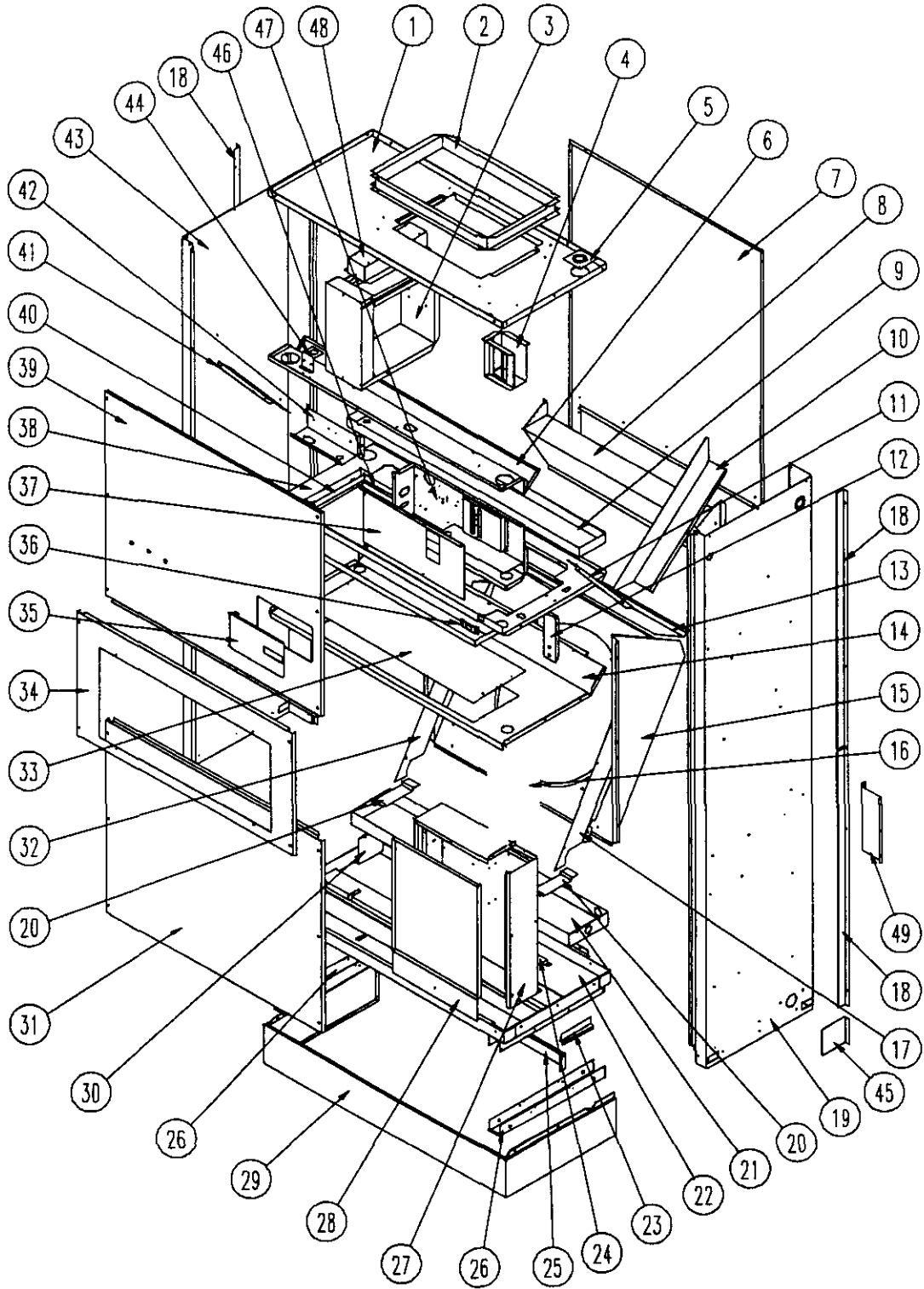

SEXP-239

CABINET COMPONENTS

Drawing No.	Part No.	Description	QH241-A, B	QH241-C	QH301-A, B	QH301-C	QH361-A, B	QH361-C	QH421-A, B	QH421-C
1	S506-187	Top Assembly	X	X	X	X	X	X	X	X
2	110-044	Outlet Duct Flange	X	X	X	X	X	X	X	X
3		Heater Package Assembly	X	X	X	X	X	X	X	X
4	117-187	Low Voltage Box Assembly	X	X	X	X	X	X	X	X
5	136-359	T. K. O. Plate	X	X	X	X	X	X	X	X
6	534-153	Evaporator Coil Shield Assembly	X	X	X	X	X	X	X	X
7	508-133	Back Assembly	X	X	X	X	X	X	X	X
8	S538-106	Fresh Air Damper Assembly	X	X	X	X	X	X	X	X
9	523-093	Evaporator Drain Pan Assembly	X	X	X	X	X	X	X	X
10	134-154	Evaporator Wire Channel	X	X	X	X	X	X	X	X
11	140X226	Right Evaporator Support	X	X	X	X	X	X	X	X
12	112-227	Filter Sensor Bracket	X	X	X	X	X	X	X	X
13	142-055	Condenser Blank Off Plate	X	X	X	X	X	X	X	X
14	520-304	Condenser Partition Assembly	X	X	X	X	X	X	X	X
15	124-031	Fan Shroud Left Side	X	X	X	X	X	X	X	X
15	124-032	Fan Shroud Back	X	X	X	X	X	X	X	X
15	124-033	Fan Shroud Right Side	X	X	X	X	X	X	X	X
16	140-228	Wire Shield	X	X	X	X	X	X	X	X
17	140X229	Right Condenser Coil Support	X	X	X	X	X	X	X	X
18	134-164-* (1)	Side Trim	4	4	4	4	4	4	4	4
19	500-329-* (1)	Right Side Assembly	X	X	X	X	X	X	X	X
20	140-227	Subcooling Loop Hold Down	2	2	2	2	2	2	2	2
21	123-094	Condenser Drain Pan Assembly	X	X	X	X	X	X	X	X
22	527-268	Lower Base Assembly	X	X	X	X	X	X	X	X
23	103-415	Pile Seal Offset	X	X	X	X	X	X	X	X
24	112-226	Water Sensor Bracket	X	X	X	X	X	X	X	X
25	134-152	Base Shield	X	X	X	X	X	X	X	X
26	140-225	Lower Roller Support	X	X	X	X	X	X	X	X
27		Control Panel Components	X	X	X	X	X	X	X	X
28	132-142	Control Panel Door	X	X	X	X	X	X	X	X
29	534-155	Base Trim Assembly	X	X	X	X	X	X	X	X
30	140-230	Drain Pan Support	X	X	X	X	X	X	X	X
31	552-271-* (1)	Condenser Door Assembly	X	X	X	X	X	X	X	X
32	140Y229	Left Condenser Coil Support	X	X	X	X	X	X	X	X
33	142-155	Condenser Blank Off Plate	X	X	X	X	X	X	X	X
34	552-266-* (1)	Filter Door Assembly	X	X	X	X	X	X	X	X
35	152-265-* (1)	Circuit Breaker Door	X	X	X	X	X	X	X	X
36	112-228	Door Switch Bracket	X	X	X	X	X	X	X	X
37		Pull Disconnect Door Inner		X		X		X		X
37	132-143	Circuit Breaker Door Inner	X		X		X		X	
38	130-114	Filter Tray	X	X	X	X	X	X	X	X
39	552-270-* (1)	Blower Door Assembly	X	X	X	X	X	X	X	X
40	130-118	Filter Frame	X	X	X	X	X	X	X	X
41	140Y226	Left Evaporator Support	X	X	X	X	X	X	X	X
42	116-192	Relay Control Panel	X	X	X	X	X	X	X	X
43	500-330-* (1)	Left Side Assembly	X	X	X	X	X	X	X	X
44	113-142	Expansion Valve Mounting Plate	X	X	X	X	X	X	X	X
45	134-165-* (1)	Base Trim Extension	2	2	2	2	2	2	2	2
46	104-981	Filter Frame Back	X	X	X	X	X	X	X	X
47		Pull Disconnect Assembly		X		X		X		X
47		Circuit Breaker Box Assembly	X		X		X		X	
48	112-229	Heatstrip Bracket	X	X	X	X	X	X	X	X
49	112-234	Mounting Bracket	2	2	2	2	2	2	2	2

(1) Exterior cabinet parts are manufactured with various color options. To insure that you receive the proper color, you must include the complete models and serial number of the unit for which parts are being ordered.

FUNCTIONAL COMPONENTS

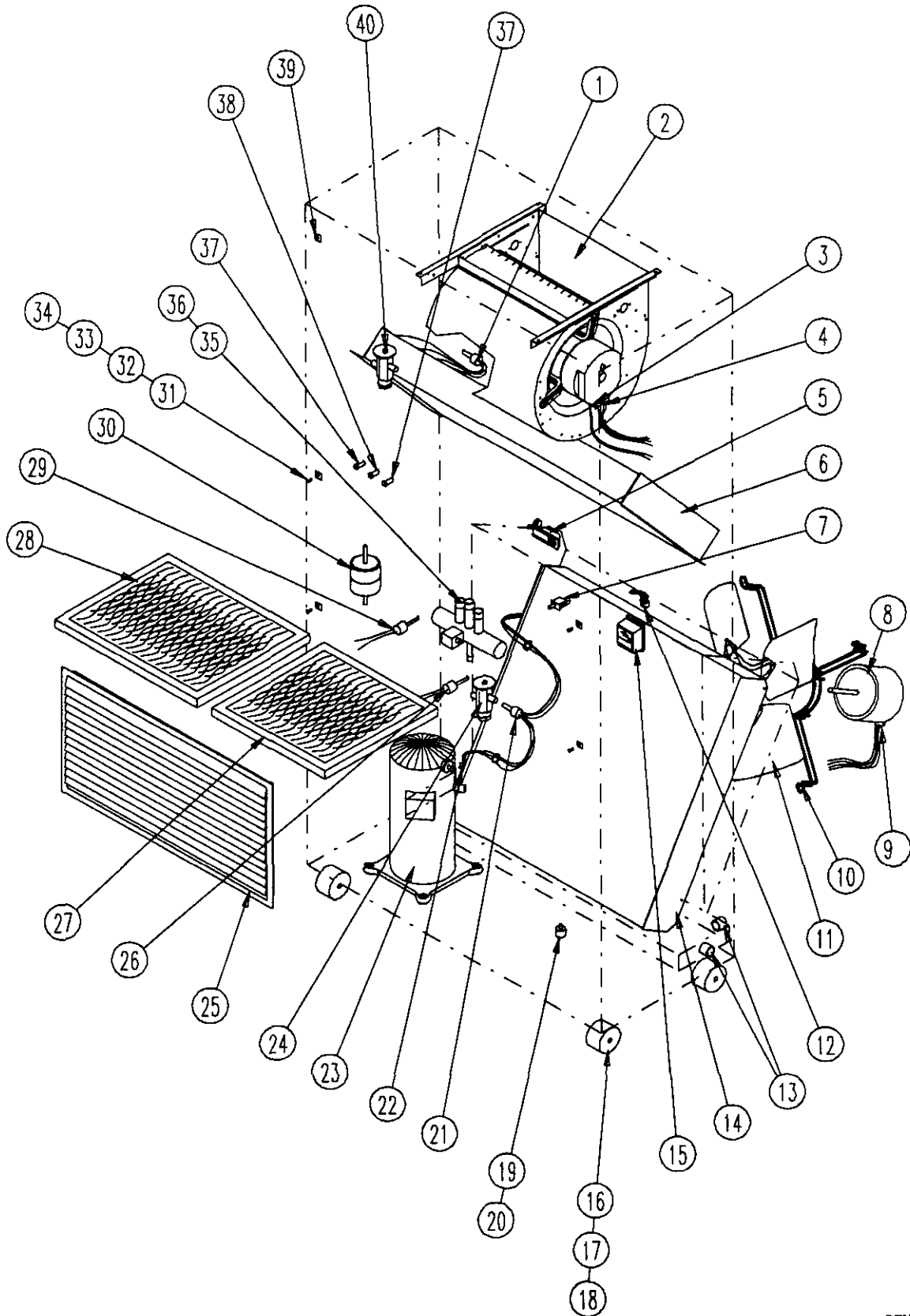

SEXP-240

FUNCTIONAL COMPONENTS

Drawing			QH241-A	QH241-B	QH241-C	QH301-A	QH301-B	QH301-C	QH361-A	QH361-B	QH361-C	QH421-A	QH421-B	QH421-C
No.	Part No.	Description												
1	800-0247	Distributor Cooling	X	X	X	X	X	X	X	X	X	X	X	X
1	800-0248	Distributor Cooling												
2	900-225-001	Blower Assembly	X	X	X									
2	900-225-002	Blower Assembly				X	X	X						
2	900-225-003	Blower Assembly							X	X	X	X	X	X
3	3000-1046	Wire Harness	X	X	X	X	X	X	X	X	X	X	X	X
4	3000-1043	Wire Harness	X	X	X	X	X	X	X	X	X	X	X	X
5	1171-036	Keylatch/Circuit Breaker Door	X	X	X	X	X	X	X	X				
6	5060-089	Evaporator Coil	X	X	X	X	X	X						
6	5060-090	Evaporator Coil							X	X	X	X	X	X
7	8406-085	Door Switch	X	X	X	X	X	X	X	X	X	X	X	X
8	8103-021	Motor	X	X	X	X	X	X	X	X	X	X	X	X
9	3000-1049	Wire Harness	X	X	X	X	X	X	X	X	X	X	X	X
10	8200-001	Motor Mount	X	X	X	X	X	X	X	X	X	X	X	X
11	5151-050	Fan Blade	X	X	X	X	X	X	X	X	X	X	X	X
12	300-1047	Wire Harness	X	X	X	X	X	X	X	X	X	X	X	X
13	6094-003	Drain Fitting	X	X	X	X	X	X	X	X	X	X	X	X
14	5051-095	Condenser Coil	X	X	X	X	X	X						
14	5051-096	Condenser Coil							X	X	X	X	X	X
15	8301-011	Dirty Filter Switch	X	X	X	X	X	X	X	X	X	X	X	X
16	1171-035	Wheel	4	4	4	4	4	4	4	4	4	4	4	4
17	1012-129	Bolt - Shoulder	4	4	4	4	4	4	4	4	4	4	4	4
18	1012-224	Nut - Locking	4	4	4	4	4	4	4	4	4	4	4	4
19	8406-083	Water Level Switch	X	X	X	X	X	X	X	X	X	X	X	X
20	1012-316	Nut - Water Level Switch	X	X	X	X	X	X	X	X	X	X	X	X
21	800-0249	Distributor - Heating	X	X	X	X	X	X						
21	800-0250	Distributor - Heating							X	X	X	X	X	X
22	910-1257	Defrost Sensor	X	X	X	X	X	X	X	X	X	X	X	X
23	8000-171	Compressor	X											
23	8000-201	Compressor		X										
23	8000-202	Compressor			X									
23	8000-172	Compressor				X								
23	8000-203	Compressor					X							
23	8000-204	Compressor						X						
23	8000-175	Compressor							X					
23	8000-163	Compressor								X				
23	8000-164	Compressor									X			
23	8000-177	Compressor										X		
23	8000-205	Compressor											X	
23	8000-206	Compressor												X
24	5651-137	TXV Heating	X	X	X									
24	5651-138	TXV Heating				X	X	X						
24	5651-102	TXV Heating							X	X	X	X	X	X
25	7051-034	Return Air Grille	X	X	X	X	X	X	X	X	X	X	X	X
26	8406-055	High Pressure Control	X	X	X	X	X	X	X	X	X	X	X	X
27	7004-009	Air Filter	X	X	X	X	X	X	X	X	X	X	X	X
28	7004-010	Air Filter	X	X	X	X	X	X	X	X	X	X	X	X
29	8406-061	Low Pressure Control	X	X	X	X	X	X	X	X	X	X	X	X
30	5201-009	Filter/Drier	X	X	X	X	X	X	X	X	X	X	X	X
<i>Continued on Page 5</i>														

FUNCTIONAL COMPONENTS

Drawing			QH241-A	QH241-B	QH241-C	QH301-A	QH301-B	QH301-C	QH361-A	QH361-B	QH361-C	QH421-A	QH421-B	QH421-C
No.	Part No.	Description												
31	1171-038	Cupped Washer Black	4	4	4	4	4	4	4	4	4	4	4	4
32	1171-024	Retainer Clip	4	4	4	4	4	4	4	4	4	4	4	4
33	1171-040	1/4 Turn Screw	4	4	4	4	4	4	4	4	4	4	4	4
34	1171-037	Clip Receptacle	4	4	4	4	4	4	4	4	4	4	4	4
35	5650-020	Reversing Valve	X	X	X									
35	5650-021	Reversing Valve				X	X	X						
35	5650-025	Reversing Valve							X	X	X	X	X	X
36	5650-022	Solenoid Coil	X	X	X	X	X	X	X	X	X	X	X	X
37	8611-094	Indicator Light - Red	2	2	2	2	2	2	2	2	2	2	2	2
38	8611-095	Indicator Light - Yellow	X	X	X	X	X	X	X	X	X	X	X	X
39	1012-315	"U" Clip Fastener	12	12	12	12	12	12	12	12	12	12	12	12
40	5651-137	TXV Cooling	X	X	X									
40	5651-138	TXV Cooling				X	X	X						
40	5651-102	TXV Cooling							X	X	X	X	X	X
	4100-101	Wiring Diagram	X			X			X			X		
	4100-201	Wiring Diagram		X			X			X			X	
	4100-301	Wiring Diagram			X			X			X			X

This page has been left blank intentionally.

CONTROL PANEL COMPONENTS

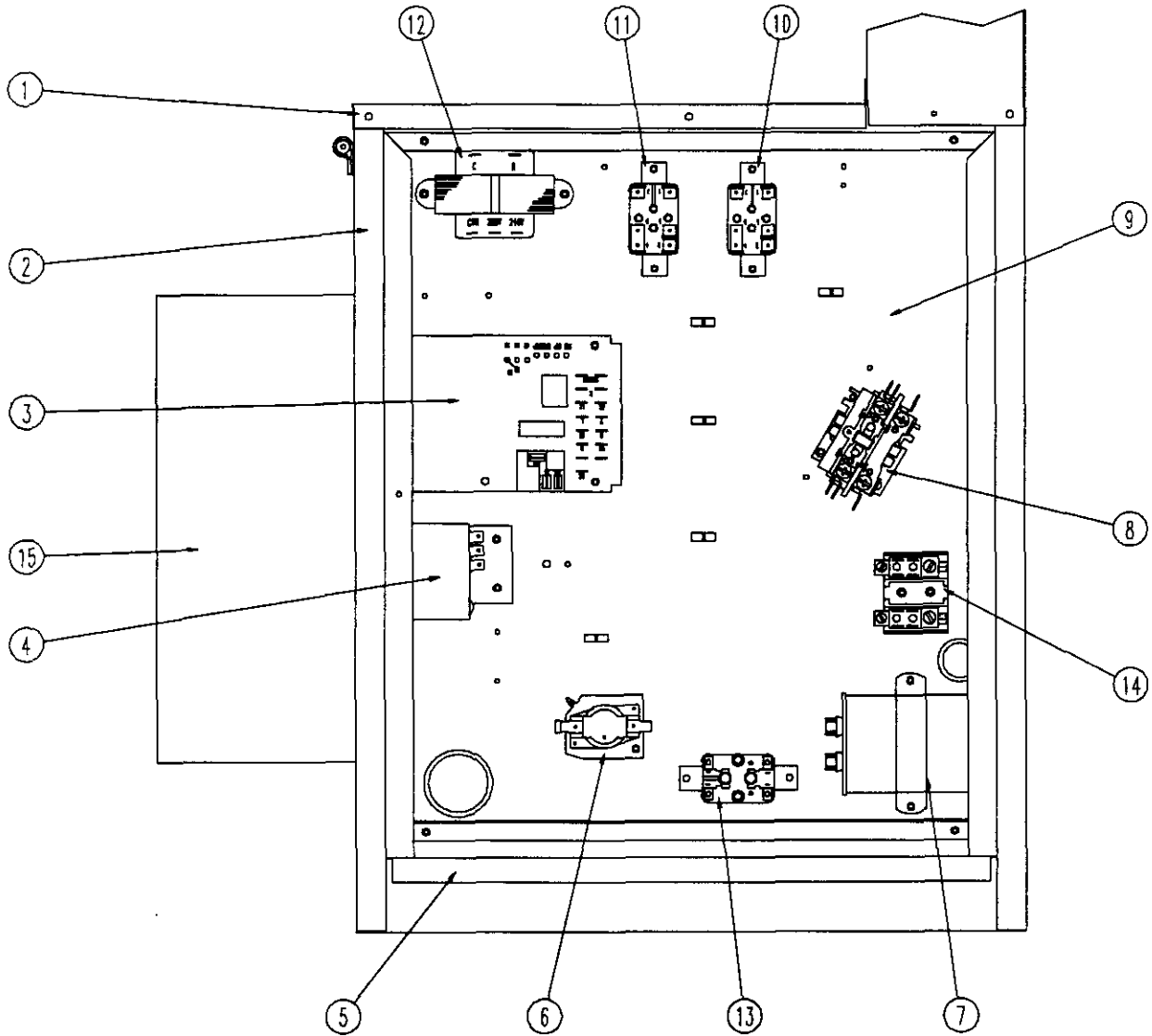

SEXP-246

CONTROL PANEL COMPONENTS

Drawing			QH241-A	QH241-B	QH241-C	QH301-A	QH301-B	QH301-C	QH361-A	QH361-B	QH361-C	QH421-A	QH421-B	QH421-C
No.	Part No.	Description												
1	116-186	Control Panel Top	X	X	X	X	X	X	X	X	X	X	X	X
2	116-184	Control Panel	X	X	X	X	X	X	X	X	X	X	X	X
3	8201-069	Heat Pump Control	X	X	X	X	X	X	X	X	X	X	X	X
4	8408-034	Outdoor Thermostat Condenser Motor Two Speed	X	X	X	X	X	X	X	X	X	X	X	X
5	126-266	Control Panel Base	X	X	X	X	X	X	X	X	X	X	X	X
6	8210-065	Low Pressure Bypass TDR	X	X	X	X	X	X	X	X	X	X	X	X
7	8552-002	Capacitor		X	X		X	X		X	X		X	X
7	8552-050	Capacitor	X											
7	8552-052	Capacitor				X								
7	8552-063	Capacitor							X					
7	8552-062	Capacitor										X		
8	8401-007	Contactor	X			X			X			X		
8	8401-002	Contactor		X	X		X	X		X	X		X	X
9	116-186	Control Panel Mounting Plate	X	X	X	X	X	X	X	X	X	X	X	X
10	8201-062	Relay SPDT Pilot Duty	X	X	X	X	X	X	X	X	X	X	X	X
11	8201-009	Blower Relay	X	X	X	X	X	X	X	X	X	X	X	X
12	8407-035	Transformer	X	X	X	X	X	X	X	X	X	X	X	X
13	8201-008	Fan Relay			X			X			X			X
14	8607-013	Terminal Block Two Terminals			X			X			X			X
15	8407-003	Transformer Stepdown			X			X			X			X

BLOWER ASSEMBLY COMPONENTS

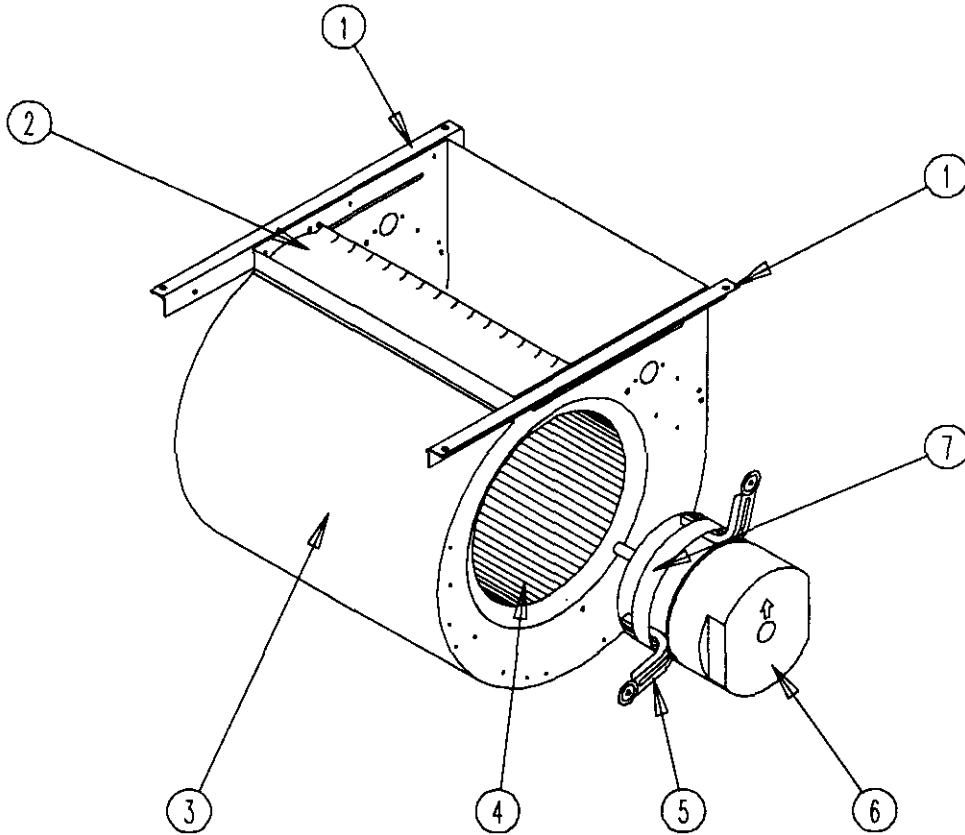

BLOWER ASSEMBLY COMPONENTS

Drawing No.	Part No.	Description	900-225-001	900-225-002	900-225-003
1	104-980	Blower Angle	2	2	2
2	144-131	Diffuser	X	X	X
3	151-110	Blower Housing	X	X	X
4	5152-061	Blower Wheel	X	X	X
5	8200-034	Motor Mount Arm	3	3	3
6	8106-035-0003	Motor	X		
6	8106-035-0004	Motor		X	
6	8106-035-0005	Motor			X
7	8200-033	Motor Mount Band	X	X	X

OPTIONAL CLIMATE CONTROLS

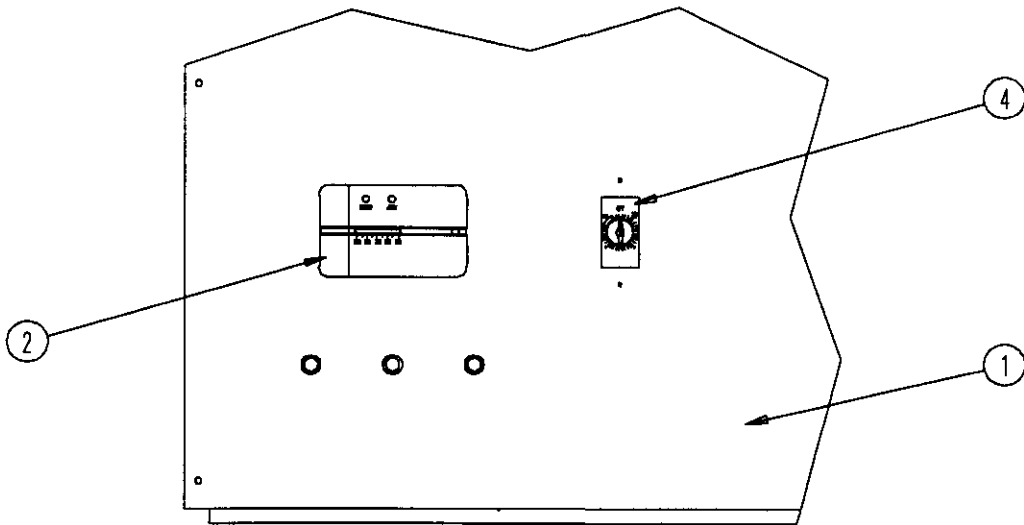
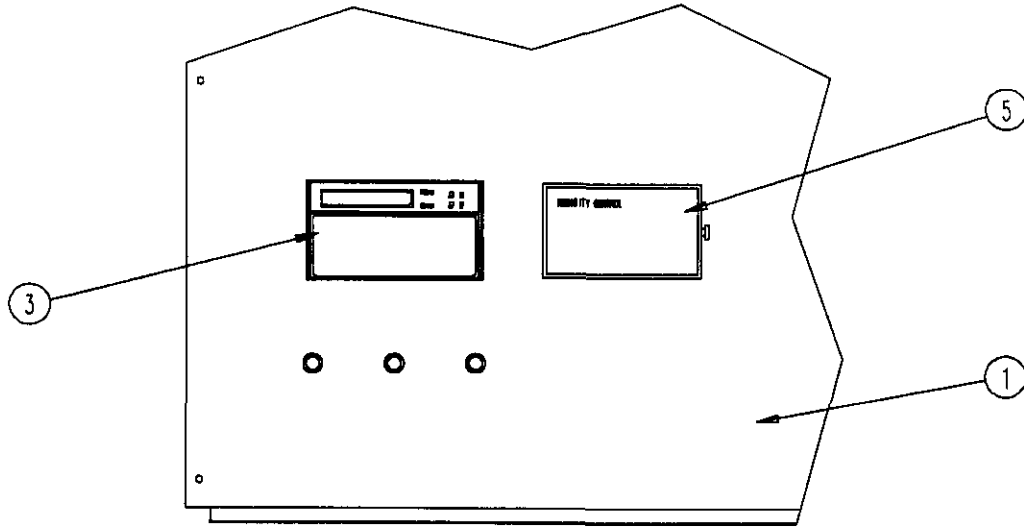

OPTIONAL CLIMATE CONTROLS

OPTIONAL CLIMATE CONTROL REPLACEMENT PARTS –

See table below to determine which Climate Control Option is installed:

Drawing No.	Part No.	Description	Option X	Option A	Option B	Option C	Option D	Option E
1	552-270-6	Blower Door	X					
1	552-268-6	Blower Door		X			X	
1	552-269-6	Blower Door			X	X		
1	552-272-6	Blower Door						X
2	8403-037	Electronic/Non-Programmable/Manual Change Over		X	X	X		
3	8403-034	Electronic/Programmable/Manual/Auto Change Over					X	X
4	8612-016	Timer 4 Hours			X			
4	8612-015	Timer 6 Hours				X		
5	8403-038	Humidistat						X

CLIMATE CONTROL OPTION NOMENCLATURE AS SHOWN IN UNIT MODEL NUMBER

QH 361 - A 09 X X X X X X

- X – None
- A – Electronic, non-programmable, manual change over
- B – Electronic, non-programmable, manual change over, 4 hour timer
- C – Electronic, non-programmable, manual change over, 6 hour timer
- D – Electronic, programmable, manual/auto change over
- E – Electronic, programmable, manual/auto change over, humidistat

OPTIONAL HEATER COMPONENTS

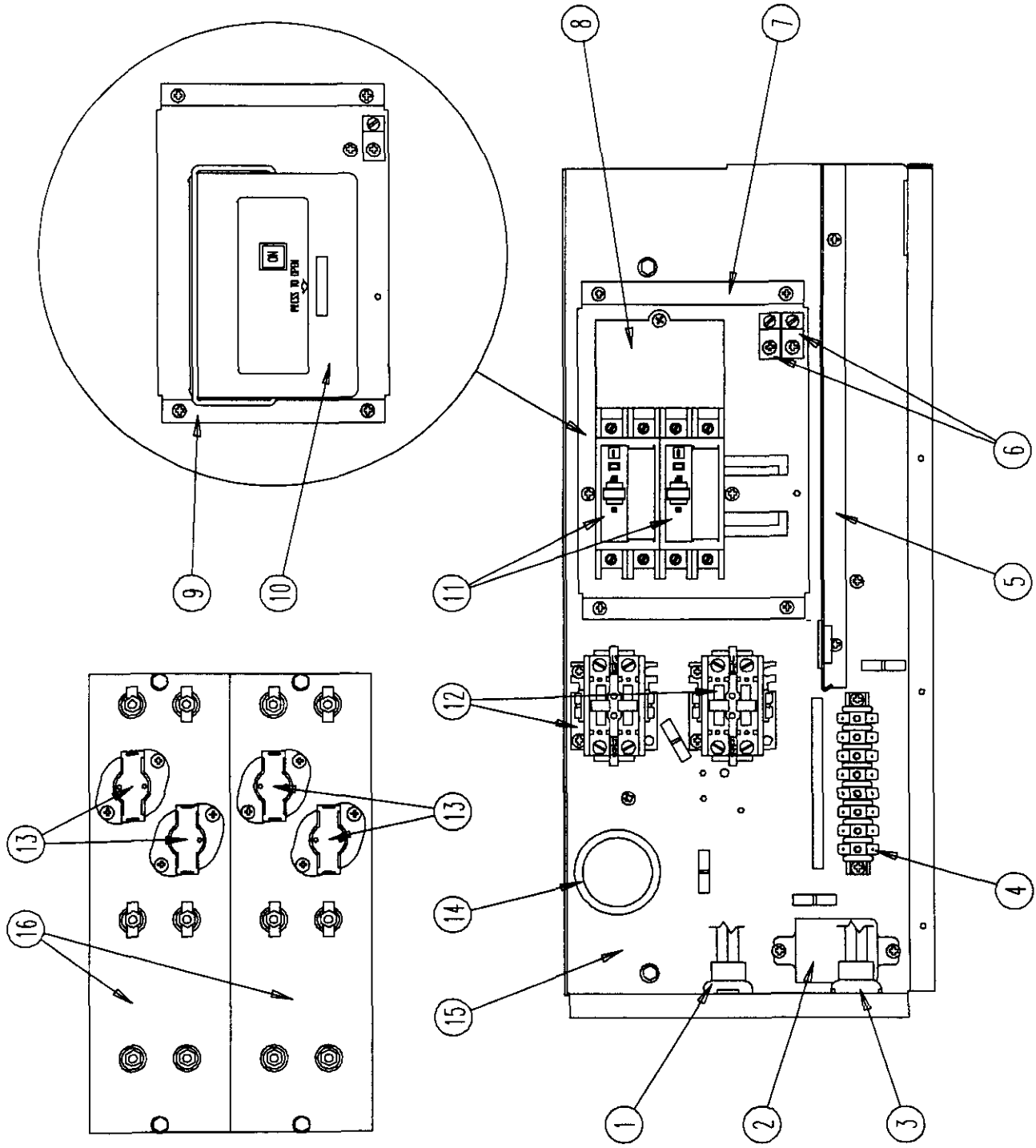

SEXP-244

OPTIONAL HEATER COMPONENTS

Drawing			QH241-A0Z	QH301-A0Z	QH241-A05	QH301-A05	QH241-A10	QH301-A10	QH241-B0Z	QH301-B0Z	QH241-B06	QH301-B06	QH241-B09	QH301-B09	QH301-B12
No.	Part No.	Description													
1	3000-1044	Wire Set	X	X	X	X	X	X	X	X	X	X	X	X	X
2		Relay													
3	3000-1043	Wire Set	X	X	X	X	X	X	X	X	X	X	X	X	X
4	8607-022	Terminal Block	X	X	X	X	X	X	X	X	X	X	X	X	X
5	116-190	Box Partition	X	X	X	X	X	X	X	X	X	X	X	X	X
6	8611-006	Ground Lug	X	X	X	X	X	X	X	X	X	X	X	X	X
7	126-267	Circuit Breaker Base	X	X	X	X	X	X	X	X	X	X	X	X	X
8	8615-047	Jumper Bar Base				X									
11	8615-037	Circuit Breaker 30A 2-Pole	X		X										
11	8615-040	Circuit Breaker 50A 2-Pole		X	X										
11	8615-054	Circuit Breaker 20A 2-Pole					X								
11	8615-042	Circuit Breaker 35A 3-Pole								X					
11	8615-051	Circuit Breaker 25A 3-Pole							X						
11	8615-043	Circuit Breaker 40A 3-Pole										X			
11	8615-044	Circuit Breaker 45A 3-Pole											X		
11	8615-046	Circuit Breaker 60A 3-Pole													X
12	8401-006	Contactors 2-Pole 20A		X	X						X	X	X	X	
14	8611-026	Snap Bushings 1-3/4	X	X	X	X	X	X	X	X	X	X	X	X	X
15	116-189	Box Circuit/Pull Disconnect	X	X	X	X	X	X	X	X	X	X	X	X	X
16	8604-103	Heat Strip 5 KW		X											
16	8604-104	Heat Strip 10 KW				X									
16	8604-105	Heat Strip 6 KW 3 PH								X	X				X
16	8604-106	Heat Strip 9 KW 3 PH											X		
	4101-100	Wiring Diagram	X												
	4101-101	Wiring Diagram		X											
	4101-102	Wiring Diagram			X										
	4101-103	Wiring Diagram					X								
	4101-200	Wiring Diagram						X							
	4101-201	Wiring Diagram							X	X			X		
	4101-203	Wiring Diagram													X

OPTIONAL HEATER COMPONENTS

Drawing			QH241-C0Z	QH301-C0Z	QH241-C06	QH301-C06	QH241-C09	QH301-C09	QH301-C12	QH361-A0Z	QH421-A0Z	QH361-A05	QH421-A05	QH361-A10	QH421-A10	QH361-A15	QH421-A15
No.	Part No.	Description															
1	3000-1044	Wire Set	X	X	X	X	X	X	X	X	X	X	X	X	X	X	X
2	8201-048	Relay															X
3	3000-1043	Wire Set	X	X	X	X	X	X	X	X	X	X	X	X	X	X	X
4	8607-022	Terminal Block	X	X	X	X	X	X	X	X	X	X	X	X	X	X	X
5	116-190	Box Partition	X	X	X	X	X	X	X	X	X	X	X	X	X	X	X
6	8611-006	Ground Lug	X	X	X	X	X	X	X	X	X	X	X	X	X	X	X
7	126-267	Circuit Breaker Base	X	X	X	X	X	X	X	X	X	X	X	X	X	X	X
8	8615-047	Jumper Bar Base												X	X		X
9	126-269	Pull Disconnect Base	X	X	X	X	X	X									
10	8615-053	Pul Disconnect	X	X	X	X	X	X									
11	8615-039	Circuit Breaker 45A 2-Pole								X							
11	8615-040	Circuit Breaker 50A 2-Pole									X			X			X
11	8615-041	Circuit Breaker 60A 2-Pole										X		X			X
11	8615-044	Circuit Breaker 40A 2-Pole												X			X
12	8401-006	Contactor 2-Pole 20A		X	X	X	X	X				X		X			X
13	8402-100	Limits		X	X	X	X	X	X			X		X			X
14	8611-026	Snap Bushings 1-3/4	X	X	X	X	X	X	X	X	X	X	X	X	X	X	X
15	116-189	Box Circuit/Pull Disconnect	X	X	X	X	X	X	X	X	X	X	X	X	X	X	X
16	8604-103	Heat Strip 5 KW										X					X
16	8604-104	Heat Strip 10 KW												X			X
16	8604-105	Heat Strip 6 KW 480 V		X				X									
16	8604-106	Heat Strip 9 KW 480 V			X												
	4101-100	Wiring Diagram								X	X						
	4101-101	Wiring Diagram										X					
	4101-102	Wiring Diagram												X			
	4101-103	Wiring Diagram														X	
	4101-300	Wiring Diagram	X														
	4101-301	Wiring Diagram		X	X												
	4101-303	Wiring Diagram						X									X

OPTIONAL HEATER COMPONENTS

Drawing No.	Part No.	Description	QH361-B0Z	QH421-B0Z	QH361-B06	QH421-B06	QH361-B09	QH421-B09	QH361-B15	QH421-B15	QH361-C0Z	QH421-C0Z	QH361-C06	QH421-C06	QH361-C09	QH421-C09	QH361-C15	QH421-C15	
1	3000-1044	Wire Set	X		X		X		X		X		X		X		X		X
2	8401-048	Relay							X										X
3	3000-1043	Wire Set	X		X		X		X		X		X		X		X		X
4	8607-022	Terminal Block	X		X		X		X		X		X		X		X		X
5	116-190	Box Partition	X		X		X		X		X		X		X		X		X
6	8611-006	Ground Lug	X		X		X		X		X		X		X		X		X
7	126-267	Circuit Breaker Base	X		X		X		X										
8	8615-047	Jumper Bar Base																	
9	126-269	Pull Disconnect Base									X		X		X		X		X
10	8615-053	Pul Disconnect									X		X		X		X		X
11	8615-039	Circuit Breaker 45A 3-Pole			X														
11	8615-040	Circuit Breaker 50A 3-Pole					X												
11	8615-041	Circuit Breaker 60A 3-Pole							X										
11	8615-044	Circuit Breaker 30A 3-Pole	X																X
12	8401-006	Contactora 2-Pole 20A			X		X		X					X		X		X	X
12	8401-002	Contactora 3-Pole 25A																	
13	8402-100	Limits			X		X		X				X		X		X		X
14	8611-026	Snap Bushings 1-3/4	X		X		X		X		X		X		X		X		X
15	116-189	Box Circuit/Pull Disconnect	X		X		X		X		X		X		X		X		X
16	8604-103	Heat Strip 6 KW 3 PH			X				X										
16	8604-104	Heat Strip 9 KW 3 PH					X		X										
16	8604-105	Heat Strip 6 KW 480 V											X						X
16	8604-106	Heat Strip 9 KW 480 V													X				X
	4101-200	Wiring Diagram	X																
	4101-201	Wiring Diagram			X		X												
	4101-202	Wiring Diagram							X										
	4101-300	Wiring Diagram									X								
	4101-301	Wiring Diagram										X		X		X			
	4101-302	Wiring Diagram																	X

