

---

# Replacement Parts Manual

# Wall Mounted Package Air Conditioner

MODEL: WA371

---

## General Notes

- Revised and/or additional pages may be issued from time to time.
- A complete and current manual consists of pages shown in the following contents section.

## Important

- Contact the installing and/or local Bard distributor for all parts requirements. Make sure you have the complete model and serial number available from the unit rating plates.

## Contents

Description	Page
Cabinet Components	
♦ Exploded View .....	1
♦ Usage List .....	2
Functional Components	
♦ Exploded View .....	3
♦ Usage List .....	4
Control Panel	
♦ Exploded View .....	5
♦ Usage List .....	6
Blower Assembly	
♦ Exploded View .....	7
♦ Usage List .....	7



**BAR D MANUFACTURING COMPANY**  
Bryan, Ohio 43506

*Since 1914...Moving ahead, just as planned.*

Manual: 2110-429A  
Supersedes: 2110-429  
File: 2150-004 Tab 16  
Date: 04-08-99

---

# CABINET COMPONENTS

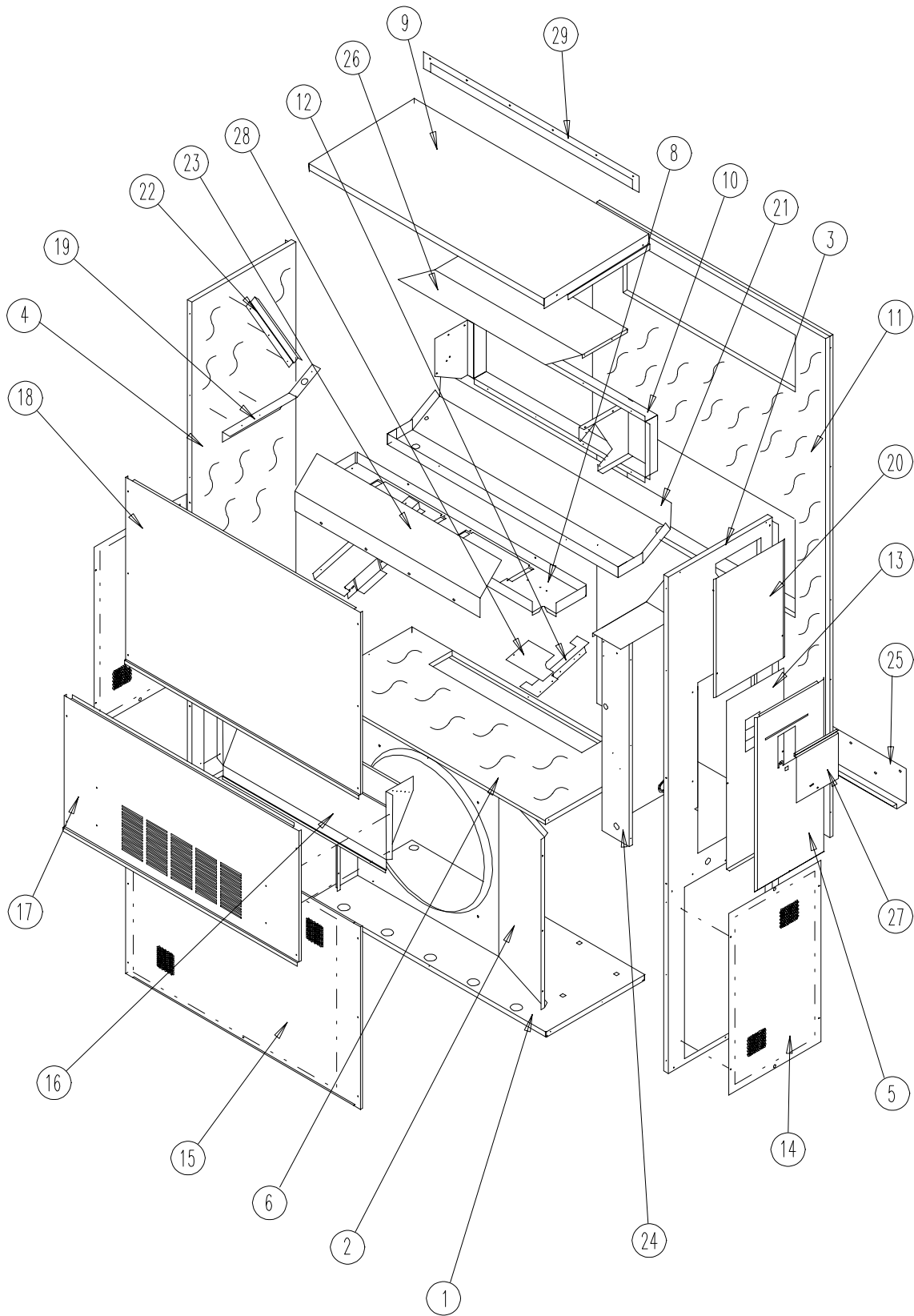

SEXP-160

# CABINET COMPONENTS

Drawing No.	Part No.	Description	WA371-A	WA371-B	WA371-C	WA371-D	WA371-E	WA371-F
1	S127-199	Lower Base	X	X	X	X	X	X
2	125-022	Fan Shroud	X	X	X	X	X	X
3	S500-228-* ①	Right Side	X	X	X	X	X	X
4	S500-229-* ①	Left Side	X	X	X	X	X	X
5	S553-109-* ①	Control Panel Cover (Outer)	X	X	X	X	X	X
6	S520X181	Condenser Partition	X	X	X	X	X	X
8	121X182	Blower Partition	X	X	X	X	X	X
9	S506-130-* ①	Top	X	X	X	X	X	X
10	S111X030	Outlet Airframe Assemble	X	X	X	X	X	X
11	S508-088	Back	X	X	X	X	X	X
12	113X195	Filter Bracket	2	2	2	2	2	2
13	S132-104	Control Panel Cover (Inner)	X	X		X	X	
13	S132-110	Control Panel Cover (Inner)			X			X
14	118-028-* ①	Side Grille	2	2	2	2	2	2
15	118-029-* ①	Condenser Grille	X	X	X	X	X	X
16	962014	Fresh Air Damper Assembly	X	X	X	X	X	X
17	S552-206-* ①	Service Door	X	X	X	X	X	X
18	S514-072-* ①	Upper Front	X	X	X	X	X	X
19	105X850	Left Side Support	X	X	X	X	X	X
20	S143-034-* ①	Right Side Cover Plate (Outer)	X	X	X	X	X	X
21	S123-078	Drain Pan	X	X	X	X	X	X
22	147-044	Evaporator Support	X	X	X	X	X	X
23	135-124	Air Baffle	X	X	X	X	X	X
24	Control Panel Assy.	See Control Panel Assembly Drawing and Parts List	X	X	X	X	X	X
25	113-140	Bottom Mounting Bracket	1	1	1	1	1	1
26	135X123	Heat Shield	X	X	X	X	X	X
27	S153-218-* ①	Disconnect Access Door	X	X	X	X	X	X
28	137-259	Fill Plate	X	X	X	X	X	X
29	113-149-* ①	Top Rain Flashing	X	X	X	X	X	X

① *NOTE: Exterior cabinet parts are manufactured with various paint color options. To insure that you receive the proper paint color, you must include the complete model and serial number of the unit for which cabinet parts are being ordered.*

# FUNCTIONAL COMPONENTS

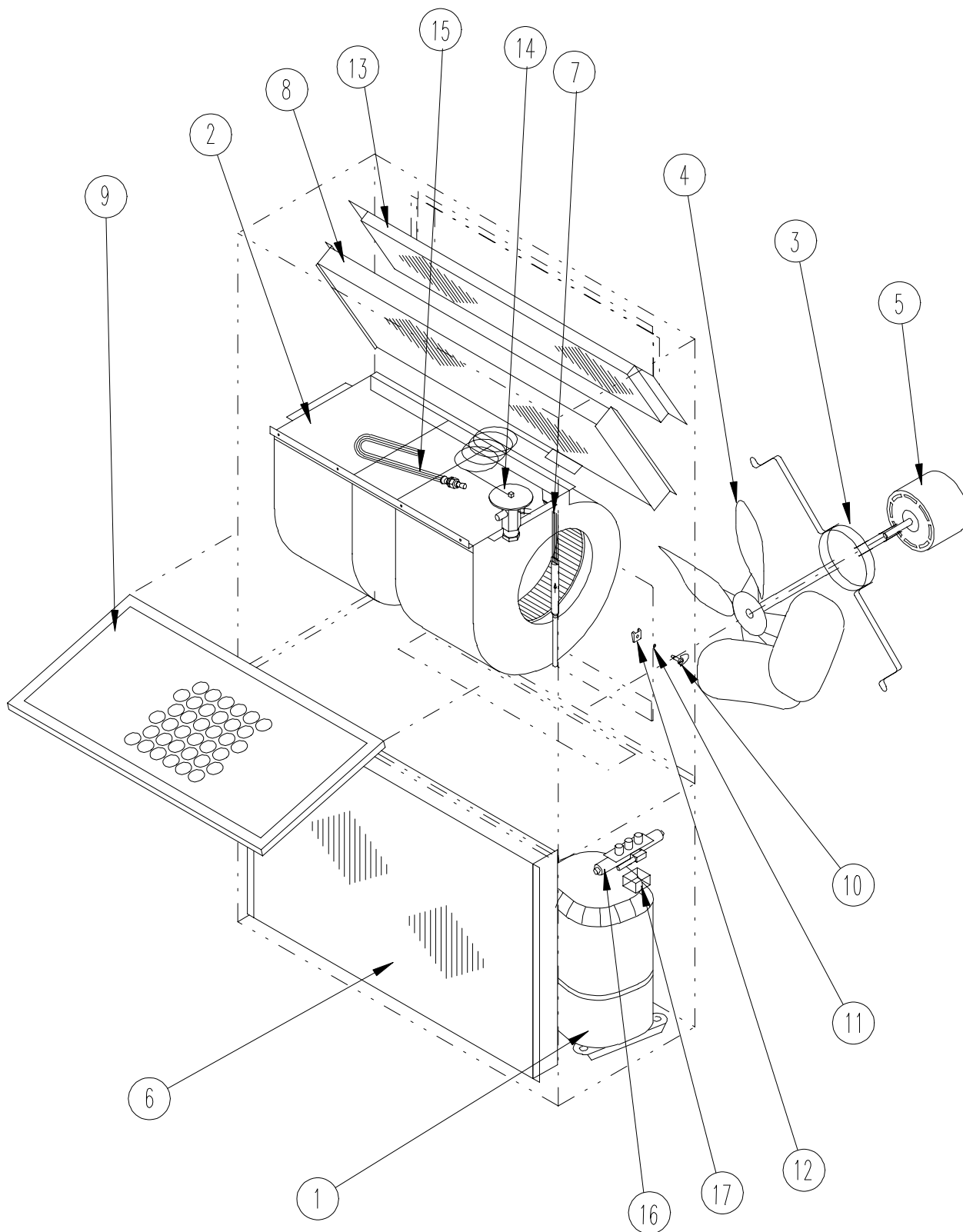

SEXP-162

## FUNCTIONAL COMPONENTS

Drawing			WA371-A	WA371-B	WA371-C	WA371-D	WA371-E	WA371-F
No.	Part No.	Description						
1	8000-225	Compressor	X					
1	8000-214	Compressor		X			X	
1	8000-217	Compressor			X			X
1	8000-226	Compressor				X		
2	S900-231	Blower Assembly	X	X		X	X	X
2	S900-232	Blower Assembly			X			
3	8200-001	Fan Motor Mount	X	X	X	X	X	X
4	5151-045	Fan Blade	X	X	X	X	X	X
5	8103-013	Condenser Motor	X	X		X	X	X
5	8103-020	Condenser Motor			X			
6	5051-066	Condenser Coil	X	X	X	X	X	X
7	800-0185	Cooling Capillary Assembly	X	X	X	X	X	X
8	5060-064	Evaporator Coil	X	X	X	X	X	X
9	7004-019	Air Filter 1" Throw Away	X	X	X	X	X	X
9	7003-031	Air Filter 1" Washable ①	X	X	X	X	X	X
9	7004-026	Air Filter 2" Pleated ①	X	X	X	X	X	X
10	1171-022	1/4" Turn Fastener	X	X	X	X	X	X
11	1171-024	1/4" Turn Retainer	X	X	X	X	X	X
12	1171-023	1/4" Receptacle	X	X	X	X	X	X
NS	1804-0106	High Pressure Switch (Flare)	X	X	X	X	X	X
NS	1804-0107	Low Pressure Switch (Flare) ①	X	X	X	X	X	X
NS	CMA-6	Low Ambient Control (Flare) ①	X	X	X	X	X	X

NS = Not Shown

① = Optional

# CONTROL PANEL

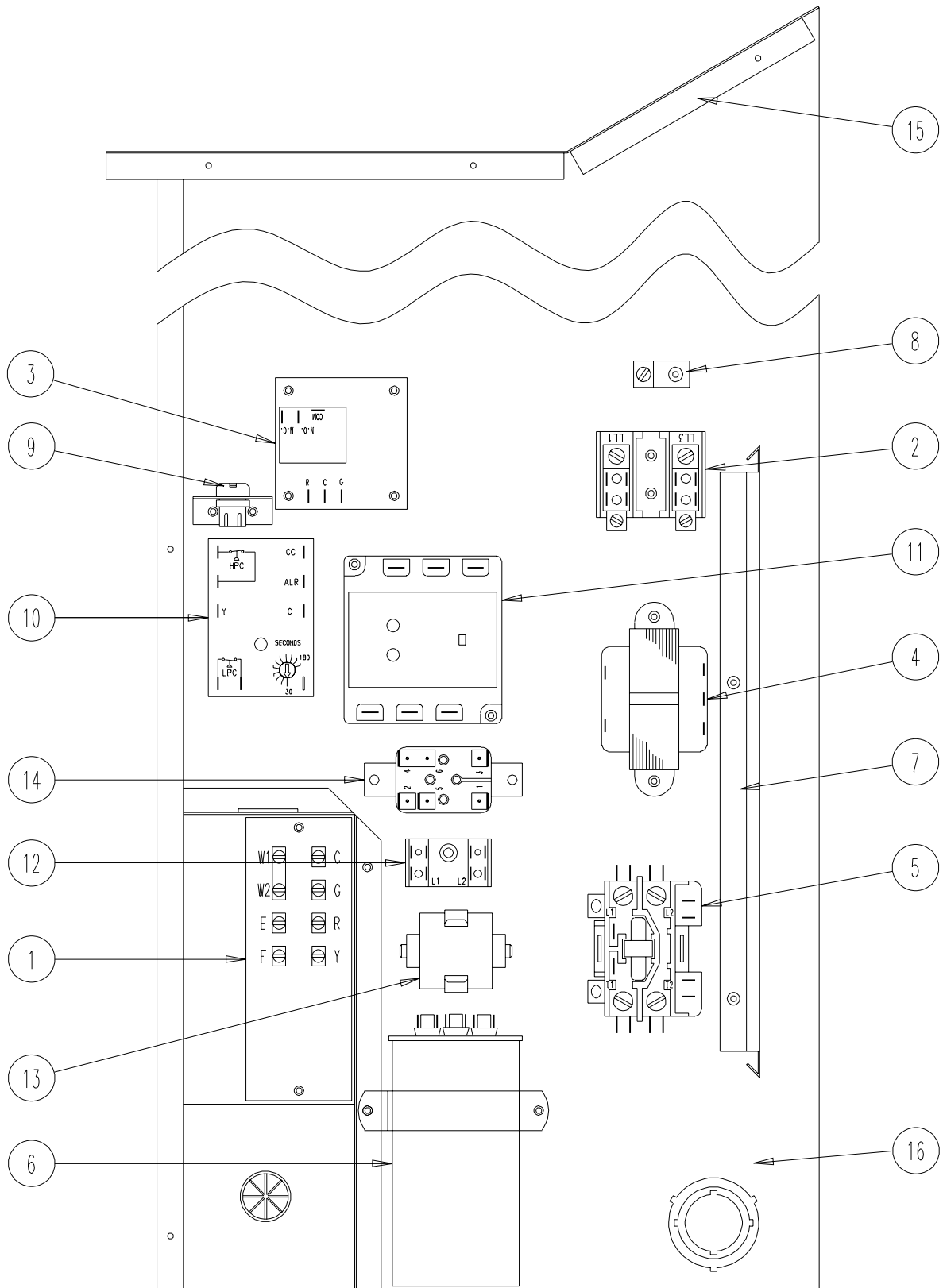

SEXP-291

# CONTROL PANEL

Drawing			WA371-A	WA371-B	WA371-C	WA371-D	WA371-E	WA371-F
No.	Part No.	Description						
1	8607-020	Low Voltage Terminal Strip	X	X	X	X	X	X
2	8607-013	Terminal Block 2 Pole	X			X		2
2	8607-014	Terminal Block 3 Pole		X	X		X	
2	8607-015	Phenolic Insulator			X			2
3	8201-056	Blower Control	X	X		X	X	X
3	8201-032	Blower Relay			X			
4	8407-034	Transformer	X	X		X	X	X
4	8407-042	Transformer			X			
5	8401-007	Compressor Contactor	X			X		
5	8401-002	Compressor Contactor		X	X		X	X
6	8552-051	Compressor Capacitor	X			X		
6	8552-002	Outdoor Motor Capacitor		X	X		X	X
7	135-122	Wire Shield	X	X	X	X	X	X
8	8611-006	Ground Terminal	X	X	X	X	X	X
9	3000-968	6 Pin Connector	X	X	X	X	X	X
10	8201-087	Compressor Control Module	X	X	X	X	X	X
11	8201-071	Phase Monitor		X	X		X	X
12	8607-017	Terminal Block (Optional) (Shown)	X	X	X	X	X	X
13	8551-005	Start Device (PTCR) (Optional)	X			X		
14	8201-062	Alarm Relay (Optional)	X	X	X	X	X	X
15	117-137	Control Panel Top	X	X	X	X	X	X
16	117-123	Control Panel	X	X	X	X	X	X
NS	4095-128	Wiring Diagram	X			X		
NS	4095-227	Wiring Diagram		X			X	
NS	4095-318	Wiring Diagram				X		
NS	4095-620	Wiring Diagram						X

NS = Not Shown

# BLOWER ASSEMBLY

Drawing			900-231	900-232
No.	Part No.	Description		
1	151-111	Housing	2	2
2	144-174	Cutoff	2	2
3	8105-029	Blower Motor (230/208)	X	
3	8105-033	Blower Motor (460)		X
4	8552-002	Capacitor	X	X
5	8200-031	Motor Mount	X	X
6	5451-011	Grommets	6	6
7	105-870	Back Brace	X	X
8	104-868	Side Angle	4	4
9	103-401	Front Brace	X	X
10	5152-090	Wheel CW	X	X
11	5152-091	Wheel CCW	X	X

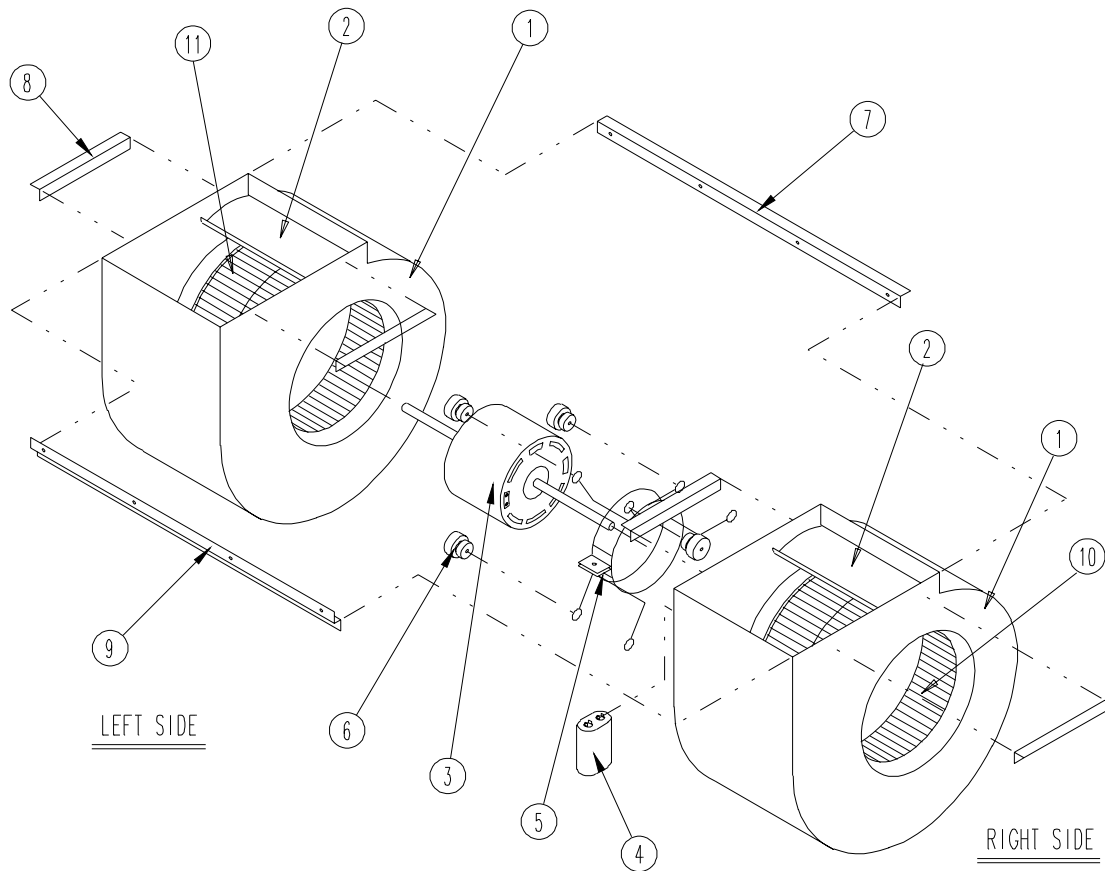

SEXP-295