Replacement Parts Manual

Wall Mounted Package Air Conditioner

MODEL: WA701, WA721

General Notes

- Revised and/or additional pages may be issued from time to time.
- A complete and current manual consists of pages shown in the following contents section.

Important

- Contact the installing and/or local Bard distributor for all parts requirements. Make sure you have the complete model and serial number available from the unit rating plates.

Contents

Description	Page
Cabinet Components	
♦ Exploded View	1
♦ Usage List	2
Functional Components	
♦ Exploded View	3
♦ Usage List	4
Control Panel	
♦ Exploded View	5
♦ Usage List	6
Blower Assembly	
♦ Exploded View	7
♦ Usage List	7



BARD MANUFACTURING COMPANY
Bryan, Ohio 43506

Since 1914...Moving ahead, just as planned.

Manual: 2110-415F
Supersedes: 2110-415E
File: 2150-004 Tab 16
Date: 08-04-00

CABINET COMPONENTS

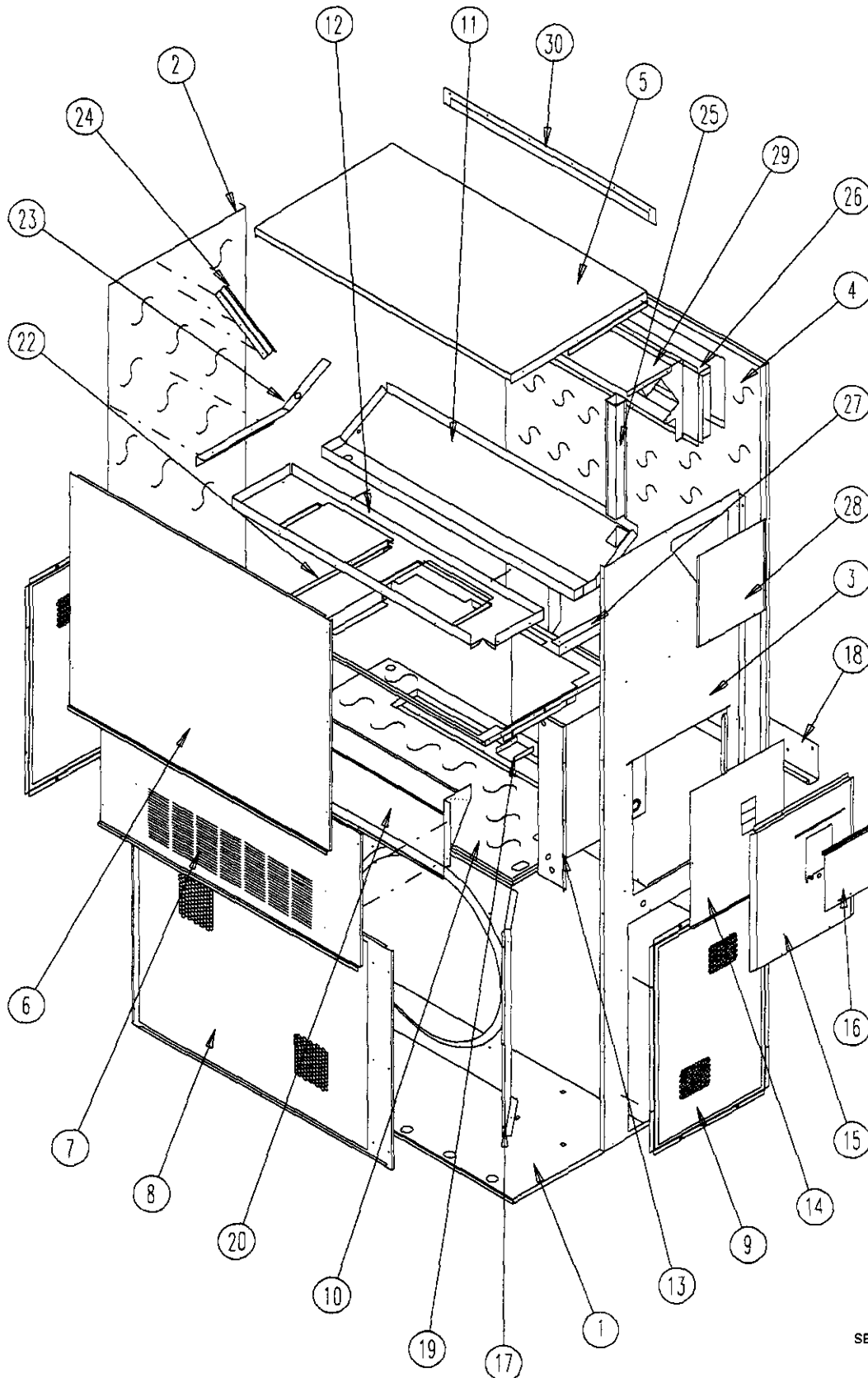

SEXP-175

CABINET COMPONENTS

Drawing No.	Part No.	Description	WA701-A	WA701-B	WA701-C,F	WA721-B
1	S127X214	Lower Base	X	X	X	X
2	S500-316-* ①	Left Side	X	X	X	X
3	S500-315-* ①	Right Side	X	X	X	X
4	S508-129	Back	X	X	X	X
5	S506-142-* ①	Top	X	X	X	X
6	S514-077-* ①	Upper Front	X	X	X	X
7	S552-224-* ①	Service Door	X	X	X	X
8	118-040-* ①	Condenser Grille	X	X	X	X
9	118-041-* ①	Side Grille	2	2	2	2
10	S520X216	Condenser Partition	X	X	X	X
11	123-083	Drain Pan	X	X	X	X
12	121X216	Blower Partition	X	X	X	X
13	Control Panel Assy.	See Control Panel Assembly Drawing and Parts List	X	X	X	X
14	S132-114	Control Panel Cover (Inner)	X	X		X
14	S132-115	Control Panel Cover (Inner)			X	
15	S533-113-* ①	Control Panel Cover (Outer)	X	X	X	X
16	S153-218-* ①	Disconnect Access Door	X	X	X	X
17	125-029	Fan Shroud	X	X	X	X
18	113-140	Bottom Mounting Bracket	X	X	X	X
19	137-209	Fill	X	X	X	X
20	BFAD-5	Fresh Air Damper Assembly	X	X	X	X
22	131X099	Filter Tray	X	X	X	X
23	105X877	Left Side Support	X	X	X	X
24	147-046-* ①	Left Evaporator Support	X	X	X	X
25	135-128	Raceway	2	2	2	2
26	111X034	Outlet Airframe Assembly	X	X	X	X
27	105X878	Right Side Support	X	X	X	X
28	S143-042-* ①	Right Side Cover Plate (Outer)	X	X	X	X
29	135X129	Heat Shield	X	X	X	X
30	113-150-* ①	Top Rain Flashing	X	X	X	X

① *NOTE: Exterior cabinet parts are manufactured with various paint color options. To insure that you receive the proper paint color, you must include the complete model and serial number of the unit for which cabinet parts are being ordered.*

FUNCTIONAL COMPONENTS

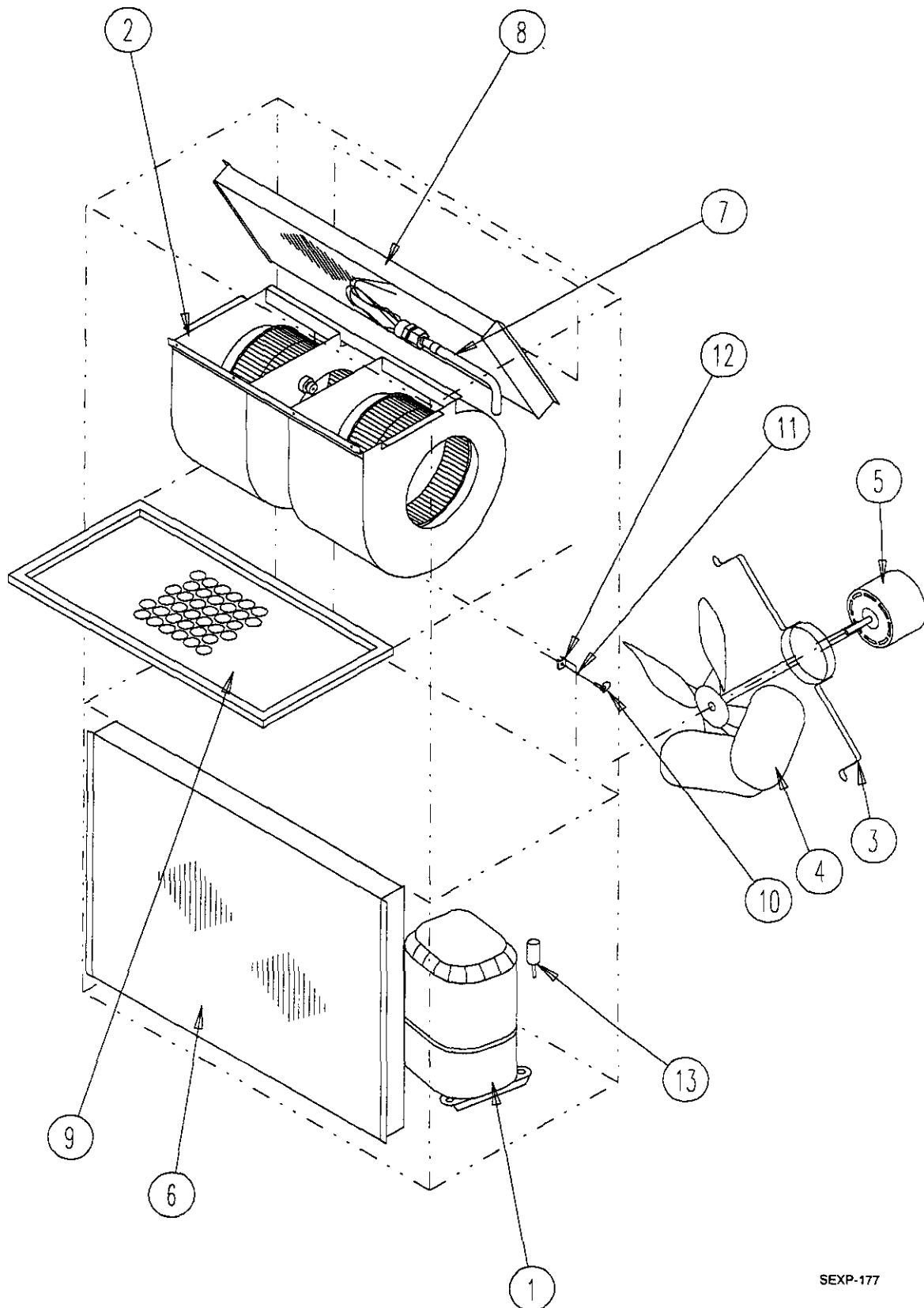

SEXP-177

FUNCTIONAL COMPONENTS

Drawing			WA701-A	WA701-B	WA701-C	WA701-F	WA721-B
No.	Part No.	Description					
1	8000-228	Compressor	X				
1	8000-187	Compressor		X			X
1	8000-190	Compressor			X	X	
2	S900-185	Blower Assembly	X	X		X	X
2	S900-186	Blower Assembly			X		
3	8200-004	Fan Motor Mount	X	X	X	X	X
4	5151-027	Fan Blade	X	X	X	X	
4	5151-030	Fan Blade					X
5	8105-039	Condenser Motor	X	X		X	
5	8105-030	Condenser Motor (460V)			X		
5	8106-016	Condenser Motor					X
6	5051-088	Condenser Coil	X	X	X	X	X
7	5651-131	Expansion Valve	X	X	X	X	X
8	5060-082	Evaporator Coil	X	X	X	X	X
9	7003-016	Air Filter 1" Throw-Away	X	X	X	X	X
9	7003-030	Air Filter 1" Washable ①	X	X	X	X	X
9	7004-027	Air Filter 2" Pleated ①	X	X	X	X	X
10	1171-022	1/4" Turn Fastener	X	X	X	X	X
11	1171-024	1/4" Turn Retainer	X	X	X	X	X
12	1171-023	1/4" Receptacle	X	X	X	X	X
NS	1804-0106	High Pressure Switch (Flare) ①	X	X	X	X	X
NS	1804-0107	Low Pressure Switch (Flare) ①	X	X	X	X	X
NS	CMA-6	Low Ambient Control (Flare) ①	X	X	X	X	X

NS = Not Shown

① = Optional

CONTROL PANEL

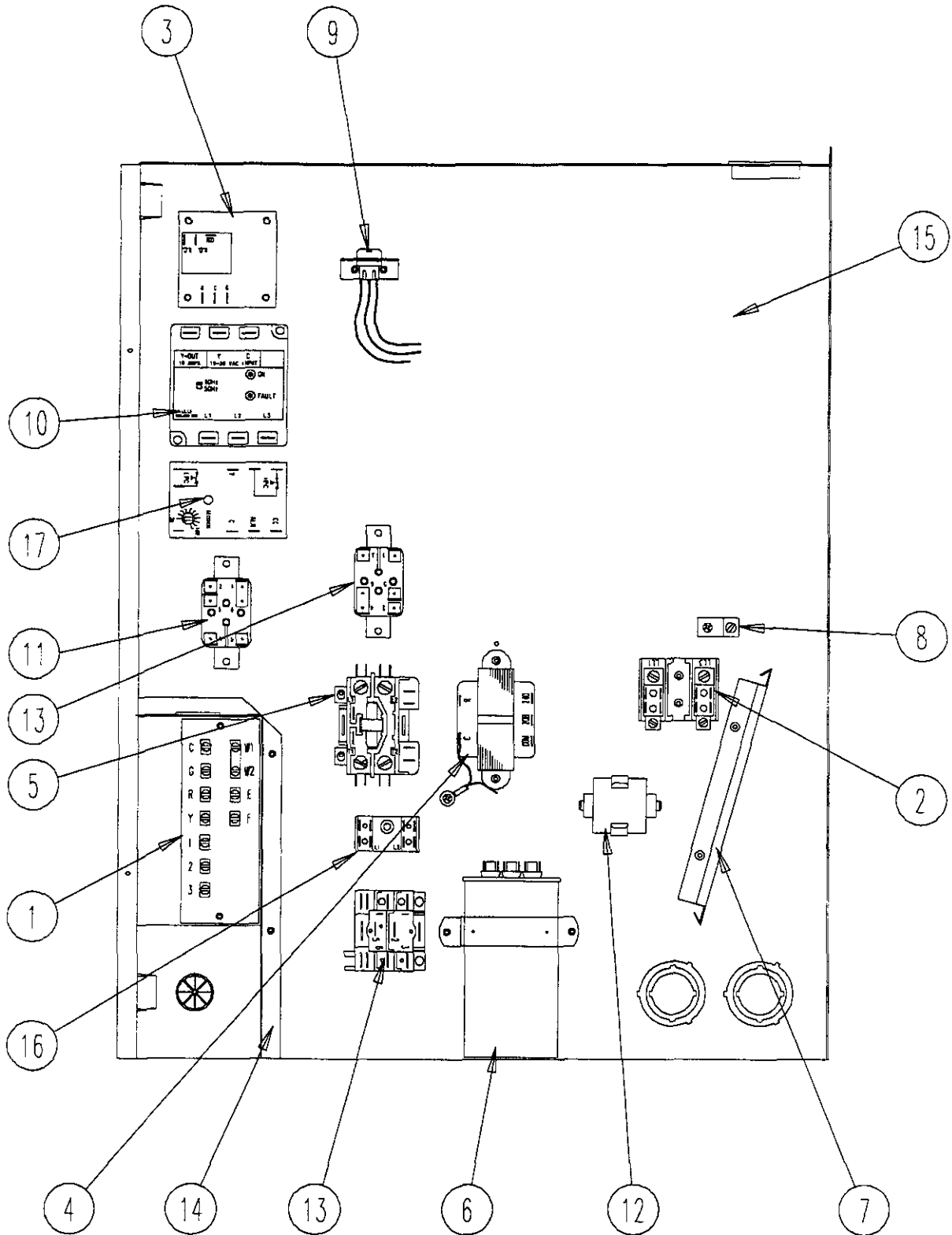

SEXP-180

CONTROL PANEL

Drawing No.	Part No.	Description	WA701-A	WA701-B	WA701-C	WA701-F	WA721-B
1	8607-020	Low Voltage Terminal Strip	X	X	X	X	X
2	8607-013	Terminal Block 2 Pole	X			2	
2	8607-014	Terminal Block 3 Pole		X	X		X
2	8607-015	Phenolic Insulator			X		
3	8201-056	Blower Control	X	X		X	X
3	8201-032	Blower Relay			X		
4	8407-034	Transformer	X	X		X	X
4	8407-042	Transformer			X		
5	8401-016	Compressor Contactor	X				
5	8401-002	Compressor Contactor			X		
5	8401-027	Compressor Contactor		X		X	X
6	8552-059	Compressor Capacitor	X				
6	8552-005	Outdoor Motor Capacitor		X	X	X	
6	8552-002	Outdoor Motor Capacitor					X
7	135-122	Wire Shield	X	X	X	X	X
8	8611-006	Ground Terminal	X	X	X	X	X
9	3000-978	6 Pin Connector	X	X	X	X	X
10	8201-085	Phase Monitor		X	X	X	X
11	8201-062	Alarm Relay (Optional)	X	X	X	X	X
12	8552-003	Start Kit (Optional)	X				
13	8201-009	Crankcase Heat Relay	X	X			X
13	8201-032	Crankcase Heat Relay			X		
14	117X139	Low Voltage Box	X	X	X	X	X
15	117X143	Control Panel	X	X	X	X	X
16	8607-017	Terminal Block (Optional)	X	X	X	X	X
17	8201-081	Compressor Control Module	X	X	X	X	X
NS	4095-129	Wiring Diagram	X				
NS	4095-231	Wiring Diagram		X			X
NS	4095-320	Wiring Diagram			X		
NS	4095-627	Wiring Diagram				X	

NS = Not Shown

BLOWER ASSEMBLY

Drawing No.	Part No.	Description	900-185	900-186
1	5152-011	10 Inch Wheel (CW)	X	X
2	5152-012	10 Inch Wheel (CCW)	X	X
3	8106-030	Blower Motor (230/208)	X	
3	8106-025	Blower Motor (460)		X
4	8552-005	Capacitor	X	X
5	8200-040	Motor Mount	X	X
6	5451-011	Grommets	6	6
7	105-880	Back Brace	X	X
8	105-881	Side Angle	4	4
9	103-389	Front Brace	X	X
10	151-101	Housing	2	2
11	144-166	Diffuser	2	2

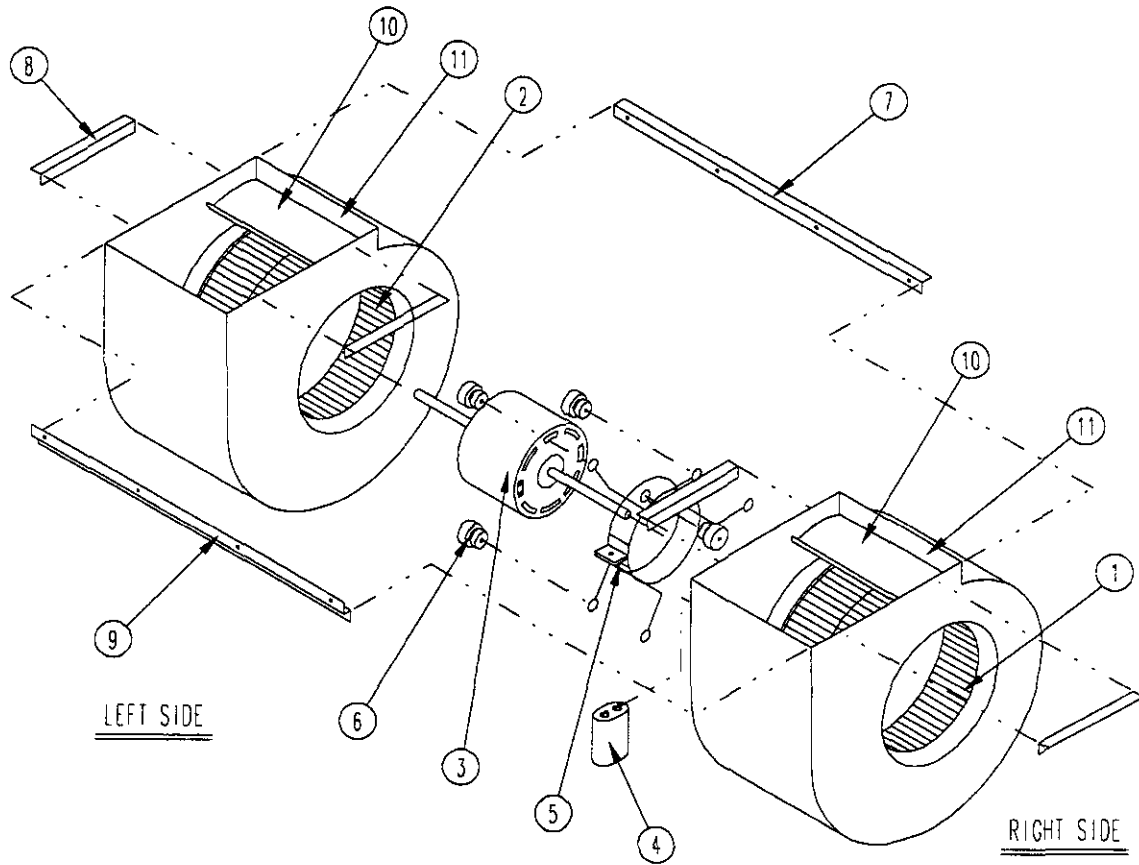

SEXP-178