Replacement Parts Manual

Wall Mounted Package Air Conditioner

Models: WA701, WA721

General Notes

- Revised and/or additional pages may be issued from time to time.
- A complete and current manual consists of pages shown in the following contents section.

Important

- Contact the installing and/or local Bard distributor for all parts requirements. Make sure you have the complete model and serial number available from the unit rating plates.

Contents

Description	Page
Cabinet Components	
♦ Exploded View	1
♦ Usage List	2
Functional Components	
♦ Exploded View	3
♦ Usage List	4
Control Panel	
♦ Exploded View	5
♦ Usage List	5
Blower Assembly	
♦ Exploded View	6
♦ Usage List	6



BARD MANUFACTURING COMPANY
Bryan, Ohio 43506

Since 1914...Moving ahead, just as planned.

Manual: 2110-415 Rev. B
File: 2150-004, Tab 16
Date: 01/16/96

Cabinet Components

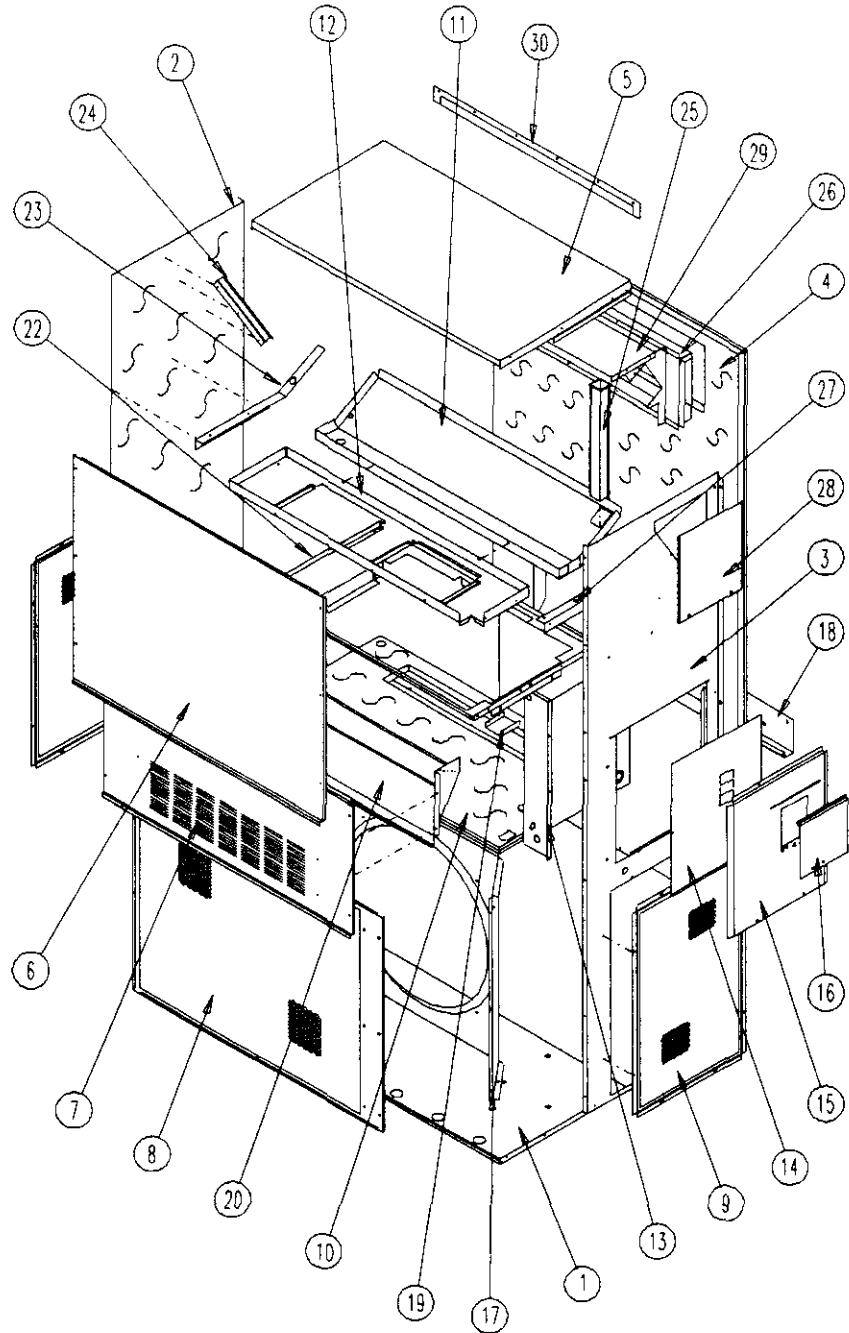

Cabinet Components

Drawing No.	Part No.	Description	WA701-B	WA701-C	WA721-B
1	S127-114	Lower Base	•	•	•
2	S500-316-* ①	Left Side	•	•	•
3	S500-315-* ①	Right Side	•	•	•
4	S508-098	Back	•	•	•
5	S506-142-* ①	Top	•	•	•
6	S514-077-* ①	Upper Front	•	•	•
7	S552-224-* ①	Service Door	•	•	•
8	118-040-* ①	Condenser Grille	•	•	•
9	118-041-* ①	Side Grille	2	2	2
10	S520-258	Condenser Partition	•	•	•
11	123-083	Drain Pan	•	•	•
12	121-216	Blower Partition	•	•	•
13	Control Panel Assembly	See Control Panel Assembly Drawing and Parts List	•	•	•
14	S133-144	Control Panel Cover (Inner)	•	•	•
14	S133-115	Control Panel Cover (Inner)	•	•	•
15	S533-113-* ①	Control Panel Cover Outer	•	•	•
16	S153-218-*	Disconnect Access Door	•	•	•
17	125-024	Fan Shroud	•	•	•
18	113-140	Bottom Mounting Bracket	•	•	•
19	137-209	Fill	•	•	•
20	960024	Fresh Air Damper Assembly	•	•	•
22	131-099	Filter Tray	•	•	•
23	105-877	Left Side Support	•	•	•
24	147-046-* ①	Left Evaporator Support	•	•	•
25	135-128	Raceway	2	2	2
26	111-034	Outlet Airframe Assembly	•	•	•
27	105-878	Right Side Support	•	•	•
28	S143-042-* ①	Right Side Cover Plate (Outer)	•	•	•
29	135-129	Heat Shield	•	•	•
30	113-150-* ①	Top Rain Flashing	•	•	•

① NOTE: Exterior cabinet parts are manufactured with various paint color options. To insure that you receive the proper paint color, you must include the complete model and serial number of the unit for which cabinet parts are being ordered.

Functional Components

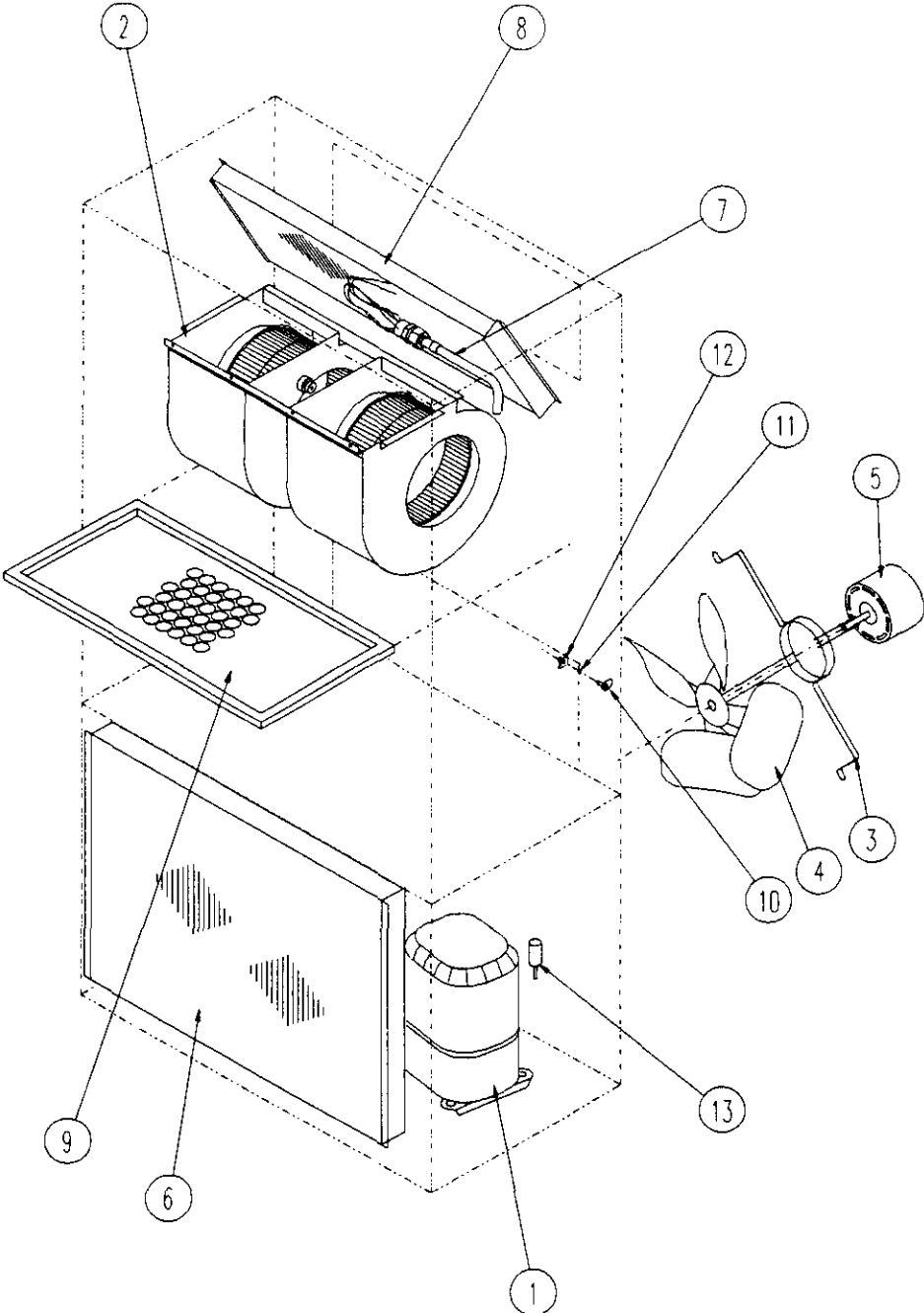

Control Panel

Drawing			WA701-B	WA701-C	WA721-B
No.	Part No.	Description			
1	8000-187	Compressor	•		•
1	8000-190	Compressor		•	
2	S900-185	Blower Assembly	•		•
2	S900-186	Blower Assembly		•	
3	8200-004	Fan Motor Mount	•	•	•
4	5151-027	Fan Blade	•	•	
4	5151-030	Fan Blade			•
5	8105-039	Condenser Motor	•		
5	8105-030	Condenser Motor (460V)		•	
5	8106-016	Condenser Motor			•
6	5051-088	Condenser Coil	•	•	•
7	5651-131	Expansion Valve	•	•	•
8	5060-082	Evaporator Coil	•	•	•
9	7004-016	Air Filter 1" Throw-Away	•	•	•
9	7003-030	Air Filter 1" Washable	•	•	•
9	7004-027	Air Filter 2" Pleated	•	•	•
10	1171-022	1/4" Turn Fastener	•	•	•
11	1171-024	1/4" Turn Retainer	•	•	•
12	1171-023	1/4" Receptacle	•	•	•
13	8406-055	High Pressure Switch (Solder)	•	•	•
NS	8406-061	Low Pressure Switch (Solder) (Optional)	•	•	•
NS	8406-062	Low Ambient Control (Solder) (Optional)	•	•	•
NS	1804-0106	High Pressure Switch (Flare) (Optional)	•	•	•
NS	1804-0107	Low Pressure Switch (Flare) (Optional)	•	•	•
NS	1804-0108	Low Ambient Control (Flare) (Optional)	•	•	•

NS — Not Shown

Blower Assembly

Drawing No.	Part No.	Description	WA701-B	WA701-C	WA721-B
1	8607-020	Low Voltage Terminal Strip	•	•	•
2	8607-014	Terminal Block 3 Pole	•	•	•
2	8607-015	Phelon Insulator		•	
3	8201-056	Blower Control	•		•
3	8201-032	Blower Relay		•	
4	8407-034	Transformer	•		•
4	8407-042	Transformer		•	
5	8401-002	Compressor Contactor		•	
5	8401-027	Compressor Contactor	•		•
6	8552-005	Outdoor Motor Capacitor	•	•	
6	8552-004	Outdoor Motor Capacitor			•
7	135-130	Wire Shield	•	•	•
8	8611-006	Ground Terminal	•	•	•
9	3000-978	6 Pin Connector	•	•	•
10	8201-034	Lockout Relay	•	•	•
11	8201-065	Low Pressure Bypass (TDR) (Optional)	•	•	•
12	8201-050	Compressor TDR	•	•	•
12	8201-067	Compressor TDR Adj. (Optional)	•	•	•
13	8201-062	Alarm Relay (Optional)	•	•	•
15	8201-009	Crankcase Heat Relay	•		•
15	8201-032	Crankcase Heat Relay		•	
16	117-139	Low Voltage Box	•	•	•
17	117-143	Control Panel	•	•	•
18	8607-017	Terminal Block (Optional)	•		•
	4095-219	Wiring Diagram	•		•
	4095-313	Wiring Diagram		•	

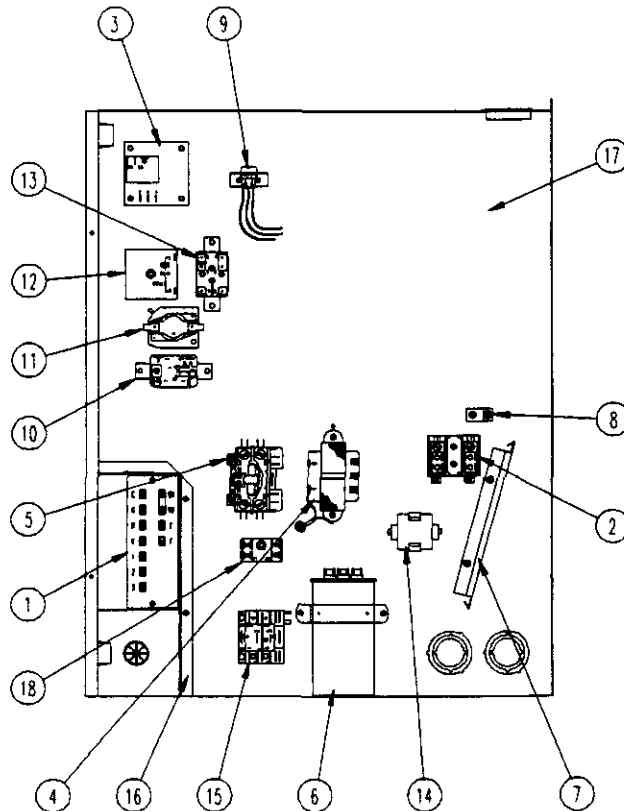

Functional Components

Drawing No.	Part No.	Description	900-185	900-186
1	5152-011	10 Inch Wheel (CW)	•	•
2	5152-012	10 Inch Wheel (CCW)	•	•
3	8106-030	Blower Motor (230/208)	•	
3	8106-025	Blower Motor (460)		•
4	8552-005	Capacitor	•	•
5	8200-040	Motor Mount	•	•
6	5451-011	Grommets	6	6
7	105-880	Back Brace	•	•
8	105-881	Side Angle	4	4
9	103-389	Front Brace	•	•
10	151-101	Housing	2	2
11	144-166	Diffuser	2	2

