

REPLACEMENT PARTS MANUAL

WALL MOUNTED PACKAGE AIR CONDITIONER

MODELS: WA421, WA482, WA602

Manual 2110-413

Revision D

Date 05-09-96

Supersedes 10-01-95

* GENERAL NOTES *

*Revised and/or additional pages may be issued from time to time.
*A complete and current manual consists of pages dated as shown in the following index.

** INDEX **

<u>Page Description</u>	<u>Page</u>	<u>Date</u>	<u>Supersedes</u>
Cabinet Components--Exploded View	1	10-12-94	11-11-93
" " --Usage List	2	05-09-96	10-12-94
Functional Components--Exploded View	3	11-11-93	
" " --Usage List	4	10-01-95	3-01-94
Control Panel--Layout	5	11-11-93	
" " --Usage List	6	05-09-96	03-01-94
Blower Assembly--Exploded View, Usage List	7	11-11-93	

*** IMPORTANT ***

Contact the installing and/or local Bard distributor for all parts requirements. Make sure you have the complete model and serial number available from the unit rating plate.

BARD MANUFACTURING COMPANY

BRYAN, OHIO 43506

CABINET COMPONENTS

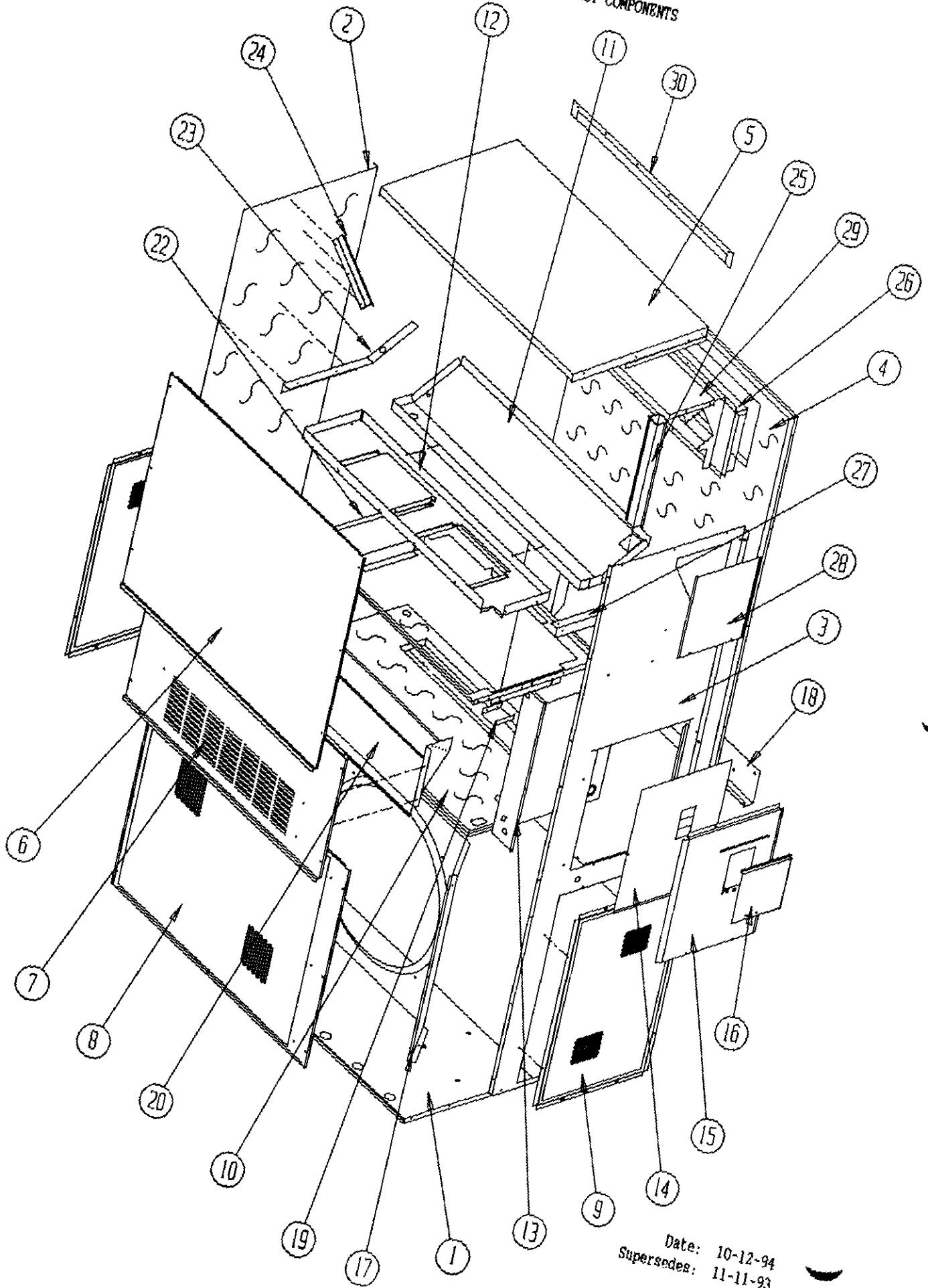

Date: 10-12-94
Supersedes: 11-11-93

CABINET COMPONENTS

Dwg. No.	Part No.	Description	W A 4 2 1 - A, B, E	W A 4 2 1 - C, F	W A 4 2 1 D A, B	W A 4 2 1 D C	W A 4 8 2 - A, B, E	W A 4 8 2 - C, F	W A 4 8 2 D A, B	W A 4 8 2 D C	W A 6 0 2 - A, B, E	W A 6 0 2 - C, F
1	S127X214	Lower Base	x	x	x	x	x	x	x	x	x	x
2	(1) S500-262-*	Left Side	x	x	x	x	x	x	x	x	x	x
3	(1) S500-261-*	Right Side	x	x	x	x	x	x	x	x	x	x
4	S508-098	Back	x	x	x	x	x	x	x	x	x	x
5	(1) S506-142-*	Top	x	x	x	x	x	x	x	x	x	x
6	(1) S514-077-*	Upper Front	x	x	x	x	x	x	x	x	x	x
7	(1) S552-224-*	Service Door	x	x	x	x	x	x	x	x	x	x
8	(1) 118-031-*	Condenser Grille	x	x	x	x	x	x	x	x	x	x
9	(1) 118-032-*	Side Grille	2	2	2	2	2	2	2	2	2	2
10	S521X258	Condenser Partition	x	x	x	x	x	x	x	x	x	x
11	123-083	Drain Pan	x	x	x	x	x	x	x	x	x	x
12	121X216	Blower Partition	x	x	x	x	x	x	x	x	x	x
13	Control Panel Assembly	See Control Panel Assembly Drawing and Parts List	x	x	x	x	x	x	x	x	x	x
14	S133-114	Control Panel Cover (Inner)	x		x		x		x		x	
14	S133-115	Control Panel Cover (Inner)		x		x		x		x		x
15	(1) S533-113-*	Control Panel Cover (Outer)	x	x	x	x	x	x	x	x	x	x
16	(1) S153-218-*	Disconnect Access Door	x	x	x	x	x	x	x	x	x	x
17	125-024	Fan Shroud	x	x	x	x	x	x	x	x	x	x
18	113-140	Bottom Mounting Bracket	x	x	x	x	x	x	x	x	x	x
19	137-209	Fill	x	x	x	x	x	x	x	x	x	x
20	960024	Fresh Air Damper Assembly	x	x	x	x	x	x	x	x	x	x
22	131X099	Filter Tray	x	x	x	x	x	x	x	x	x	x
23	105X877	Left Side Support	x	x	x	x	x	x	x	x	x	x
24	(1) 147-046-*	Left Evaporator Support	x	x	x	x	x	x	x	x	x	x
25	135-128	Raceway	2	2	2	2	2	2	2	2	2	2
26	111X034	Outlet Airframe Assembly	x	x	x	x	x	x	x	x	x	x
27	105X878	Right Side Support	x	x	x	x	x	x	x	x	x	x
28	(1) S143-042-*	Right Side Cover Plate (Outer)	x	x	x	x	x	x	x	x	x	x
29	135-129	Heat Shield	x	x	x	x	x	x	x	x	x	x
30	(1) 113-150-*	Top Rain Flashing	x	x	x	x	x	x	x	x	x	x

(1) NOTE: Exterior cabinet parts are manufactured with various paint color options. To insure that you receive the proper paint color, you must include the complete model and serial number of the unit for which cabinet parts are being ordered.

FUNCTIONAL COMPONENTS

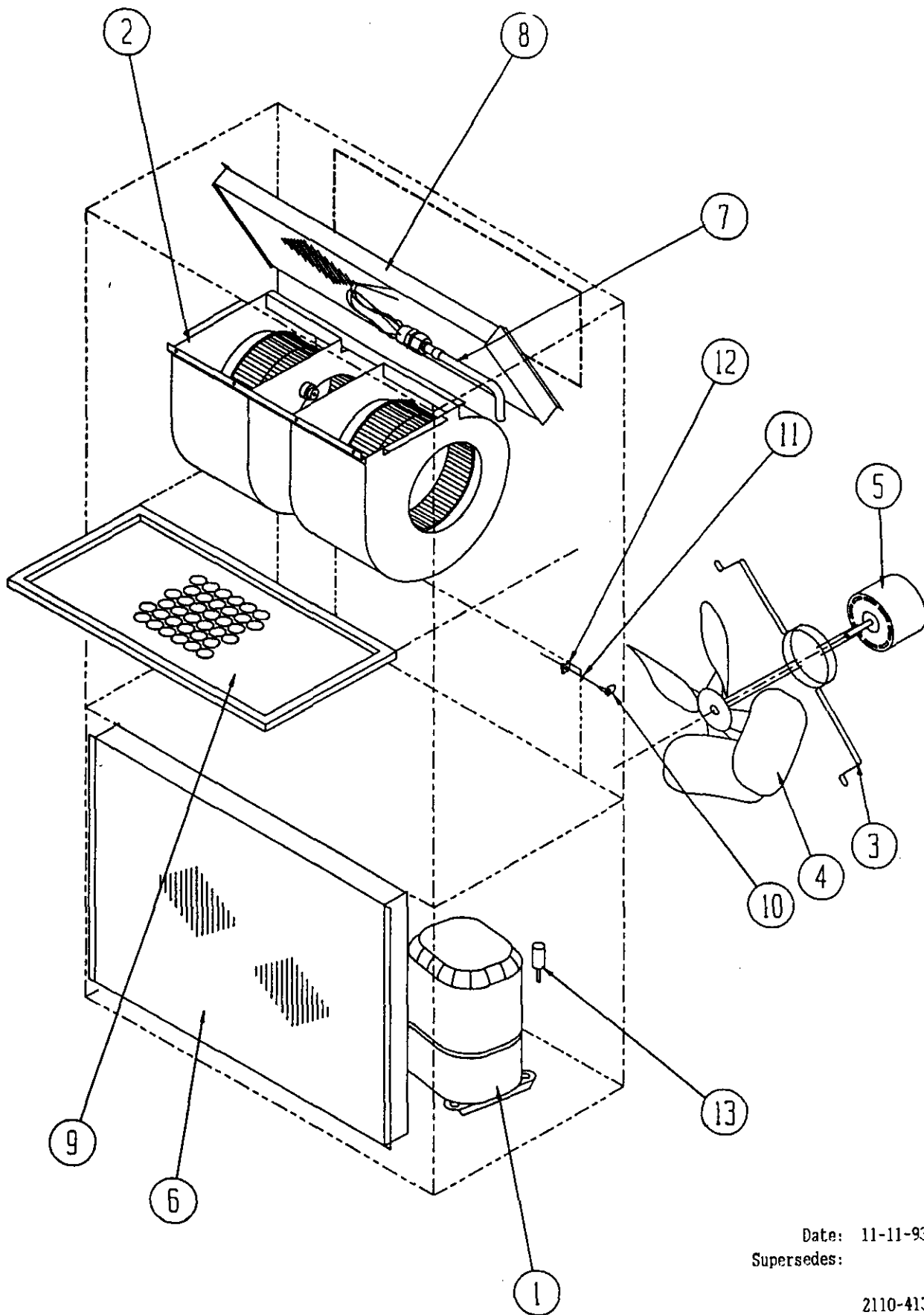

Date: 11-11-93
Supersedes:

2110-413
Page: 3

FUNCTIONAL COMPONENTS

Dwg. No.	Part No.	Description	W	W	W	W	W	W	W	W	W	W	W	W	W	W	W	W	W	W	W
			A	A	A	A	A	A	A	A	A	A	A	A	A	A	A	A	A	A	A
			4	4	4	4	4	4	4	4	4	4	4	4	4	4	4	4	4	4	4
			2	2	2	2	2	2	2	2	2	2	2	2	2	2	2	2	2	2	2
			1	1	1	1	1	1	1	1	1	1	1	1	1	1	1	1	1	1	1
			-	-	-	-	D	D	D	-	-	-	-	D	D	D	-	-	-	-	-
			A	B, R	C	F	A	B	C	A	B, E	C	F	A	B	C	A	B, E	C	F	F
1	8000-153	Compressor																X			
1	8000-154	Compressor																	X		
1	8000-155	Compressor																		X	X
1	8000-126	Compressor	X				X														
1	8000-127	Compressor		X				X													
1	8000-128	Compressor			X	X				X											
1	8000-149	Compressor								X					X						
1	8000-156	Compressor									X					X					
1	8000-157	Compressor										X	X				X				
2	S900-183	Blower Assembly	X	X		X	X	X		X	X		X	X	X						
2	S900-184	Blower Assembly			X				X			X				X					
2	S900-185	Blower Assembly															X	X			X
2	S900-186	Blower Assembly																		X	
3	8200-004	Fan Motor Mount	X	X	X	X	X	X	X	X	X	X	X	X	X	X	X	X	X	X	X
4	5151-027	Fan Blade	X	X	X	X	X	X	X	X	X	X	X	X	X	X	X	X	X	X	X
5	8105-030	Condenser Motor			X				X			X				X				X	
5	8105-039	Condenser Motor	X	X		X	X	X		X	X		X	X	X		X	X			X
6	5051-074	Condenser Coil								X	X	X	X	X	X	X	X	X	X	X	X
6	5051-078	Condenser Coil	X	X	X	X	X	X	X												
7	5651-078	Expansion Valve					X	X	X						X	X	X				
7	800-0204	Cooling Capillary Assembly								X	X	X	X								
7	800-0203	Cooling Capillary Assembly	X	X	X	X															
7	800-0209	Cool Cap Assy (Serial # before M95)																X	X	X	X
7	800-0232	Cool Cap Assy (Serial # start M95)																X	X	X	X
8	5060-070	Evaporator Coil	X	X	X	X				X	X	X	X								
8	5060-071	Evap Coil (Serial # before M95)																X	X	X	X
8	5060-082	Evap Coil (Serial # starting M95)																X	X	X	X
8	917-0034	Evaporator Coil					X	X	X					X	X	X					
9	7004-016	Air Filter 1" Throw-Away	X	X	X	X	X	X	X	X	X	X	X	X	X	X	X	X	X	X	X
9	7003-030	Air Filter 1" Washable	X	X	X	X	X	X	X	X	X	X	X	X	X	X	X	X	X	X	X
9	7004-027	Air Filter 2" Pleated	X	X	X	X	X	X	X	X	X	X	X	X	X	X	X	X	X	X	X
10	1171-022	1/4" Turn Fastener	X	X	X	X	X	X	X	X	X	X	X	X	X	X	X	X	X	X	X
11	1171-024	1/4" Turn Retainer	X	X	X	X	X	X	X	X	X	X	X	X	X	X	X	X	X	X	X
12	1171-023	1/4" Receptacle	X	X	X	X	X	X	X	X	X	X	X	X	X	X	X	X	X	X	X
13	8406-055	High Pressure Switch (Solder)	(1)	(1)	(1)	(1)				X	X	X	X	X	X	X	X	X	X	X	X
NS	5650-027	Solenoid Coil					X	X	X					X	X	X					
NS	5650-026	Three-Way Valve					X	X	X					X	X	X					
NS	8406-061	Low Pressure Switch (Solder) (Opt)	X	X	X	X				X	X	X	X				X	X	X	X	X
NS	8406-062	Low Ambient Control (Solder) (Opt)	X	X	X	X				X	X	X	X				X	X	X	X	X
NS	1804-0106	High Pressure Switch (Flare) (Opt)	X	X	X	X				X	X	X	X	X	X	X	X	X	X	X	X
NS	1804-0107	Low Pressure Switch (Flare) (Opt)	X	X	X	X				X	X	X	X				X	X	X	X	X
NS	1804-0108	Low Ambient Control (Flare) (Opt)	X	X	X	X				X	X	X	X				X	X	X	X	X

NS - Not Shown

(1) Optional on these models

Date: 10-01-95
Supersedes: 3-01-94

2110-413

CONTROL PANEL

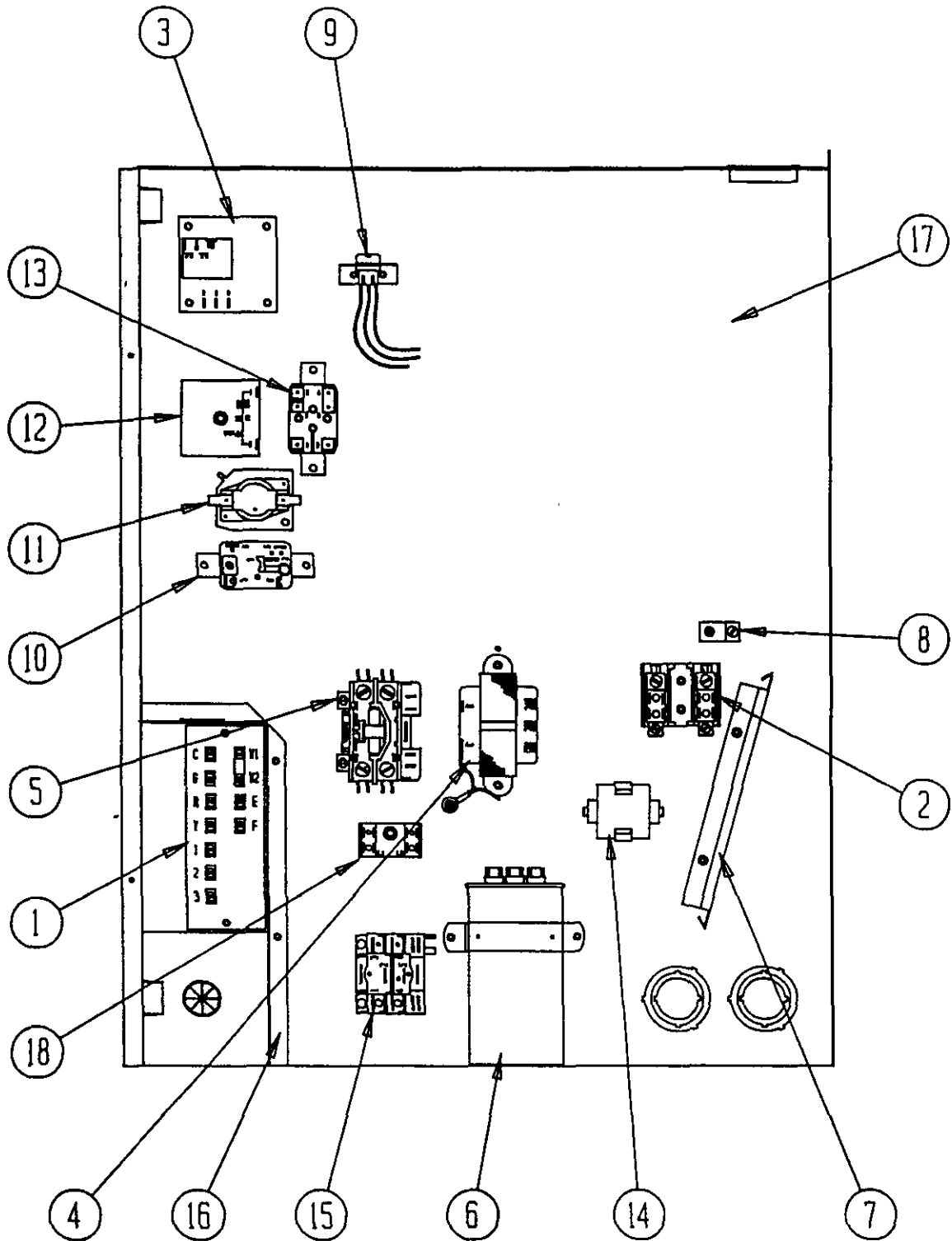

Date: 11-11-93
Supersedes:

CONTROL PANEL

Dwg. No.	Part No.	Description	W	W	W	W	W	W	W	W	W	W	W	W	W	W	W	W	W	W	W	W	W	W
			A	A	A	A	A	A	A	A	A	A	A	A	A	A	A	A	A	A	A	A	A	A
			4	4	4	4	4	4	4	4	4	4	4	4	4	4	4	4	4	4	4	4	4	4
			2	2	2	2	2	2	2	2	2	2	2	2	2	2	2	2	2	2	2	2	2	2
			1	1	1	1	1	1	1	1	1	1	1	1	1	1	1	1	1	1	1	1	1	1
			-	-	-	-	-	-	-	-	-	-	-	-	-	-	-	-	-	-	-	-	-	-
			A	B	C	E	F	A	B	C	A	B	C	E	F	A	B	C	A	B	C	E	F	
1	8607-020	Low Voltage Terminal Strip	X	X	X	X	X	X	X	X	X	X	X	X	X	X	X	X	X	X	X	X	X	
2	8607-013	Terminal Block 2 Pole	X				2	X			X					2	X			X			2	
2	8607-014	Terminal Block 3 Pole		X	X	X			X	X		X	X	X			X	X		X	X	X		
2	8607-015	Phelon Insulator			X				X		X		X				X			X		X		
3	8201-056	Blower Control	X	X		X	X	X	X		X	X		X	X	X	X		X	X		X	X	
3	8201-032	Blower Relay			X				X		X		X				X			X		X		
4	8407-034	Transformer	X	X		X	X			X	X		X	X				X	X		X	X		
4	8407-035	Transformer						X	X							X	X							
4	8407-042	Transformer			X				X		X		X				X			X		X		
5	8401-002	Compressor Contactor		X	X	X	X		X	X		X	X	X	X		X	X		X	X	X	X	
5	8401-007	Compressor Contactor	X					X																
5	8401-016	Compressor Contactor								X						X			X					
6	8552-005	Outdoor Motor Capacitor		X		X	X		X		X		X	X	X		X		X		X	X		
6	8552-026	Outdoor Motor Capacitor			X				X		X		X				X			X		X		
6	8552-055	Compressor Capacitor	X					X											X					
6	8552-058	Compressor Capacitor																X						
6	8552-059	Compressor Capacitor								X						X								
7	135-130	Wire Shield	X	X	X	X	X	X	X	X	X	X	X	X	X	X	X	X	X	X	X	X	X	
8	8611-006	Ground Terminal	X	X	X	X	X	X	X	X	X	X	X	X	X	X	X	X	X	X	X	X	X	
9	3000-978	6 Pin Connector	X	X	X	X	X	X	X	X	X	X	X	X	X	X	X	X	X	X	X	X	X	
10	8201-034	Lockout Relay	(1)	(1)	(1)	(1)	(1)	(1)	(1)	(1)	(1)	X	X	X	X	X	X	X	X	X	X	X	X	
10	8201-062	Control Relay #2						X	X	X						X	X	X						
11	8201-065	Low Pressure Bypass (TDR) (Opt)	X	X	X	X	X				X	X	X	X	X				X	X	X	X	X	
11	8201-071	Control Relay #1						X	X	X						X	X	X						
12	8201-050	Compressor TDR	(1)	(1)	(1)	(1)	(1)	X	X	X	(1)	(1)	(1)	(1)	(1)	X	X	X	(1)	(1)	(1)	(1)	(1)	
12	8201-067	Compressor TDR Adj (Optional)	X	X	X	X	X				X	X	X	X	X				X	X	X	X	X	
13	8201-062	Alarm Relay (Optional)	X	X	X	X	X				X	X	X	X	X				X	X	X	X	X	
14	8551-005	Start Device (PTCR) (Optional)	X					X																
15	8201-032	Outdoor Fan Relay (Optional)			X					X			X					X			X			
16	117X139	Low Voltage Box	X	X	X	X	X	X	X	X	X	X	X	X	X	X	X	X	X	X	X	X	X	
17	117X143	Control Panel	X	X	X	X	X	X	X	X	X	X	X	X	X	X	X	X	X	X	X	X	X	
18	8607-017	Terminal Block (Optional)	X	X		X	X				X	X		X	X				X	X		X	X	
	4095-110	Wiring Diagram	X																					
	4095-112	Wiring Diagram									X								X					
	4095-118	Wiring Diagram						X																
	4095-121	Wiring Diagram														X								
	4095-210	Wiring Diagram		X																				
	4095-212	Wiring Diagram									X								X					
	4095-213	Wiring Diagram				X							X									X		
	4095-214	Wiring Diagram				X																		
	4095-220	Wiring Diagram														X								
	4095-221	Wiring Diagram							X															
	4095-310	Wiring Diagram			X																			
	4095-313	Wiring Diagram										X									X			
	4095-315	Wiring Diagram								X														
	4095-316	Wiring Diagram															X							
	4095-611	Wiring Diagram												X									X	
	4095-612	Wiring Diagram					X																	

(1) Optional on these models

BLOWER ASSEMBLY

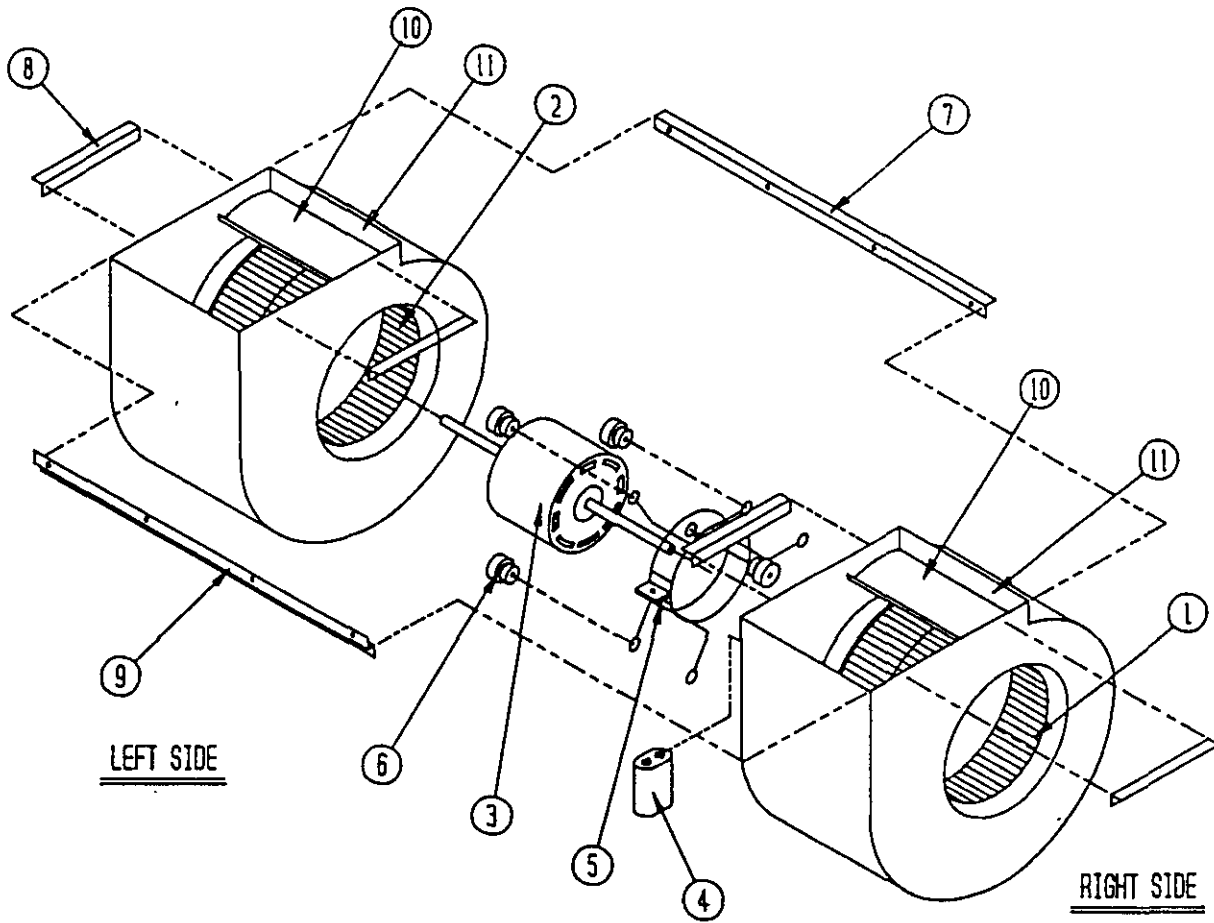

BLOWER ASSEMBLY

Dwg. No.	Part No.	Description	9 0 0 1 8 3	9 0 0 1 8 4	9 0 0 1 8 5	9 0 0 1 8 6
1	5152-011	10 Inch Wheel (CW)			X	X
1	5152-057	9 Inch Wheel (CW)	X	X		
2	5152-012	10 Inch Wheel (CCW)			X	X
2	5152-058	9 Inch Wheel (CCW)	X	X		
3	8106-030	Blower Motor (230/208)	X		X	
3	8106-025	Blower Motor (460)		X		X
4	8552-005	Capacitor	X	X	X	X
5	8200-040	Motor Mount	X	X	X	X
6	5451-011	Grommets	6	6	6	6
7	105-880	Back Brace	X	X	X	X
8	105-881	Side Angle	4	4	4	4
9	103-389	Front Brace	X	X	X	X
10	151-101	Housing	2	2	2	2
11	144-166	Diffuser	2	2	2	2

Date: 11-11-93

Supersedes:

2110-413

Page: 7