

# REPLACEMENT PARTS MANUAL

## WALL MOUNTED PACKAGE AIR CONDITIONER

MODEL: WA121

Manual 2110-412

Revision B

Date 3-01-94

Supersedes 1-15-94

\*\*\*\*\*  
\* GENERAL NOTES \*  
\*\*\*\*\*

\*Revised and/or additional pages may be issued from time to time.  
\*A complete and current manual consists of pages dated as shown in the following index.

\*\*\*\*\*  
\*\* INDEX \*\*  
\*\*\*\*\*

<u>Page Description</u>	<u>Page</u>	<u>Date</u>	<u>Supersedes</u>
Cabinet Components--Exploded View	1	7-22-93	
" " --Usage List	2	3-01-94	1-15-94
Functional Components--Exploded View	3	7-22-93	
" " --Usage List	4	3-01-94	1-15-94
Control Panel--Layout	5	7-22-93	
" " --Usage List	6	3-01-94	1-15-94
Blower Assembly--Exploded View, Usage List	7	3-01-94	7-22-93

\*\*\*\*\*  
\*\*\* IMPORTANT \*\*\*  
\*\*\*\*\*

Contact the installing and/or local Bard distributor for all parts requirements. Make sure you have the complete model and serial number available from the unit rating plate.

BARD MANUFACTURING COMPANY

BRYAN, OHIO 43506

CABINET COMPONENTS

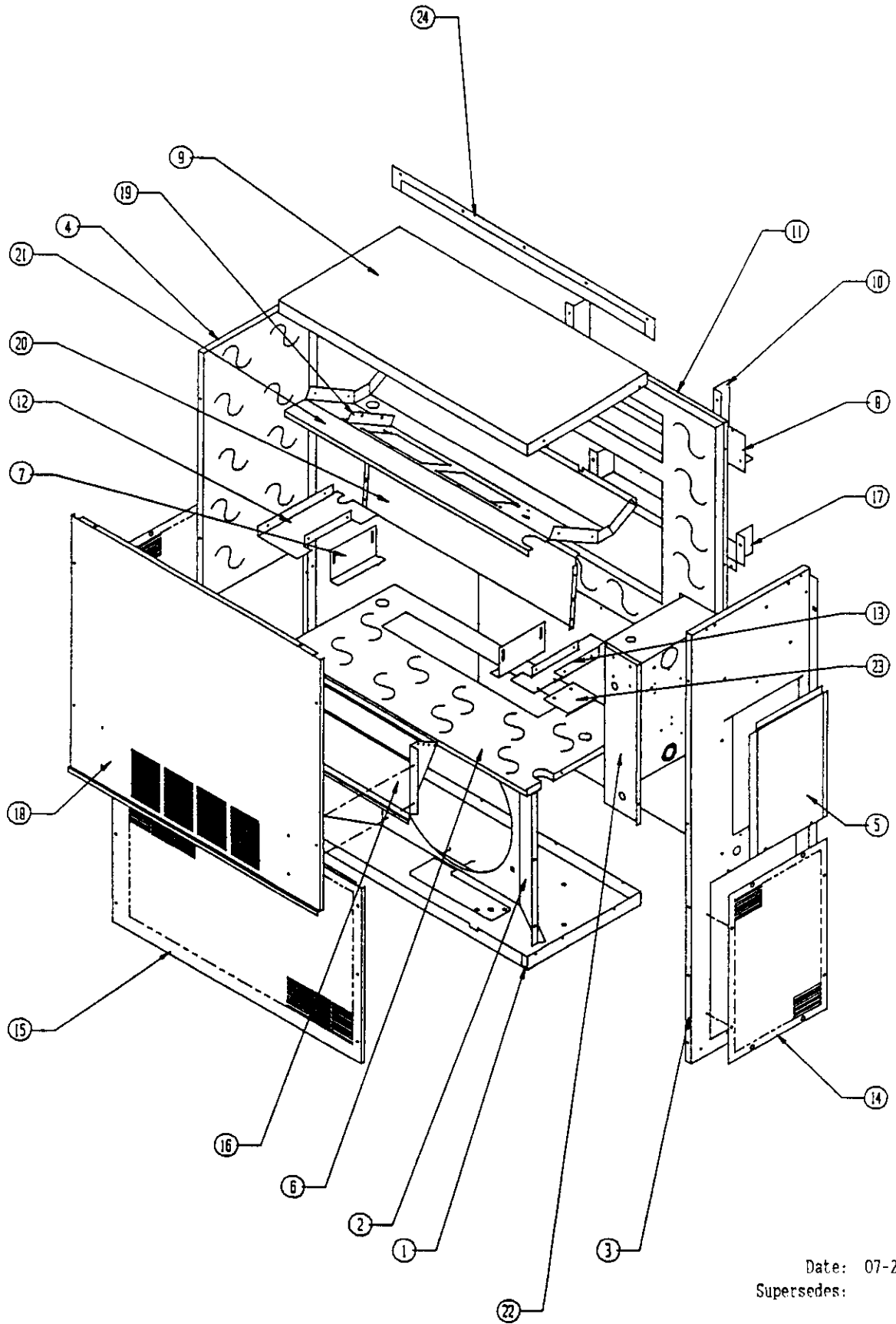

Date: 07-22-93  
Supersedes:

CABINET COMPONENTS

Dwg. No.	Part No.	Description	W	W	W
			A	A	A
			1	1	1
			2	2	2
			1	1	1
			-	-	-
			A	K	G
1	S126-223	Lower Base	X	X	X
2	124-025	Fan Shroud	X	X	X
3	(1) S500-275-*	Right Side	X	X	X
4	(1) S500-274-*	Left Side	X	X	X
5	(1) S133-120-*	Control Panel Cover (Outer)	X	X	X
6	S520-243	Condenser Partition	X	X	X
7	113-166	Filter Bracket Angle	2	2	2
8	111-037	Top Return Air Frame Angle	X	X	X
9	(1) S506-148-*	Top	X	X	X
10	111-036	Outlet Airframe Angle	X	X	X
11	S508-102	Back	X	X	X
12	113-165	Left Filter Bracket	X	X	X
13	113-166	Right Filter Bracket	X	X	X
14	(1) 118-035-*	Side Grille	2	2	2
15	(1) 119-036-*	Condenser Grille	X	X	X
16	962031	Fresh Air Damper Assembly	X	X	X
17	111-038	Bottom Return Air Frame Angle	X	X	X
18	(1) S514-085-*	Upper Front	X	X	X
19	113-176	Heater Bracket	X	X	X
20	121-245	Return Partition	X	X	X
21	S121-244	Drain Pan	X	X	X
22	Control Panel Assembly	See Control Panel Assembly Drawing and Parts List	X	X	X
23	135-138	Fill Plate	X	X	X
24	(1) 113-178-*	Top Rain Flashing	X	X	X

(1) NOTE: Exterior cabinet parts are manufactured with various paint color options. To insure that you receive the proper paint color, you must include the complete model and serial number of the unit for which cabinet parts are being ordered.

Date: 3-01-94  
Supersedes: 1-15-94

2110-412

Page: 2

FUNCTIONAL COMPONENTS

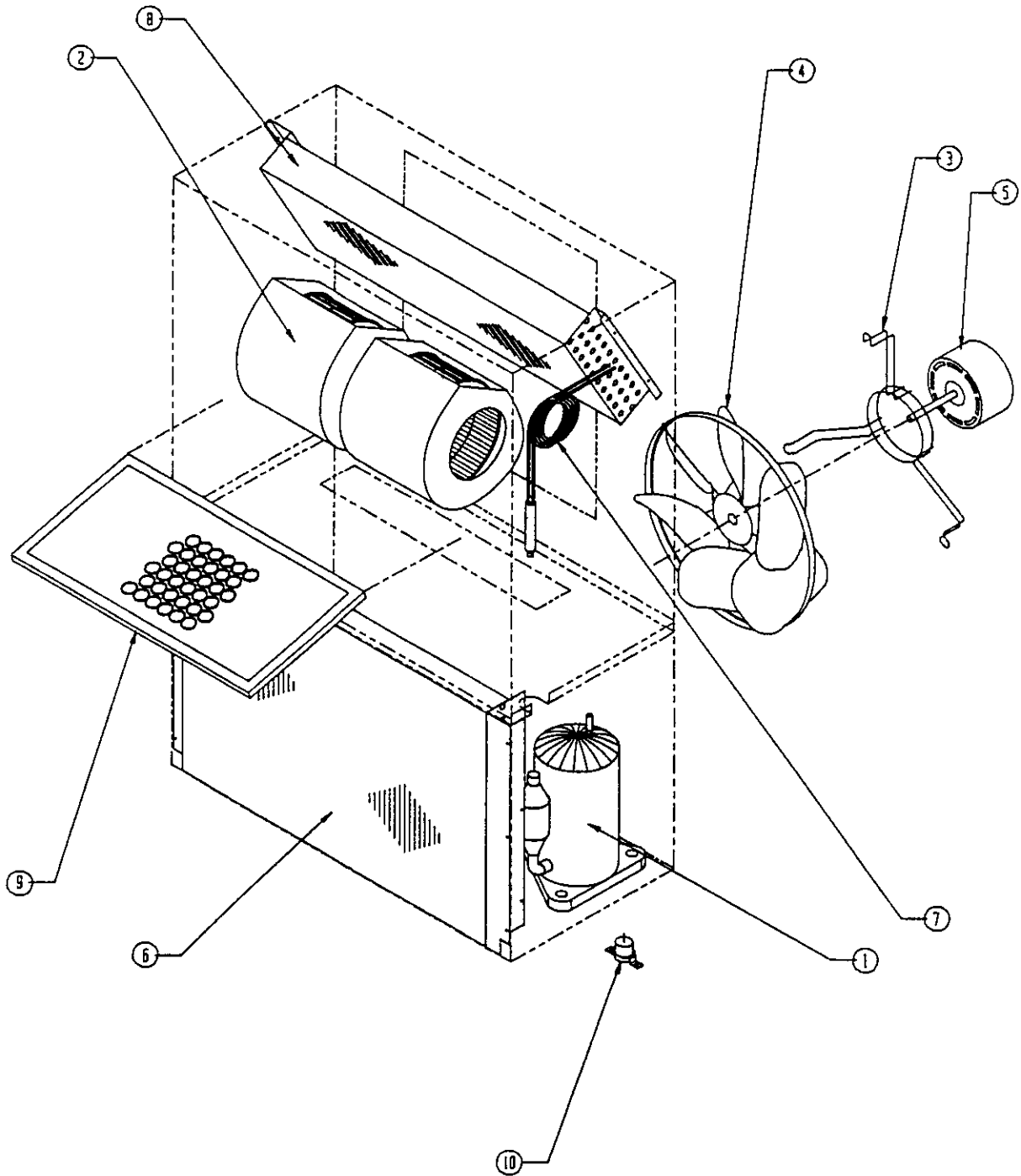

Date: 7-22-93  
Supersedes:

FUNCTIONAL COMPONENTS

Dwg. No.	Part No.	Description	W	W	W
			A	A	A
			1	1	1
			2	2	2
			1	1	1
			-	-	-
			A	K	G
1	8000-158	Compressor	x		
1	8000-159	Compressor		x	
1	8000-161	Compressor			x
2	S900-200	Blower Assembly 240V	x		x
2	S900-201	Blower Assembly 115V		x	
3	8200-041	Fan Motor Mount	x	x	x
4	5151-047	Fan Blade	x	x	x
5	8101-007	Condenser Motor 240V	x		x
5	8101-008	Condenser Motor 115V		x	
6	5051-081	Condenser Coil	x	x	x
7	800-0221	Cooling Capillary Assembly	x	x	x
8	5060-074	Evaporator Coil	x	x	x
9	7003-021	Air Filter 1" Washable	x	x	x
9	7004-001	Air Filter 1" Throw-Away	x	x	x
9	7004-028	Air Filter 2" Pleated (Optional)	x	x	x
10	5651-110	Drain Valve	x	x	x
NS	8406-055	High Pressure Switch (Solder)	x	x	x
NS	8406-061	Low Pressure Switch (Solder) (Optional)	x	x	x
NS	8406-062	Low Ambient Control (Solder) (Optional)	x	x	x
NS	1804-0107	Low Pressure Switch (Flare) (Optional)	x	x	x
NS	1804-0108	Low Ambient Control (Flare) (Optional)	x	x	x
NS	8402-085	Compressor Overload			x
NS	8402-086	Compressor Overload	x		
NS	8402-087	Compressor Overload		x	

NS = Not Shown

Date: 3-01-94  
Supersedes: 1-15-94

CONTROL PANEL

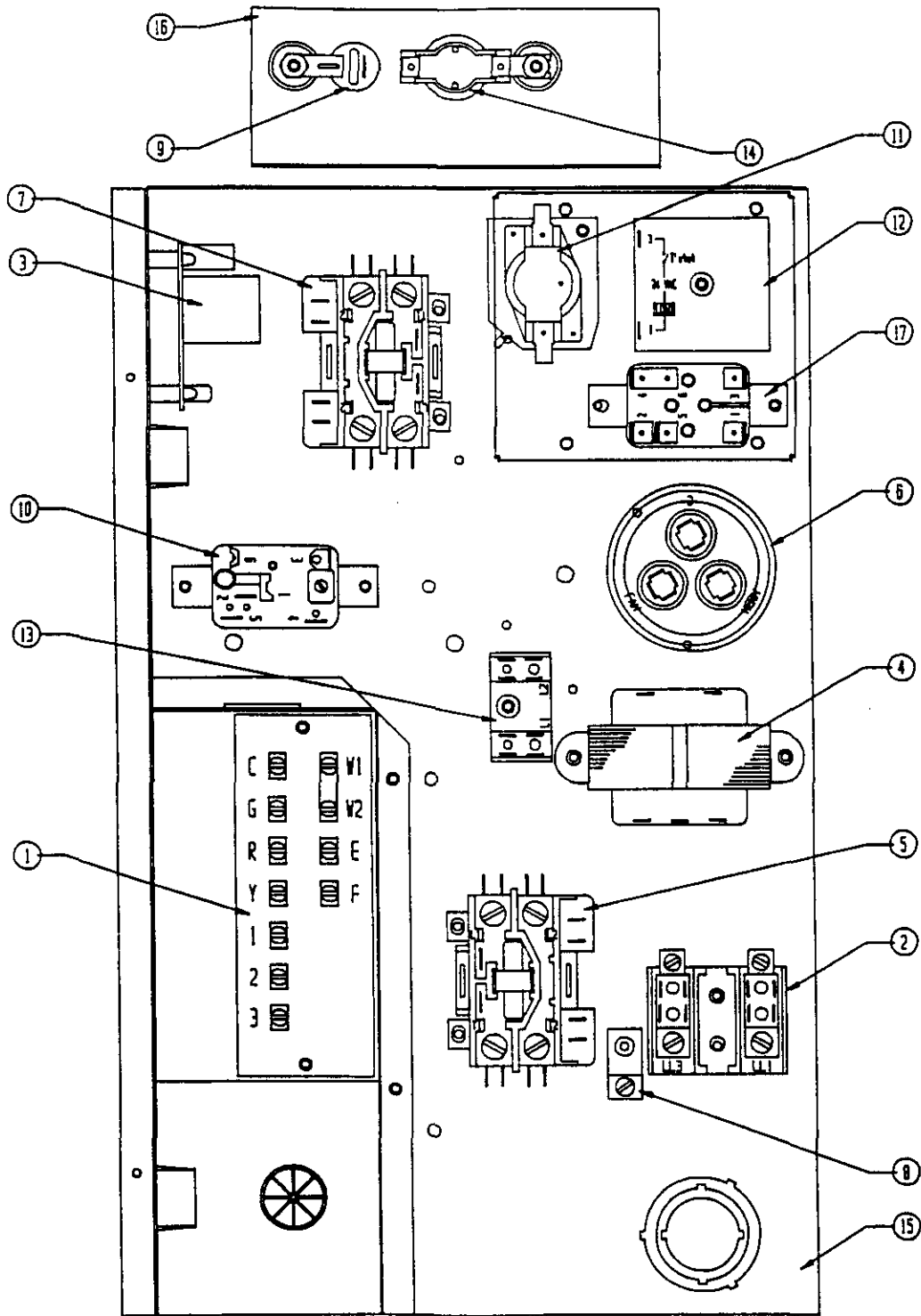

Date: 7-22-93  
Supersedes:

CONTROL PANEL

Dwg. No.	Part No.	Description	W	W	W	W	W	W	W	W
			A	A	A	A	A	A	A	A
			1	1	1	1	1	1	1	1
			2	2	2	2	2	2	2	2
			1	1	1	1	1	1	1	1
			-	-	-	-	-	-	-	-
			A	A	A	K	K	G	G	G
			0	0	0	0	0	0	0	0
			0	3	5	0	2	0	3	5
1	8607-020	Low Voltage Terminal Strip	X	X	X	X	X	X	X	X
2	8607-013	Terminal Block 2 Pole	X	X	X	X	X	X	X	X
3	8201-056	Blower Control	X	X	X	X	X	X	X	X
4	8407-034	Transformer	X	X	X			X	X	X
4	8407-039	Transformer				X	X			
5	8401-007	Compressor Contactor	X	X	X	X	X	X	X	X
6	8552-046	Compressor Capacitor	X	X	X	X	X	X	X	X
7	8401-007	Heat Contactor		X	X		X		X	X
8	8611-006	Ground Terminal	X	X	X	X	X	X	X	X
9	8402-025	Thermal Cut Off		X	X		X		X	X
10	8201-037	Lockout Relay	X	X	X	X	X	X	X	X
11	8201-065	Low Pressure Bypass (TDR) (Optional)	X	X	X	X	X	X	X	X
12	8201-050	Compressor TDR (Optional)	X	X	X	X	X	X	X	X
12	8201-067	Compressor TDR Adj (Optional)	X	X	X	X	X	X	X	X
13	8201-062	Alarm Relay (Optional)	X	X	X	X	X			
13	8607-017	Terminal Block (Optional)	X	X	X	X	X			
14	8402-084	Limit		X	X		X		X	X
15	117-154	Control Panel	X	X	X	X	X	X	X	X
16	8604-097	Heat Strip 3.6KW		X					X	
16	8604-098	Heat Strip 5.0KW			X					X
16	8604-099	Heat Strip 2.2KW					X			
	4095-114	Wiring Diagram		X	X				X	X
	4095-115	Wiring Diagram	X					X		
	4095-116	Wiring Diagram				X				
	4095-117	Wiring Diagram					X			

Date: 3-01-94  
Supersedes: 1-15-94

2110-412

BLOWER ASSEMBLY

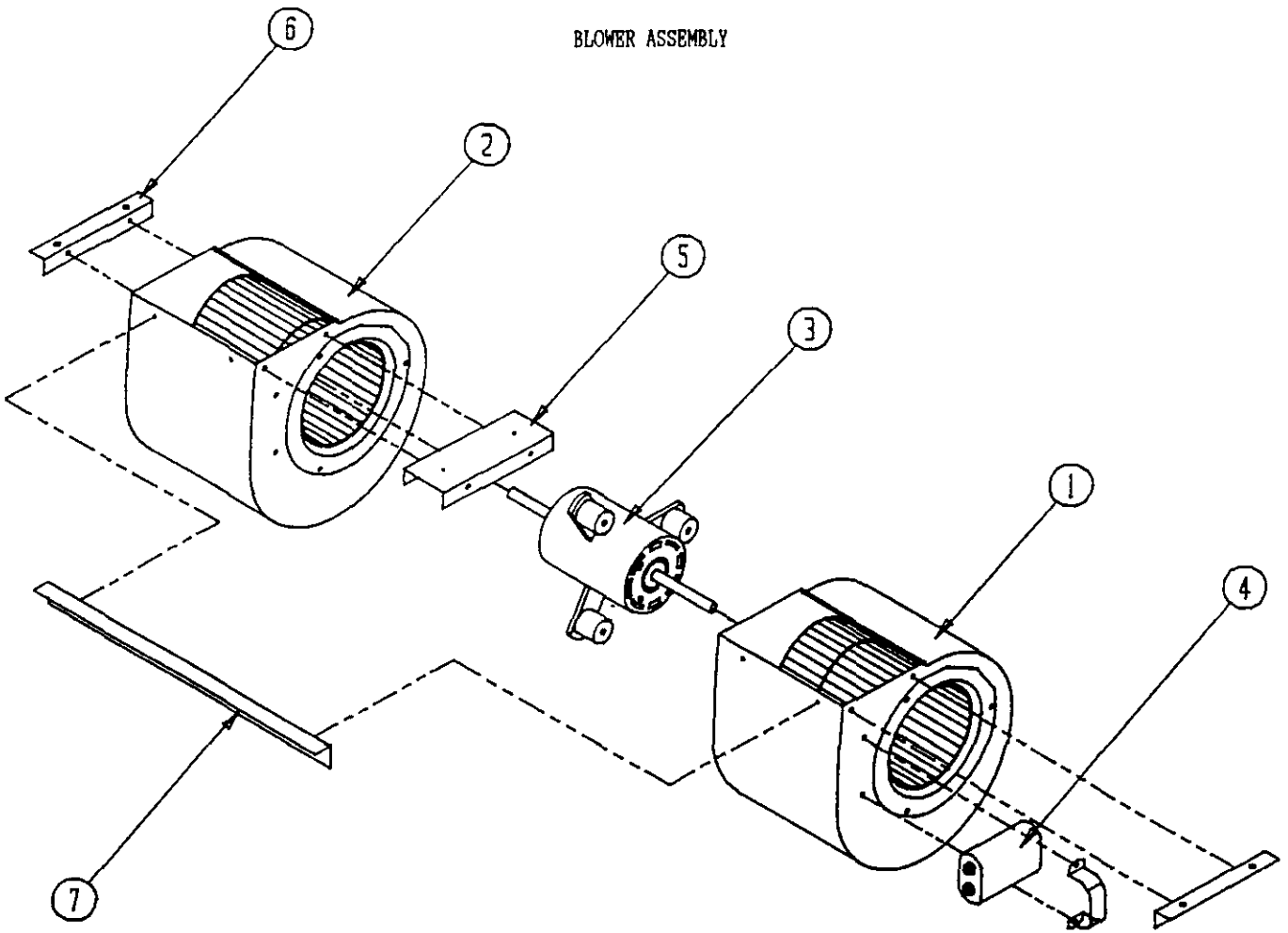

BLOWER ASSEMBLY

Dwg. No.	Part No.	Description	9	9
			0	0
			0	0
			2	2
			0	0
			0	1
1	5152-076	Housing, Wheel and Cutoff (CW) Right	x	x
2	5152-077	Housing, Wheel and Cutoff (CCW) Left	x	x
3	8101-009	Blower Motor (230/208)	x	
3	8101-010	Blower Motor (115)		x
4	8552-001	Capacitor 4MFD	x	
4	8552-002	Capacitor 5MFD		x
5	141-203	Center Blower Support	x	x
6	105-908	Side Angle	2	2
7	105-902	Front Brace	x	x

Date: 3-01-94  
Supersedes: 7-22-93