

REPLACEMENT PARTS MANUAL

WALL MOUNTED PACKAGE AIR CONDITIONER MODELS: WA181, WA241

Manual 2110-410

Revision A

Date 9-01-92

Supersedes 6-05-92

* GENERAL NOTES *

*Revised and/or additional pages may be issued from time to time.
*A complete and current manual consists of pages dated as shown in the following index.

** INDEX **

<u>Page Description</u>	<u>Page</u>	<u>Date</u>	<u>Supersedes</u>
Cabinet Components--Exploded View	1	9-01-92	6-05-92
" " --Usage List	2	9-01-92	6-05-92
Functional Components--Exploded View	3	6-05-92	
" " --Usage List	4	9-01-92	6-05-92
Control Panel--Layout	5	6-05-92	
" " --Usage List	6	6-05-92	
Blower Assembly--Exploded View, Usage List	7	6-05-92	

*** IMPORTANT ***

Contact the installing and/or local Bard distributor for all parts requirements. Make sure you have the complete model and serial number available from the unit rating plate.

CABINET COMPONENTS

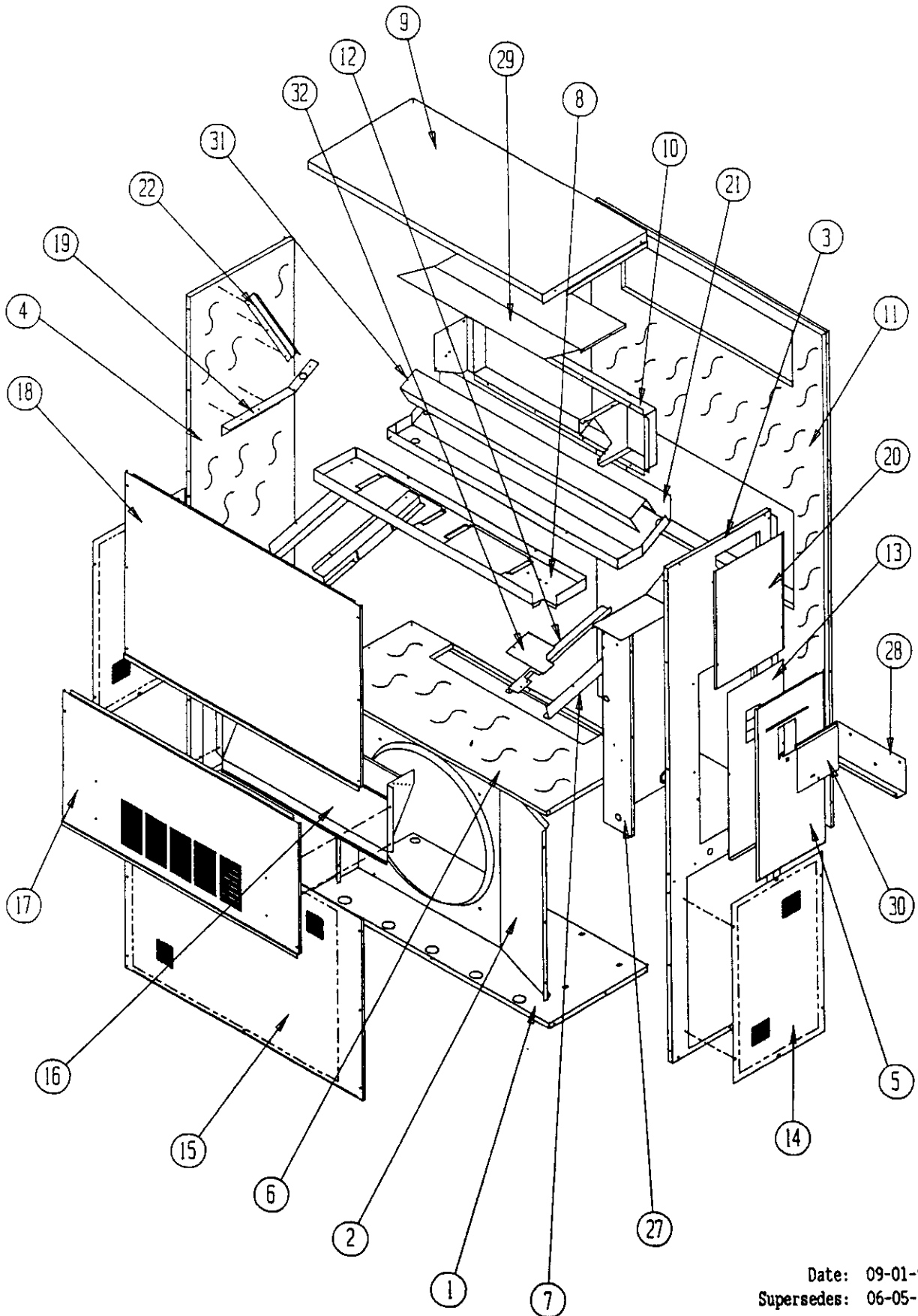

Date: 09-01-92
Supersedes: 06-05-92

CABINET COMPONENTS

Dwg. No.	Part No.	Description	W	W
			A	A
			1	2
			8	4
			1	1
			-	-
			A	A, B
1	S127-204	Lower Base	X	X
2	125-023	Fan Shroud	X	X
3	(1) S500-228-*	Right Side	X	X
4	(1) S500-229-*	Left Side	X	X
5	(1) S532-109-*	Control Panel Cover (Outer)	X	X
6	520-204	Condenser Partition	X	X
7	105-849	Filter Support Angle	2	2
8	121-190	Blower Partition	X	X
9	(1) S506-137-*	Top	X	X
10	111-032	Outlet Airframe Assembly	X	X
11	S508-097	Back	X	X
12	113-122	Filter Bracket	2	2
13	133-104	Control Panel Cover (Inner)	X	X
14	(1) 118-028-*	Side Grille	2	2
15	(1) 118-030-*	Condenser Grille	X	X
16	962019	Fresh Air Damper Assembly	X	X
17	(1) S552-213-*	Service Door	X	X
18	(1) S514-076-*	Upper Front	X	X
19	105-850	Left Side Support	X	X
20	(1) 143-034-*	Right Side Cover Plate (Outer)	X	X
21	123-080	Drain Pan	X	X
22	147-044-*	Left Evaporator Support	X	X
27	Control Panel Assembly	See Control Panel Assembly Drawing and Parts List	X	X
28	113-140	Bottom Mounting Bracket	2	2
29	135-127	Heat Shield	X	X
30	(1) S153-218-*	Disconnect Access Door	X	X
31	136-195	Bottom Evaporator Fill	X	X
32	136-170	Fill Plate	X	X

2201E
2202E
2203E

(1) NOTE: Exterior cabinet parts are manufactured with various paint color options. To insure that you receive the proper paint color, you must include the complete model and serial number of the unit for which cabinet parts are being ordered.

Date: 09-01-92
Supersedes: 06-05-92

FUNCTIONAL COMPONENTS

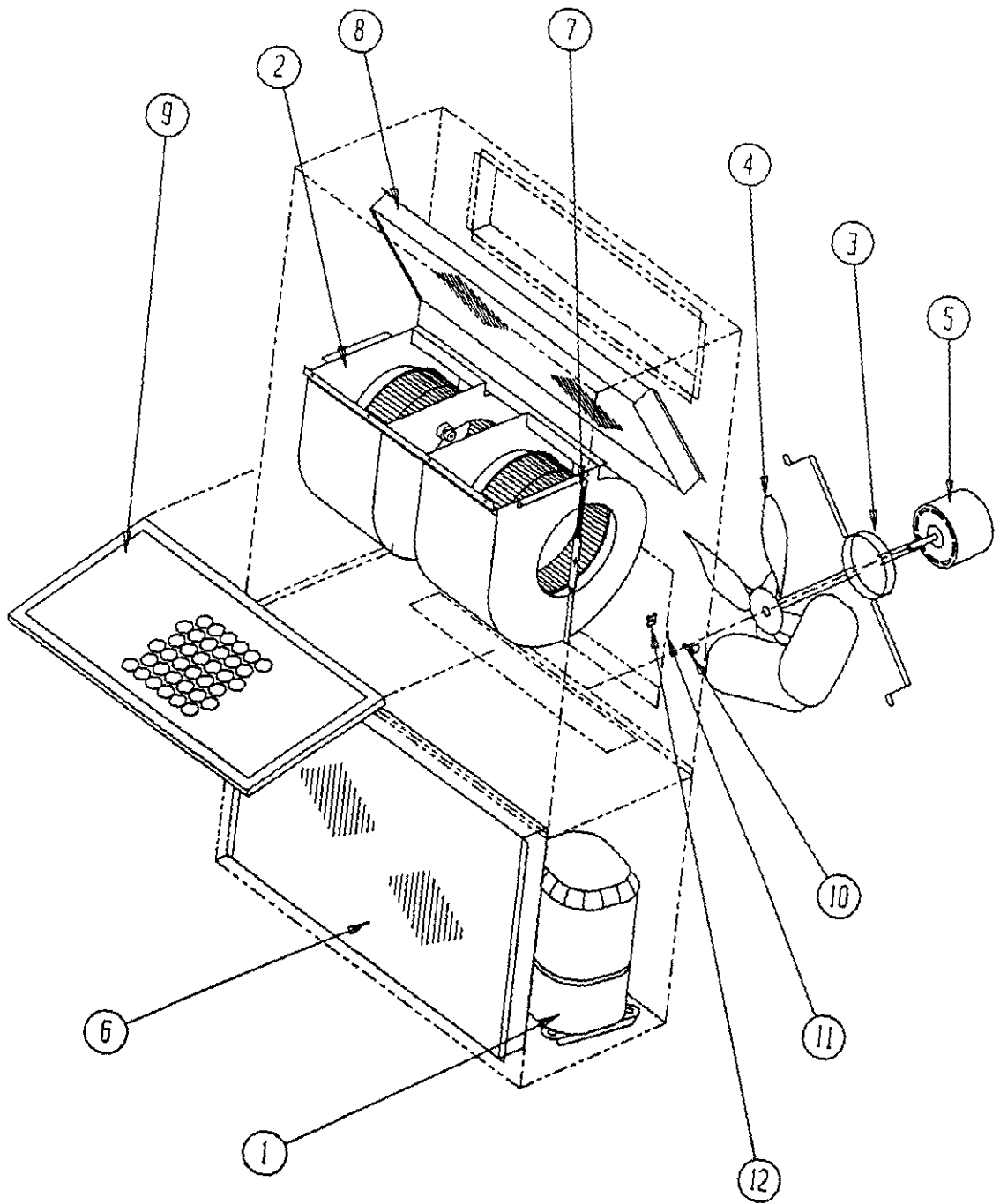

Date: 6-05-92
Supersedes:

FUNCTIONAL COMPONENTS

Dwg. No.	Part No.	Description	W	W	W
			A	A	A
			1	2	2
			8	4	4
			1	1	1
			-	-	-
			A	A	B
1	8000-141	Compressor			X
1	8000-140	Compressor		X	
1	8000-139	Compressor	X		
2	S900-181	Blower Assembly	X	X	X
3	8200-001	Fan Motor Mount	X	X	X
4	5151-033	Fan Blade	X	X	X
5	8103-016	Condenser Motor	X	X	X
6	5051-071	Condenser Coil	X	X	X
7	800-0197	Cooling Capillary Assenbly	X		
7	800-0198	Cooling Capillary Assenbly		X	X
8	5060-066	Evaporator Coil		X	X
8	5060-067	Evaporator Coil	X		
9	7004-011	Air Filter 1" Throw-Away	X	X	X
9	7003-032	Air Filter 1" Washable	X	X	X
9	7004-025	Air Filter 2" Pleated	X	X	X
10	1171-022	1/4" Turn Fastener	X	X	X
11	1171-024	1/4" Turn Retainer	X	X	X
12	1171-023	1/4" Receptacle	X	X	X
NS	8406-055	High Pressure Switch (Solder) (Optional)	X	X	X
NS	8406-061	Low Pressure Switch (Solder) (Optional)	X	X	X
NS	8406-062	Low Ambient Control (Solder) (Optional)	X	X	X
NS	1804-0106	High Pressure Switch (Flare) (Optional)	X	X	X
NS	1804-0107	Low Pressure Switch (Flare) (Optional)	X	X	X
NS	1804-0108	Low Ambient Control (Flare) (Optional)	X	X	X

NS - Not Shown

Date: 09-01-92
Supersedes: 06-05-92

CONTROL PANEL

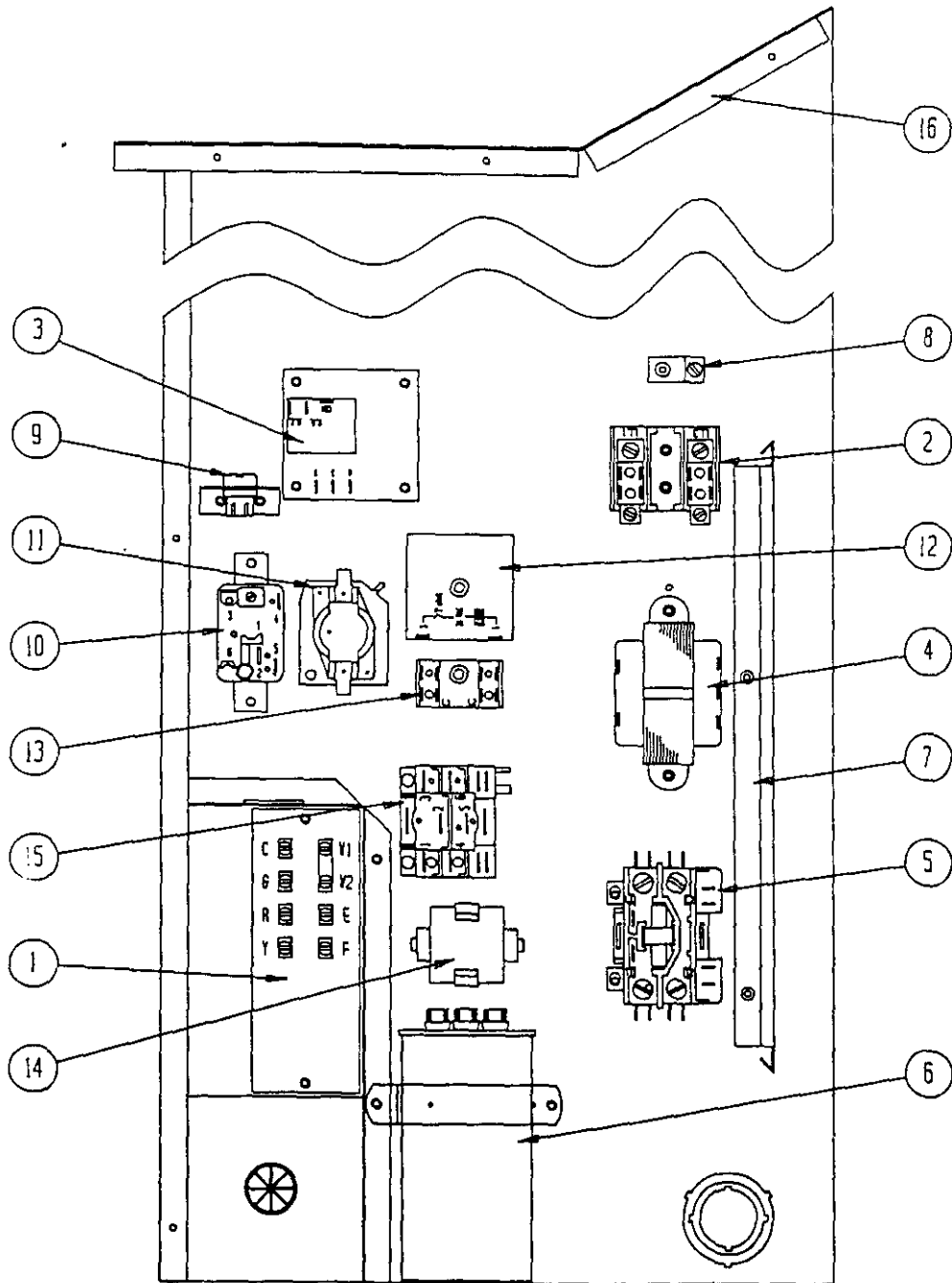

Date: 6-05-92
Supersedes:

CONTROL PANEL

Dwg. No.	Part No.	Description	W	W	W
			A	A	A
			1	2	2
			8	4	4
			1	1	1-
			-	-	-
			A	A	B
1	8607-020	Low Voltage Terminal Strip	x	x	x
2	8607-013	Terminal Block 2 Pole	x	x	
2	8607-014	Terminal Block 3 Pole			x
3	8201-056	Blower Control	x	x	
4	8407-034	Transformer	x	x	x
5	8401-007	Compressor Contactor	x	x	
5	8401-002	Compressor Contactor			x
6	8552-046	Compressor Capacitor	x		
6	8552-047	Compressor Capacitor		x	
6	8552-002	Outdoor Motor Capacitor			x
7	135-122	Wire Shield	x	x	x
8	8611-006	Ground Terminal	x	x	x
9	3000-968	6 Pin Connector	x	x	x
10	8201-038	Lockout Relay (Optional)	x	x	x
11	8201-065	Low Pressure Bypass (TDR) (Optional)	x	x	x
12	8201-050	Compressor TDR (Optional)	x	x	x
12	8201-067	Compressor TDR Adj (Optional)	x	x	x
13	8201-062	Alarm Relay (Optional)	x	x	x
13	8607-017	Terminal Block (Optional) (Shown)	x	x	x
14	8551-005	Start Device (PTCR) (Optional)	x	x	
16	117-137	Control Panel Top	x	x	x
17	117-123	Control Panel	x	x	x
	4095-110	Wiring Diagram	x		
	4095-210	Wiring Diagram		x	
	4095-310	Wiring Diagram			x

Date: 6-05-92
Supersedes:

BLOWER ASSEMBLY

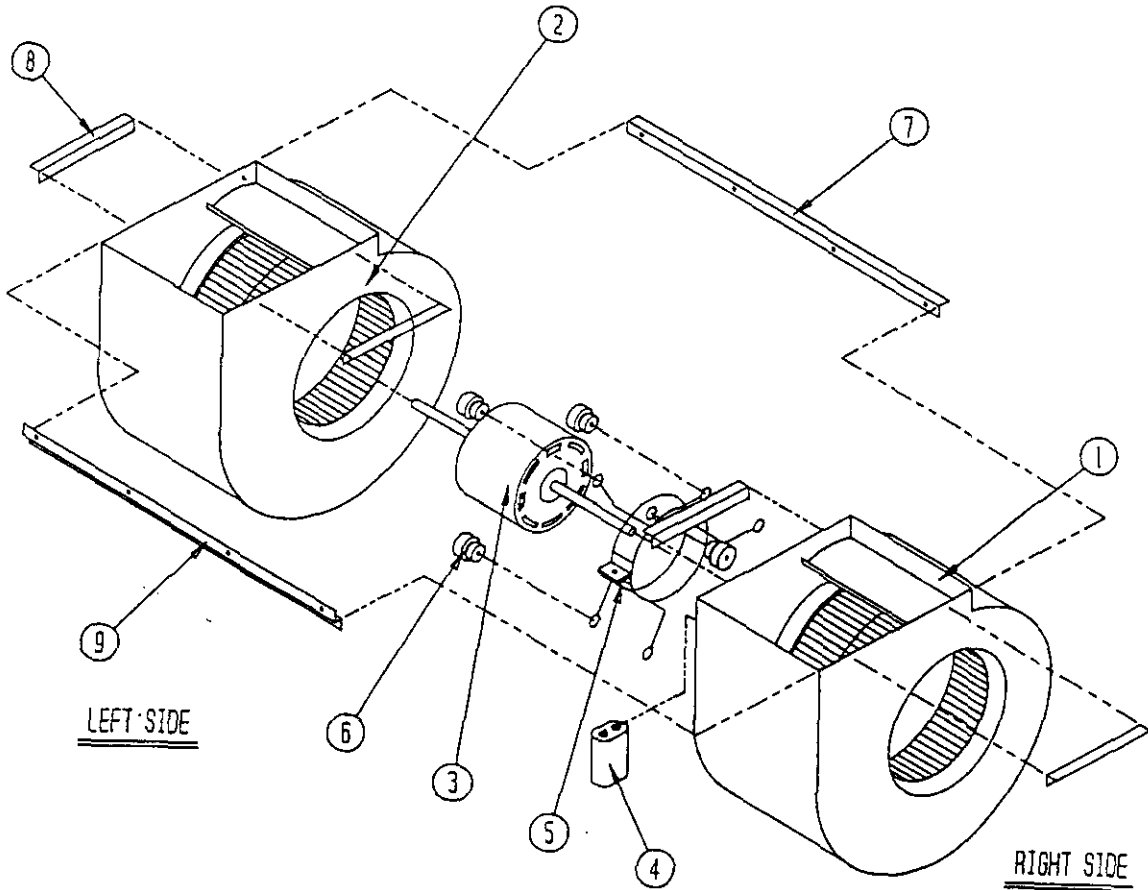

BLOWER ASSEMBLY

Dwg. No.	Part No.	Description	9	9
			0	0
			0	0
			1	1
			8	8
			1	2
1	5152-069	Housing, Wheel and Cutoff (CW)	X	X
2	5152-070	Housing, Wheel and Cutoff	X	X
3	8102-011	Blower Motor (230/208)	X	
3	8105-033	Blower Motor (460)		X
4	8552-002	Capacitor	X	X
5	8200-031	Motor Mount	X	X
6	5451-011	Grommets	6	6
7	105-869	Back Brace	X	X
8	105-868	Side Angle	4	4
9	103-400	Front Brace	X	X

Date: 6-05-92

Supersedes:

2110-410

Page: 7