

# REPLACEMENT PARTS MANUAL

WALL MOUNTED  
PACKAGE AIR CONDITIONER  
MODELS: WA301, WA361

Manual 2110-409

Revision B

Date 1-11-93

Supersedes 9-22-92

\*\*\*\*\*  
\* GENERAL NOTES \*  
\*\*\*\*\*

\*Revised and/or additional pages may be issued from time to time.  
\*A complete and current manual consists of pages dated as shown in the following index.

\*\*\*\*\*  
\*\* INDEX \*\*  
\*\*\*\*\*

<u>Page Description</u>	<u>Page</u>	<u>Date</u>	<u>Supersedes</u>
Cabinet Components--Exploded View	1	1-11-93	9-22-92
"          "--Usage List	2	1-11-93	9-22-92
Functional Components--Exploded View	3	4-02-92	
"          "--Usage List	4	1-11-93	9-22-92
Control Panel--Layout	5	9-22-92	4-02-92
"          "--Usage List	6	1-11-93	9-22-92
Blower Assembly--Exploded View, Usage List	7	1-11-93	4-02-92

\*\*\*\*\*  
\*\*\* IMPORTANT \*\*\*  
\*\*\*\*\*

Contact the installing and/or local Bard distributor for all parts requirements. Make sure you have the complete model and serial number available from the unit rating plate.

BARD MANUFACTURING COMPANY

BRYAN, OHIO 43506

CABINET COMPONENTS

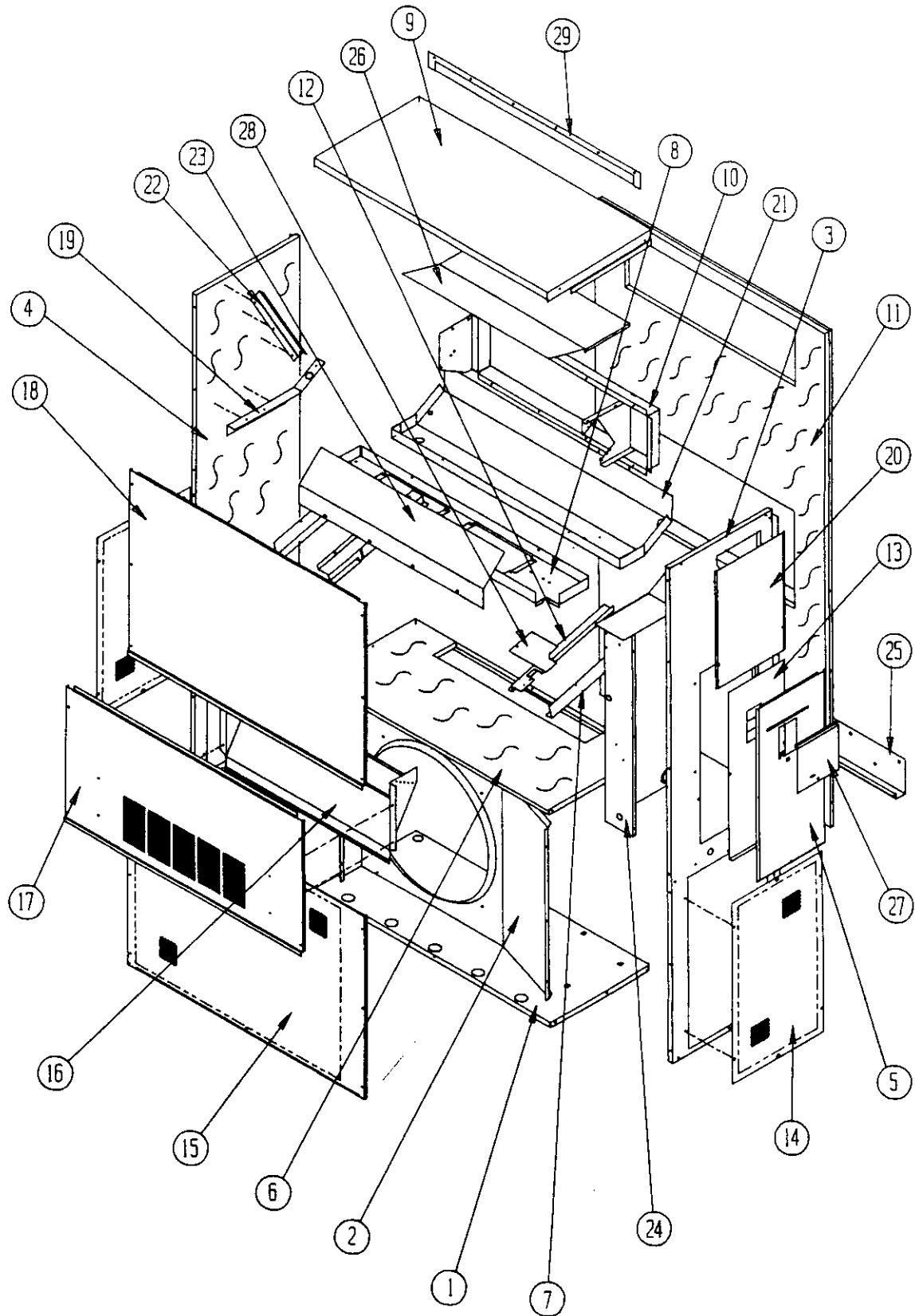

Date: 1-11-93  
Supersedes: 9-22-92

CABINET COMPONENTS

Dwg. No.	Part No.	Description	W	W	W	W
			A	A	A	A
			3	3	3	3
			0	6	0	6
			1	1	1	1
			-	-	-	-
			A.	C	A.	C
			B.		B.	
			D		D.	
					E.	
					F	
1	S127-199	Lower Base	x	x	x	x
2	125-022	Fan Shroud	x	x	x	x
3	(1) S500-228-*	Right Side	x	x	x	x
4	(1) S500-229-*	Left Side	x	x	x	x
5	(1) S533-109-*	Control Panel Cover (Outer)	x	x	x	x
6	520-181	Condenser Partition	x	x	x	x
7	105-849	Filter Support Angle	2	2	2	2
8	121-182	Blower Partition	x	x	x	x
9	(1) S506-130-*	Top	x	x	x	x
10	S111-030	Outlet Airframe Assembly	x	x	x	x
11	S508-088	Back	x	x	x	x
12	113-122	Filter Bracket Cover	2	2	2	2
13	133-104	Control Panel Cover (Inner)	x		x	
13	133-110	Control Panel Cover (Inner)		x		x
14	(1) 118-028-*	Side Grille	2	2	2	2
15	(1) 118-029-*	Condenser Grille	x	x	x	x
16	962014	Fresh Air Damper Assembly	x	x	x	x
17	(1) S552-206-*	Service Door	x	x	x	x
18	(1) S514-072-*	Upper Front	x	x	x	x
19	105-850	Left Side Support	x	x	x	x
20	(1) 143-034-*	Right Side Cover Plate (Outer)	x	x	x	x
21	S123-078	Drain Pan	x	x	x	x
22	147-044-*	Left Evaporator Support	x	x	x	x
23	135-124	Air Baffle	x	x	x	x
24	Control Panel Assembly	See Control Panel Assembly Drawing and Parts List	x	x	x	x
25	113-140	Bottom Mounting Bracket	1	1	1	1
26	135-123	Heat Shield	x	x	x	x
27	(1) S153-218-*	Disconnect Access Door	x	x	x	x
28	136-170	Fill Plate	x	x	x	x
29	(1) 113-149-*	Top Rain Flashing	x	x	x	x

(1) NOTE: Exterior cabinet parts are manufactured with various paint color options. To insure that you receive the proper paint color, you must include the complete model and serial number of the unit for which cabinet parts are being ordered.

Date: 1-11-93  
Supersedes: 9-22-92

2110-409

FUNCTIONAL COMPONENTS

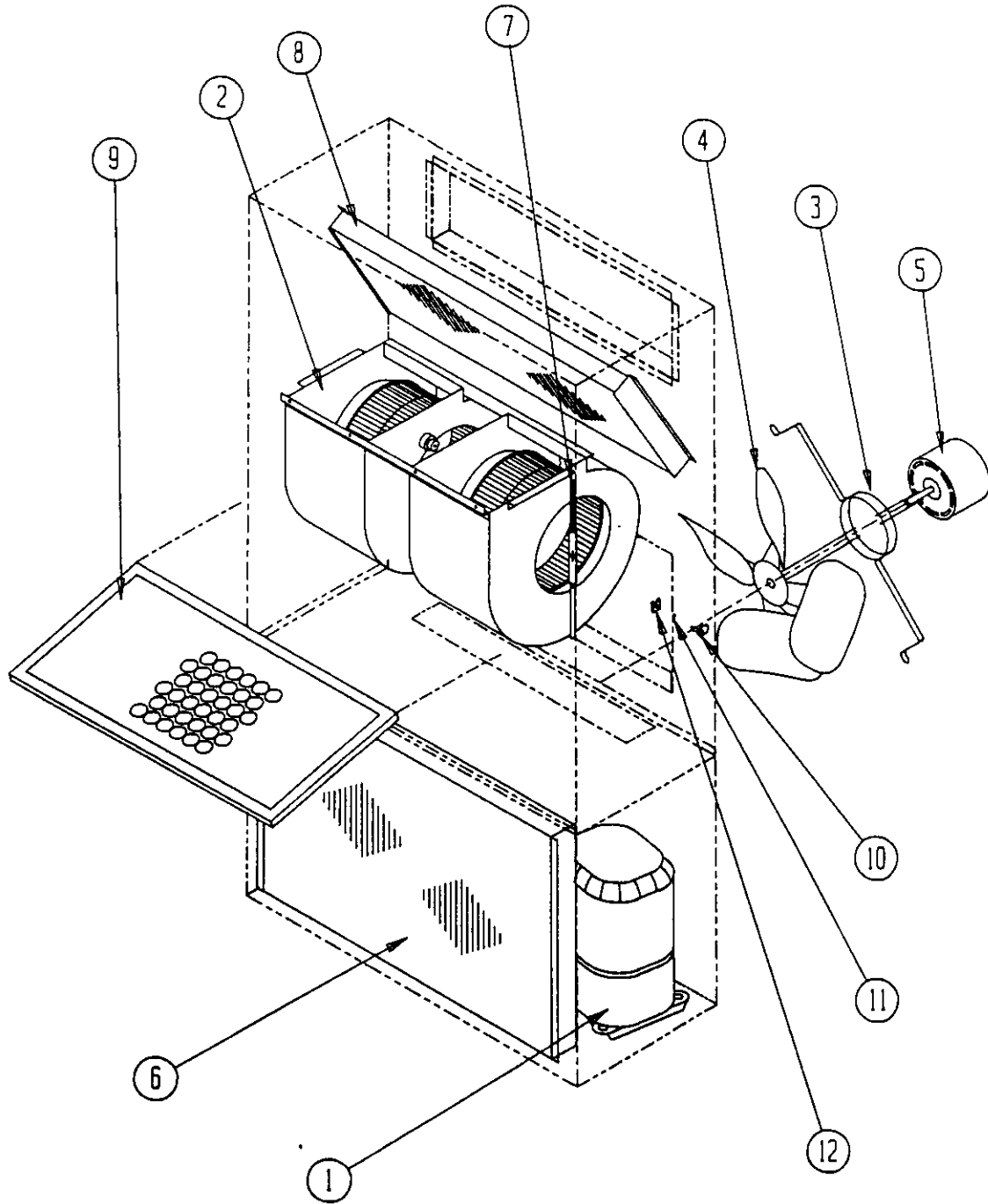

Date: 4-02-92  
Supersedes:

FUNCTIONAL COMPONENTS

Dwg. No.	Part No.	Description	W	W	W	W	W	W	W	W	W	W
			A	A	A	A	A	A	A	A	A	A
			3	3	3	3	3	3	3	3	3	3
			0	0	0	0	6	6	6	6	6	6
			1	1	1	1	1	1	1	1	1	1
			-	-	-	-	-	-	-	-	-	-
			A	B	C	D	A	B	C	D	E	F
1	8000-125	Compressor					X					
1	8000-132	Compressor	X									
1	8000-133	Compressor						X			X	
1	8000-134	Compressor							X			X
1	8000-135	Compressor		X								
1	8000-136	Compressor			X							
1	8000-144	Compressor				X						
1	8000-145	Compressor								X		
2	S900-179	Blower Assembly	X	X		X	X	X		X	X	X
2	S900-180	Blower Assembly			X				X			
3	8200-001	Fan Motor Mount	X	X	X	X	X	X	X	X	X	X
4	5151-045	Fan Blade	X	X	X	X	X	X	X			
5	8103-013	Condenser Motor	X	X		X	X	X		X	X	X
5	8103-020	Condenser Motor			X				X			
6	5051-066	Condenser Coil					X	X	X	X	X	X
6	5051-068	Condenser Coil	X	X	X	X						
7	800-0185	Cooling Capillary Assembly					X	X	X	X	X	X
7	800-0184	Cooling Capillary Assembly	X	X	X	X						
8	5060-064	Evaporator Coil	X	X	X	X	X	X	X	X	X	X
9	7004-019	Air Filter 1" Throw-Away	X	X	X	X	X	X	X	X	X	X
9	7003-031	Air Filter 1" Washable (Optional)	X	X	X	X	X	X	X	X	X	X
9	7004-026	Air Filter 2" Pleated (Optional)	X	X	X	X	X	X	X	X	X	X
10	1171-022	1/4" Turn Fastener	X	X	X	X	X	X	X	X	X	X
11	1171-024	1/4" Turn Retainer	X	X	X	X	X	X	X	X	X	X
12	1171-023	1/4" Receptacle	X	X	X	X	X	X	X	X	X	X
NS	8406-055	High Pressure Switch (Solder) (Optional)	X	X	X	X	X	X	X	X	X	X
NS	8406-061	Low Pressure Switch (Solder) (Optional)	X	X	X	X	X	X	X	X	X	X
NS	8406-062	Low Ambient Control (Solder) (Optional)	X	X	X	X	X	X	X	X	X	X
NS	1804-0106	High Pressure Switch (Flare) (Optional)	X	X	X	X	X	X	X	X	X	X
NS	1804-0107	Low Pressure Switch (Flare) (Optional)	X	X	X	X	X	X	X	X	X	X
NS	1804-0108	Low Ambient Control (Flare) (Optional)	X	X	X	X	X	X	X	X	X	X

NS - Not Shown

Date: 1-11-93  
Supersedes: 9-22-92

CONTROL PANEL

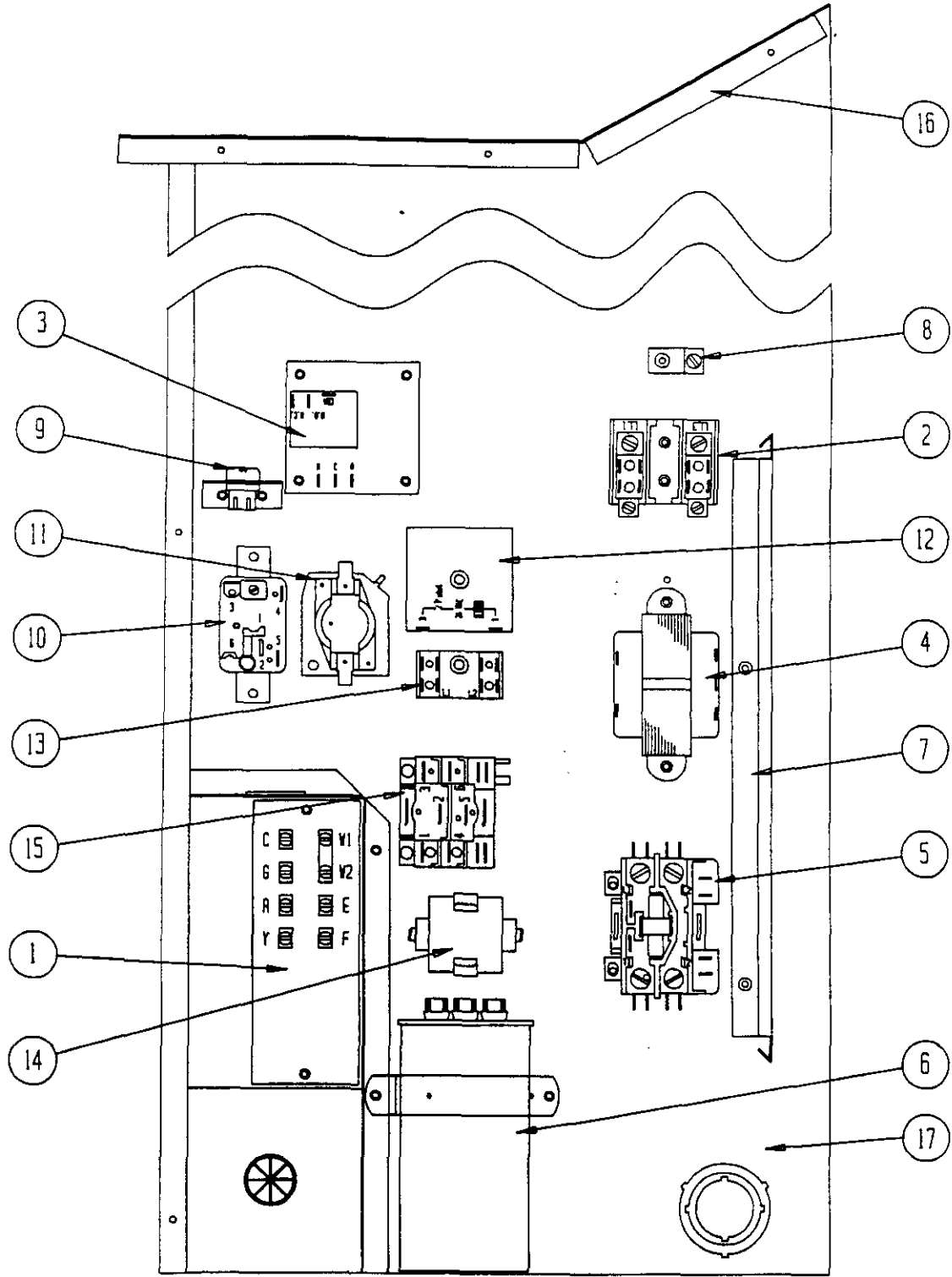

Date: 9-22-92  
Supersedes: 4-02-92

CONTROL PANEL

Dwg. No.	Part No.	Description	W	W	W	W	W	W	W	W	W	W
			A	A	A	A	A	A	A	A	A	A
			3	3	3	3	3	3	3	3	3	3
			0	0	0	0	6	6	6	6	6	6
			1	1	1	1	1	1	1	1	1	1
			-	-	-	-	-	-	-	-	-	-
			A	B	C	D	A	B	C	D	E	F
1	8607-020	Low Voltage Terminal Strip	X	X	X	X	X	X	X	X	X	X
2	8607-013	Terminal Block 2 Pole	X			X	X			X		2
2	8607-014	Terminal Block 3 Pole		X	X			X	X		X	
2	8607-015	Phelon Insulator			X				X			
3	8201-056	Blower Control	X	X		X	X	X		X	X	X
3	8201-032	Blower Relay			X				X			
4	8407-034	Transformer	X	X		X	X	X		X	X	X
4	8407-042	Transformer			X				X			
5	8401-007	Compressor Contactor	X			X	X			X		
5	8401-002	Compressor Contactor		X	X			X	X		X	X
6	8552-048	Compressor Capacitor	X			X						
6	8552-050	Compressor Capacitor					X			X		
6	8552-002	Outdoor Motor Capacitor		X	X			X	X		X	X
7	135-122	Wire Shield	X	X	X	X	X	X	X	X	X	X
8	8611-006	Ground Terminal	X	X	X	X	X	X	X	X	X	X
9	3000-968	6 Pin Connector	X	X	X	X	X	X	X	X	X	X
10	8201-034	Lockout Relay (Optional)	X	X	X	X	X	X	X	X	X	X
11	8201-065	Low Pressure Bypass (TDR) (Optional)	X	X	X	X	X	X	X	X	X	X
12	8201-050	Compressor TDR (Optional)	X	X	X	X	X	X	X	X	X	X
12	8201-067	Compressor TDR Adj (Optional)	X	X	X	X	X	X	X	X	X	X
13	8201-062	Alarm Relay (Optional)	X	X	X	X	X	X	X	X	X	X
13	8607-017	Terminal Block (Optional) (Shown)	X	X		X	X	X		X	X	X
14	8551-005	Start Device (PTCR) (Optional)	X			X	X			X		
15	8201-032	Outdoor Fan Relay (Optional)			X				X			
16	117-137	Control Panel Top	X	X	X	X	X	X	X	X	X	X
17	117-123	Control Panel	X	X	X	X	X	X	X	X	X	X
	4095-110	Wiring Diagram	X			X	X			X		
	4095-210	Wiring Diagram		X				X			X	
	4095-310	Wiring Diagram			X				X			
	4095-610	Wiring Diagram										X

Date: 1-11-93  
Supersedes: 9-22-92

BLOWER ASSEMBLY

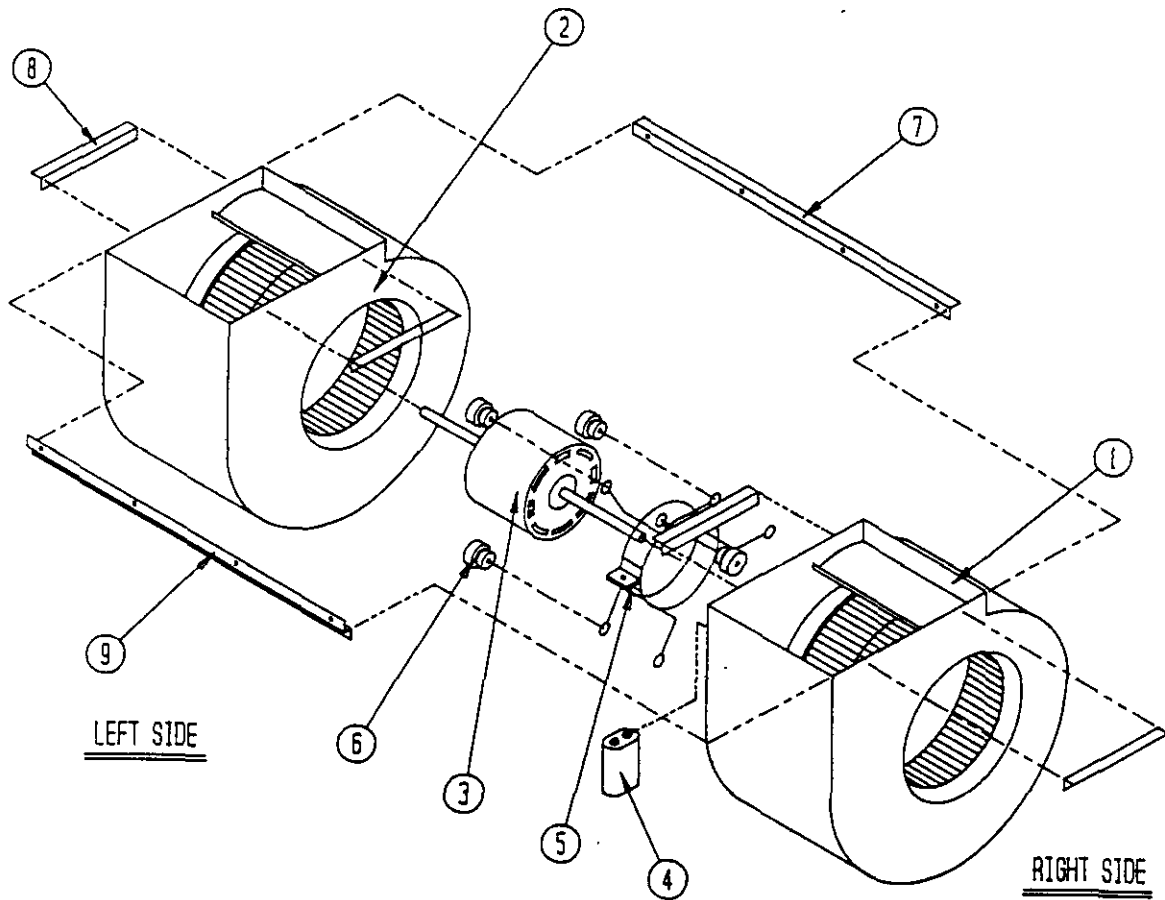

BLOWER ASSEMBLY

Dwg. No.	Part No.	Description	9	9
			0	0
			0	0
			1	1
			7	8
			9	0
1	5152-051	Housing, Wheel and Cutoff (CW)	X	X
2	5152-052	Housing, Wheel and Cutoff	X	X
3	8105-029	Blower Motor (230/208)	X	
3	8105-033	Blower Motor (460)		X
4	8552-002	Capacitor	X	X
5	8200-031	Motor Mount	X	X
6	5451-011	Grommets	6	6
7	105-870	Back Brace	X	X
8	104-868	Side Angle	4	4
9	103-401	Front Brace	X	X

Date: 1-11-93  
Supersedes: 4-02-92