

REPLACEMENT PARTS MANUAL

WALL MOUNTED PACKAGE AIR CONDITIONER MODEL 49WA

Manual 2110-406

Revision --

Date 7-11-89

Supersedes

* GENERAL NOTES *

*Revised and/or additional pages may be issued from time to time.
*A complete and current manual consists of pages dated as shown in the following index.

** INDEX **

<u>Page Description</u>	<u>Page</u>	<u>Date</u>	<u>Supersedes</u>
Cabinet Components--Exploded View	1	7-11-89	
" " --Usage List	2	7-11-89	
Functional Components--Exploded View	3	7-11-89	
" " --Usage List	4	7-11-89	
Functional Components--Exploded View	5	7-11-89	
" " --Usage List	6	7-11-89	
Functional Components--Exploded View	7	7-11-89	
" " --Usage List	8	7-11-89	
Control Panel W/O Circuit Breaker--Layout	9	7-11-89	
" " " " " --Usage List	10	7-11-89	
Control Panel W/O Circuit Breaker--Layout	11	7-11-89	
" " " " " --Usage List	12	7-11-89	
Control Panel W/Circuit Breaker--Layout	13	7-11-89	
" " " " " --Usage List	14	7-11-89	
Blower Assembly--Exploded View	15	7-11-89	
" " --Usage List	16	7-11-89	

*** IMPORTANT ***

Contact the installing and/or local Bard distributor for all parts requirements. Make sure you have the complete model and serial number available from the unit rating plate.

CABINET COMPONENTS

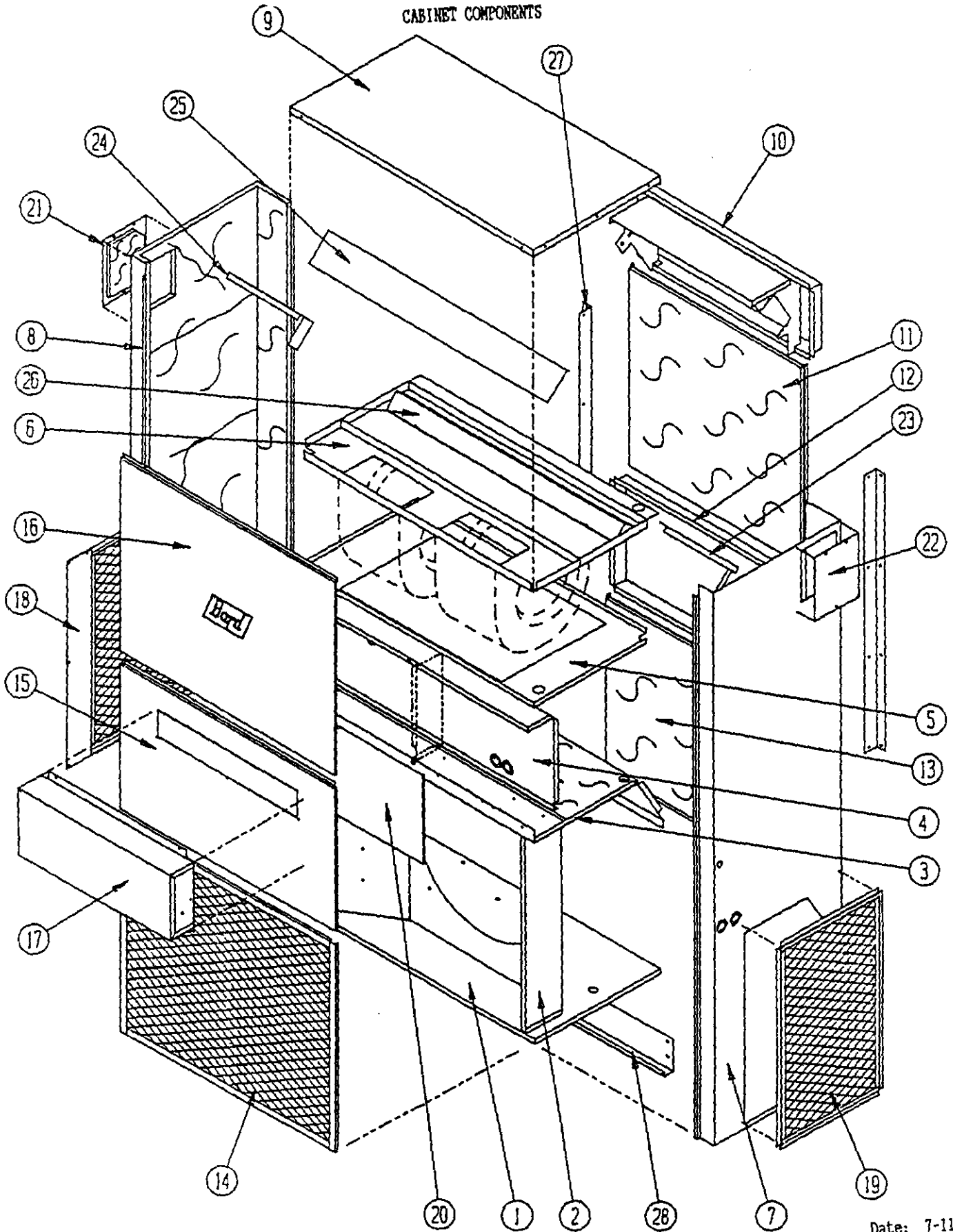

Date: 7-11-89
Supersedes:

CABINET COMPONENTS

Item	Part No.	Description	U S A G E
1	127-005	Lower Base	X
2	124-003	Fan Shroud	X
3	520-133	Condenser Partition	X
4	Control Pnl. Assy.	See Control Panel Assembly Drawing and Parts List	X
5	131-004	Filter Tray	X
6	521-006	Water Pan/Blower Partition	X
7	501-168	Right Side	X
8	501-169	Left Side	X
9	506-097	Top	X
10	111-019	Outlet Airframe Assembly	X
11	508-059	Upper Back	X
12	111-020	Inlet Air Frame Assembly	X
13	508-060	Lower Back	X
14	119-005	Coil Grille	X
15	552-108	Service Door	X
16	514-047	Upper Front	X
17	FAD25	Fresh Air Damper	X
18	119-006	Left Side Grille	X
19	119-008	Right Side Grille	X
20	Control Cover	See Control Panel Assembly Drawing and Parts List	X
21	542Y005	Left Side Cover Plate	X
22	542X005	Right Side Cover Plate	X
23	140-010	Support--Right Coil	X
24	140-011	Support--Left Coil	X
25	134-011	Top Evaporator Fill	X
26	137-003	Bottom Evaporator Fill	X
27	112-009	Side Mounting Bracket	X
28	112-006	Bottom Mounting Bracker	X

Date: 7-11-89
Supersedes:

FUNCTIONAL COMPONENTS

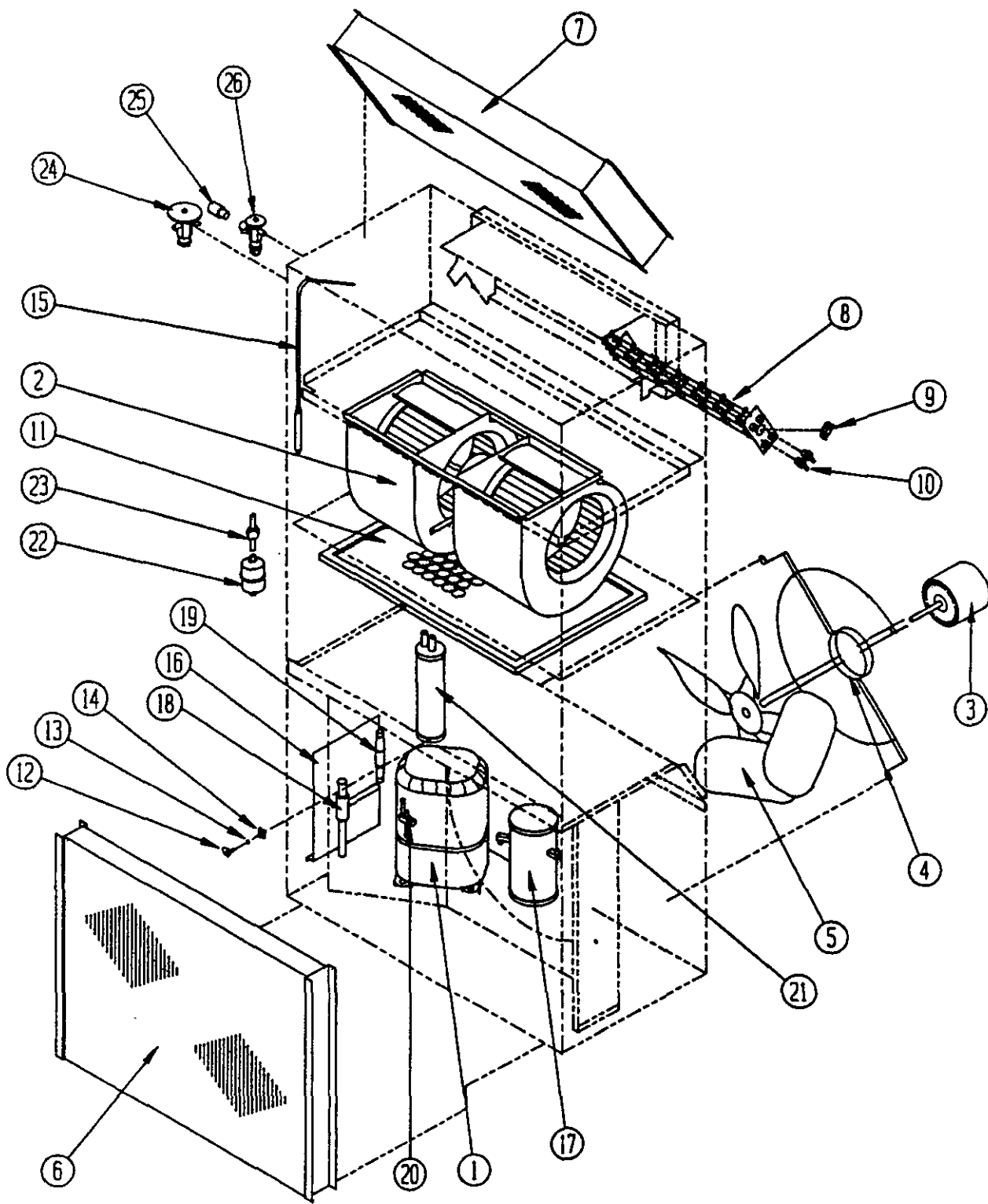

Date: 7-11-89
Supersedes:

FUNCTIONAL COMPONENTS

Dwg. No.	Part No.	Description	4 9 W A A O O N, C	4 9 W A A O O N, C	4 9 W A A O O N, C	4 9 W A A O O N, C	4 9 W A B O O N, C	4 9 W A B O O N, C	4 9 W A B O O N, C	4 9 W A B O O N, C	4 9 W A C O O N, C	4 9 W A C O O N, C	4 9 W A C O O N, C
1	8000-063	Compressor CRK3-0325-PFV	X	X	X	X							
1	8000-064	Compressor CRK3-0325-TF5					X	X	X	X			
1	8000-065	Compressor CRK3-0325-TFD									X	X	X
2	900-119	Blower Assembly (Complete)	X	X	X	X	X	X	X	X			
2	900-120	Blower Assembly (Complete)									X	X	X
3	8105-035	Condenser Motor	X	X	X	X	X	X	X	X			
3	8105-030	Condenser Motor									X	X	X
4	8200-004	Motor Mount--Condenser	X	X	X	X	X	X	X	X	X	X	X
5	5151-027	Fan Blade	X	X	X	X	X	X	X	X	X	X	X
6	5051-028	Condenser Coil	X	X	X	X	X	X	X	X	X	X	X
7	5060-025	Evaporator Coil	X	X	X	X	X	X	X	X	X	X	X
8	8604-091	Heat Strip		X		2							
8	8604-047	Heat Strip			X			X					
8	8604-048	Heat Strip					X		X				
8	8604-072	Heat Strip										X	
8	8604-052	Heat Strip											X
9	8402-047	Limit Control		X	X	X		X	X	X			X
10	8402-032	Thermal Cutoff 4K9239H		2	3	4		2	3	4			
10	8402-057	Thermal Cutoff 4K4218AH										2	3
11	7004-016	Air Filter 20 x 30 x 1	X	X	X	X	X	X	X	X	X	X	X
12	1171-019	1/4 Turn Fastener	X	X	X	X	X	X	X	X	X	X	X
13	1171-021	Retainer Washer	X	X	X	X	X	X	X	X	X	X	X
14	1171-020	Receptacle	X	X	X	X	X	X	X	X	X	X	X
15	800-0093	Cooling Capillary Assembly	X	X	X	X	X	X	X	X	X	X	X

Date: 7-11-89
Supersedes:

FUNCTIONAL COMPONENTS

Dwg. No.	Part No.	Description	49WA-1A00H	49WA-1A01H	49WA-1A02H	49WA-1B00H	49WA-1B09H	49WA-1B08H	49WA-1C00H	49WA-1C09H	49WA-1C15H
1	8000-063	Compressor CRK3-0325-PFV	X	X	X						
1	8000-064	Compressor CRK3-0325-TF5				X	X	X			
1	8000-065	Compressor CRK3-0325-TFD							X	X	X
2	900-119	Blower Assembly (Complete)	X	X	X	X	X	X			
2	900-120	Blower Assembly (Complete)							X	X	X
3	8105-035	Condenser Motor	X	X	X	X	X	X			
3	8105-030	Condenser Motor							X	X	X
4	8200-004	Motor Mount--Condenser	X	X	X	X	X	X	X	X	X
5	5151-027	Fan Blade	X	X	X	X	X	X	X	X	X
6	5051-028	Condenser Coil	X	X	X	X	X	X	X	X	X
7	5060-025	Evaporator Coil	X	X	X	X	X	X	X	X	X
8	8604-091	Heat Strip		X	2						
8	8604-048	Heat Strip					X	X			
8	8604-072	Heat Strip								X	
8	8604-052	Heat Strip									X
9	8402-047	Limit Control		X	X		X	X		X	X
10	8402-032	Thermal Cutoff 4X9239H		2	4		2	4			
10	8402-057	Thermal Cutoff 4X4218AH								2	3
11	7004-016	Air Filter 20 x 30 x 1	X	X	X	X	X	X	X	X	X
12	1171-019	1/4 Turn Fastener	X	X	X	X	X	X	X	X	X
13	1171-021	Retainer Washer	X	X	X	X	X	X	X	X	X
14	1171-020	Receptacle	X	X	X	X	X	X	X	X	X
15	800-0093	Cooling Capillary Assembly	X	X	X	X	X	X	X	X	X
16	---	Wire Shield									
17	5203-006	Receiver	X	X	X	X	X	X	X	X	X
18	5651-015	Head Pressure Control Valve	X	X	X	X	X	X	X	X	X
19	5651-016	Pressure Differential Valve	X	X	X	X	X	X	X	X	X
20	5651-051	Shutoff Valve	X	X	X	X	X	X	X	X	X
21	5202-018	Accumulator	X	X	X	X	X	X	X	X	X
22	5201-002	Filter Drier	X	X	X	X	X	X	X	X	X
23	5201-014	Sight Glass	X	X	X	X	X	X	X	X	X
24	5651-064	Hot Gas Bypass Valve	X	X	X	X	X	X	X	X	X
25	5651-008	Distributor	X	X	X	X	X	X	X	X	X
26	5651-040	Expansion Valve	X	X	X	X	X	X	X	X	X

Date: 7-11-89
Supersedes:

FUNCTIONAL COMPONENTS

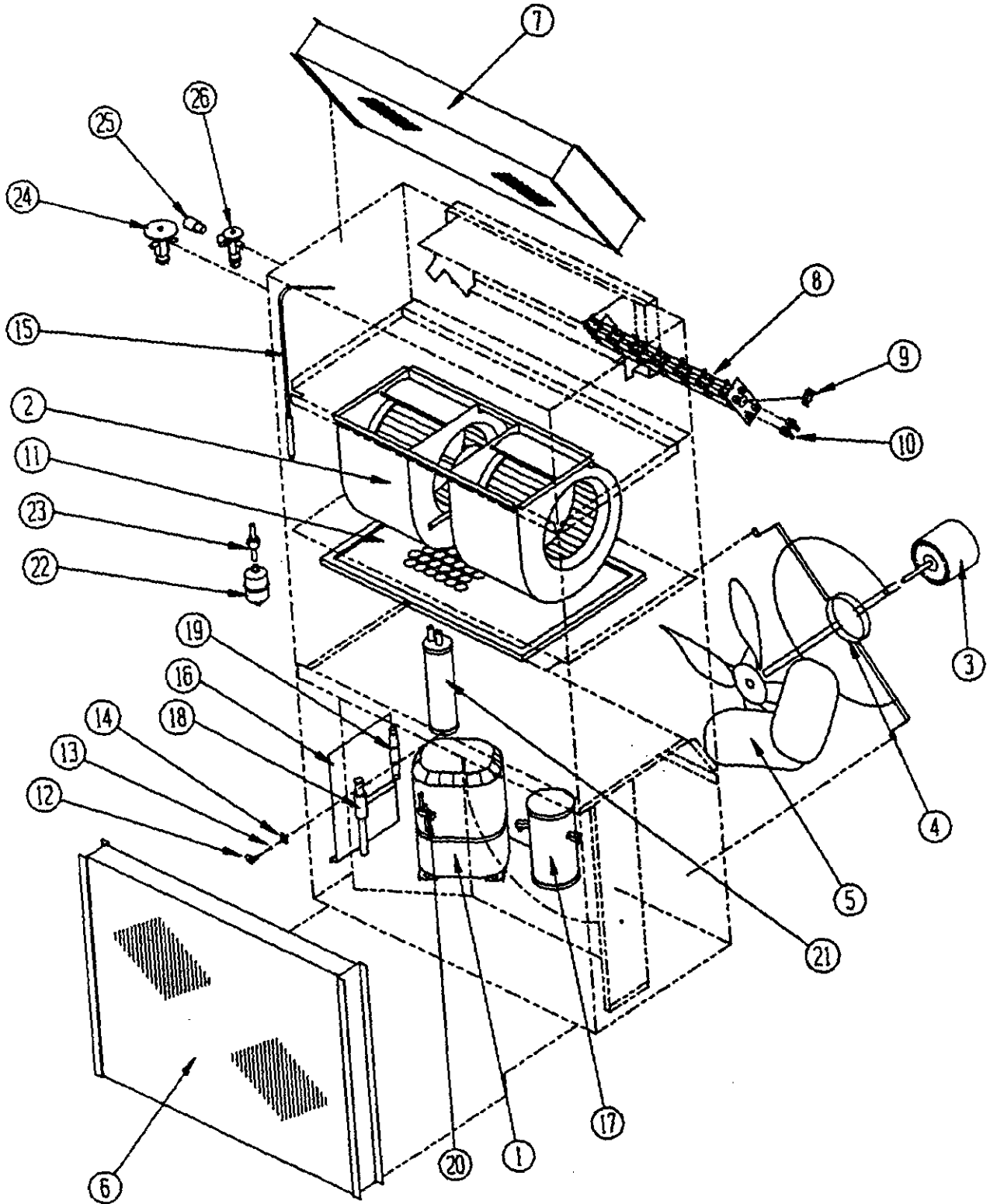

Date: 7-11-89
Supersedes:

FUNCTIONAL COMPONENTS

Dwg. No.	Part No.	Description	4 9 W A E O O N	4 9 W A E 1 5 N	4 9 W A F O N	4 9 W A F 1 4 N	4 9 W A G O N	4 9 W A G 1 5 N
1	8000-026	Compressor					X	X
1	8000-064	Compressor	X	X				
1	8000-065	Compressor			X	X		
2	900-119	Blower Assembly (Complete)	X	X	X	X	X	X
3	8105-014	Condenser Motor	X	X	X	X	X	X
4	8200-004	Motor Mount--Condenser	X	X	X	X	X	X
5	5151-026	Fan Blade	X	X	X	X	X	X
6	5051-028	Condenser Coil	X	X	X	X	X	X
7	5060-025	Evaporator Coil	X	X	X	X	X	X
8	8604-087	Heat Strip				X		
8	8604-047	Heat Strip		X				X
9	8402-047	Limit Control		X		X		X
10	8402-032	Thermal Cutoff 4K9239H		3		4		3
11	7004-016	Air Filter 20 x 30 x 1	X	X	X	X	X	X
12	1171-019	1/4 Turn Fastener	X	X	X	X	X	X
13	1171-021	Retainer Washer	X	X	X	X	X	X
14	1171-020	Receptacle	X	X	X	X	X	X
15	800-0093	Cooling Capillary Assembly	X	X	X	X	X	X

Date: 7-11-89
Supersedes:

CONTROL PANEL WITHOUT CIRCUIT BREAKER

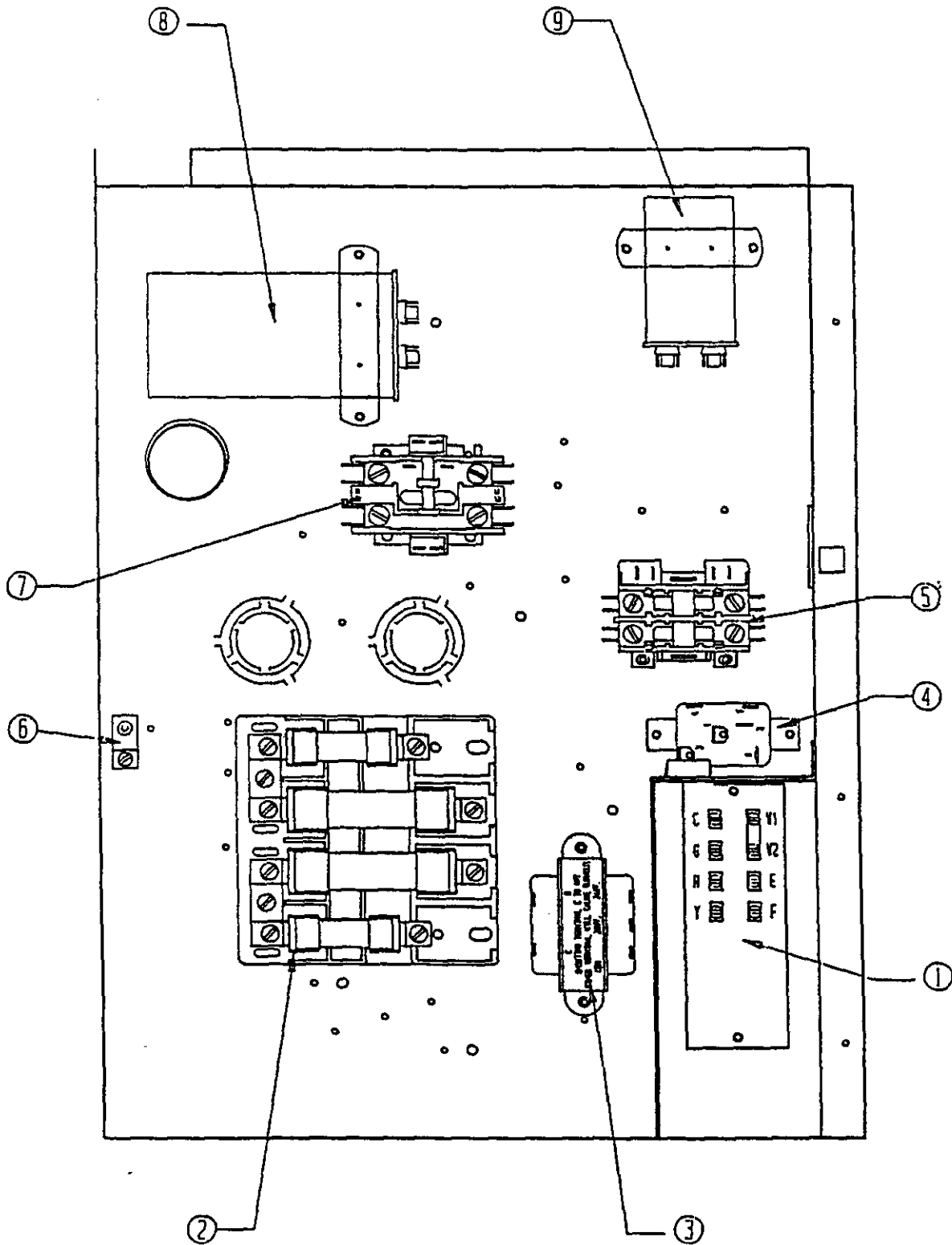

Date: 7-11-89
Supersedes:

CONTROL PANEL
WITHOUT CIRCUIT BREAKER

Dwg. No.	Part No.	Description	4 9 W A A O O N, H	4 9 W A A O O N, H	4 9 W A A I 5 N, H	4 9 W A A 2 O N, H	4 9 W A B O O N, H	4 9 W A B O O N, H	4 9 W A B 1 5 N, H	4 9 W A B 1 8 N, H	4 9 W A C O O N, H	4 9 W A C O O N, H	4 9 W A C I 5 N, H
1	8607-018	Low Voltage Strip	X	X	X	X	X	X	X	X	X	X	X
2	8607-013	Terminal Block	X	X									
2	8607-014	Terminal Block					X	X	X	X	X	X	X
2	8614-017	Fuse Block			X								
2	8614-018	Fuse Block				X							
3	8407-034	Transformer	X	X	X	X	X	X	X	X			
3	8407-027	Transformer									X	X	X
4	8201-009	Blower Relay	X	X	X	X	X	X	X	X			
4	8201-032	Blower Relay									X	X	X
5	8401-006	Heat Contactor		X	2	2		X	2	2			
5	8401-002	Heat Contactor											
6	8611-006	Ground Terminal	X	X	X	X	X	X	X	X	X	X	X
7	8401-003	Compressor Contactor	X	X	X	X							
7	8401-002	Compressor Contactor					X	X	X	X	X	X	X
8	8552-030	Compressor Capacitor 40/440	X	X	X	X							
9	8552-005	Condenser Fan Capacitor 10/370					X	X	X	X	X	X	X
9	8552-026	Condenser Fan Capacitor 15/370									X	X	X
10	8607-015	Phenolic Insulator									X	X	X
	4010-110	Wiring Diagram	X										
	4010-130	Wiring Diagram		X									
	4010-140	Wiring Diagram			X								
	4010-150	Wiring Diagram				X							
	4010-210	Wiring Diagram					X						
	4010-220	Wiring Diagram						X					
	4010-230	Wiring Diagram							X				
	4010-240	Wiring Diagram								X			
	4010-310	Wiring Diagram									X		
	4010-320	Wiring Diagram										X	
	4010-330	Wiring Diagram											X
	132-081	Control Panel Cover	X	X			X	X	X	X	X	X	X
	133-054	Control Panel Cover			X	X							

Date: 7-11-89
Supersedes:

CONTROL PANEL WITHOUT CIRCUIT BREAKER

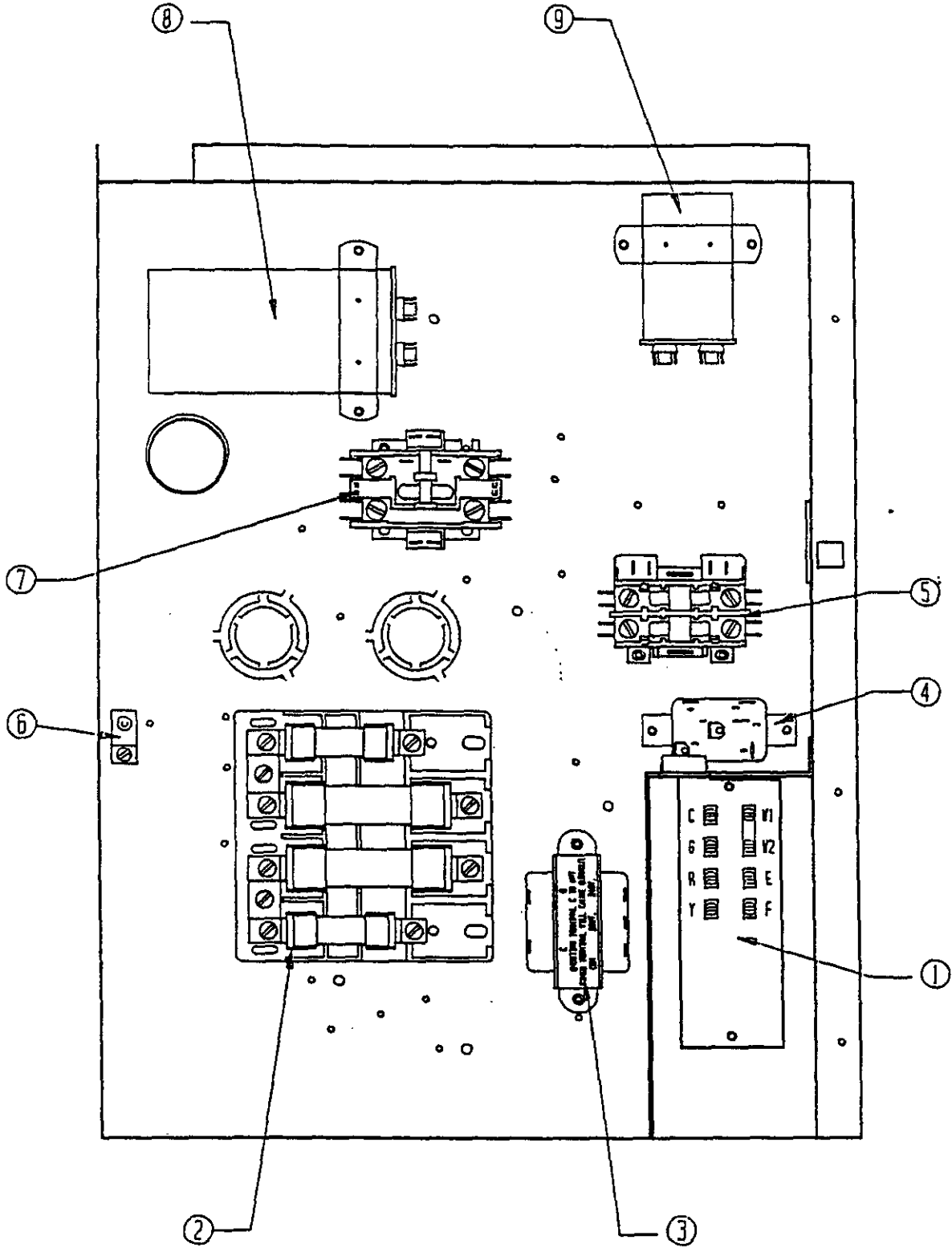

Date: 7-11-89
Supersedes:

CONTROL PANEL
WITHOUT CIRCUIT BREAKER

Dwg. No.	Part No.	Description	4 9 W A E O O N	4 9 W A E 1 5 N	4 9 W A F O O N	4 9 W A F 1 4 N	4 9 W A G O O N	4 9 W A G 1 5 N
1	8607-018	Low Voltage Strip	X	X	X	X	X	X
2	8607-013	Terminal Block			2	2	X	
2	8607-014	Terminal Block	X	X				
2	8614-017	Fuse Block						X
3	8407-034	Transformer	X	X	X	X	X	X
4	8201-009	Blower Relay	X	X	X	X	X	X
5	8401-006	Heat Contactor		2				2
5	8401-002	Heat Contactor				2		
6	8611-006	Ground Terminal	X	X	X	X	X	X
7	8401-016	Compressor Contactor					X	X
7	8401-002	Compressor Contactor	X	X	X	X		
8	8552-030	Compressor Capacitor 40/440					X	X
9	8552-005	Condenser Fan Capacitor 10/370	X	X	X	X	X	X
10	---							
	4010-410	Wiring Diagram					X	
	4010-440	Wiring Diagram						X
	4010-510	Wiring Diagram	X					
	4010-530	Wiring Diagram		X				
	4010-610	Wiring Diagram			X			
	4010-630	Wiring Diagram				X		
	132-081	Control Panel Cover	X	X	X	X	X	
	133-054	Control Panel Cover						X

Date: 7-11-89
Supersedes:

CONTROL PANEL WITH CIRCUIT BREAKER

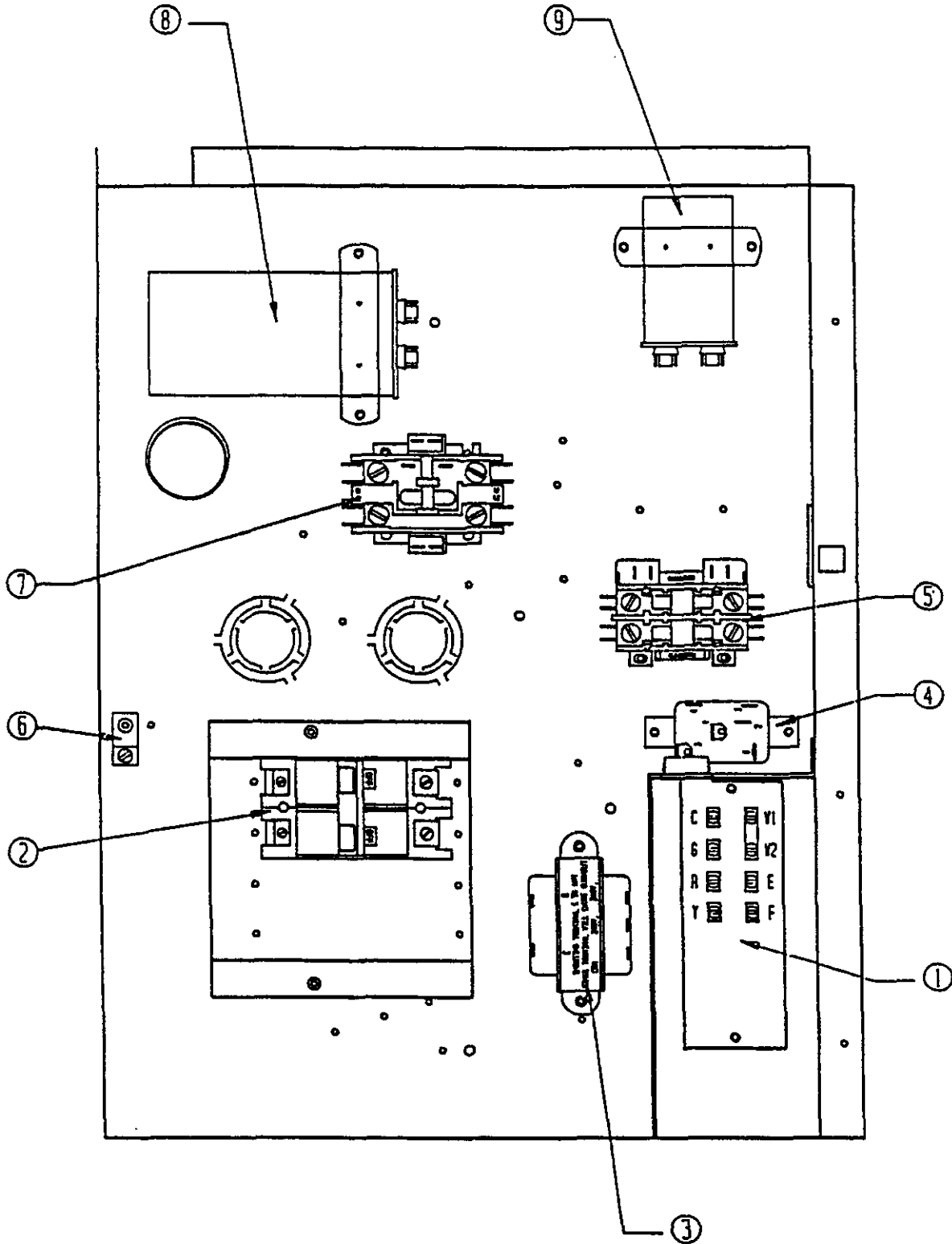

Date: 7-11-89
Supersedes:

CONTROL PANEL
WITH CIRCUIT BREAKER

Dwg. No.	Part No.	Description	49WA	49WA	49WA	49WA	49WA	49WA	49WA	49WA	49WA	49WA	49WA
			A	A	A	A	B	B	B	B	C	C	C
			O	1	1	2	0	0	1	1	0	0	1
			C	C	C	C	C	C	C	C	C	C	C
1	8607-018	Low Voltage Terminal Strip	X	X	X	X	X	X	X	X	X	X	X
2	8615-015	Circuit Breaker 50A	X										
2	8615-016	Circuit Breaker 60A		X	X	2							
2	8615-016	Circuit Breaker 30A			X								
2	8615-019	Circuit Breaker 35A					X	X					
2	8615-011	Circuit Breaker 60A							X	X			
2	8615-030	Circuit Breaker 20A									X	X	
2	8615-032	Circuit Breaker 30A											X
3	8407-034	Transformer	X	X	X	X	X	X	X	X			
3	8407-027	Transformer									X	X	X
4	8201-009	Blower Relay	X	X	X	X	X	X	X	X			
4	8201-032	Blower Relay									X	X	X
5	8401-006	Heat Contactor		X	2	2		X	2	2			
5	8401-002	Heat Contactor										X	X
6	8611-006	Ground Terminal	X	X	2	2	X	X	X	X	X	X	X
7	8401-003	Compressor Contactor	X	X	X	X							
7	8401-002	Compressor Contactor					X	X	X	X	X	X	X
8	8552-030	Compressor Capacitor 40/440											
9	8552-005	Condenser Fan Capacitor 10/370					X	X	X	X			
9	8552-026	Condenser Fan Capacitor 15/370									X	X	X
	4010-111	Wiring Diagram	X										
	4010-131	Wiring Diagram		X									
	4010-141	Wiring Diagram			X								
	4010-151	Wiring Diagram				X							
	4010-211	Wiring Diagram					X						
	4010-221	Wiring Diagram						X					
	4010-231	Wiring Diagram							X				
	4010-241	Wiring Diagram								X			
	4010-311	Wiring Diagram									X		
	4010-321	Wiring Diagram										X	
	4010-331	Wiring Diagram											X
	132-092	Control Panel Cover									X	X	X
	132-094	Control Panel Cover	X	X	X	X	X	X	X	X			

Date: 7-11-89
Supersedes:

BLOWER ASSEMBLY

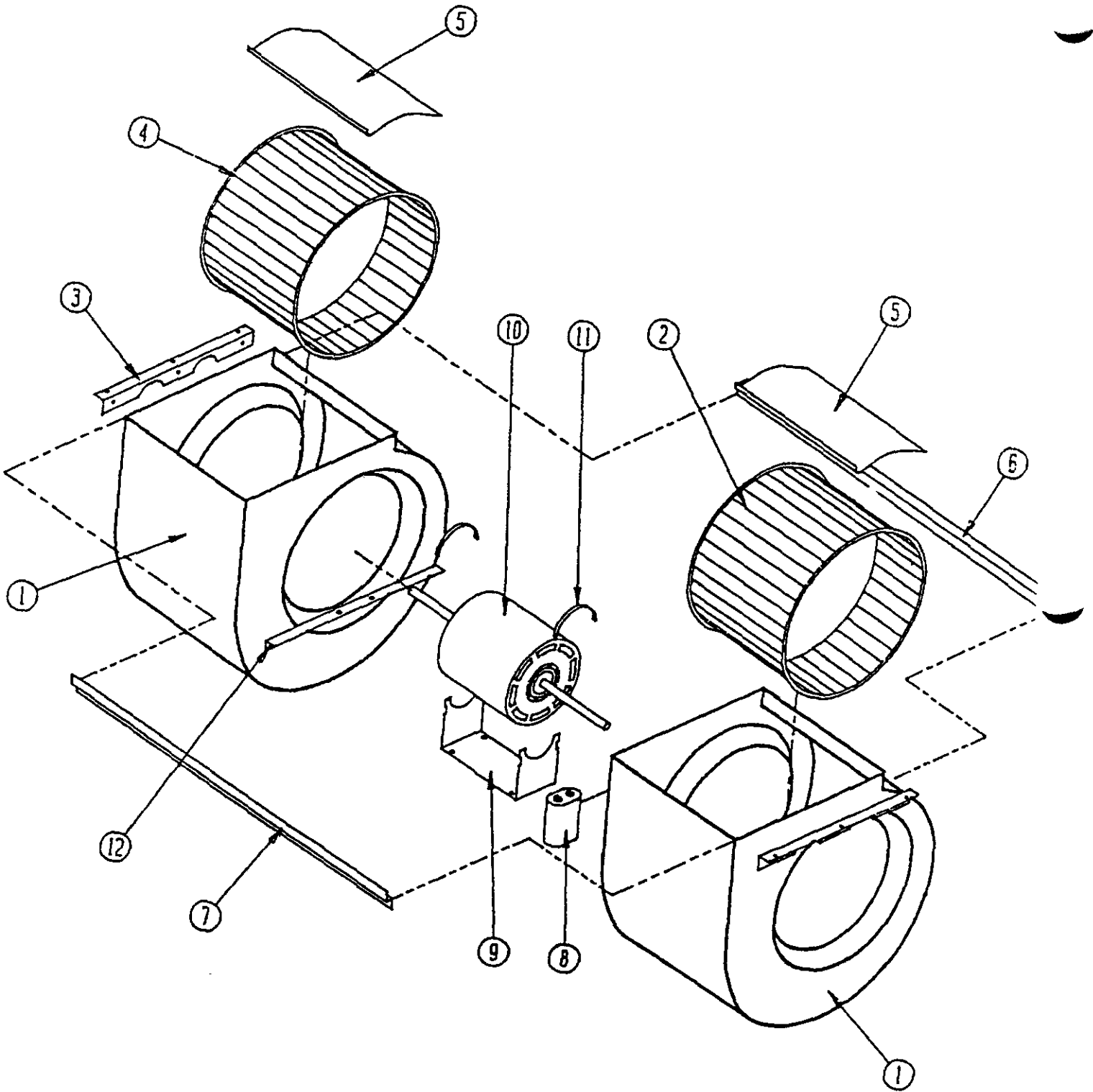

Date: 7-11-89
Supersedes:

BLOWER ASSEMBLY

Dwg. No.	Part No.	Description	9 0 0 1 1 9	9 0 0 1 2 0	9 0 0 1 2 1
1	151-068	Blower Housing	2	2	2
2	5152-011	Blower Wheel 10-8, CW	X	X	
2	5152-057	Blower Wheel 9-8, CW			X
3	104-791	Blower Angle	2	2	2
4	5152-012	Blower Wheel 10-8, CCW	X	X	
4	5152-058	Blower Wheel 9-8, CCW			X
5	144-126	Diffuser	2	2	2
6	104-802	Back Brace	X	X	X
7	102-389	Front Offset	X	X	X
8	8552-005	Capacitor 10/370	X	X	X
9	128-002	Motor Mount--Cradle	X	X	X
10	8106-023	Motor	X		X
10	8106-024	Motor		X	
11	8200-018	Motor Mount Latch	2	2	2
12	104-788	Motor Support Angle	2	2	2

Date: 7-11-89
Supersedes:

