

# REPLACEMENT PARTS MANUAL

## WALL MOUNTED PACKAGE AIR CONDITIONER MODEL 49WA

Manual 2110-406

Revision E

Date 12-10-91

Supersedes 7-26-91

\*\*\*\*\*  
\* GENERAL NOTES \*  
\*\*\*\*\*

\*Revised and/or additional pages may be issued from time to time.  
\*A complete and current manual consists of pages dated as shown in the following index.

\*\*\*\*\*  
\*\* INDEX \*\*  
\*\*\*\*\*

<u>Page Description</u>	<u>Page</u>	<u>Date</u>	<u>Supersedes</u>
Cabinet Components--Exploded View	1	3-01-91	7-11-89
" " --Usage List	2	3-01-91	9-14-90
Functional Components--Exploded View	3	7-11-89	
" " --Usage List	4	7-11-89	
Functional Components--Exploded View	5	7-11-89	
" " --Usage List	6	12-10-91	7-26-91
Functional Components--Exploded View	7	7-11-89	
" " --Usage List	8	12-10-91	7-11-89
Control Panel W/O Circuit Breaker--Layout	9	9-14-90	7-11-89
" " " " " --Usage List	10	7-26-91	3-01-91
Control Panel W/O Circuit Breaker--Layout	11	7-11-89	
" " " " " --Usage List	12	12-10-91	7-11-89
Control Panel W/Circuit Breaker--Layout	13	9-14-90	7-11-89
" " " " " --Usage List	14	3-01-91	9-14-90
Blower Assembly--Exploded View	15	7-11-89	
" " --Usage List	16	9-14-90	7-11-89

\*\*\*\*\*  
\*\*\* IMPORTANT \*\*\*  
\*\*\*\*\*

Contact the installing and/or local Bard distributor for all parts requirements. Make sure you have the complete model and serial number available from the unit rating plate.

CABINET COMPONENTS

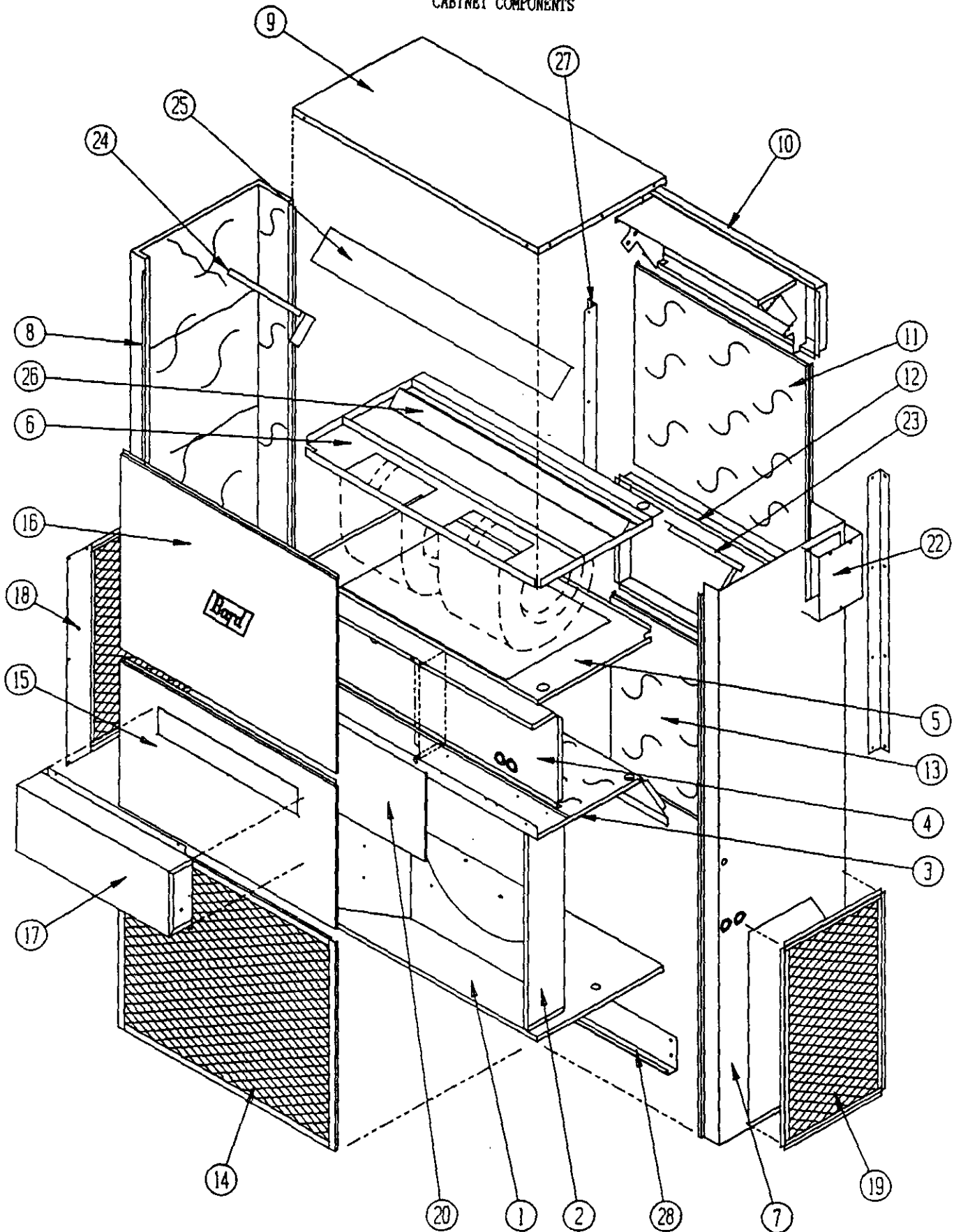

Date: 3-01-97  
Supersedes: 7-11-89

CABINET COMPONENTS

Item	Part No.	Description	U S A G E
1	127-005	Lower Base	X
2	124-003	Fan Shroud	X
3	520-133	Condenser Partition	X
4	Control Pnl. Assy.	See Control Panel Assembly Drawing and Parts List	X
5	130-075	Filter Tray	X
6	521-006	Water Pan/Blower Partition	X
7	501-168	Right Side	X
8	501-169	Left Side	X
9	506-097	Top	X
10	111-019	Outlet Airframe Assembly	X
11	508-059	Upper Back	X
12	111-020	Inlet Air Frame Assembly	X
13	108-060	Lower Back	X
14	119-005	Coil Grille	X
15	552-108	Service Door	X
16	514-047	Upper Front	X
17	962002	Fresh Air Damper	X
18	119-007	Left Side Grille	X
19	119-008	Right Side Grille	X
20	Control Cover	See Control Panel Assembly Drawing and Parts List	X
22	542X005	Right Side Cover Plate	X
23	140-010	Support--Right Coil	X
24	140-011	Support--Left Coil	X
25	134-011	Top Evaporator Fill	X
26	136-003	Bottom Evaporator Fill	X
27	112-009	Side Mounting Bracket	X
28	112-006	Bottom Mounting Bracker	X

Date: 3-01-91  
Supersedes: 9-14-90

FUNCTIONAL COMPONENTS

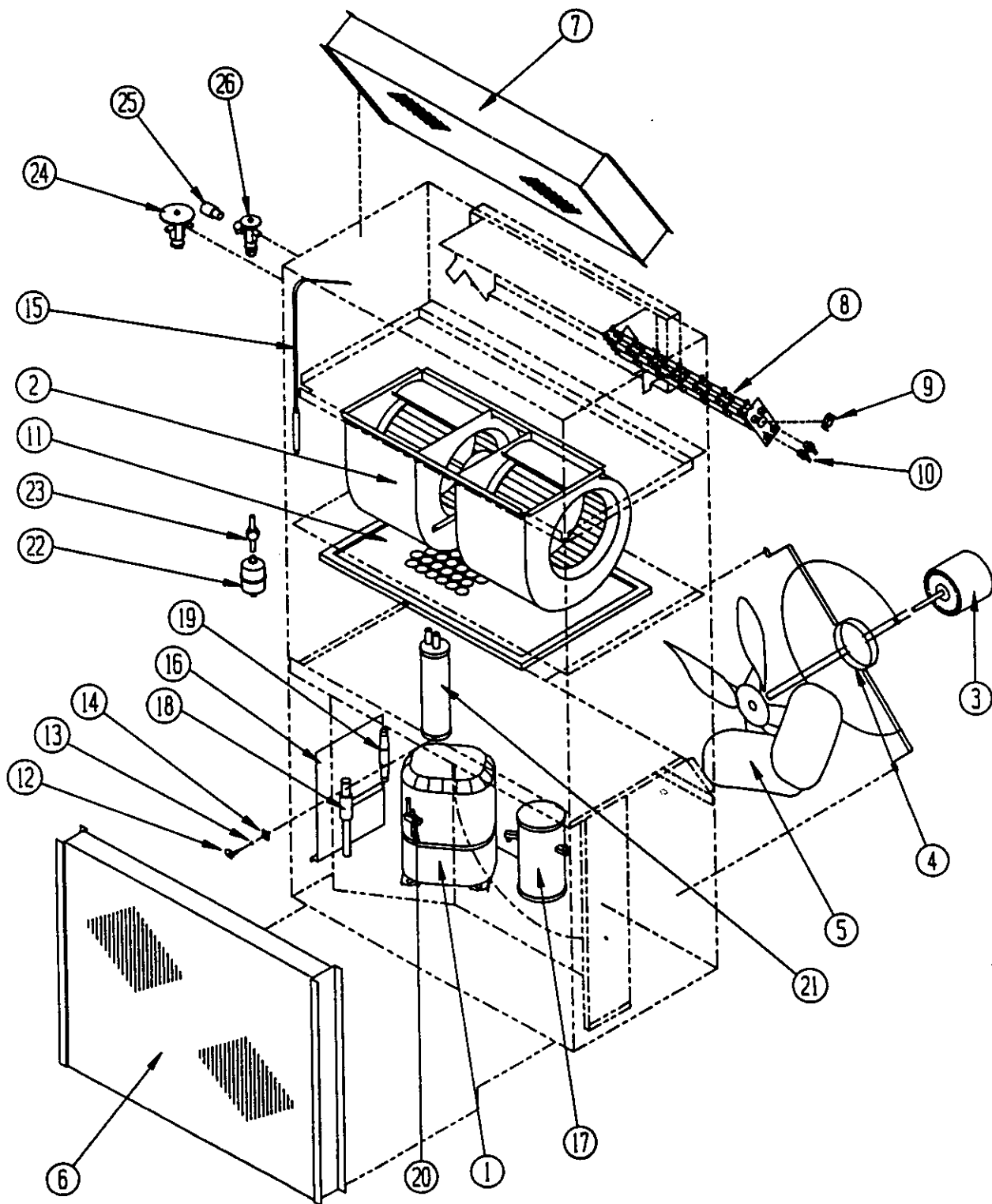

Date: 7-11-89  
Supersedes:

FUNCTIONAL COMPONENTS

Dwg. No.	Part No.	Description	4 9 W A   A O O N, C	4 9 W A   A O O N, C	4 9 W A   A O O N, C	4 9 W A   A O O N, C	4 9 W A   B O O N, C	4 9 W A   B O O N, C	4 9 W A   B O O N, C	4 9 W A   B O O N, C	4 9 W A   C O O N, C	4 9 W A   C O O N, C	4 9 W A   C O O N, C
1	8000-063	Compressor CRK3-0325-PFV	x	x	x	x							
1	8000-064	Compressor CRK3-0325-TF5					x	x	x	x			
1	8000-065	Compressor CRK3-0325-TFD									x	x	x
2	900-119	Blower Assembly (Complete)	x	x	x	x	x	x	x	x			
2	900-120	Blower Assembly (Complete)									x	x	x
3	8105-035	Condenser Motor	x	x	x	x	x	x	x	x			
3	8105-030	Condenser Motor									x	x	x
4	8200-004	Motor Mount--Condenser	x	x	x	x	x	x	x	x	x	x	x
5	5151-027	Fan Blade	x	x	x	x	x	x	x	x	x	x	x
6	5051-028	Condenser Coil	x	x	x	x	x	x	x	x	x	x	x
7	5060-025	Evaporator Coil	x	x	x	x	x	x	x	x	x	x	x
8	8604-091	Heat Strip		x		2							
8	8604-047	Heat Strip			x				x				
8	8604-048	Heat Strip						x		x			
8	8604-072	Heat Strip										x	
8	8604-052	Heat Strip											x
9	8402-047	Limit Control		x	x	x		x	x	x		x	x
10	8402-032	Thermal Cutoff 4K9239H		2	3	4		2	3	4			
10	8402-057	Thermal Cutoff 4K4218AH										2	3
11	7004-016	Air Filter 20 x 30 x 1	x	x	x	x	x	x	x	x	x	x	x
12	1171-019	1/4 Turn Fastener	x	x	x	x	x	x	x	x	x	x	x
13	1171-021	Retainer Washer	x	x	x	x	x	x	x	x	x	x	x
14	1171-020	Receptacle	x	x	x	x	x	x	x	x	x	x	x
15	800-0093	Cooling Capillary Assembly	x	x	x	x	x	x	x	x	x	x	x

Date: 7-11-89  
Supersedes:

FUNCTIONAL COMPONENTS

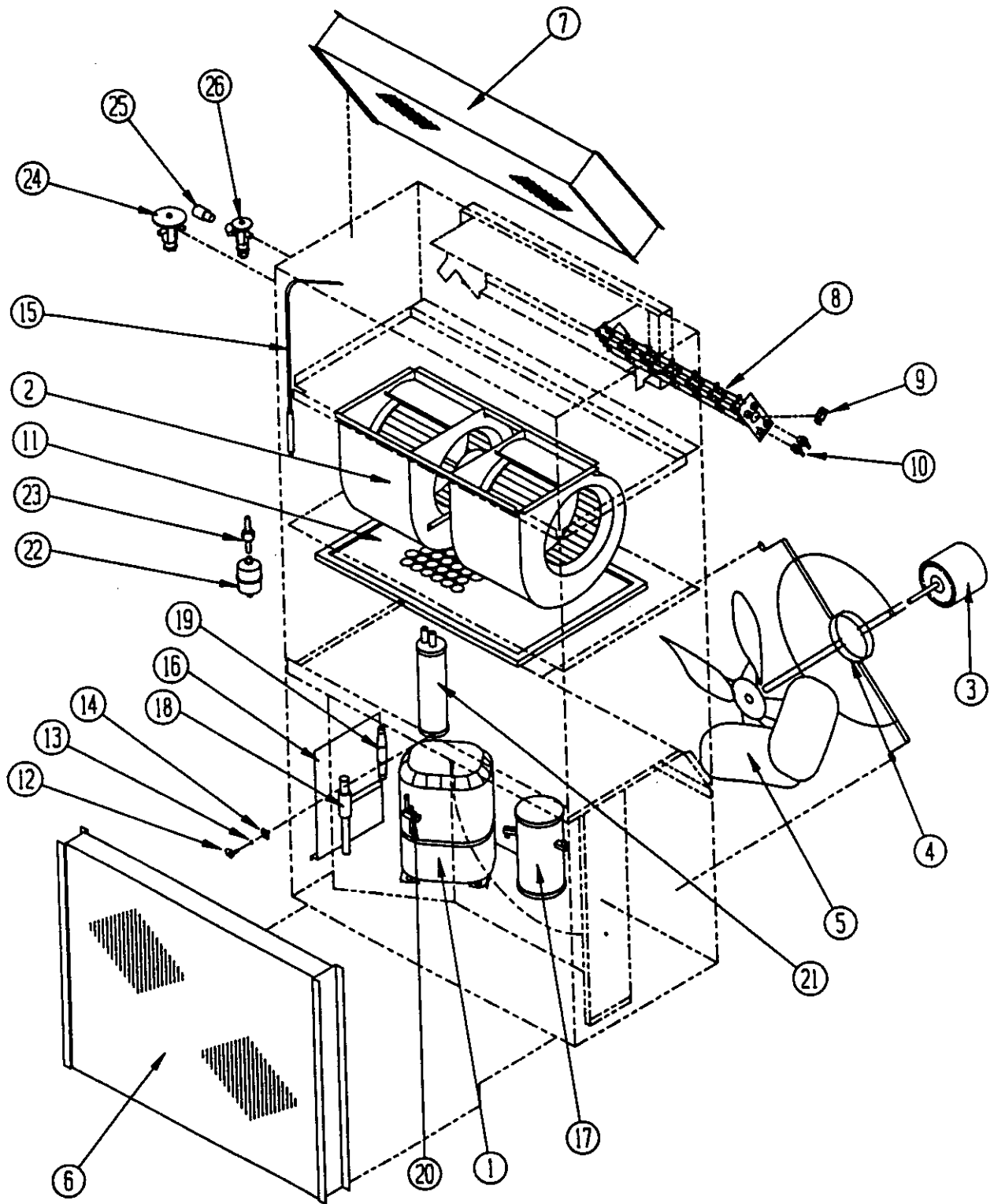

Date: 7-11-89  
Supersedes:

FUNCTIONAL COMPONENTS

Dwg. No.	Part No.	Description	49WA-10H	49WA-10H	49WA-10H	49WA-10H	49WA-10H
1	8000-063	Compressor CRK3-0325-PFV	X				
1	8000-064	Compressor CRK3-0325-TF5		X	X		
1	8000-065	Compressor CRK3-0325-TFD				X	
2	900-119	Blower Assembly (Complete)	X	X	X		X
2	900-120	Blower Assembly (Complete)				X	
3	8105-035	Condenser Motor	X	X	X		
3	8105-030	Condenser Motor				X	
4	8200-004	Motor Mount--Condenser	X	X	X	X	X
5	5151-027	Fan Blade	X	X	X	X	
6	5051-028	Condenser Coil	X	X	X	X	X
7	5060-025	Evaporator Coil	X	X	X	X	X
8	8604-091	Heat Strip	X				
8	8604-048	Heat Strip		X	X		
8	8604-072	Heat Strip					
8	8604-052	Heat Strip				X	
9	8402-047	Limit Control	X	X	X	X	X
10	8402-032	Thermal Cutoff 4K9239H	2	2	4		4
10	8402-057	Thermal Cutoff 4K4218AH				3	
11	7004-016	Air Filter 20 x 30 x 1	X	X	X	X	X
12	1171-019	1/4 Turn Fastener	X	X	X	X	X
13	1171-021	Retainer Washer	X	X	X	X	X
14	1171-020	Receptacle	X	X	X	X	X
16	---	Wire Shield					
17	5203-006	Receiver	X	X	X	X	X
18	5651-015	Head Pressure Control Valve	X	X	X	X	X
19	5651-016	Pressure Differential Valve	X	X	X	X	X
20	5651-051	Shutoff Valve	X	X	X	X	X
21	5202-018	Accumulator	X	X	X	X	X
22	5201-002	Filter Drier	X	X	X	X	X
23	5201-014	Sight Glass	X	X	X	X	X
24	5651-064	Hot Gas Bypass Valve	X	X	X	X	X
25	5651-008	Distributor	X	X	X	X	X
26	5651-040	Expansion Valve	X	X	X	X	X

Date: 12-10-91  
Supersedes: 7-26-91

FUNCTIONAL COMPONENTS

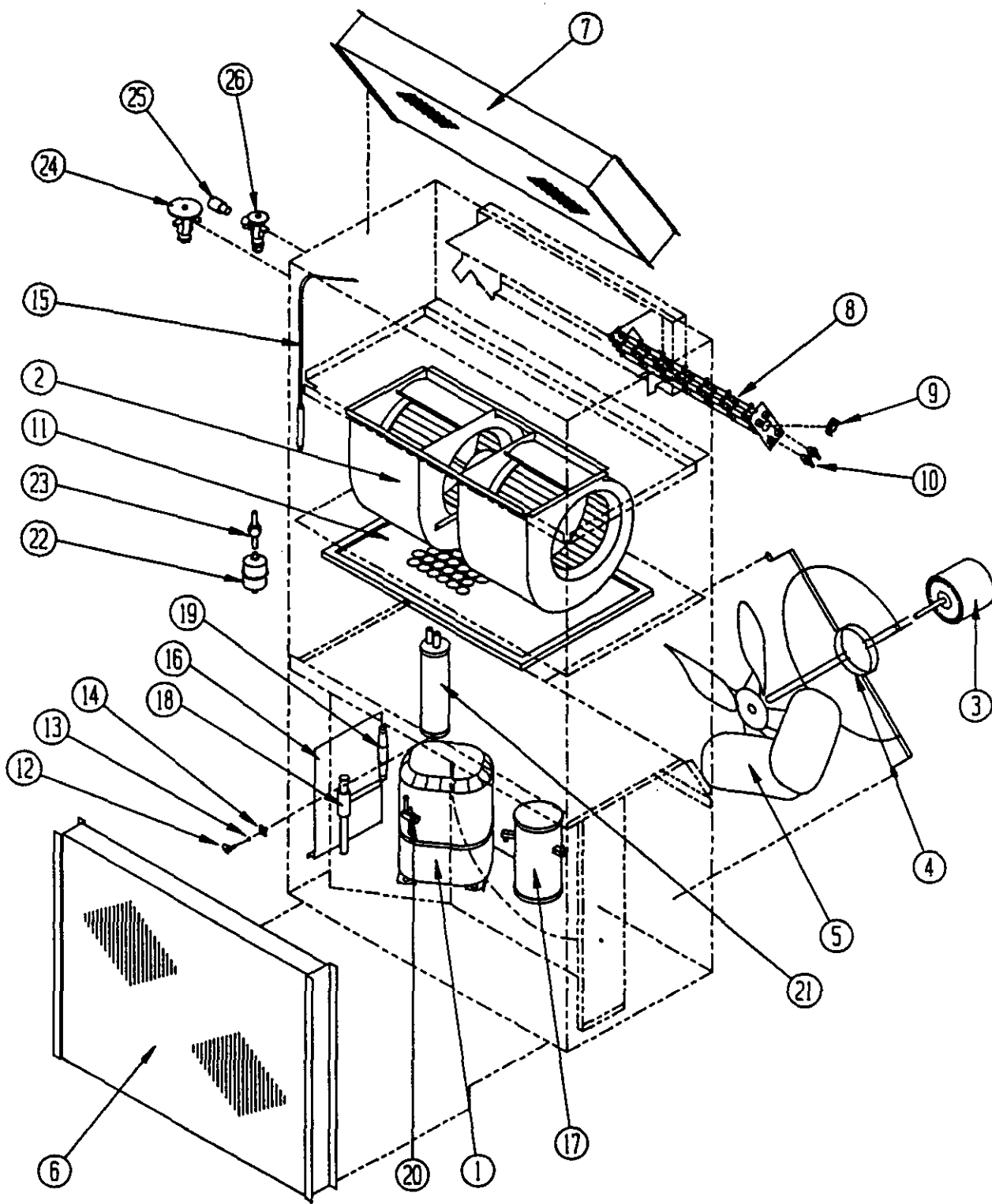

Date: 7-11-89  
Supersedes:



FUNCTIONAL COMPONENTS

Dwg. No.	Part No.	Description	4 9 W A   E 1 5 N	4 9 W A   F 0 N	4 9 W A   F 1 4 H	4 9 W A   F 1 4 N	4 9 W A   G 0 N	4 9 W A   G 1 5 N
1	8000-026	Compressor					X	X
1	8000-064	Compressor	X					
1	8000-065	Compressor		X	X	X		
2	900-119	Blower Assembly (Complete)	X	X	X	X	X	X
3	8105-014	Condenser Motor	X	X	X	X	X	X
4	8200-004	Motor Mount--Condenser	X	X	X	X	X	X
5	5151-026	Fan Blade	X	X	X	X	X	X
6	5051-028	Condenser Coil	X	X	X	X	X	X
7	5060-025	Evaporator Coil	X	X	X	X	X	X
8	8604-087	Heat Strip			X	X		
8	8604-047	Heat Strip	X					X
9	8402-047	Limit Control	X		X	X		X
10	8402-032	Thermal Cutoff 4K9239H	3		4	4		3
11	7004-016	Air Filter 20 x 30 x 1	X	X	X	X	X	X
12	1171-019	1/4 Turn Fastener	X	X	X	X	X	X
13	1171-021	Retainer Washer	X	X	X	X	X	X
14	1171-020	Receptacle	X	X	X	X	X	X
15	800-0093	Cooling Capillary Assembly	X	X		X	X	X

Date: 12-10-91  
Supersedes: 7-11-89

CONTROL PANEL WITHOUT CIRCUIT BREAKER

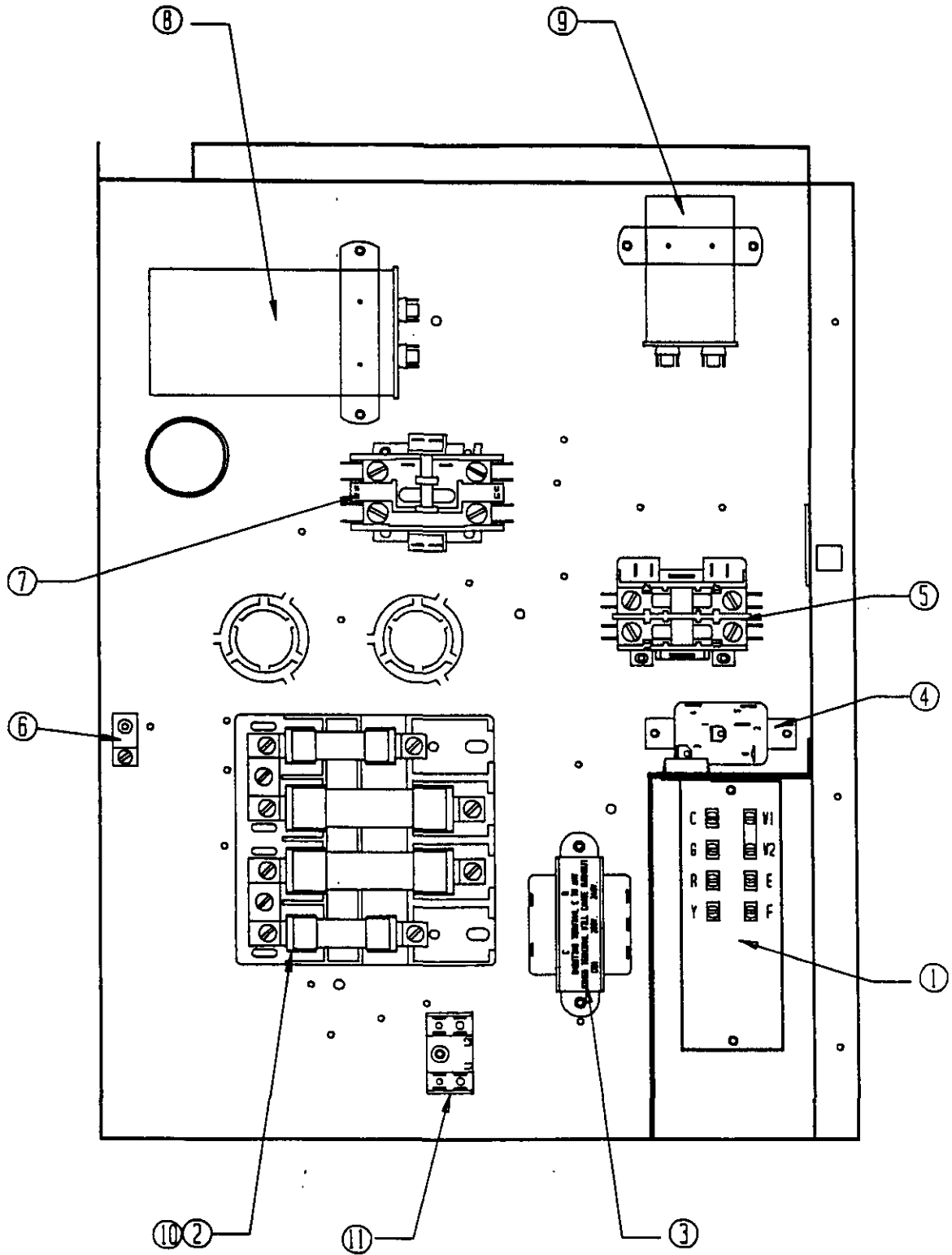

Date: 9-14-90  
 Supersedes: 7-11-90

CONTROL PANEL  
WITHOUT CIRCUIT BREAKER

Dwg. No.	Part No.	Description	49WA-00N	49WA-01H	49WA-01N, H	49WA-015N,	49WA-020N	49WA-00N	49WA-009N, H	49WA-015N	49WA-018H	49WA-018H	49WA-00N	49WA-009N	49WA-015N, H
1	8607-018	Low Voltage Strip	x	x	x	x	x	x	x	x	x	x	x	x	x
2	8607-013	Terminal Block	x	A	x			x	x	x	A	x	x	x	x
2	8607-014	Terminal Block													
2	8614-017	Fuse Block				x									
2	8614-018	Fuse Block		B			x								
2	8614-020	Fuse Block									B				
3	8407-034	Transformer	x	x	x	x	x	x	x	x	x	x			
3	8407-027	Transformer											x	x	x
4	8201-009	Blower Relay	x	x	x	x	x	x	x	x	x	x			
4	8201-032	Blower Relay											x	x	x
5	8401-006	Heat Contactor		x	x	2	2		x	2	x	2			
5	8401-002	Heat Contactor													
6	8611-006	Ground Terminal	x	x	x	x	x	x	x	x	x	x	x	x	x
7	8401-003	Compressor Contactor	x	x	x	x	x								
7	8401-002	Compressor Contactor						x	x	x	x	x	x	x	x
8	8552-030	Compressor Capacitor 40/440	x	x	x	x	x								
9	8552-005	Condenser Fan Capacitor 10/370	x	x	x	x	x	x	x	x	x	x			
9	8552-026	Condenser Fan Capacitor 15/370											x	x	x
10	8607-015	Phenolic Insulator											x	x	x
11	8607-017	Terminal Block											x	x	x
	4010-110	Wiring Diagram	x												
	4010-130	Wiring Diagram		A	x										
	4010-133	Wiring Diagram		B											
	4010-140	Wiring Diagram				x									
	4010-150	Wiring Diagram					x								
	4010-210	Wiring Diagram						x							
	4010-220	Wiring Diagram							x						
	4010-230	Wiring Diagram								x					
	4010-240	Wiring Diagram									A	x			
	4010-242	Wiring Diagram									B				
	4010-310	Wiring Diagram											x		
	4010-320	Wiring Diagram												x	
	4010-330	Wiring Diagram													x
	132-081	Control Panel Cover	x	x	x			x	x	x	x	x	x	x	x
	133-054	Control Panel Cover				x	x								

(A) Used in units produced before H91.

(B) Used in units produced with H91 date code and later.

Date: 7-26-91  
Supersedes: 3-01-91

CONTROL PANEL WITHOUT CIRCUIT BREAKER

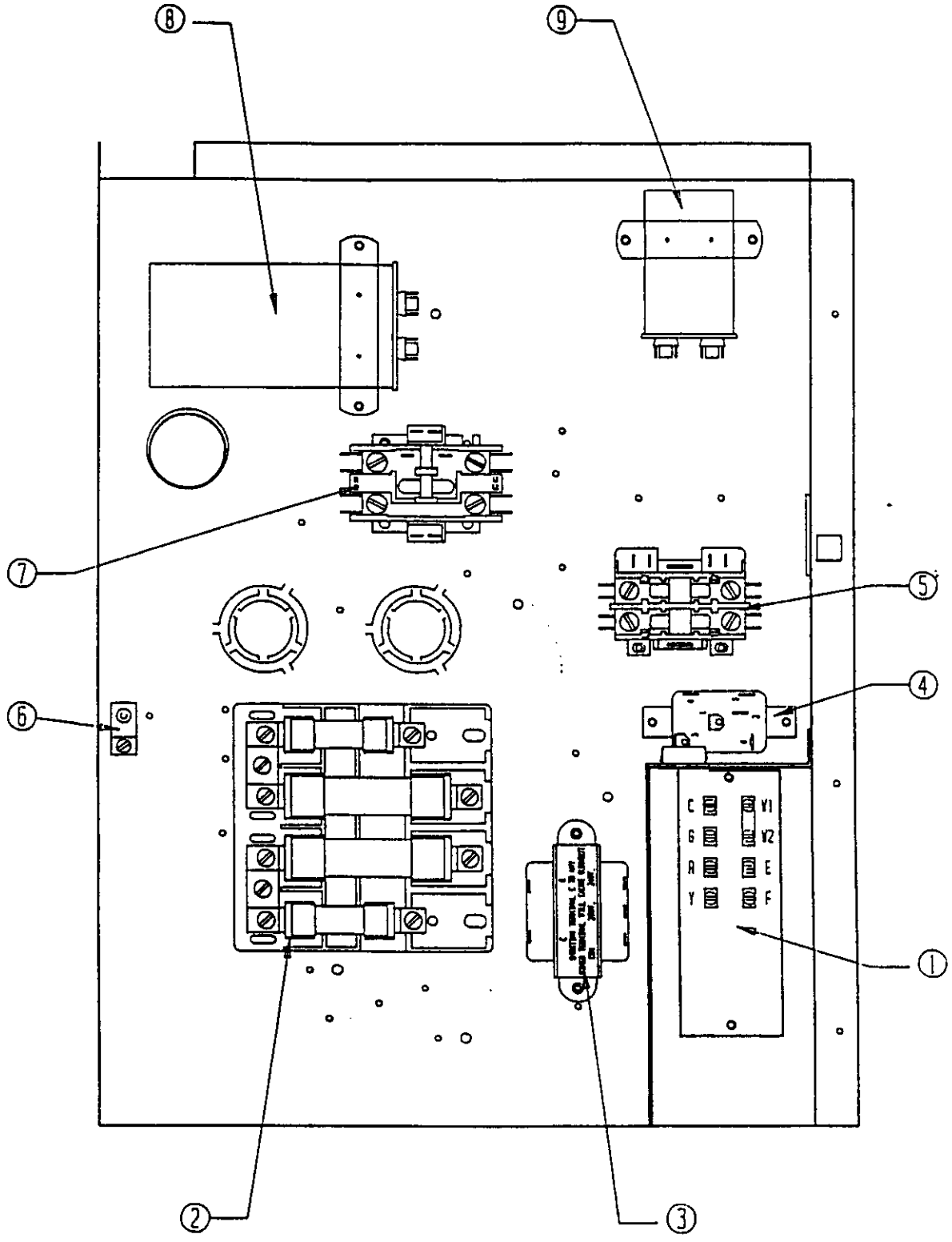

Date: 7-11  
Supersedes:

CONTROL PANEL  
WITHOUT CIRCUIT BREAKER

Dwg. No.	Part No.	Description	49 W A   E O O N	49 W A   E O 5 N	49 W A   F O O N	49 W A   F I 4 N, H	49 W A   G O O N	49 W A   G I 5 N
1	8607-018	Low Voltage Strip	X	X	X	X	X	X
2	8607-013	Terminal Block			2	2	X	
2	8607-014	Terminal Block	X	X				
2	8614-017	Fuse Block						X
3	8407-034	Transformer	X	X	X	X	X	X
4	8201-009	Blower Relay	X	X	X	X	X	X
5	8401-006	Heat Contactor		2				2
5	8401-002	Heat Contactor				2		
6	8611-006	Ground Terminal	X	X	X	X	X	X
7	8401-016	Compressor Contactor					X	X
7	8401-002	Compressor Contactor	X	X	X	X		
8	8552-030	Compressor Capacitor 40/440					X	X
9	8552-005	Condenser Fan Capacitor 10/370	X	X	X	X	X	X
10	---							
	4010-410	Wiring Diagram					X	
	4010-440	Wiring Diagram						X
	4010-510	Wiring Diagram	X					
	4010-530	Wiring Diagram		X				
	4010-610	Wiring Diagram			X			
	4010-630	Wiring Diagram				X		
	132-081	Control Panel Cover	X	X	X	X	X	
	133-054	Control Panel Cover						X

Date: 12-10-71  
Supersedes: 7-11-89

CONTROL PANEL WITH CIRCUIT BREAKER

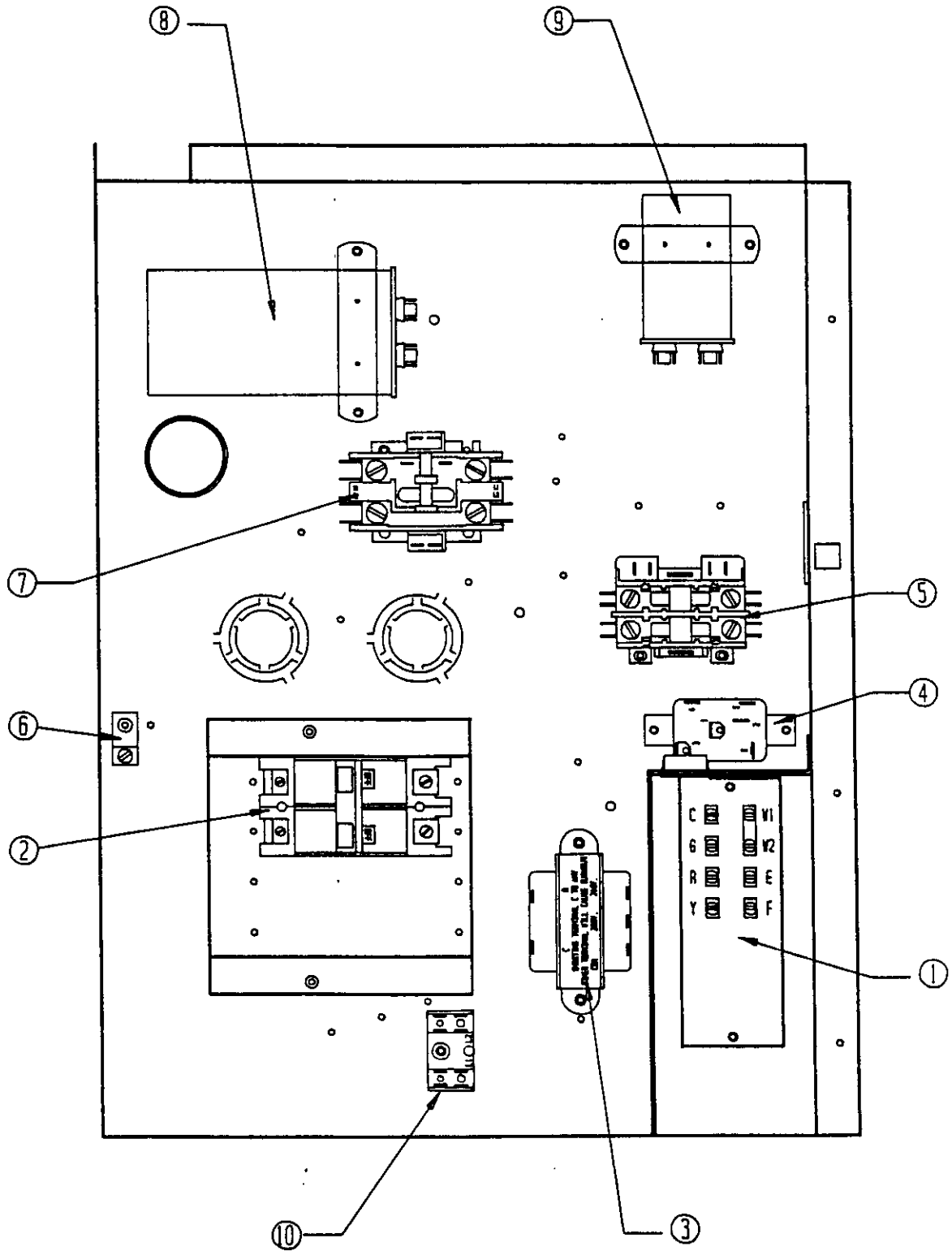

Date: 9-14-50  
 Supersedes: 7-11-90

CONTROL PANEL  
WITH CIRCUIT BREAKER

Dwg. No.	Part No.	Description	49WA	49WA	49WA	49WA	49WA	49WA	49WA	49WA	49WA	49WA	49WA
			A	A	A	A	B	B	B	B	C	C	C
			O	I	I	2	O	O	I	I	O	O	I
			C	C	C	C	C	C	C	C	C	C	C
1	8607-018	Low Voltage Terminal Strip	X	X	X	X	X	X	X	X	X	X	X
2	8615-015	Circuit Breaker 50A	X										
2	8615-016	Circuit Breaker 60A		X	X	2							
2	8615-013	Circuit Breaker 30A			X								
2	8615-019	Circuit Breaker 35A					X	X					
2	8615-011	Circuit Breaker 60A							X	X			
2	8615-030	Circuit Breaker 20A									X	X	
2	8615-032	Circuit Breaker 30A											X
3	8407-034	Transformer	X	X	X	X	X	X	X	X			
3	8407-027	Transformer									X	X	X
4	8201-009	Blower Relay	X	X	X	X	X	X	X	X			
4	8201-032	Blower Relay									X	X	X
5	8401-006	Heat Contactor		X	2	2		X	2	2			
5	8401-002	Heat Contactor										X	X
6	8611-006	Ground Terminal	X	X	2	2	X	X	X	X	X	X	X
7	8401-003	Compressor Contactor	X	X	X	X							
7	8401-002	Compressor Contactor					X	X	X	X	X	X	X
8	8552-030	Compressor Capacitor 40/440	X	X	X	X							
9	8552-005	Condenser Fan Capacitor 10/370	X	X	X	X	X	X	X	X			
9	8552-026	Condenser Fan Capacitor 15/370									X	X	X
10	8607-017	Terminal Block									X	X	X
	4010-111	Wiring Diagram	X										
	4010-131	Wiring Diagram		X									
	4010-141	Wiring Diagram			X								
	4010-151	Wiring Diagram				X							
	4010-211	Wiring Diagram					X						
	4010-221	Wiring Diagram						X					
	4010-231	Wiring Diagram							X				
	4010-241	Wiring Diagram								X			
	4010-311	Wiring Diagram									X		
	4010-321	Wiring Diagram										X	
	4010-331	Wiring Diagram											X
	132-092	Control Panel Cover	X	X	X	X	X	X	X	X	X	X	X
	132-094	Control Panel Cover	X	X	X	X	X	X	X	X	X	X	X

Date: 3-01-91  
Supersedes: 9-14-90

BLOWER ASSEMBLY

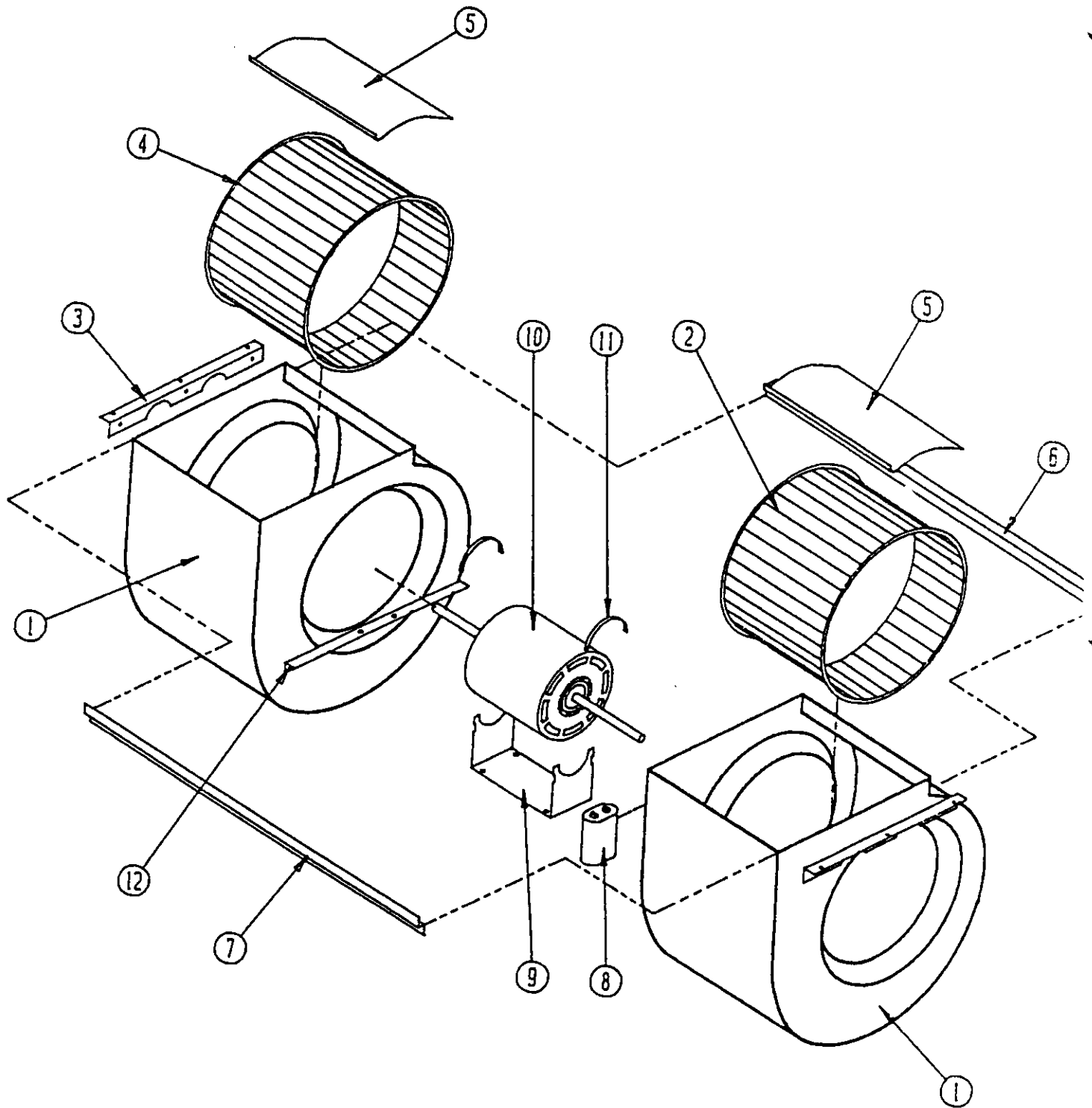

Date: 7-11-89  
Supersedes:



BLOWER ASSEMBLY

Dwg. No.	Part No.	Description	9 0 0   1 1 9	9 0 0   1 2 0	9 0 0   1 2 1
1	151-068	Blower Housing	2	2	2
2	5152-011	Blower Wheel 10-8, CW.	x	x	
2	5152-057	Blower Wheel 9-8, CW			x
3	104-791	Blower Angle	2	2	2
4	5152-012	Blower Wheel 10-8, CCW	x	x	
4	5152-058	Blower Wheel 9-8, CCW			x
5	144-126	Diffuser	2	2	2
6	104-802	Back Brace	x	x	x
7	<del>102-389</del>	Front Offset	x	x	x
8	8552-005	Capacitor 10/370	x	x	x
9	128-002	Motor Mount--Cradle	x	x	x
10	8106-023	Motor	x		x
10	8106-025	Motor		x	
11	8200-018	Motor Mount Latch	2	2	2
12	104-788	Motor Support Angle	2	2	2

103

Date: 9-14-90  
Supersedes: 7-11-89

