

REPLACEMENT PARTS MANUAL

WALL MOUNTED PACKAGE AIR CONDITIONER MODEL 49WA

Manual 2110-406

Revision A

Date 1-25-90

Supersedes 7-11-89

* GENERAL NOTES *

*Revised and/or additional pages may be issued from time to time.
*A complete and current manual consists of pages dated as shown in the following index.

** INDEX **

<u>Page Description</u>	<u>Page</u>	<u>Date</u>	<u>Supersedes</u>
Cabinet Components--Exploded View	1	7-11-89	
" " --Usage List	2	1-25-90	7-11-89
Functional Components--Exploded View	3	7-11-89	
" " --Usage List	4	7-11-89	
Functional Components--Exploded View	5	7-11-89	
" " --Usage List	6	7-11-89	
Functional Components--Exploded View	7	7-11-89	
" " --Usage List	8	7-11-89	
Control Panel W/O Circuit Breaker--Layout	9	7-11-89	
" " " " " --Usage List	10	7-11-89	
Control Panel W/O Circuit Breaker--Layout	11	7-11-89	
" " " " " --Usage List	12	7-11-89	
Control Panel W/Circuit Breaker--Layout	13	7-11-89	
" " " " " --Usage List	14	7-11-89	
Blower Assembly--Exploded View	15	7-11-89	
" " --Usage List	16	7-11-89	

*** IMPORTANT ***

Contact the installing and/or local Bard distributor for all parts requirements. Make sure you have the complete model and serial number available from the unit rating plate.

BARD MANUFACTURING COMPANY

BRYAN, OHIO 43506

CABINET COMPONENTS

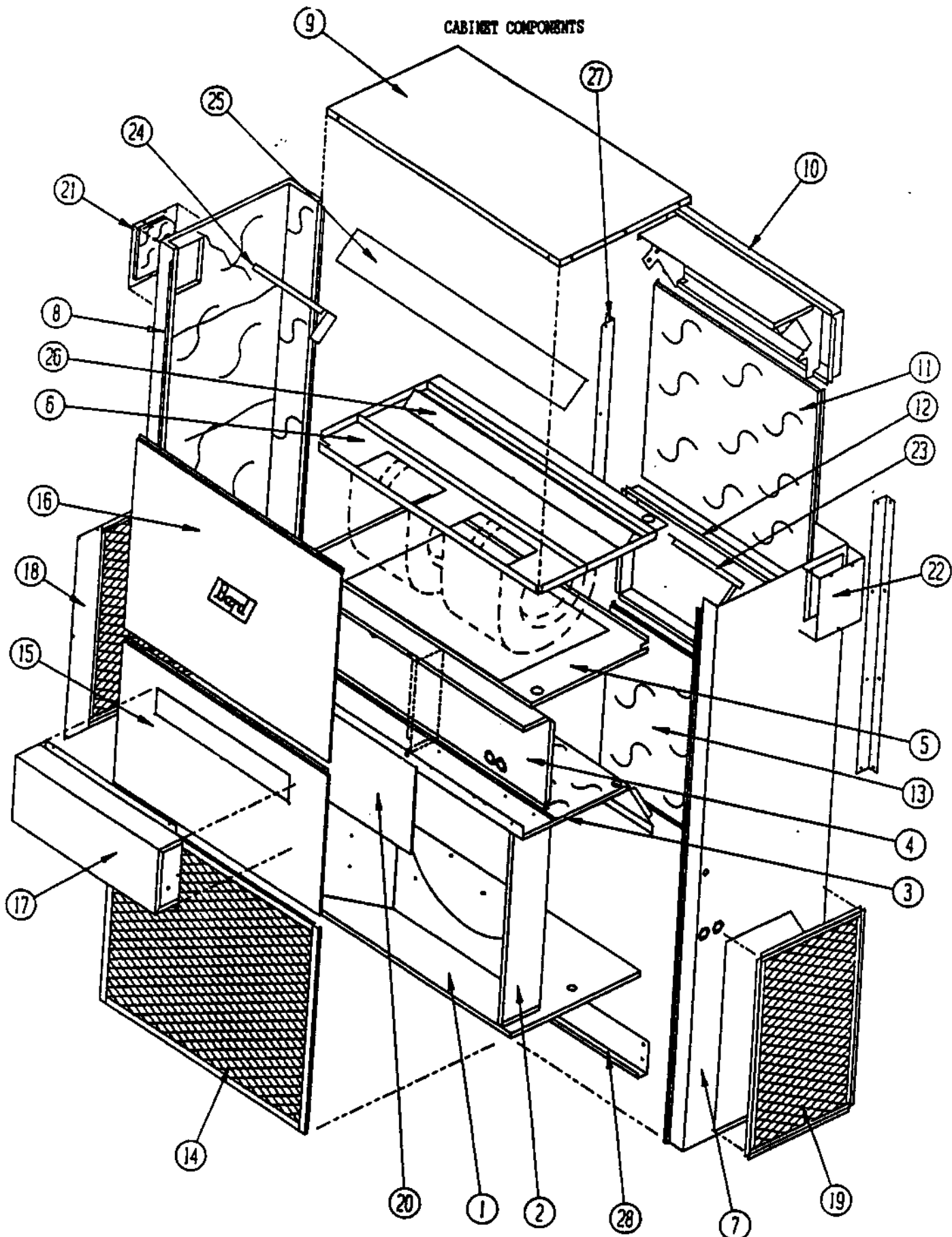

Date: 7-11-89
Supersedes:

CABINET COMPONENTS

Item	Part No.	Description	U S A G E
1	127-005	Lower Base	X
2	124-003	Fan Shroud	X
3	520-133	Condenser Partition	X
4	Control Pnl. Assy.	See Control Panel Assembly Drawing and Parts List	X
5	131-004	Filter Tray	X
6	521-006	Water Pan/Blower Partition	X
7	501-168	Right Side	X
8	501-169	Left Side	X
9	506-097	Top	X
10	111-019	Outlet Airframe Assembly	X
11	508-059	Upper Back	X
12	111-020	Inlet Air Frame Assembly	X
13	508-060	Lower Back	X
14	119-005	Coil Grille	X
15	552-108	Service Door	X
16	514-047	Upper Front	X
17	962002	Fresh Air Damper → FAD25B	X
18	119-006	Left Side Grille	X
19	119-008	Right Side Grille	X
20	Control Cover	See Control Panel Assembly Drawing and Parts List	X
21	542T005	Left Side Cover Plate	X
22	542R005	Right Side Cover Plate	X
23	140-010	Support--Right Coil	X
24	140-011	Support--Left Coil	X
25	134-011	Top Evaporator Fill	X
26	137-003	Bottom Evaporator Fill	X
27	112-009	Side Mounting Bracket	X
28	112-006	Bottom Mounting Bracker	X

Date: 1-25-90
Supersedes: 7-11-89

FUNCTIONAL COMPONENTS

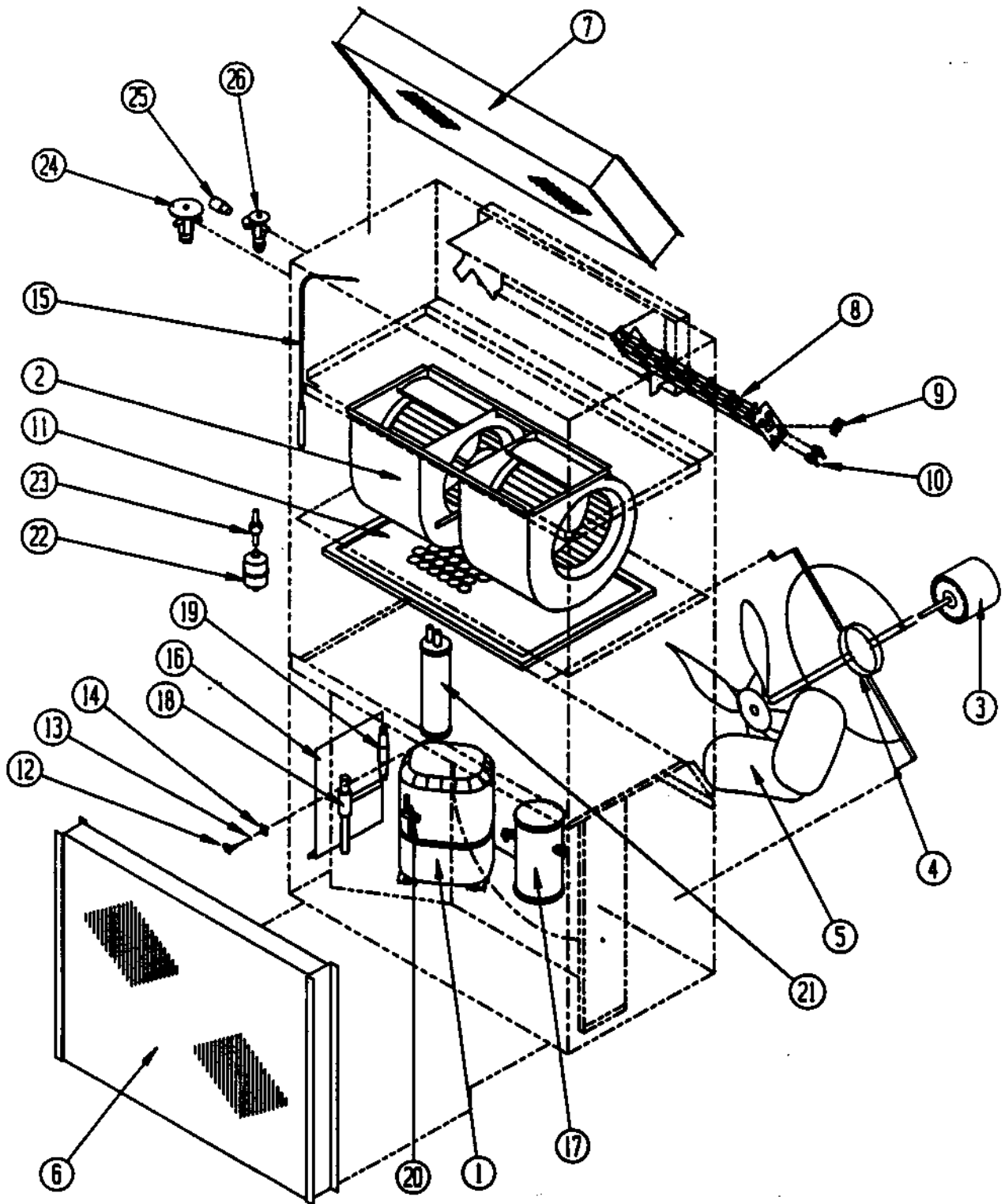

Date: 7-11-89
Supersedes:

FUNCTIONAL COMPONENTS

Dwg. No.	Part No.	Description	49 W A A O O N, C	49 W A A O O N, C	49 W A A 1 5 N, C	49 W A A 2 O N, C	49 W A B O O N, C	49 W A B O 9 N, C	49 W A B 1 5 N, C	49 W A B 1 8 N, C	49 W A C O O N, C	49 W A C O 9 N, C	49 W A C 1 5 N, C
1	8000-063	Compressor CRK3-0325-PFV	X	X	X	X							
1	8000-064	Compressor CRK3-0325-TF5					X	X	X	X			
1	8000-065	Compressor CRK3-0325-YFD									X	X	X
2	900-119	Blower Assembly (Complete)	X	X	X	X	X	X	X	X			
2	900-120	Blower Assembly (Complete)									X	X	X
3	8105-035	Condenser Motor	X	X	X	X	X	X	X	X			
3	8105-030	Condenser Motor									X	X	X
4	8200-004	Motor Mount--Condenser	X	X	X	X	X	X	X	X	X	X	X
5	5151-027	Fan Blade	X	X	X	X	X	X	X	X	X	X	X
6	5051-028	Condenser Coil	X	X	X	X	X	X	X	X	X	X	X
7	5060-025	Evaporator Coil	X	X	X	X	X	X	X	X	X	X	X
8	8604-091	Heat Strip		X		2							
8	8604-047	Heat Strip			X				X				
8	8604-048	Heat Strip					X			X			
8	8604-072	Heat Strip										X	
8	8604-052	Heat Strip											X
9	8402-047	Limit Control		X	X	X		X	X	X		X	X
10	8402-032	Thermal Cutoff 4K9239H		2	3	4		2	3	4			
10	8402-057	Thermal Cutoff 4K4218AH										2	3
11	7004-016	Air Filter 20 x 30 x 1	X	X	X	X	X	X	X	X	X	X	X
12	1171-019	1/4 Turn Fastener	X	X	X	X	X	X	X	X	X	X	X
13	1171-021	Retainer Washer	X	X	X	X	X	X	X	X	X	X	X
14	1171-020	Receptacle	X	X	X	X	X	X	X	X	X	X	X
15	800-0093	Cooling Capillary Assembly	X	X	X	X	X	X	X	X	X	X	X

Date: 7-11-89
Supersedes:

FUNCTIONAL COMPONENTS

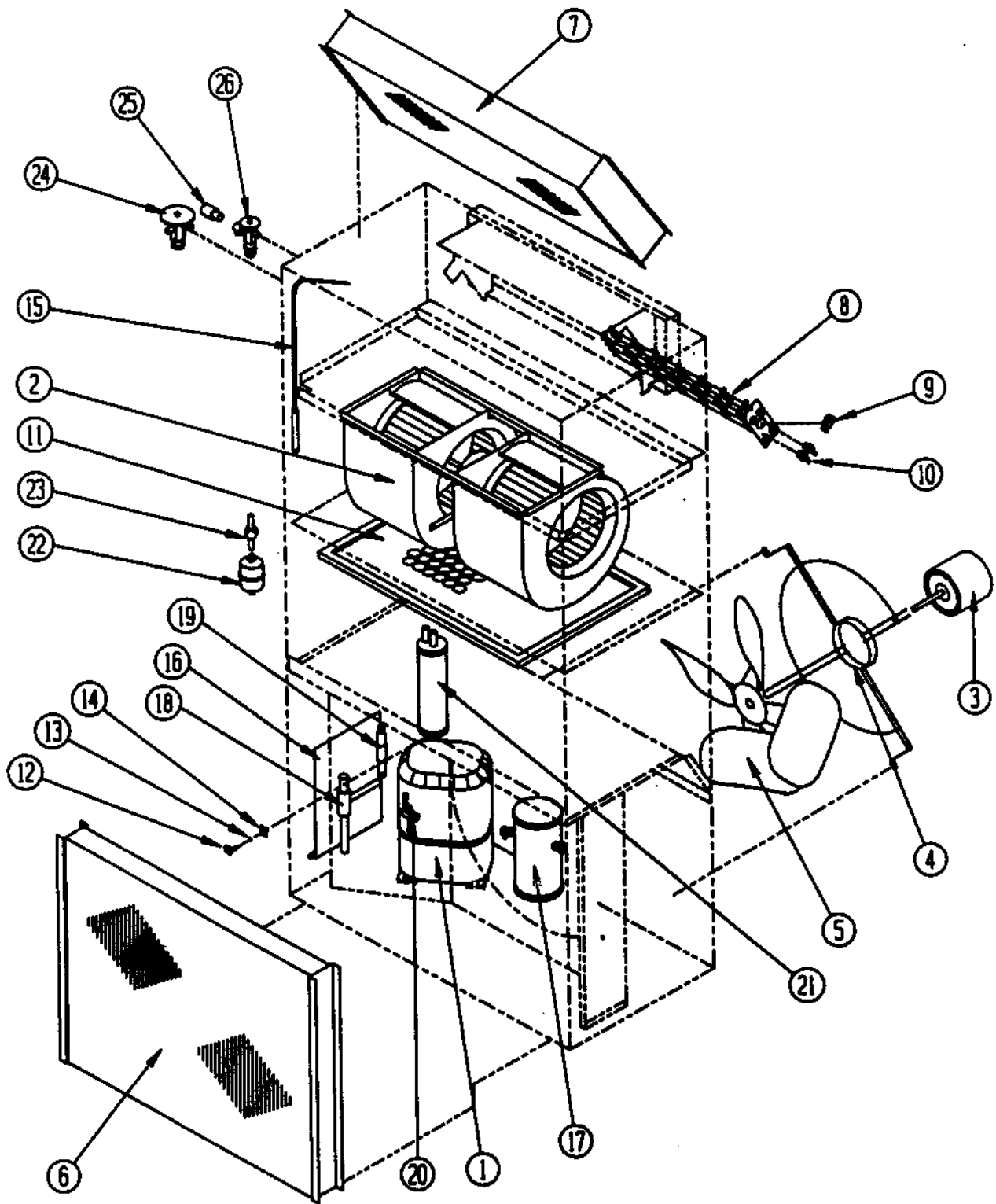

Date: 7-11-89
Supersedes:

FUNCTIONAL COMPONENTS

Dwg. No.	Part No.	Description	4	4	4	4	4	4	4	4	4
			9	9	9	9	9	9	9	9	9
			W	W	W	W	W	W	W	W	W
			A	A	A	A	A	A	A	A	A
			1	1	1	2	2	2	3	3	3
			O	O	O	O	O	O	O	O	O
			H	H	H	H	H	H	H	H	H
1	8000-063	Compressor CRK3-0325-PFV	X	X	X						
1	8000-064	Compressor CRK3-0325-TF5				X	X	X			
1	8000-065	Compressor CRK3-0325-TFD							X	X	X
2	900-119	Blower Assembly (Complete)	X	X	X	X	X	X			
2	900-120	Blower Assembly (Complete)							X	X	X
3	8105-035	Condenser Motor	X	X	X	X	X	X			
3	8105-030	Condenser Motor							X	X	X
4	8200-004	Motor Mount--Condenser	X	X	X	X	X	X	X	X	X
5	5151-027	Fan Blade	X	X	X	X	X	X	X	X	X
6	5051-028	Condenser Coil	X	X	X	X	X	X	X	X	X
7	5060-025	Evaporator Coil	X	X	X	X	X	X	X	X	X
8	8604-091	Heat Strip		X	2			X	X		
8	8604-048	Heat Strip									
8	8604-072	Heat Strip								X	
8	8604-052	Heat Strip									X
9	8402-047	Limit Control		X	X		X	X		X	X
10	8402-032	Thermal Cutoff 4K9239R		2	4		2	4			
10	8402-057	Thermal Cutoff 4K4218AR								2	3
11	7004-016	Air Filter 20 x 30 x 1	X	X	X	X	X	X	X	X	X
12	1171-019	1/4 Turn Fastener	X	X	X	X	X	X	X	X	X
13	1171-021	Retainer Washer	X	X	X	X	X	X	X	X	X
14	1171-020	Receptacle	X	X	X	X	X	X	X	X	X
15	800-0093	Cooling Capillary Assembly	X	X	X	X	X	X	X	X	X
16	---	Wire Shield									
17	5203-006	Receiver	X	X	X	X	X	X	X	X	X
18	5651-015	Head Pressure Control Valve	X	X	X	X	X	X	X	X	X
19	5651-016	Pressure Differential Valve	X	X	X	X	X	X	X	X	X
20	5651-051	Shutoff Valve	X	X	X	X	X	X	X	X	X
21	5202-018	Accumulator	X	X	X	X	X	X	X	X	X
22	5201-002	Filter Drier	X	X	X	X	X	X	X	X	X
23	5201-014	Sight Glass	X	X	X	X	X	X	X	X	X
24	5651-064	Hot Gas Bypass Valve	X	X	X	X	X	X	X	X	X
25	5651-008	Distributor	X	X	X	X	X	X	X	X	X
26	5651-040	Expansion Valve	X	X	X	X	X	X	X	X	X

Date: 7-11-89
Supersedes:

FUNCTIONAL COMPONENTS

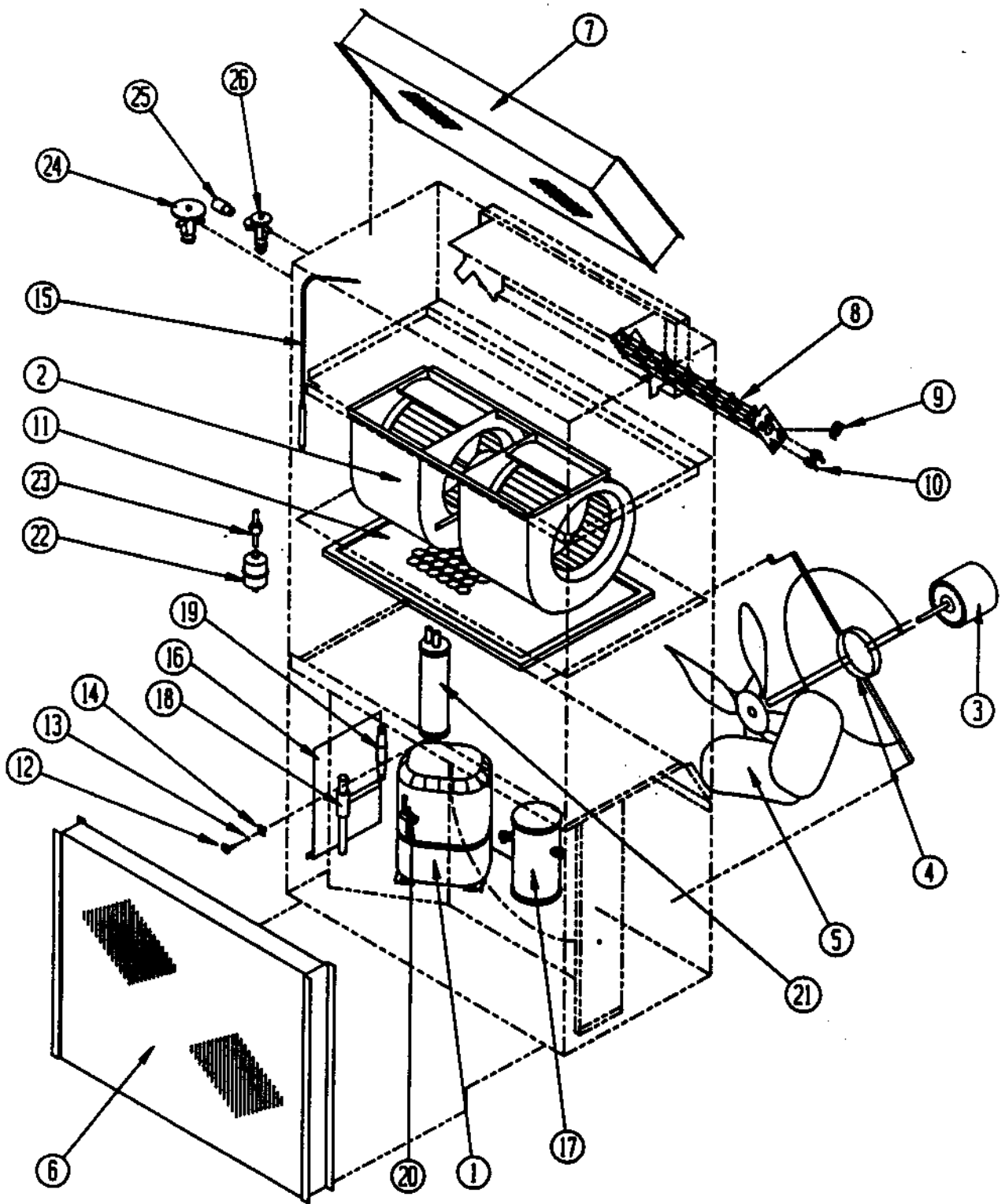

Date: 7-11-89
Supersedes:

FUNCTIONAL COMPONENTS

Dwg. No.	Part No.	Description	4 9 W A E O N	4 9 W A E 1 5 N	4 9 W A F O N	4 9 W A F 1 4 N	4 9 W A G O N	4 9 W A G 1 5 N
1	8000-026	Compressor						
1	8000-064	Compressor	X	X			X	X
1	8000-065	Compressor			X	X		
2	900-119	Blower Assembly (Complete)	X	X	X	X	X	X
3	8105-014	Condenser Motor	X	X	X	X	X	X
4	8200-004	Motor Mount--Condenser	X	X	X	X	X	X
5	5151-026	Fan Blade	X	X	X	X	X	X
6	5051-028	Condenser Coil	X	X	X	X	X	X
7	5060-025	Evaporator Coil	X	X	X	X	X	X
8	8604-087	Heat Strip				X		
8	8604-047	Heat Strip		X				X
9	8402-047	Limit Control		X		X		X
10	8402-032	Thermal Cutoff 4K9239H		3		4		3
11	7004-016	Air Filter 20 x 30 x 1	X	X	X	X	X	X
12	1171-019	1/4 Turn Fastener	X	X	X	X	X	X
13	1171-021	Retainer Washer	X	X	X	X	X	X
14	1171-020	Receptacle	X	X	X	X	X	X
15	800-0093	Cooling Capillary Assembly	X	X	X	X	X	X

Date: 7-11-89
Supersedes:

CONTROL PANEL WITHOUT CIRCUIT BREAKER

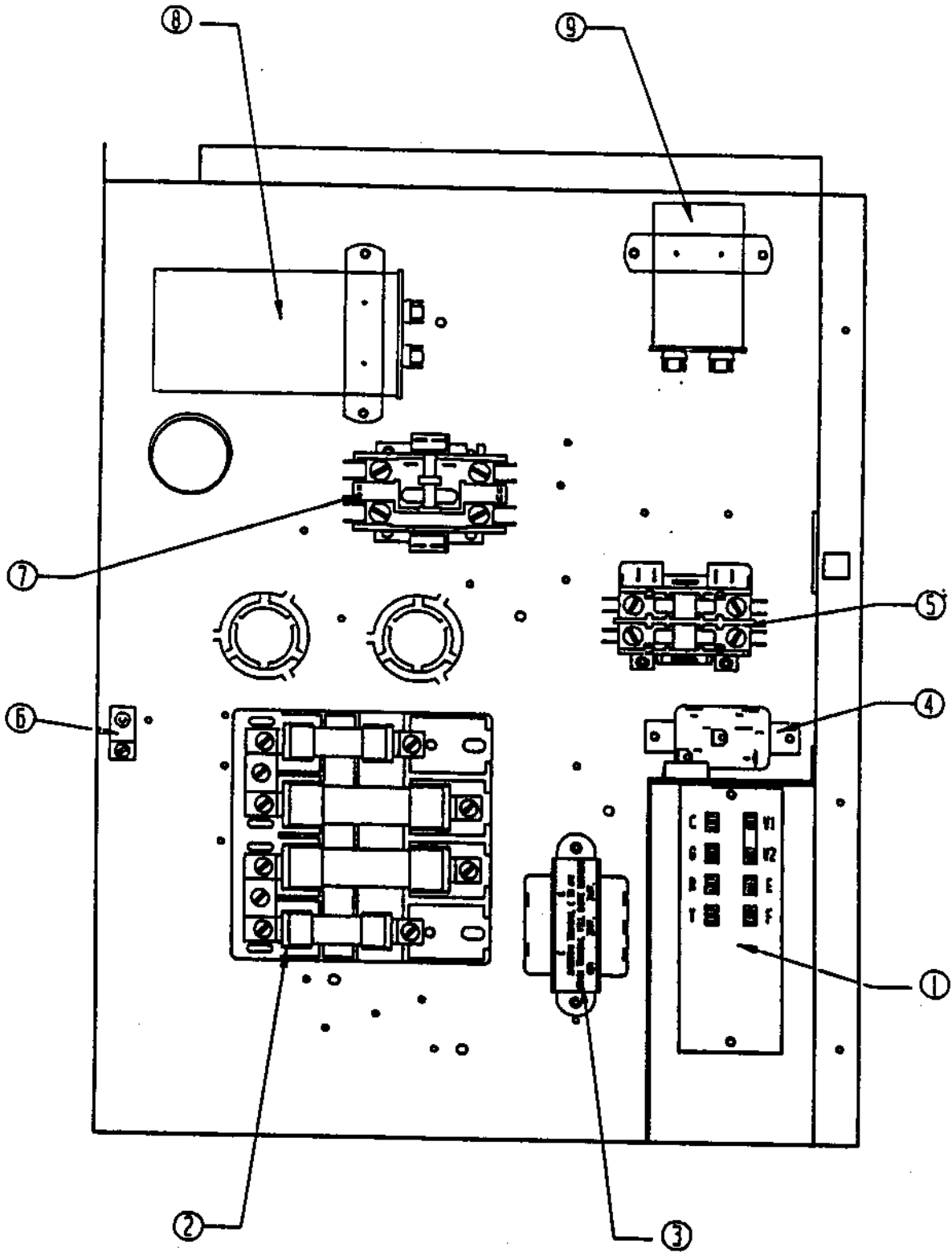

Date: 7-11-89
Supersedes:

CONTROL PANEL
WITHOUT CIRCUIT BREAKER

Dwg. No.	Part No.	Description	49WA-00N, H	49WA-01N, H	49WA-015N, N	49WA-020N, H	49WA-000B, N, H	49WA-009B, N, H	49WA-015B, N, H	49WA-018B, N, H	49WA-000C, N, H	49WA-009C, N, H	49WA-015C, N, H
1	8607-018	Low Voltage Strip	X	X	X	X	X	X	X	X	X	X	X
2	8607-013	Terminal Block	X	X			X	X	X	X	X	X	X
2	8607-014	Terminal Block					X	X	X	X	X	X	X
2	8614-017	Fuse Block			X								
2	8614-018	Fuse Block				X							
3	8407-034	Transformer	X	X	X	X	X	X	X				
3	8407-027	Transformer									X	X	X
4	8201-009	Blower Relay	X	X	X	X	X	X	X				
4	8201-032	Blower Relay									X	X	X
5	8401-006	Heat Contactor		X	2	2		X	2	2			
5	8401-002	Heat Contactor											
6	8611-006	Ground Terminal	X	X	X	X	X	X	X	X	X	X	X
7	8401-003	Compressor Contactor	X	X	X	X							
7	8401-002	Compressor Contactor					X	X	X	X	X	X	X
8	8552-030	Compressor Capacitor 40/440	X	X	X	X							
9	8552-005	Condenser Fan Capacitor 10/370					X	X	X	X	X	X	X
9	8552-026	Condenser Fan Capacitor 15/370									X	X	X
10	8607-015	Phenolic Insulator									X	X	X
	4010-110	Wiring Diagram	X										
	4010-130	Wiring Diagram		X									
	4010-140	Wiring Diagram			X								
	4010-150	Wiring Diagram				X							
	4010-210	Wiring Diagram					X						
	4010-220	Wiring Diagram						X					
	4010-230	Wiring Diagram							X				
	4010-240	Wiring Diagram								X			
	4010-310	Wiring Diagram									X		
	4010-320	Wiring Diagram										X	
	4010-330	Wiring Diagram											X
	132-081	Control Panel Cover	X	X			X	X	X	X	X	X	X
	133-054	Control Panel Cover			X	X							

Date: 7-11-89
Supersedes:

CONTROL PANEL WITHOUT CIRCUIT BREAKER

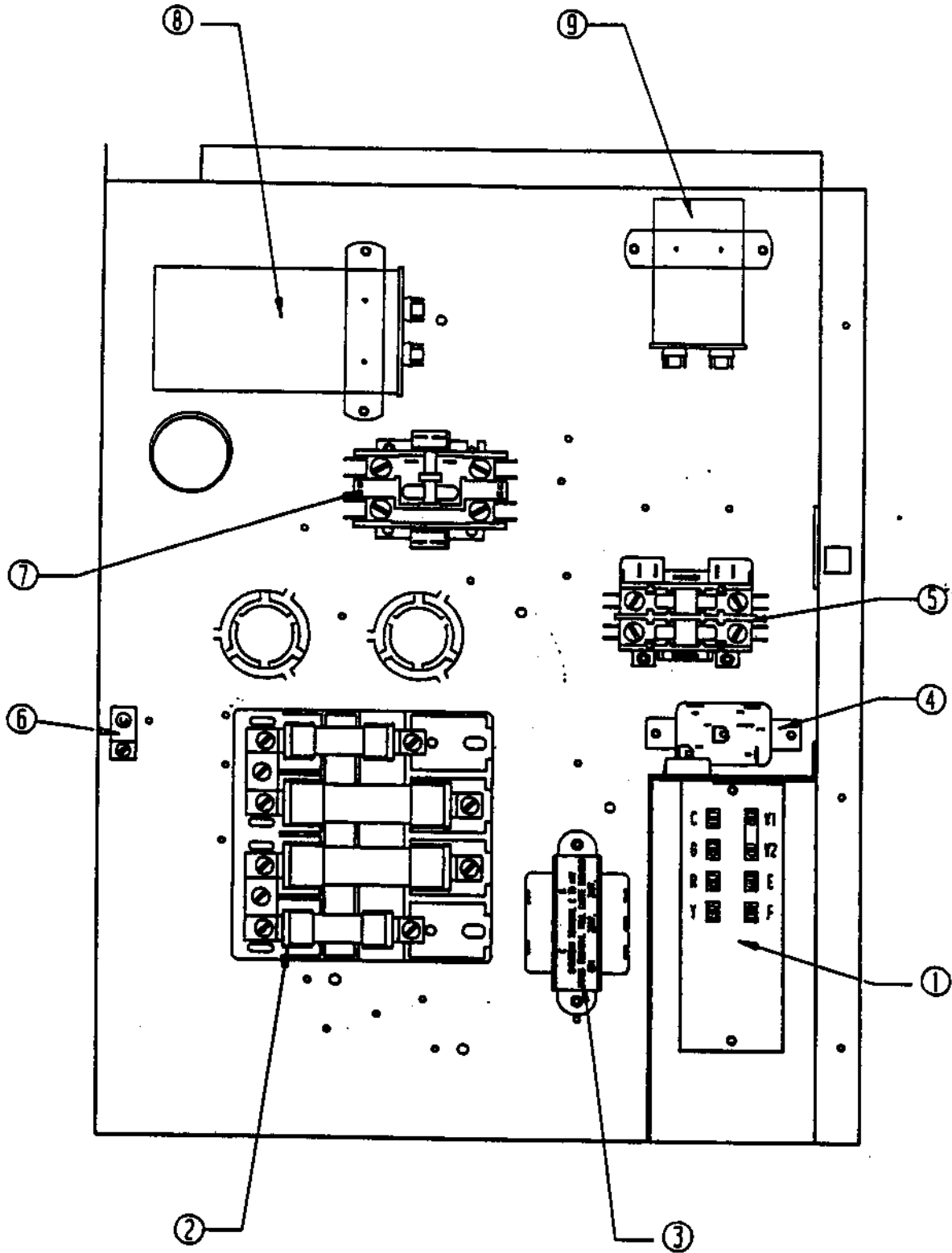

Date: 7-11-89
Supersedes:

CONTROL PANEL
WITHOUT CIRCUIT BREAKER

Dwg. No.	Part No.	Description	4 9 W A E O O N	4 9 W A E 1 5 O N	4 9 W A F O O N	4 9 W A F 1 4 O N	4 9 W A G O O N	4 9 W A G 1 5 N
1	8607-018	Low Voltage Strip	X	X	X	X	X	X
2	8607-013	Terminal Block			2	2	X	
2	8607-014	Terminal Block	X	X				
2	8614-017	Fuse Block						X
3	8407-034	Transformer	X	X	X	X	X	X
4	8201-009	Blower Relay	X	X	X	X	X	X
5	8401-006	Heat Contactor		2				2
5	8401-002	Heat Contactor				2		
6	8611-006	Ground Terminal	X	X	X	X	X	X
7	8401-016	Compressor Contactor					X	X
7	8401-002	Compressor Contactor	X	X	X	X		
8	8552-030	Compressor Capacitor 40/440					X	X
9	8552-005	Condenser Fan Capacitor 10/370	X	X	X	X	X	X
10	---							
	4010-410	Wiring Diagram					X	
	4010-440	Wiring Diagram						X
	4010-510	Wiring Diagram	X					
	4010-530	Wiring Diagram		X				
	4010-610	Wiring Diagram			X			
	4010-630	Wiring Diagram				X		
	132-081	Control Panel Cover	X	X	X	X	X	
	133-054	Control Panel Cover						X

Date: 7-11-89
Supersedes:

CONTROL PANEL WITH CIRCUIT BREAKER

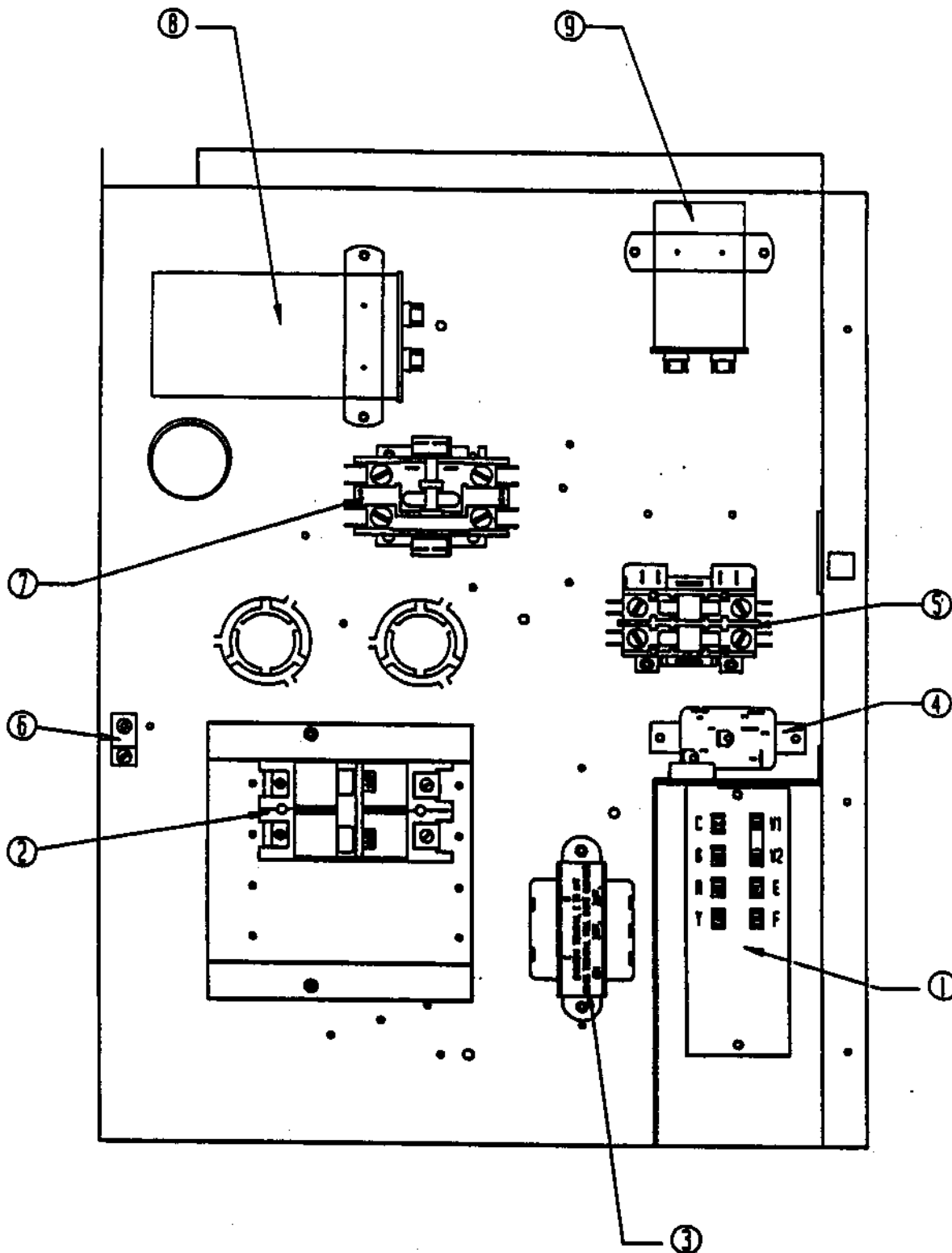

Date: 7-11-89
Supersedes:

CONTROL PANEL
WITH CIRCUIT BREAKER

Dwg. No.	Part No.	Description	4	4	4	4	4	4	4	4	4	4	4
			9	9	9	9	9	9	9	9	9	9	9
			W	W	W	W	W	W	W	W	W	W	W
			A	A	A	A	A	A	A	A	A	A	A
			A	A	A	A	B	B	B	B	C	C	C
			O	O	O	O	O	O	O	O	O	O	O
			O	I	1	2	0	0	9	5	8	0	9
			C	C	C	C	C	C	C	C	C	C	C
1	8607-018	Low Voltage Terminal Strip	X	X	X	X	X	X	X	X	X	X	X
2	8615-015	Circuit Breaker 50A	X										
2	8615-016	Circuit Breaker 60A		X		2							
2	8615-016	Circuit Breaker 30A			X								
2	8615-019	Circuit Breaker 35A					X	X					
2	8615-011	Circuit Breaker 60A							X	X			
2	8615-030	Circuit Breaker 20A									X	X	
2	8615-032	Circuit Breaker 30A											X
3	8407-034	Transformer	X	X	X	X	X	X	X	X			
3	8407-027	Transformer									X	X	X
4	8201-009	Blower Relay	X	X	X	X	X	X	X	X			
4	8201-032	Blower Relay									X	X	X
5	8401-006	Heat Contactor		X	2	2		X	2	2			
5	8401-002	Heat Contactor										X	X
6	8611-006	Ground Terminal	X	X	2	2	X	X	X	X	X	X	X
7	8401-003	Compressor Contactor	X	X	X	X					X	X	X
7	8401-002	Compressor Contactor					X	X	X	X	X	X	X
8	8552-030	Compressor Capacitor 40/440											
9	8552-005	Condenser Fan Capacitor 10/370					X	X	X	X			
9	8552-026	Condenser Fan Capacitor 15/370									X	X	X
	4010-111	Wiring Diagram	X										
	4010-131	Wiring Diagram		X									
	4010-141	Wiring Diagram			X								
	4010-151	Wiring Diagram				X							
	4010-211	Wiring Diagram					X						
	4010-221	Wiring Diagram						X					
	4010-231	Wiring Diagram							X				
	4010-241	Wiring Diagram								X			
	4010-311	Wiring Diagram									X		
	4010-321	Wiring Diagram										X	
	4010-331	Wiring Diagram											X
	132-092	Control Panel Cover	X	X	X	X	X	X	X	X	X	X	X
	132-094	Control Panel Cover											

Date: 7-11-89
Supersedes:

BLOWER ASSEMBLY

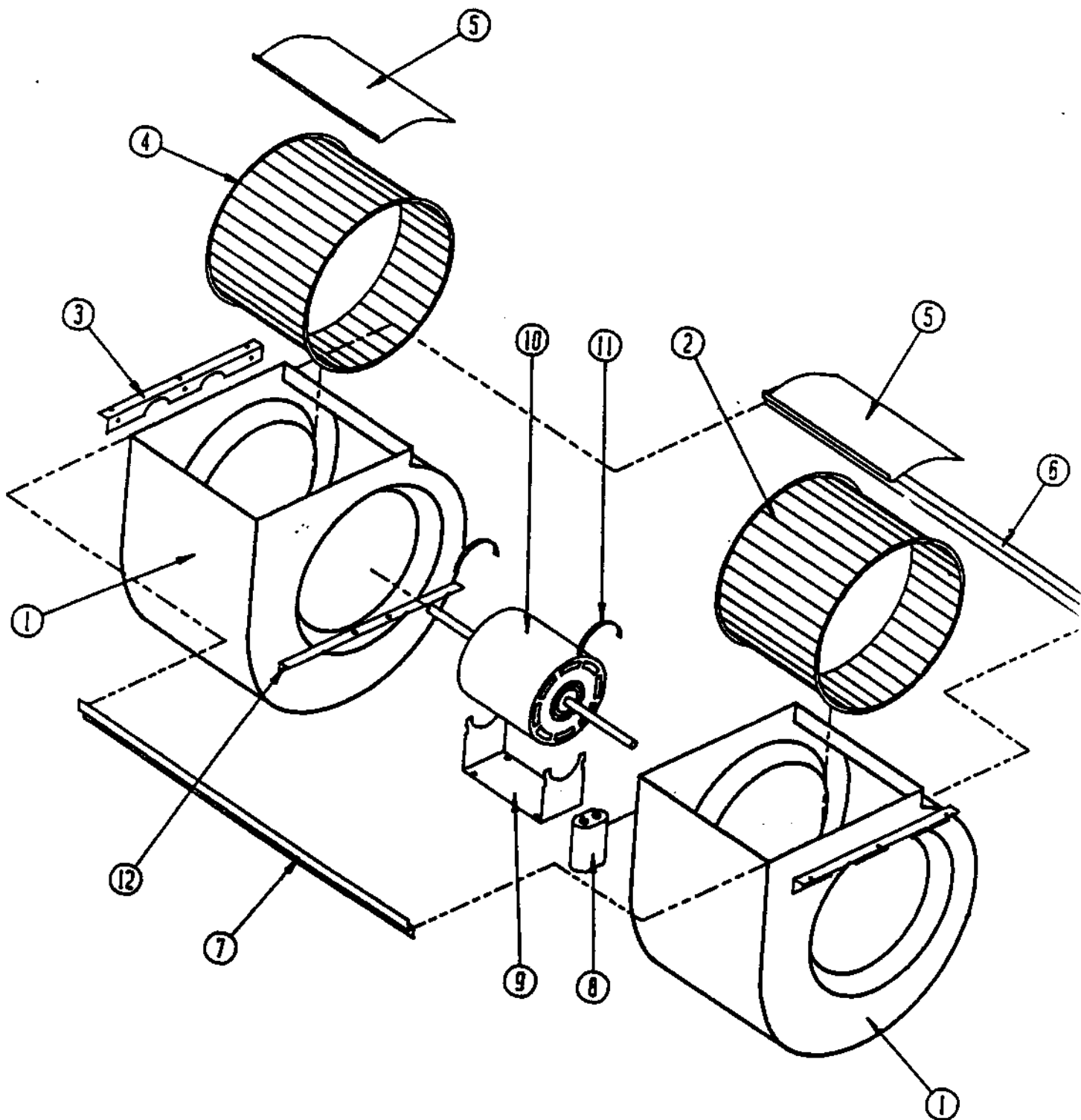

Date: 7-11-89
Supersedes:

BLOWER ASSEMBLY

Dwg. No.	Part No.	Description	9 0 0 1 1 9	9 0 0 1 2 0	9 0 0 1 2 1
1	151-068	Blower Housing	2	2	2
2	5152-011	Blower Wheel 10-8, CW	x	x	
2	5152-057	Blower Wheel 9-8, CW			x
3	104-791	Blower Angle	2	2	2
4	5152-012	Blower Wheel 10-8, CCW	x	x	
4	5152-058	Blower Wheel 9-8, CCW			x
5	144-126	Diffuser	2	2	2
6	104-802	Back Brace	x	x	x
7	102-389	Front Offset	x	x	x
8	8552-005	Capacitor 10/370	x	x	x
9	128-002	Motor Mount--Cradle	x	x	x
10	8106-023	Motor	x		x
10	8106-024	Motor		x	
11	8200-018	Motor Mount Latch	2	2	2
12	104-788	Motor Support Angle	2	2	2

Date: 7-11-89
Supersedes: