

REPLACEMENT PARTS MANUAL

WALL MOUNTED PACKAGE AIR CONDITIONER MODEL 36WA6

Manual 2110-404

Revision A

Date 1-25-90

Supersedes 7-11-89

* GENERAL NOTES *

*Revised and/or additional pages may be issued from time to time.
*A complete and current manual consists of pages dated as shown in the following index.

** INDEX **

<u>Page Description</u>	<u>Page</u>	<u>Date</u>	<u>Supersedes</u>
Cabinet Components--Exploded View	1	7-11-89	
" " --Usage List	2	1-25-90	7-11-89
Functional Components--Exploded View	3	7-11-89	
" " --Usage List	4	7-11-89	
Functional Components--Exploded View	5	7-11-89	
" " --Usage List	6	7-11-89	
Control Panel W/O Circuit Breaker--Layout	7	7-11-89	
" " --Usage List	8	7-11-89	
Control Panel W/Circuit Breaker--Layout	9	7-11-89	
" " " --Usage List	10	1-25-90	7-11-89
Blower Assembly--Exploded View	11	7-11-89	
" " --Usage List	12	7-11-89	

*** IMPORTANT ***

Contact the installing and/or local Bard distributor for all parts requirements. Make sure you have the complete model and serial number available from the unit rating plate.

BARD MANUFACTURING COMPANY

BRYAN, OHIO 43506

CABINET COMPONENTS

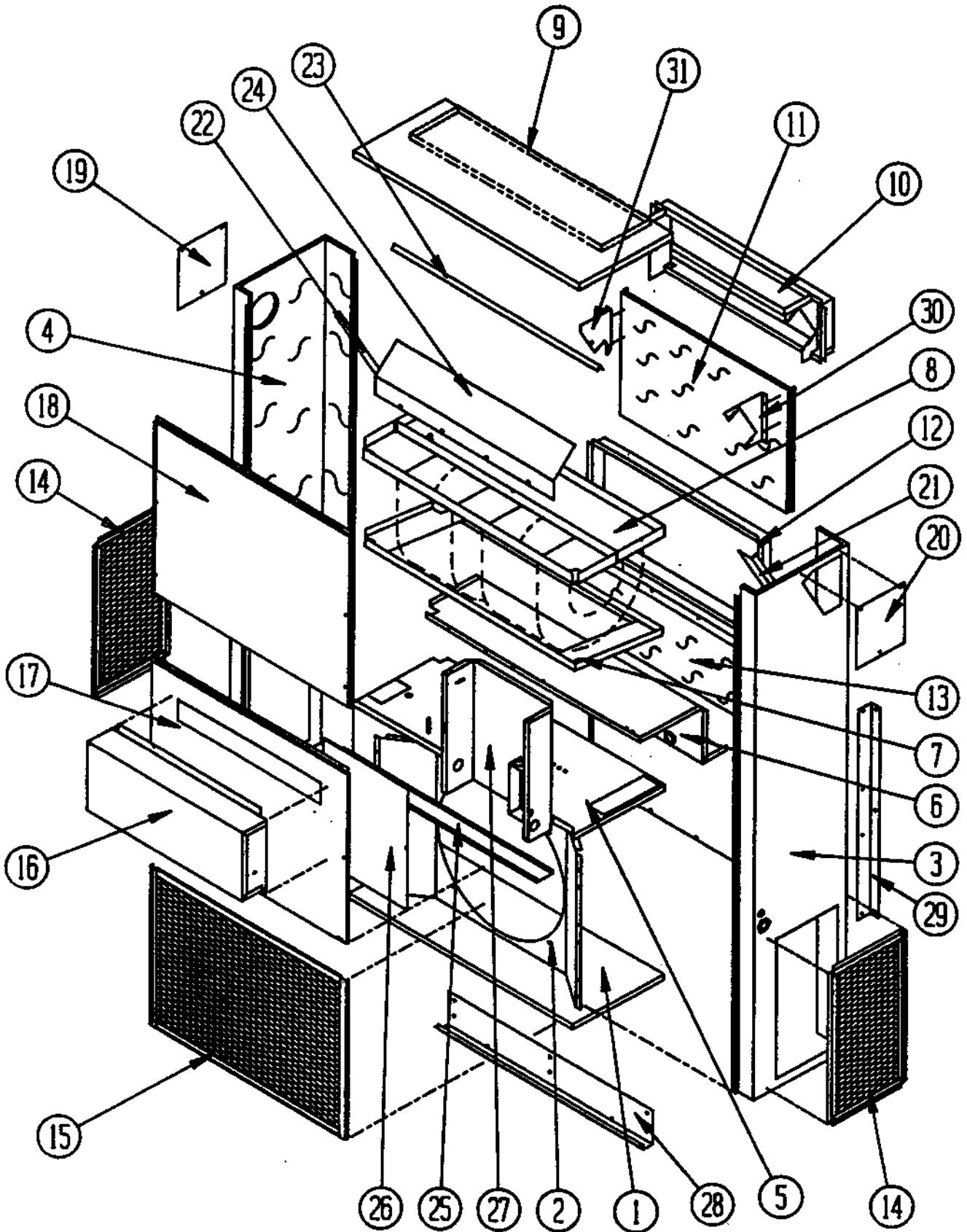

Date: 7-11-89
Supersedes:

CABINET COMPONENTS

Dwg. No.	Part No.	Description	S T A N D A R D	T O P O U T L E T
1	126-003	Lower Base	X	X
2	124-002	Fan Shroud	X	X
3	501-164	Right Side	X	X
4	501-165	Left Side	X	X
5	127-098	Compressor Base	X	X
6	520-097	Compressor Partition	X	X
7	131-002	Filter Tray	X	X
8	521-004	Blower Addition/Drain Pan Assembly	X	X
9	506-095	Top	X	
9	507-003	Top		X
10	111-017	Outlet Airframe Assembly	X	
11	508-056	Upper Back	X	
11	508-058	Extended Upper Back		X
12	111-018	Inlet Air Frame Assembly	X	X
13	508-057	Lower Back	X	X
14	119-004	Side Grille	2	2
15	119-003	Condenser Grille	X	X
16	962002	Fresh Air Damper Assembly	X	X
17	552-107	Service Door	X	X
18	514-046	Upper Front	X	X
19	542Y004	Left Side Cover Plate	X	X
20	542X004	Right Side Cover Plate	X	X
21	141-006	Right Evaporator Support	X	X
22	141-007	Left Evaporator Support	X	X
23	136-093	Evaporator Fill Plate	X	X
24	134-008	Air Baffle	X	X
25	136-002	Condenser Coil Spacer	X	X
26	Cntrl.Cvr.	See Control Panel Assembly Drawing and Parts List	X	X
27	Cntrl.Pnl. Assembly	See Control Panel Assembly Drawing and Parts List	X	X
28	112-006	Bottom Mounting Bracket	X	X
29	112-002	Side Mounting Bracket	2	2
30	112-007	Right Heat Strip Bracket		X
31	112-008	Left Heat Strip Bracket		X

Date: 1-25-90
Supersedes: 7-11-89

FUNCTIONAL COMPONENTS

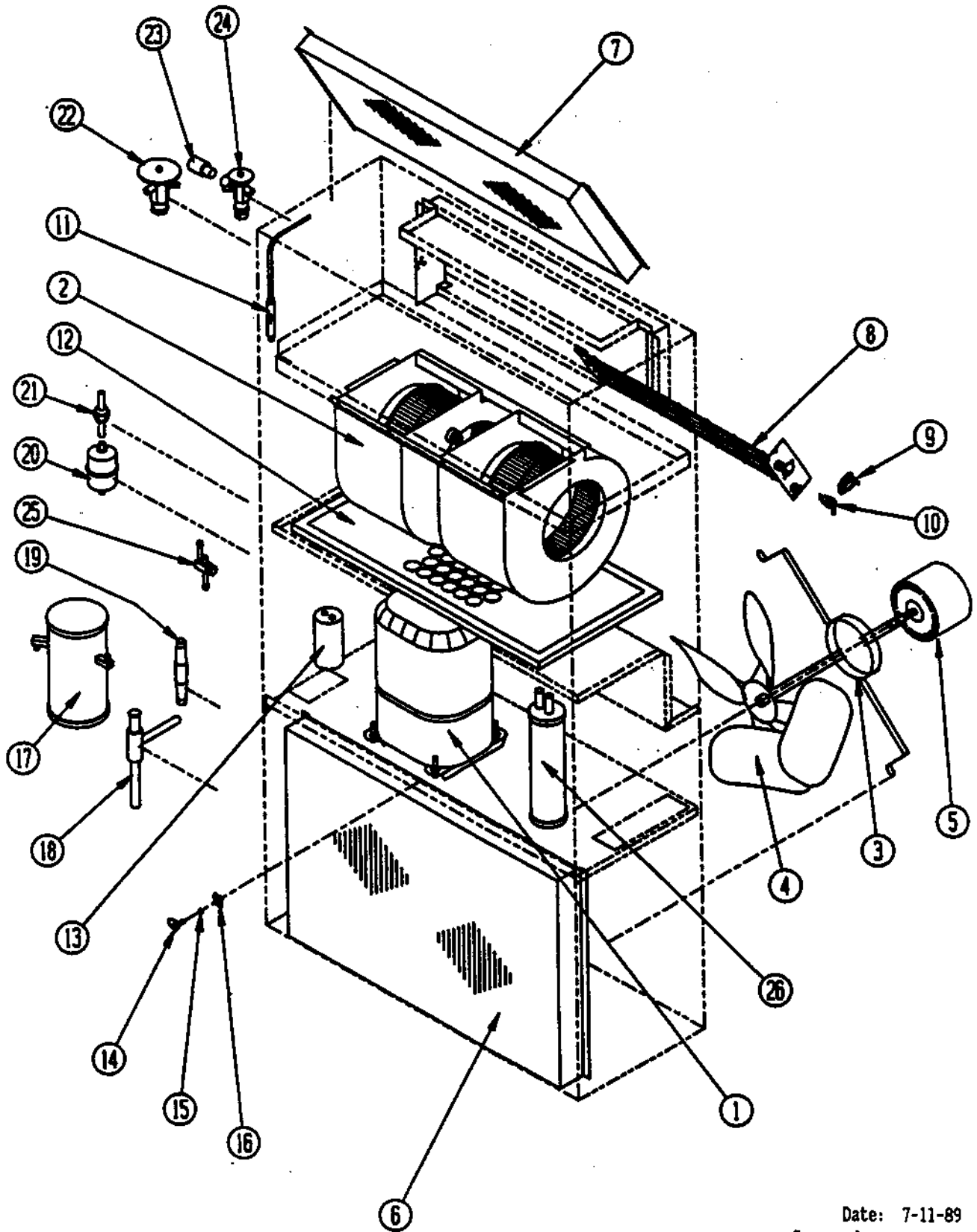

Date: 7-11-89
Supersedes:

FUNCTIONAL COMPONENTS

Dwg. No.	Part No.	Description	3 6 W A 6 A O O N, C	3 6 W A 6 A O 5 N, C	3 6 W A 6 A O 8 N, C	3 6 W A 6 A O 1 0 N, C	3 6 W A 6 A O 1 5 N, C	3 6 W A 6 B O 0 N, C	3 6 W A 6 B O 6 N, C	3 6 W A 6 B O 9 N, C	3 6 W A 6 B O 1 2 N, C	3 6 W A 6 B O 1 5 N, C	3 6 W A 6 C O 0 N, C	3 6 W A 6 C O 9 N, C	3 6 W A 6 C O 1 5 N, C	3 6 W A 6 D O 1 0 N	3 6 W A 6 E O 0 N	3 6 W A 6 E O 9 N	3 6 W A 6 F O 9 N
1	8000-039	Compressor														X			
1	8000-058	Compressor CRJ3-0300-PFV	X	X	X	X	X												
1	8000-059	Compressor CRJ3-0300-TF5						X	X	X	X	X						X	X
1	8000-060	Compressor CRJ3-0300-TFD											X	X	X				
2	900-039	Blower Assembly (Complete)	X	X	X	X	X	X	X	X	X	X					X	X	X
2	900-070	Blower Assembly (Complete)											X	X	X				
3	8200-001	Motor Mount (Condenser)	X	X	X	X	X	X	X	X	X	X	X	X	X	X	X	X	X
4	5151-032	Fan Blade	X	X	X	X	X	X	X	X	X	X	X	X	X				
5	8103-019	Condenser Motor	X	X	X	X	X	X	X	X	X	X					X	X	X
5	8103-014	Condenser Motor											X	X	X				
6	5051-035	Condenser Coil	X	X	X	X	X	X	X	X	X	X	X	X	X	X	X	X	X
7	5060-037	Evaporator Coil	X	X	X	X	X	X	X	X	X	X	X	X	X	X	X	X	X
8	8604-051	Heat Strip																	X
8	8604-089	Heat Strip		X															
8	8604-090	Heat Strip			X														
8	8604-091	Heat Strip				X											X		
8	8604-047	Heat Strip					X					X							
8	8604-049	Heat Strip						X											
8	8604-048	Heat Strip							X										X
8	8604-046	Heat Strip								X									
8	8604-072	Heat Strip											X	X					
8	8604-079	Heat Strip												X	X				
9	8402-031	Limit Control		X	X	X	X		X	X	X	X				X			X
9	8402-060	Limit Control												X	X				
10	8402-032	Thermal Cut-Off		X	2	2	3		2	2	3	3				2		2	3
10	8402-059	Thermal Cut-Off												2	4				
11	800-0070	Cooling Capillary Assembly	X	X	X	X	X	X	X	X	X	X	X	X	X	X	X	X	X
12	7004-008	Air Filter	X	X	X	X	X	X	X	X	X	X	X	X	X	X	X	X	X
13	8552-028	Compressor Capacitor	X	X	X	X	X									X			
14	1171-019	1/4 Turn Fastener	X	X	X	X	X	X	X	X	X	X	X	X	X	X	X	X	X
15	1171-021	1/4 Turn Fastener Retainer	X	X	X	X	X	X	X	X	X	X	X	X	X	X	X	X	X
16	1171-020	1/4 Turn Fastener Receptacle	X	X	X	X	X	X	X	X	X	X	X	X	X	X	X	X	X

Date: 7-11-89
Supersedes:

FUNCTIONAL COMPONENTS

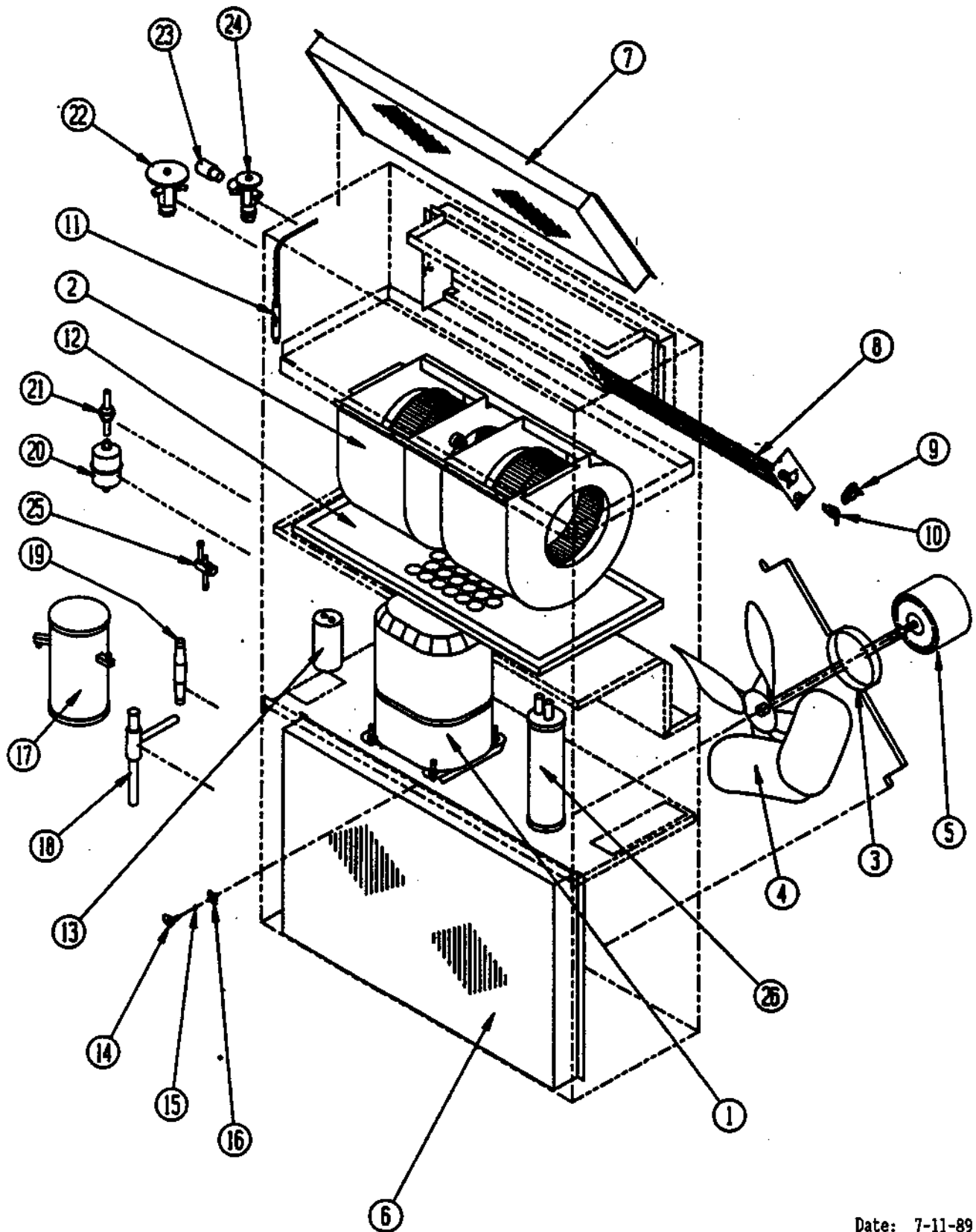

Date: 7-11-89
Supersedes:

FUNCTIONAL COMPONENTS

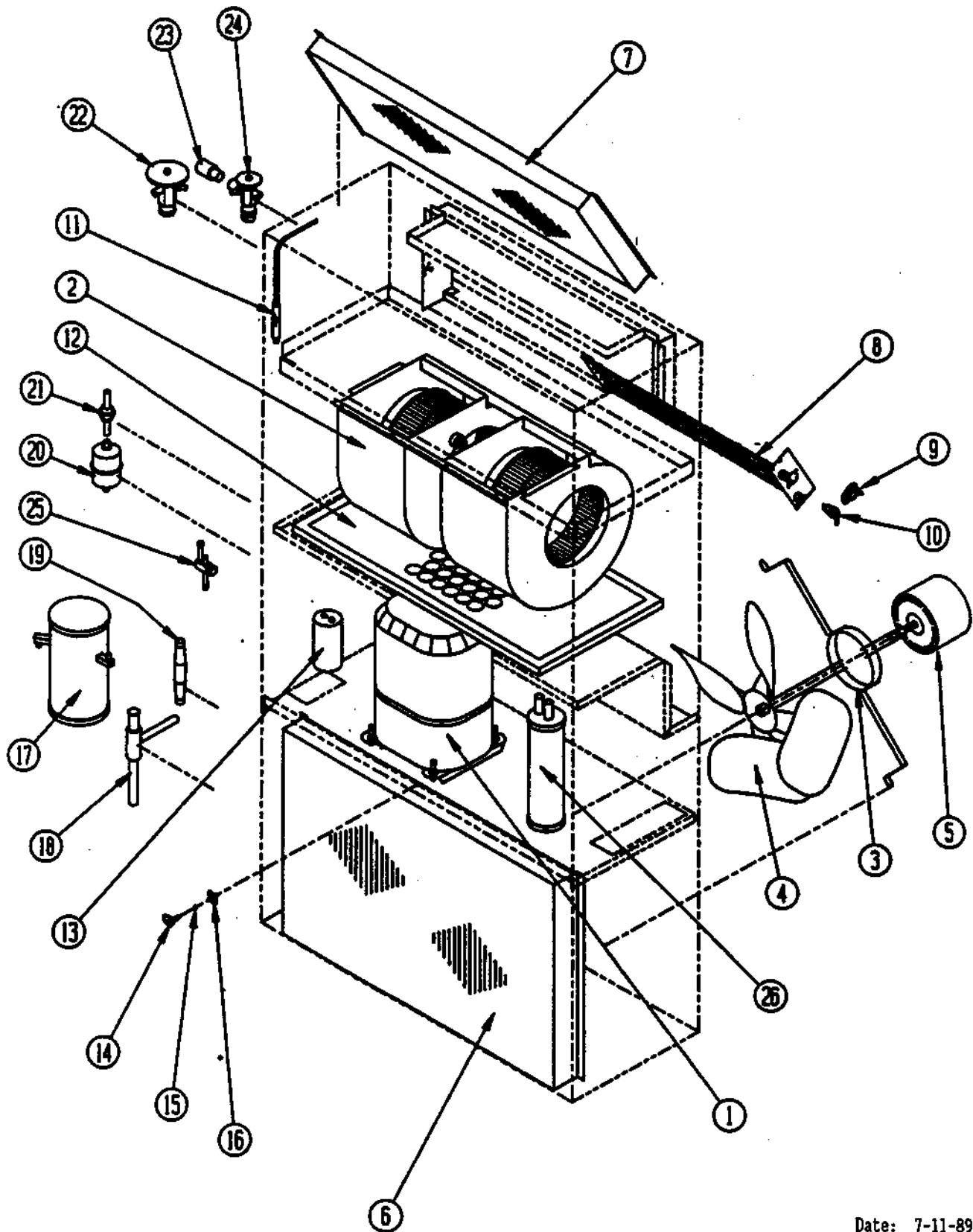

Date: 7-11-89
Supersedes:

FUNCTIONAL COMPONENTS

Dwg. No.	Part No.	Description	3	3	3	3	3	3	3	3	3	3	3	3	3
			6	6	6	6	6	6	6	6	6	6	6	6	6
			W	W	W	W	W	W	W	W	W	W	W	W	W
			A	A	A	A	A	A	A	A	A	A	A	A	A
			6	6	6	6	6	6	6	6	6	6	6	6	6
			A	A	B	B	C	C	A	A	A	B	B	B	B
			O	O	O	O	O	O	O	O	O	O	O	O	O
			H	H	H	H	H	H	T	T	T	T	T	T	T
1	8000-058	Compressor CRJ3-0300-PFV	X	X					X	X	X	X			
1	8000-059	Compressor CRJ3-0300-TF5			X	X							X	X	X
1	8000-060	Compressor CRJ3-0300-TFD					X	X							
2	900-039	Blower Assembly (Complete)	X	X	X	X			X	X	X	X	X	X	X
2	900-070	Blower Assembly (Complete)					X	X							
3	8200-001	Motor Mount (Condenser)	X	X	X	X	X	X	X	X	X	X	X	X	X
4	5151-032	Fan Blade	X	X	X	X	X	X	X	X	X	X	X	X	X
5	8103-019	Condenser Motor	X	X	X	X			X	X	X	X	X	X	X
5	8103-014	Condenser Motor					X	X							
6	5051-035	Condenser Coil	X	X	X	X	X	X	X	X	X	X	X	X	X
7	5060-037	Evaporator Coil	X	X	X	X	X	X	X	X	X	X	X	X	X
8	8604-089	Heat Strip							X						
8	8604-091	Heat Strip		X						X					
8	8604-047	Heat Strip									X				X
8	8604-048	Heat Strip				X								X	
8	8604-072	Heat Strip													
8	8604-079	Heat Strip						2							
9	8402-031	Limit Control		X		X			X	X	X			X	X
9	8402-060	Limit Control						X							
10	8402-030	Thermal Cut-Off							X	2	3			2	3
10	8402-032	Thermal Cut-Off		2		2									
10	8402-059	Thermal Cut-Off						4							
11	800-0070	Cooling Capillary Assembly	X	X	X	X	X	X	X	X	X	X	X	X	X
12	7004-008	Air Filter	X	X	X	X	X	X	X	X	X	X	X	X	X
13	8552-028	Compressor Capacitor	X	X					X	X	X	X			
14	1171-019	1/4 Turn Fastener	X	X	X	X	X	X	X	X	X	X	X	X	X
15	1171-021	1/4 Turn Fastener Retainer	X	X	X	X	X	X	X	X	X	X	X	X	X
16	1171-020	1/4 Turn Fastener Receptacle	X	X	X	X	X	X	X	X	X	X	X	X	X
17	5203-004	Receiver	X	X	X	X	X	X							
18	5651-015	Head Pressure Control Valve	X	X	X	X	X	X							
19	5651-016	Pressure Differential Valve	X	X	X	X	X	X							
20	5201-001	Filter Drier	X	X	X	X	X	X							
21	5201-014	Sight Glass	X	X	X	X	X	X							
22	5651-064	Hot Gas Bypass Valve	X	X	X	X	X	X							
23	5651-026	Distributor	X	X	X	X	X	X							
24	5651-039	Expansion Valve	X	X	X	X	X	X							
25	5651-051	Shutoff Valve	X	X	X	X	X	X							
26	5202-016	Accumulator	X	X	X	X	X	X							

Date: 7-11-89
Supersedes:

CONTROL PANEL WITHOUT CIRCUIT BREAKERS

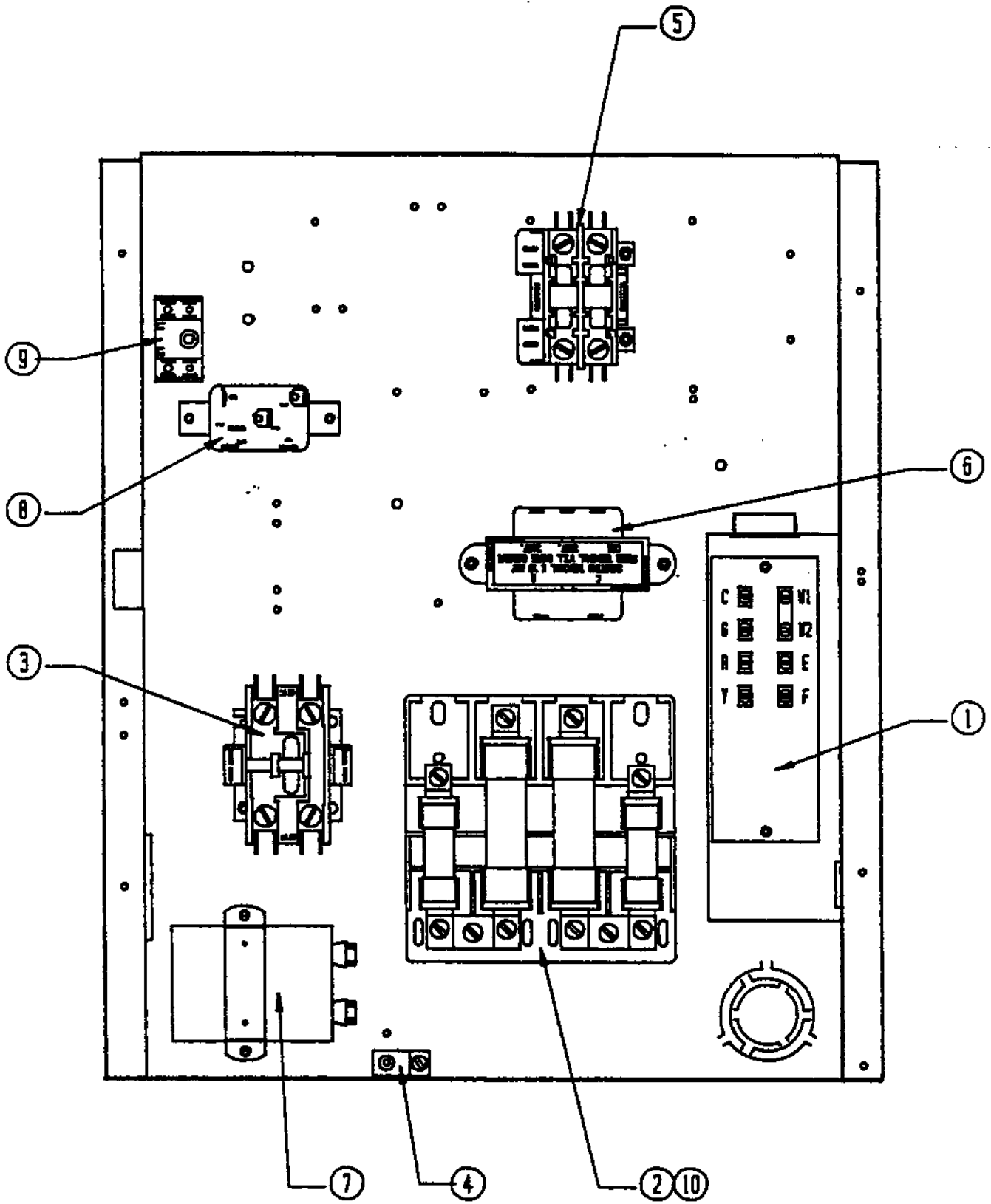

Date: 7-11-89
Supersedes:

CONTROL PANEL
WITHOUT CIRCUIT BREAKERS

Dwg. No.	Part No.	Description	3	3	3	3	3	3	3	3	3	3	3	3	3	3	3	3	3
			W	W	W	W	W	W	W	W	W	W	W	W	W	W	W	W	W
			A	A	A	A	A	A	A	A	A	A	A	A	A	A	A	A	
			6	6	6	6	6	6	6	6	6	6	6	6	6	6	6	6	
			A	A	A	A	A	B	B	B	B	C	C	C	D	E	E	F	
			O	O	O	O	O	O	O	O	O	O	O	O	O	O	O	O	
			N,	N,	N	N,	N,	N,	N,	N,	N	N	N	N	N	N	N	N	
			H,	T,		H,	T	H,	T	H,	T	H	H	H	H	H	H		
1	8607-018	Low Voltage Terminal Strip	X	X	X	X	X	X	X	X	X	X	X	X	X	X	X	X	
2	8607-013	Terminal Block		X	X	X												2	
2	8614-017	Fuse Block					X												
2	8607-014	Terminal Block						X	X	X	X		X	X			X		
3	8401-007	Compressor Contactor	X	X	X	X	X									X			
3	8401-002	Compressor Contactor						X	X	X	X	X	X	X		X	X	X	
4	8611-006	Ground Terminal	X	X	X	X	X	X	X	X	X	X	X	X	X	X	X	X	
5	8401-006	Heat Contactor		X	X	X	2		X	X	2	2				X		X	
5	8401-002	Heat Contactor										X	2	2				X	
6	8407-034	Transformer	X	X	X	X	X	X	X	X	X					X	X	X	
6	8407-027	Transformer										X	X	X	X			X	
7	8552-002	Condenser Motor Capacitor	X	X	X	X	X	X	X	X	X	X	X	X	X	X	X	X	
8	8201-009	Blower Relay	X	X	X	X	X	X	X	X	X					X	X	X	
8	8201-032	Blower Relay										X	X	X	X				
9	8607-017	Terminal Block										X	X	X	X				
10	134-051	Terminal Block Barrier																X	
10	8607-015	Phenolic Insulator										X	X	X					
	4009-110	Wiring Diagram	X																
	4009-120	Wiring Diagram		X															
	4009-130	Wiring Diagram			X	X													
	4009-140	Wiring Diagram					X												
	4009-210	Wiring Diagram						X											
	4009-220	Wiring Diagram						X	X										
	4009-230	Wiring Diagram								X	X								
	4009-310	Wiring Diagram									X								
	4009-320	Wiring Diagram										X							
	4009-332	Wiring Diagram											X						
	4009-420	Wiring Diagram												X					
	4009-510	Wiring Diagram													X				
	4009-520	Wiring Diagram														X			
	4009-620	Wiring Diagram															X	X	
	132-003	Control Panel Cover	X	X	X	X		X	X	X	X	X	X	X	X	X	X	X	
	133-036	Control Panel Cover					X												

Date: 7-11-89
Supersedes:

CONTROL PANEL WITH CIRCUIT BREAKER

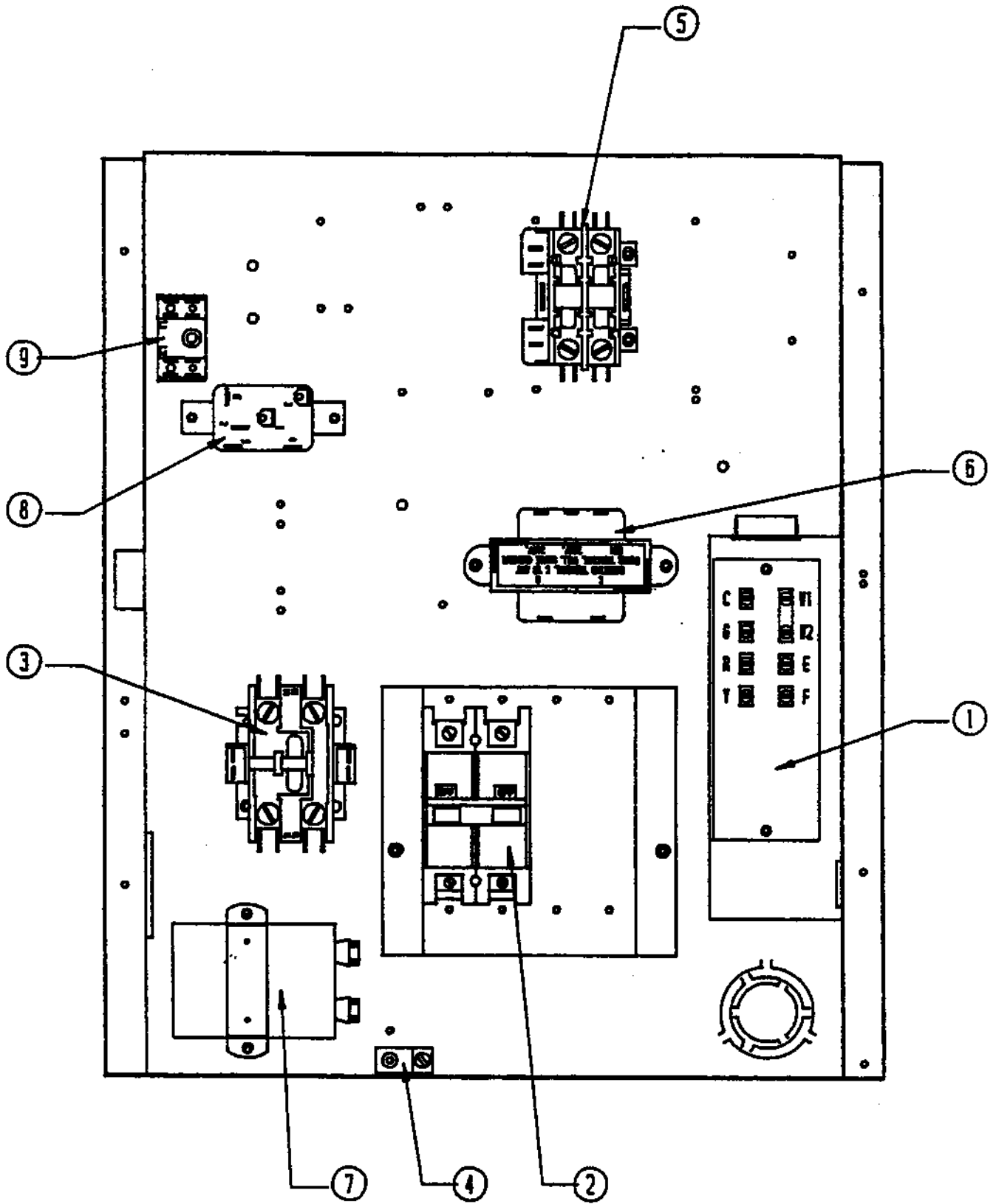

Date: 7-11-89
Supersedes:

**CONTROL PANEL
WITH CIRCUIT BREAKER**

Dwg. No.	Part No.	Description	36WA6A00C	36WA6A05C	36WA6A08C	36WA6A01C	36WA6A05C	36WA6A06C	36WA6A06C	36WA6A09C	36WA6A02C	36WA6A05C	36WA6A00C	36WA6A09C	36WA6A05C
1	8607-018	Low Voltage Terminal Strip	X	X	X	X	X	X	X	X	X	X	X	X	X
2	8615-010	Circuit Breaker	X	X	X										
2	8615-029	Circuit Breaker											X	X	
2	8615-016	Circuit Breaker				X	X								
2	8615-013	Circuit Breaker					X								
2	8615-019	Circuit Breaker						X	X	X					
2	8615-020	Circuit Breaker									X				
2	8615-007	Circuit Breaker										X			
2	8615-031	Circuit Breaker													X
3	8401-007	Compressor Contactor	X	X	X	X	X								
3	8401-002	Compressor Contactor						X	X	X	X	X	X	X	X
4	8611-006	Ground Terminal	X	X	X	X	2	X	X	X	X	X	X	X	X
5	8401-006	Heat Contactor		X	X	X	2		X	X	2	2			
5	8401-002	Heat Contactor												X	2
6	8407-034	Transformer	X	X	X	X	X	X	X	X	X	X			
6	8407-027	Transformer											X	X	X
7	8552-002	Condenser Motor Capacitor	X	X	X	X	X	X	X	X	X	X	X	X	X
8	8201-009	Blower Relay	X	X	X	X	X	X	X	X	X	X			
8	8201-032	Blower Relay											X	X	X
9	8607-017	Terminal Block											X	X	X
	4009-111	Wiring Diagram	X												
	4009-121	Wiring Diagram		X											
	4009-131	Wiring Diagram			X	X									
	4009-141	Wiring Diagram					X								
	4009-211	Wiring Diagram						X							
	4009-221	Wiring Diagram							X	X					
	4009-231	Wiring Diagram									X	X			
	4009-311	Wiring Diagram											X		
	4009-321	Wiring Diagram												X	
	4009-333	Wiring Diagram													X
	132-050	Control Panel Cover											X	X	X
	132-098	Control Panel Cover	X	X	X	X	X	X	X	X	X	X			

Date: 1-25-90
Supersedes: 7-11-89

BLOWER ASSEMBLY

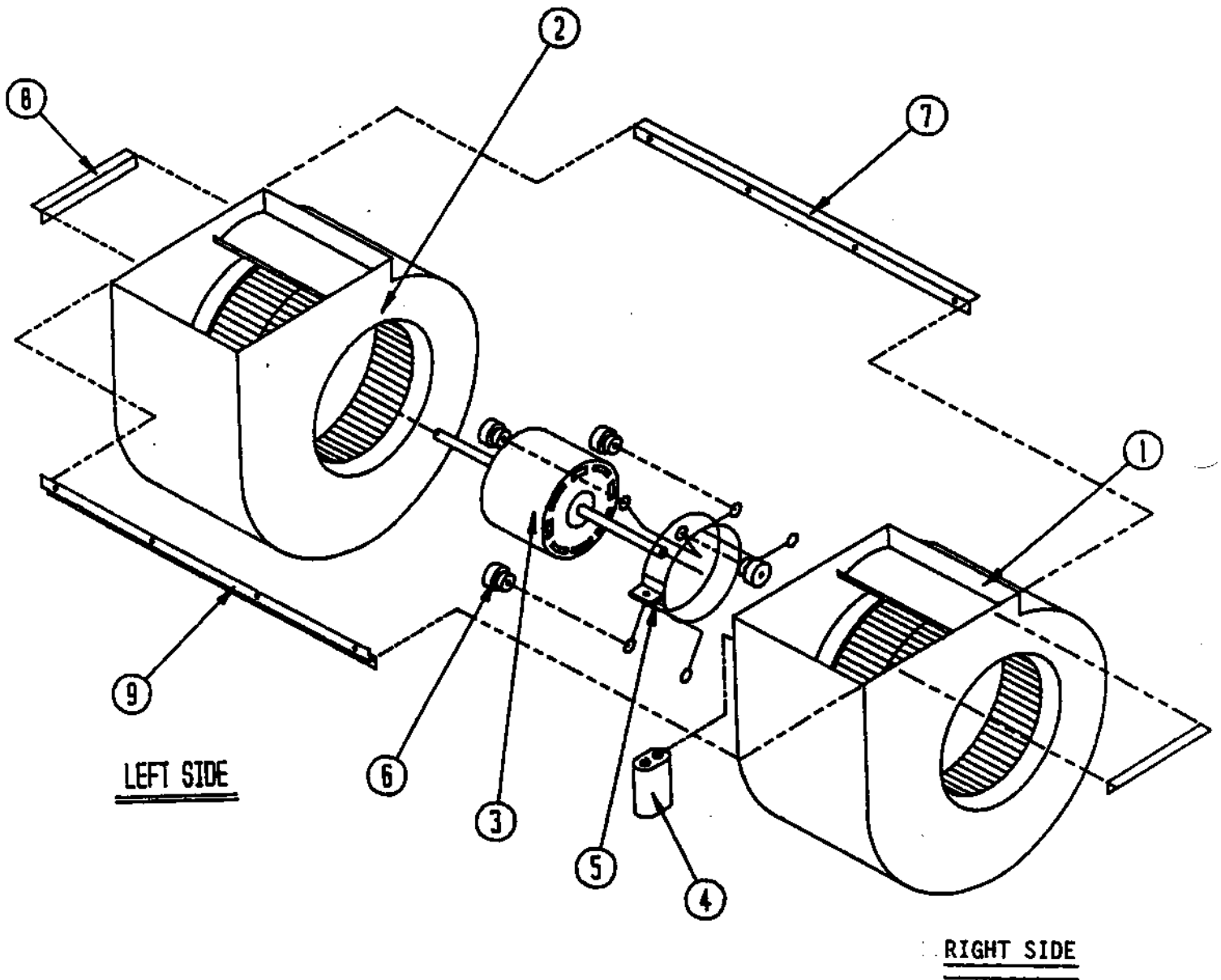

Date: 7-11-89
Supersedes:

BLOWER ASSEMBLY

Dwg. No.	Part No.	Description	9 0 0 0 0 3 9	9 0 0 0 0 7 0
1	5152-051	Housing, Wheel and Cutoff (CW)	X	X
2	5152-052	Housing, Wheel and Cutoff	X	X
3	8105-029	Blower Motor (230/208)	X	
3	8105-033	Blower Motor (460)		X
4	8552-002	Capacitor	X	X
5	8200-031	Motor Mount	X	X
6	5451-011	Grommets	6	6
7	104-505	Back Brace	X	X
8	104-001	Side Angle	2	2
9	102-300	Front Brace	X	X

Date: 7-11-89
Supersedes: