

REPLACEMENT PARTS MANUAL

WALL MOUNTED PACKAGE AIR CONDITIONER MODEL 20WA4

Manual 2110-401

Revision C

Date 2-15-91

Supersedes 6-20-90

* GENERAL NOTES *

*Revised and/or additional pages may be issued from time to time.
*A complete and current manual consists of pages dated as shown in the following index.

** INDEX **

<u>Page Description</u>	<u>Page</u>	<u>Date</u>	<u>Supersedes</u>
Cabinet Components--Exploded View	1	7-11-89	
" " --Usage List	2	2-15-91	1-25-90
Functional Components--Exploded View	3	7-11-89	
" " --Usage List	4	6-20-90	7-11-89
Control Panel--Layout View	5	7-11-89	
" " --Usage List	6	6-20-90	7-11-89
Blower Assembly--Exploded View	7	2-15-91	7-11-89
" " --Usage List	8	2-15-91	7-11-89

*** IMPORTANT ***

Contact the installing and/or local Bard distributor for all parts requirements. Make sure you have the complete model and serial number available from the unit rating plate.

BARD MANUFACTURING COMPANY

BRYAN, OHIO 43506

CABINET COMPONENTS

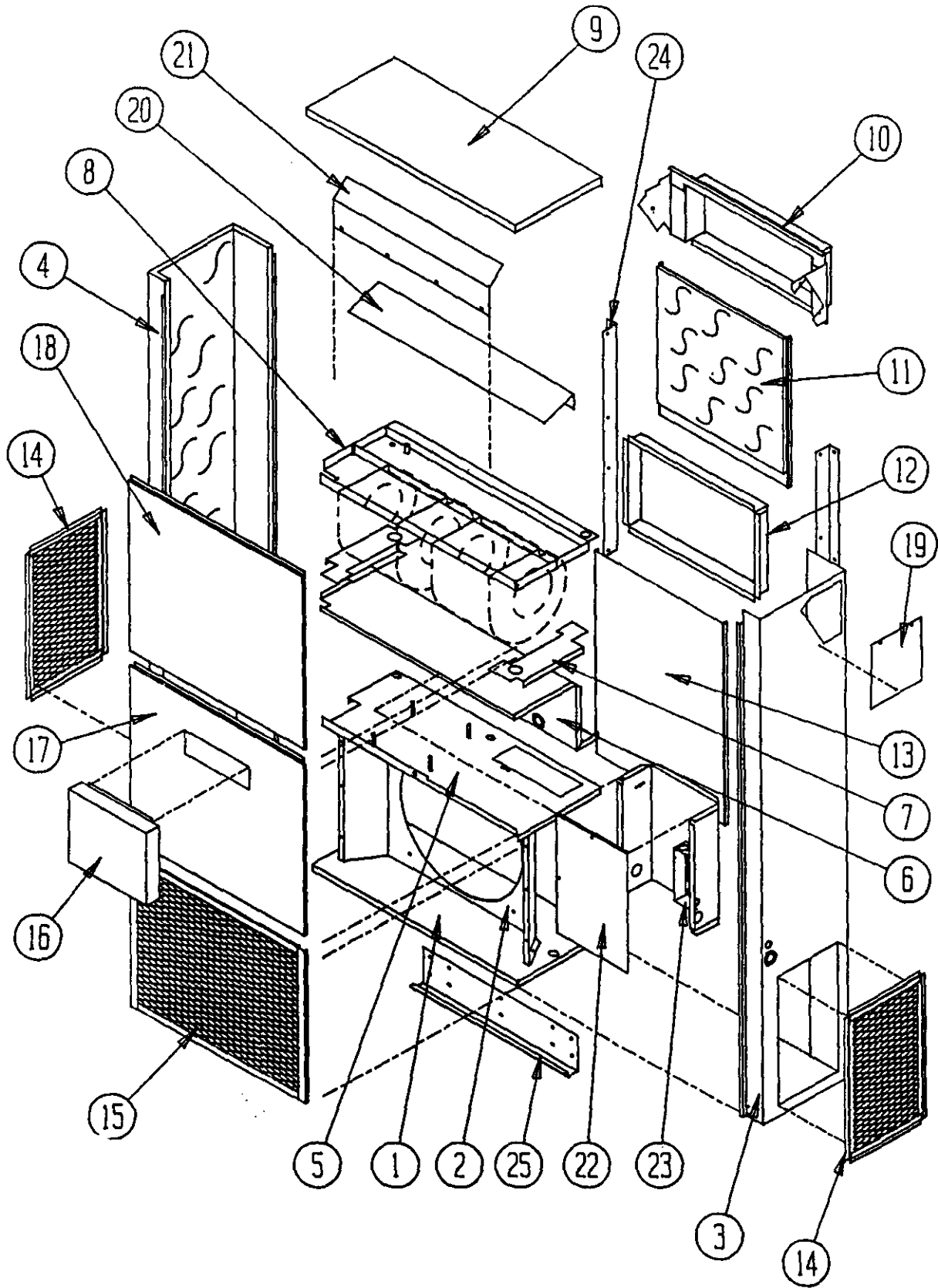

Date: 7-11-89
Supersedes:

CABINET COMPONENTS

Item No.	Part No.	Description	U S A G E
1	126-001	Lower Base	X
2	124-001	Fan Shroud	X
3	501-162	Right Side Assembly	X
4	501-163	Left Side Assembly	X
5	127-103	Compressor Base	X
6	520-096	Compressor Partition	X
7	130-001	Filter Support	X
8	121-089	Water Pan Assembly	X
9	506-094	Top	X
10	111-028	Supply Air Frame	X
11	508-054	Upper Back	X
12	111-029	Inlet Air Frame	X
13	108-055	Lower Back	X
14	119-002	Side Condenser Grille	X
15	119-001	Front Condenser Grille	X
16	962001	Fresh Air Damper	X
17	552-106	Service Door	X
18	514-045	Upper Front	X
19	542-001	Side Cover Plate	X
20	136-112	Evaporator Bottom Support Fill	X
21	134-004	Air Baffle	X
22	Control Panel Cvr	See Control Panel Assembly Drawing and Parts List	X X
23	Control Panel Asy	See Control Panel Assembly Drawing and Parts List	X X
24	112-002	Side Mounting Bracket	X
25	112-001	Bottom Support Bracket	X

Date: 2-15-91
Supersedes: 1-25-90

FUNCTIONAL COMPONENTS

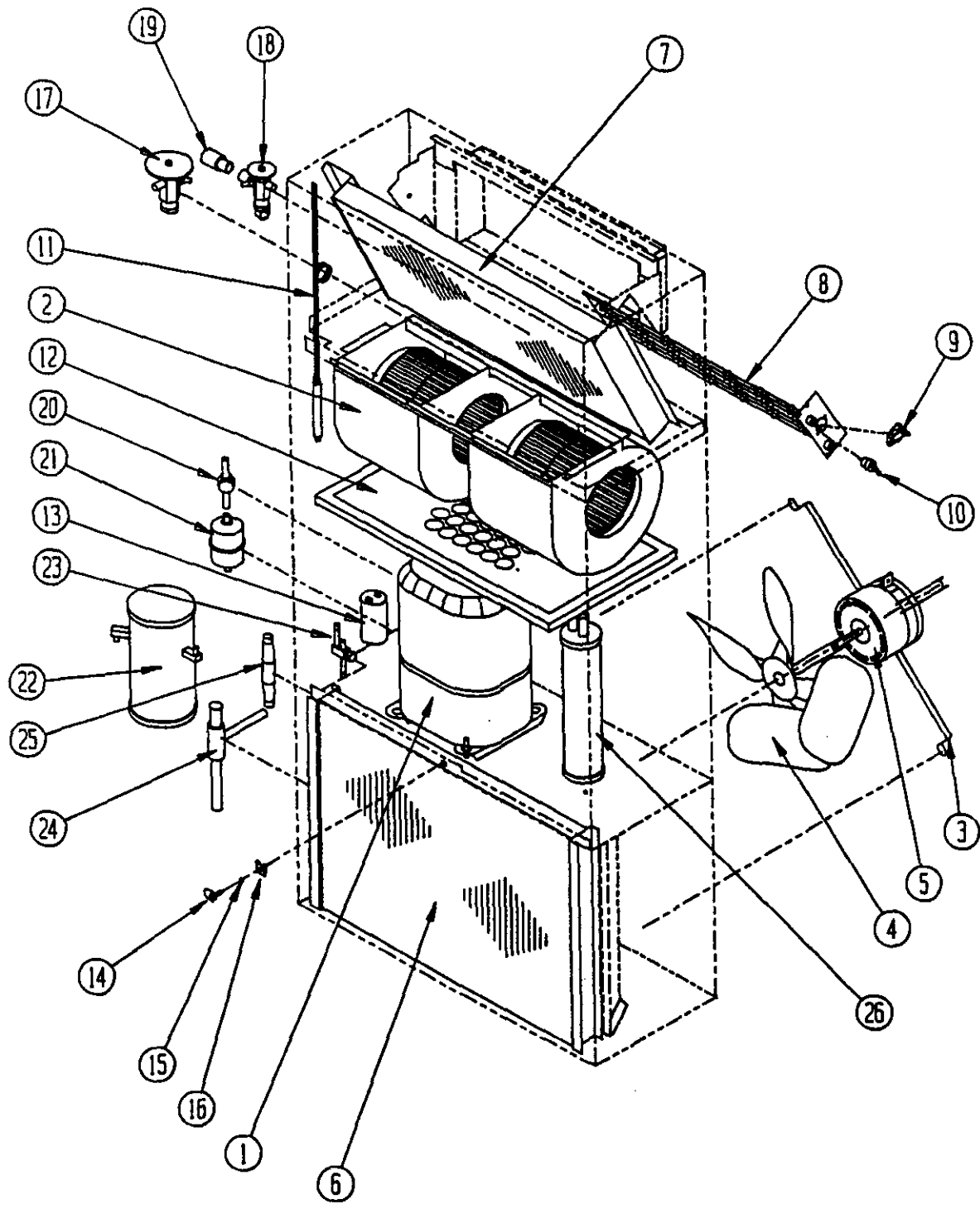

Date: 7-11-89
Supersedes:

FUNCTIONAL COMPONENTS

Dwg. No.	Part No.	Description	2 O W A 4 A O O N	2 O W A 4 A 0 5 N	2 O W A 4 A 0 8 N	2 O W A 4 A 1 0 N	2 O W A 4 A 0 0 C	2 O W A 4 A 0 5 C	2 O W A 4 A 0 8 C	2 O W A 4 A 1 0 C
1	8000-102	Compressor H23B173ABCA	X	X	X	X	X	X	X	X
2	900-038	Blower Assenbly (Complete)	X	X	X	X	X	X	X	X
3	8200-023	Fan Motor Mount	X	X	X	X	X	X	X	X
4	5151-033	Fan Blade F10H8.7	X	X	X	X	X	X	X	X
5	8103-016	Condenser Motor	X	X	X	X	X	X	X	X
6	5051-036	Condenser Coil	X	X	X	X	X	X	X	X
7	5060-048	Evaporator Coil	X	X	X	X	X	X	X	X
8	8604-089	Heat Strip 5KW		X			X			
8	8604-090	Heat Strip 8KW			X				X	
8	8604-091	Heat Strip 10KW				X				X
9	8402-048	Limit Switch 160 Degree		X	X	X		X	X	X
10	8402-030	Thermal Cutoff		1	2	2		1	2	2
11	800-0084	Capillary Assenbly	X	X	X	X	X	X	X	X
12	7004-006	Filter 14x25	X	X	X	X	X	X	X	X
13	8552-027	Capacitor 25/370	X	X	X	X	X	X	X	X
14	1171-019	1/4 Turn Fastener	X	X	X	X	X	X	X	X
15	1171-021	Retainer Clip	X	X	X	X	X	X	X	X
16	1171-020	Fastener Receptacle	X	X	X	X	X	X	X	X

Date: 6-20-90
Supersedes: 7-11-89

CONTROL PANEL

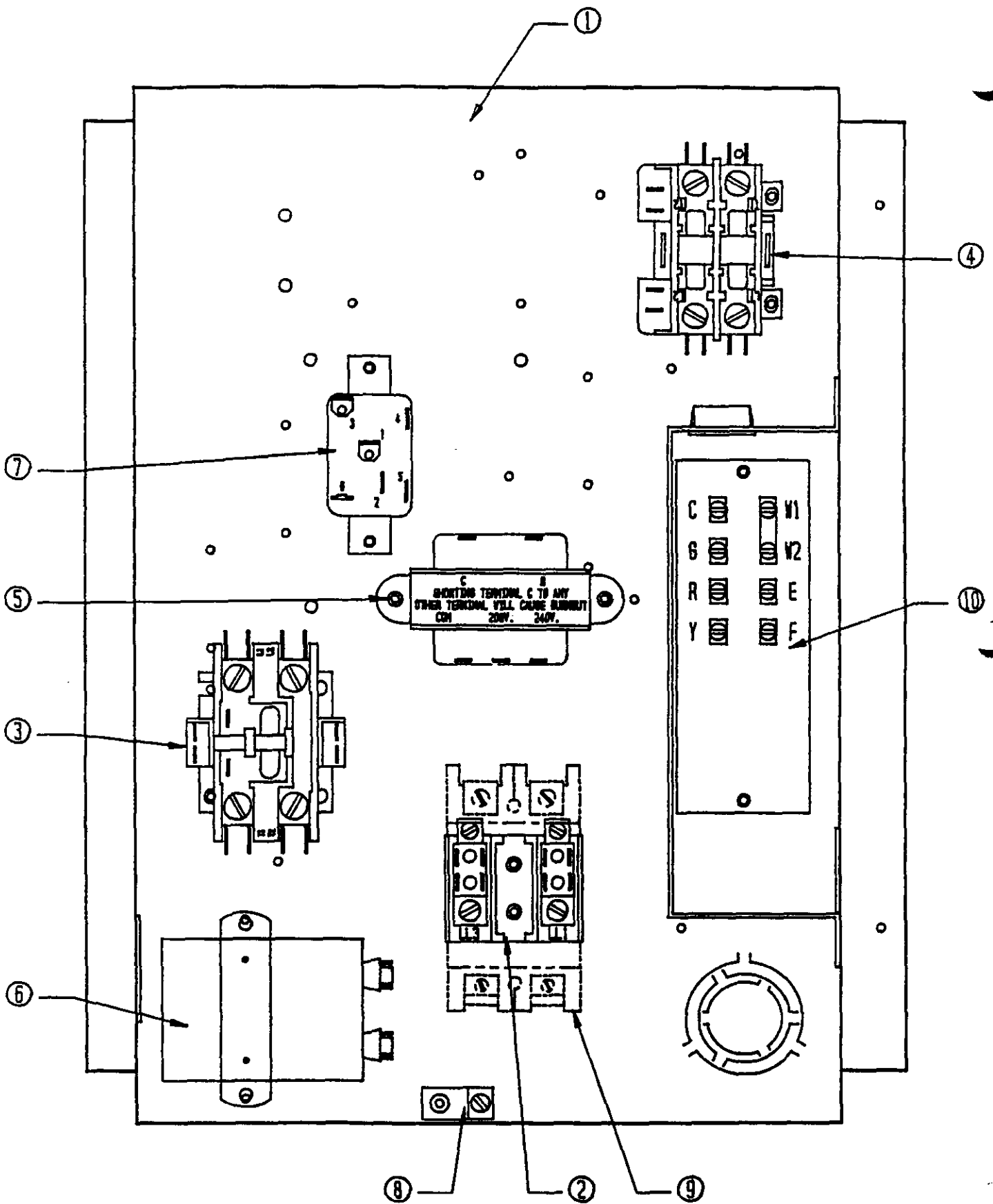

Date: 7-11-89
Supersedes:

CONTROL PANEL

Dwg. No.	Part No.	Description	2 O W A 4 A O O N	2 O W A 4 A O 5 N	2 O W A 4 A O 8 N	2 O W A 4 A O 0 N	2 O W A 4 A O 0 C	2 O W A 4 A O 5 C	2 O W A 4 A O 8 C	2 O W A 4 A O 0 C
	4007-110	Wiring Diagram	X							
	4007-120	Wiring Diagram		X						
	4007-130	Wiring Diagram			X	X				
	4007-111	Wiring Diagram					X			
	4007-121	Wiring Diagram						X		
	4007-131	Wiring Diagram							X	X
1	902-0249	Complete Control Panel Assembly	X							
1	902-0252	Complete Control Panel Assembly		X						
1	902-0256	Complete Control Panel Assembly			X	X				
1	902-0251	Complete Control Panel Assembly					X			
1	902-0254	Complete Control Panel Assembly						X		
1	902-0257	Complete Control Panel Assembly							X	
1	902-0258	Complete Control Panel Assembly								X
2	8607-013	Terminal Block 230V		X	X	X				
3	8401-007	Contacto--Comp. 25A	X	X	X	X	X	X	X	X
4	8401-006	Contacto--Heater 2P18		1	1	1		1	1	1
5	8407-034	Transformer 40VA	X	X	X	X	X	X	X	X
6	8552-002	Capacitor 5/370V	X	X	X	X	X	X	X	X
7	8201-009	Relay--Blower	X	X	X	X	X	X	X	X
8	8611-006	Ground Lug	X	X	X	X	X	X	X	X
9	8615-010	Circuit Breaker							X	
9	8615-012	Circuit Breaker					X			
9	8615-013	Circuit Breaker						X		
9	8615-016	Circuit Breaker								X
10	8607-018	Terminal Board 24V	X	X	X	X	X	X	X	X
	132-001	Control Panel Cover	X	X	X	X				
	132-068	Control Panel Cover					X	X	X	X

Date: 6-20-90
Supersedes: 7-11-89

BLOWER ASSEMBLY

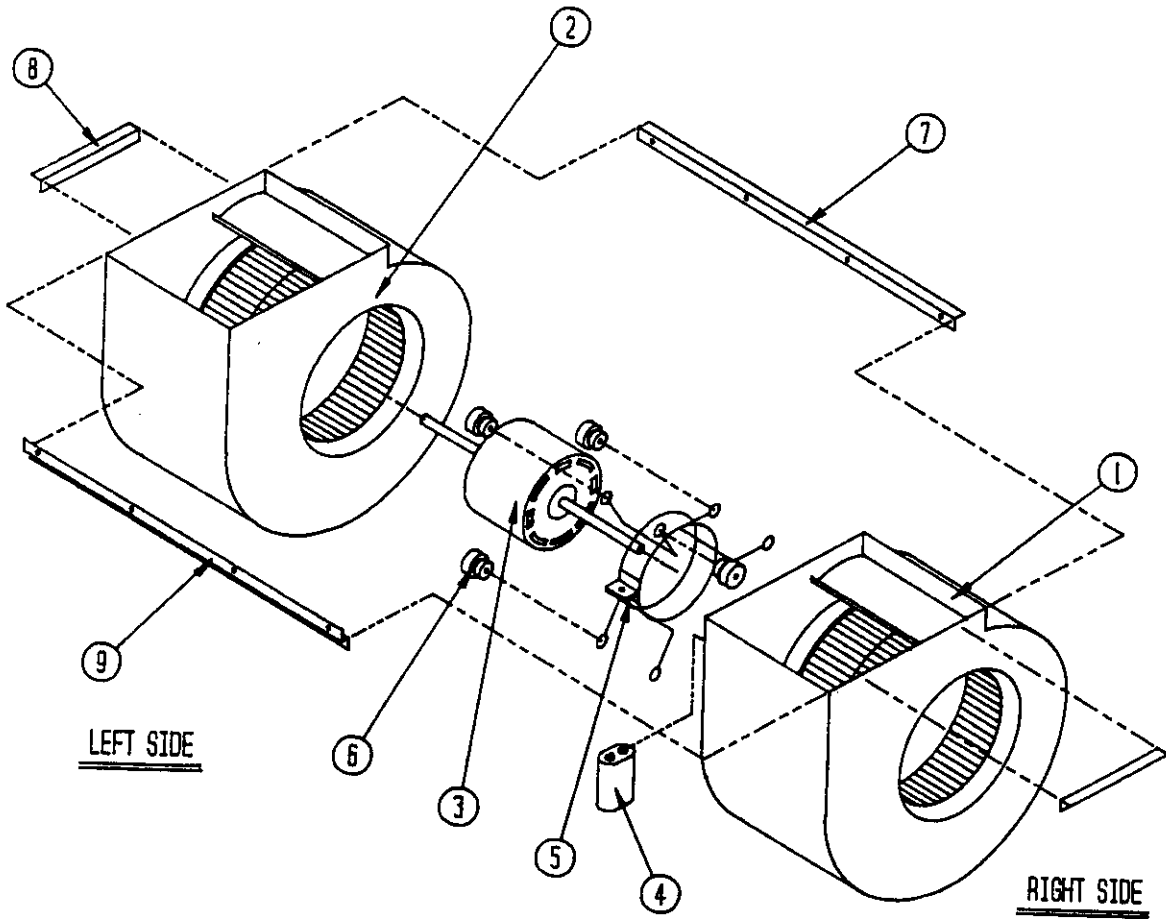

Date: 2-15-91
Supersedes: 7-11-89

BLOWER ASSEMBLY

Dwg. No.	Part No.	Description	900-038
1	5152-051	Blower Housing And Wheel Assembly	X
2	5152-052	Blower Housing And Wheel Assembly	X
3	8102-009	Blower Motor	X
4	8552-004	Capacitor 7.5/370V	X
5	8200-031	Blower Motor Mount	X
6	5451-011	Grommet	X
7	104-505	Angle Back Brace	X
8	104-001	Angle	X
9	102-300	Offset	X

Date: 2-15-91
 Supersedes: 7-11-89

