Replacement Parts Manual

Package Heat Pump

Models: **PH1224**
PH1230
PH1236

General Notes

- Revised and/or additional pages may be issued from time to time.
- A complete and current manual consists of pages shown in the following contents section.

Important

- Contact the installing and/or local Bard distributor for all parts requirements. Make sure you have the complete model and serial number available from the unit rating plates.

Contents

Description	Page
Cabinet Components	
♦ Exploded View	1
♦ Usage List	2
Functional Components	
♦ Exploded View	3
♦ Usage List	4
Control Panel	
♦ Exploded View	5
♦ Usage List	6
♦ Exploded View	7
♦ Usage List	8



BAR D MANUFACTURING COMPANY
Bryan, Ohio 43506

Since 1914...Moving, ahead just as planned.

Manual: 2110-260
Rev:
Date: 08-21-98

CABINET COMPONENTS

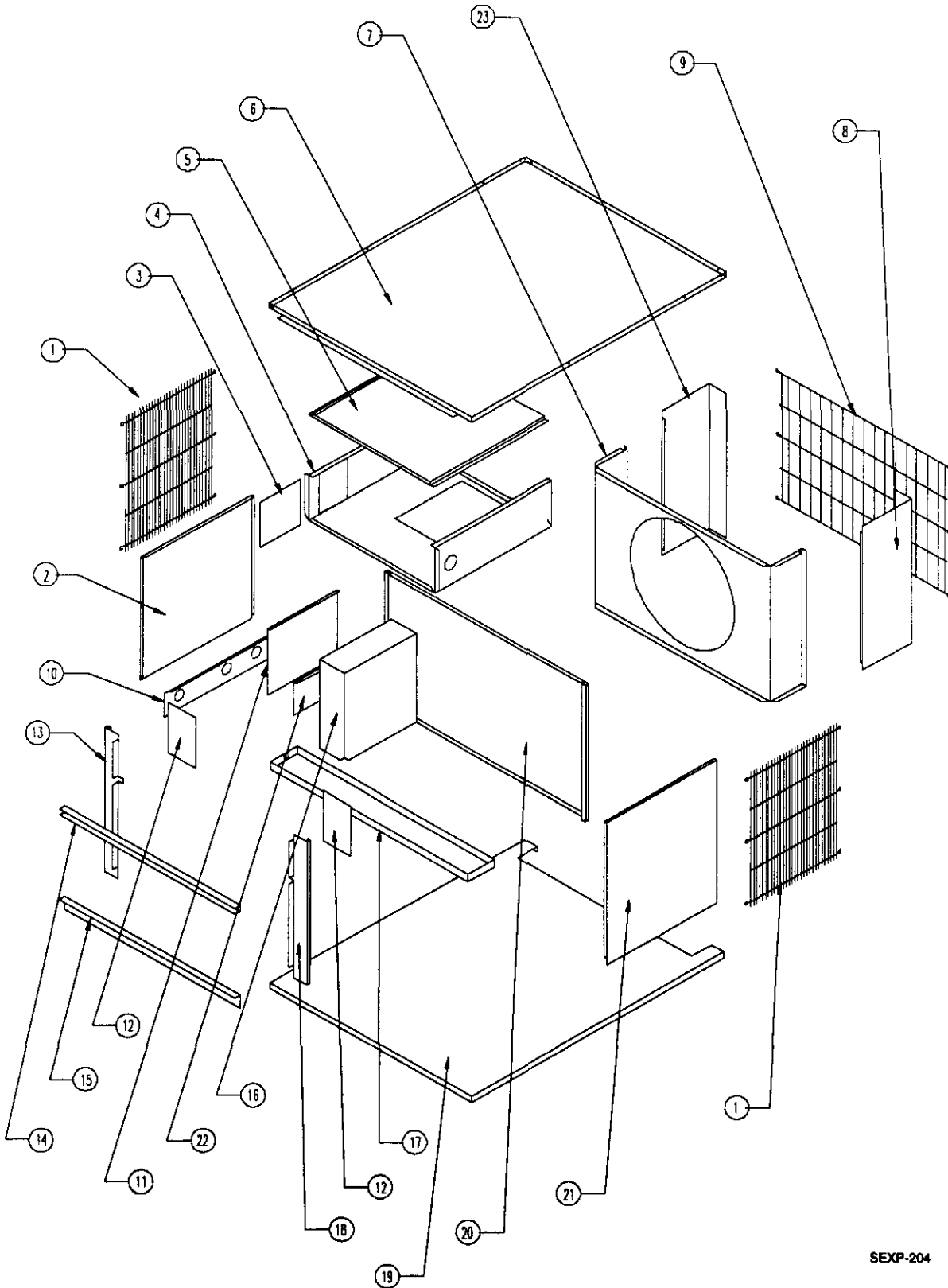

SEXP-204

CABINET COMPONENTS

Drawing No.	Part No.	Description	PH1224	PH1230	PH1236
1	7051-015	Inlet Grille	2	2	2
2	501-133-X	Left Side	X	X	X
3	142-017	Cover Plate – OKW	X	X	X
4	520-330	Blower Partition	X	X	X
5	134-017	Heat Strip	X	X	X
6	507-168-X	Top	X	X	X
7	125-012-X	Fan Shroud	X	X	X
8	149-085-X	Right Rear Corner	X	X	X
9	7051-001	Condenser Grille	X	X	X
10	557-028-X	Entrance Panel	X	X	X
11	133-035-X	Control Panel Cover	X	X	X
12	136-312	Blower Fill Plates	2	2	2
13	549-082-X	Left Front Cover	X	X	X
14	165-552-X	Plenum Channel	X	X	X
15	105-521-X	Plenum Angle	X	X	X
16	Control Panel Assembly	See Control Panel Drawing & Parts List	X	X	X
17	123-088-X	Drain Pan	X	X	X
18	549-081-X	Right Front Corner	X	X	X
19	527-255	Base	X	X	X
20	521-283-X	Compressor Partition	X	X	X
21	501-132-X	Right Side	X	X	X
22	142-016	Entrance Cover	X	X	X
23	149-086-X	Left Rear Corner	X	X	X

FUNCTIONAL COMPONENTS

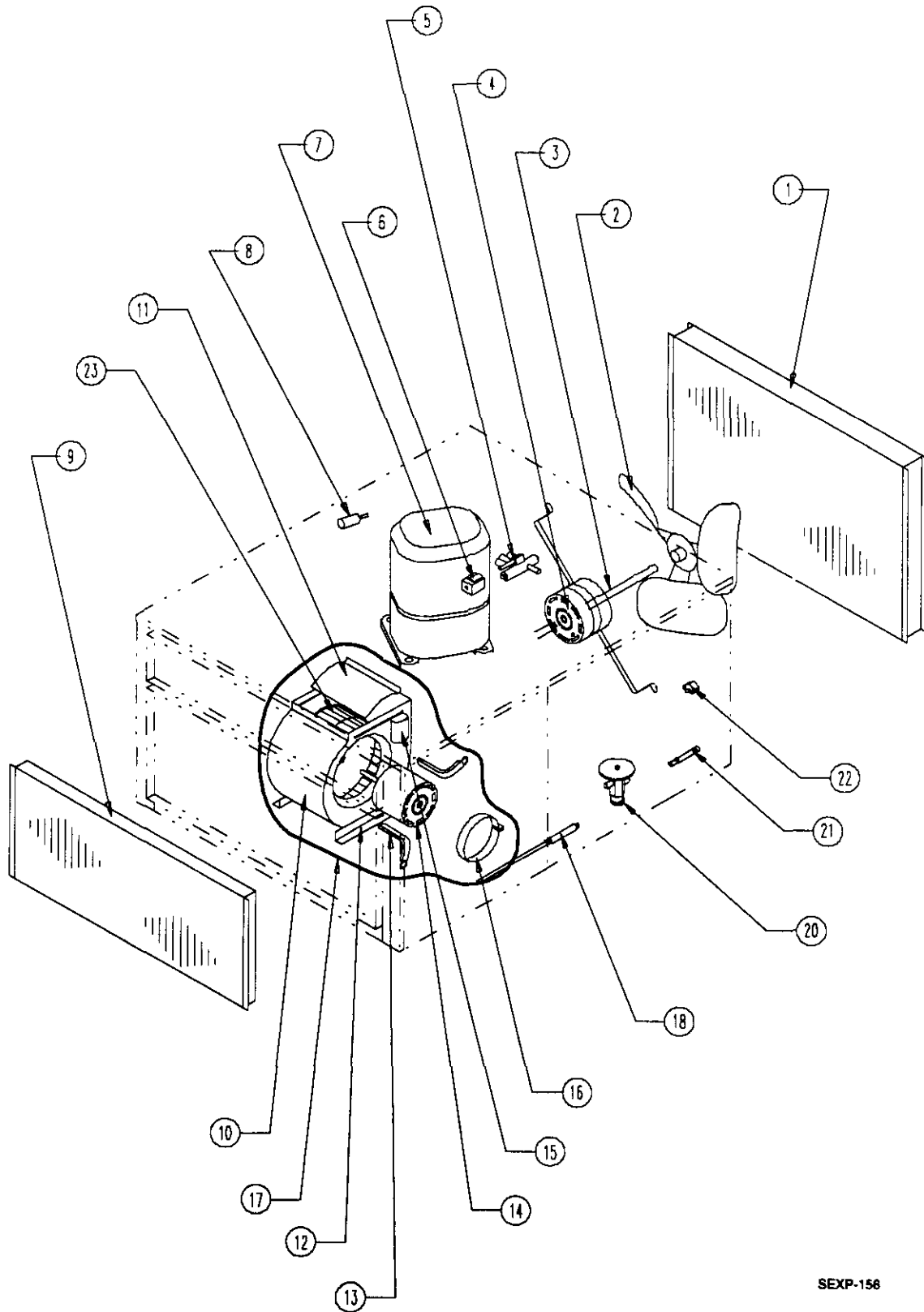

SEXP-156

FUNCTIONAL COMPONENTS

Drawing No.	Part No.	Description	PH1224	PH1230	PH1236	PH1236-B
1	5051-106	Condenser Coil	X	X		
1	5051-108	Condenser Coil			X	X
2	5151-034	Fan Blade	X			
2	5151-004	Fan Blade		X	X	X
3	8200-001	Motor Mount	X	X	X	X
4	8103-016	Motor	X			
4	8103-019	Motor		X	X	X
5	5650-020	Reversing Valve	X	X	X	X
6	5650-022	Reversing Valve Solenoid	X	X	X	X
7	8000-170	Compressor ZR22K3-PFV-230	X			
7	8000-172	Compressor ZR28K3-PFV-230		X		
7	8000-175	Compressor ZR34K3-PFV-230			X	
7	8000-163	Compressor ZR34K3-TF5-230				X
8	8406-040	High Pressure Switch	X	X	X	X
9	5060-052	Evaporator Coil	X			
9	5060-100	Evaporator Coil		X	X	X
10	151-097	Blower Housing	X	X	X	X
11	144-130	Blower Diffuser	X	X	X	X
12	104-1043	Blower Angle	X	X	X	X
13	8000-034	Motor Mount Arm	3	3	3	3
14	8106-035-0017	Motor		X		
14	8105-045-0016	Motor	X			
14	8106-035-0021	Motor			X	X
16	8200-033	Motor Mount Band	X	X	X	X
17	900-239-001	Complete Blower Assembly	X			
17	900-240-001	Complete Blower Assembly		X		
17	900-240-002	Complete Blower Assembly			X	X
18	5625-025	Cooling Flow Control Assembly	X			
18	5625-026	Cooling Flow Control Assembly		X		
18	5625-027	Cooling Flow Control Assembly			X	X
20	5651-138	Expansion Valve	X	X		
20	5651-102	Expansion Valve			X	X
22	910-1257	Defrost Sensor	X	X	X	X
23	5152-049	Blower Wheel	X	X	X	X

CONTROL PANEL

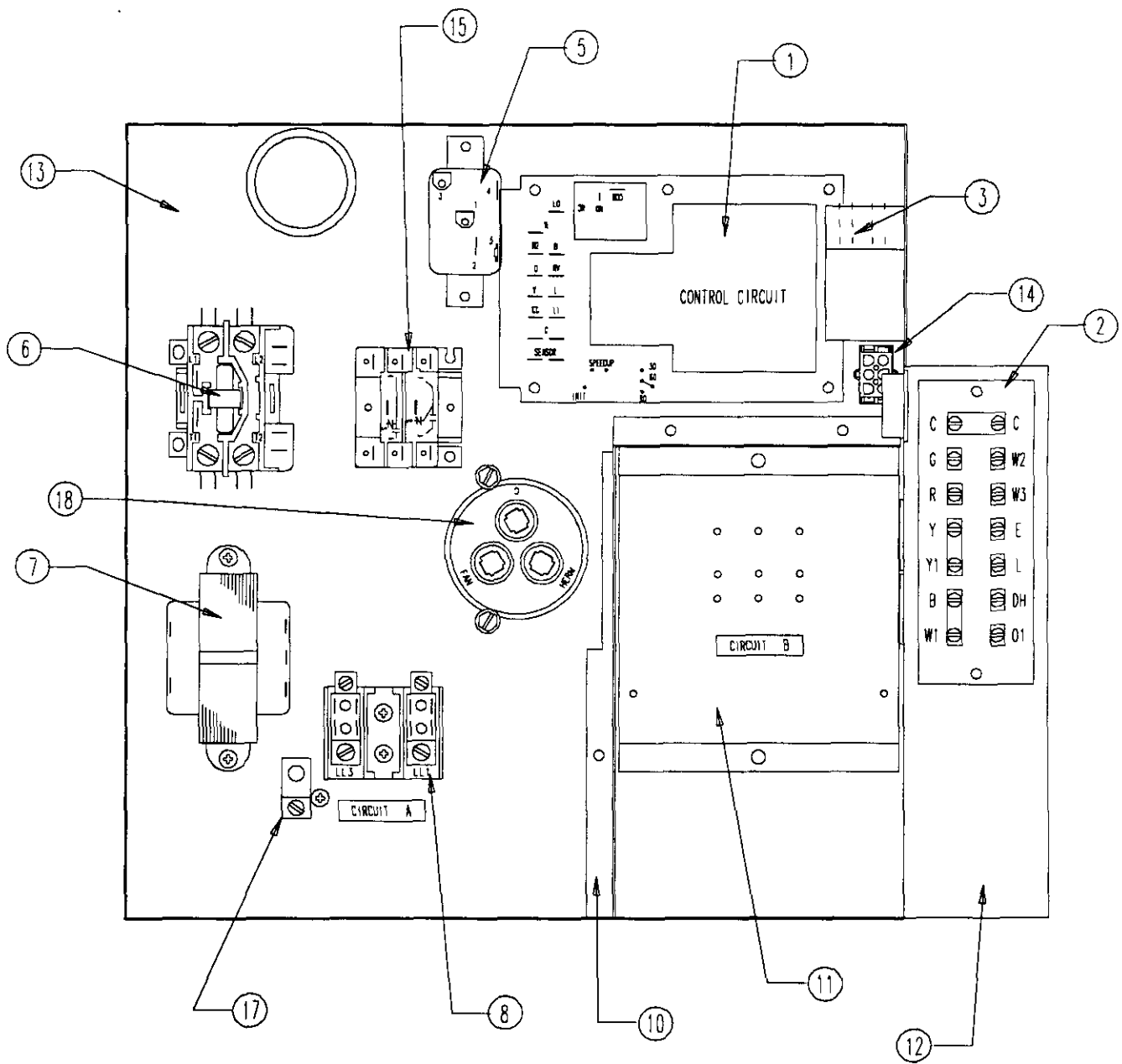

SEXP-303

CONTROL PANEL

Drawing			PH1224	PH1230	PH1236
No.	Part No.	Description			
1	8201-069	Heat Pump Control	X	X	X
2	8607-019	Terminal Strip	X	X	X
3	8201-074	Blower Interlock Relay	X	X	X
5	8201-008	Defrost Heat Relay	X	X	X
6	8401-007	Contactor	X	X	X
7	8407-035	Transformer	X	X	X
8	8607-013	Terminal Block	X	X	X
10	116X076	Control Panel Partition	X	X	X
11	134-095	Terminal Block Shield	X	X	X
12	116-148	Low Voltage Box	X	X	X
13	516Y141	Control Panel	X	X	X
14	3000-976	Wire Assembly	X	X	
14	3000-974	Wire Assembly			X
15	8201-013	Emergency Heat Relay			X
17	8611-006	Ground Terminal	X	X	X
18	8552-050	Capacitor 40/5 – 370	X		
18	8552-052	Capacitor 45/5 – 370		X	
18	8552-056	Capacitor 50/10 – 440			X
NS	4098-123	Wiring Diagram	X		
NS	4098-124	Wiring Diagram		X	X

NS Not Shown

CONTROL PANEL

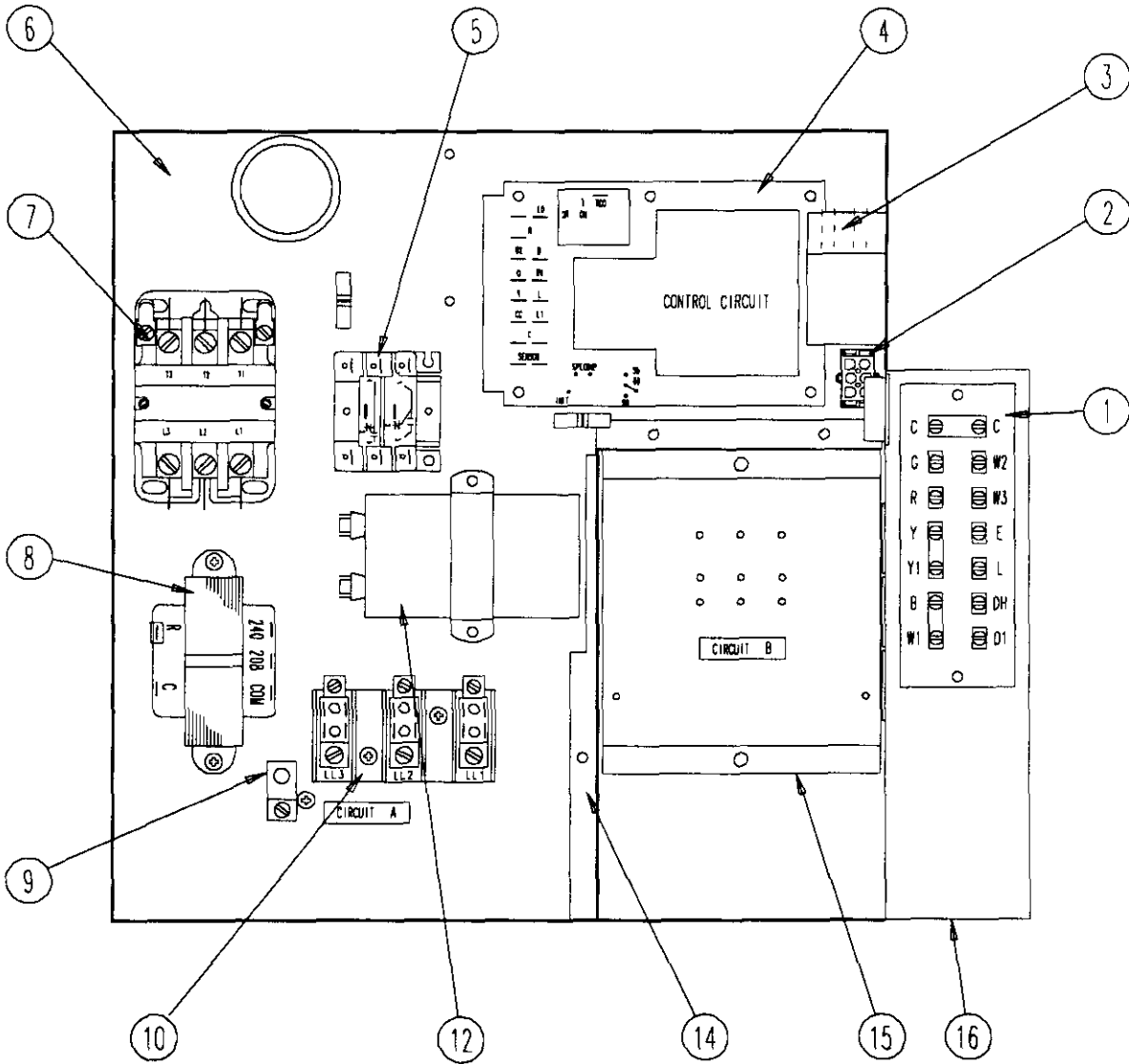

SEXP-304

CONTROL PANEL

Drawing No.	Part No.	Description	PH1236-B
1	8607-019	Terminal Strip	X
2	3000-1100	Wire Assembly	X
3	8201-074	Blower Interlock Relay	X
4	8201-069	Heat Control Pump	X
5	8201-013	Changeover Relay	X
6	516-147	Control Panel	X
7	8401-002	Contactors	X
8	8407-035	Transformer	X
9	8611-006	Ground Terminal	X
10	8607-014	Terminal Block	X
12	8552-002	Capacitor 5 – 370	X
14	116-149	Control Panel Partition	X
15	116-150	Terminal Block Support	X
16	116-148	Low Voltage Box	X
NS	4098-211	Wiring Diagram	X

NS Not Shown

