

# REPLACEMENT PARTS MANUAL

## PACKAGE AIR CONDITIONERS

MODELS:  
P1142A2, P1148A1, P1148A1-B, P1148A1-C,  
P1060A1, P1060A1-B, P1060A1-C

Manual 2110-210

Revision A

Date 12-20-93

Supersedes 9-01-93

\*\*\*\*\*  
\* GENERAL NOTES \*  
\*\*\*\*\*

\*Revised and/or additional pages may be issued from time to time.  
\*A complete and current manual consists of pages dated as shown in the following index.

\*\*\*\*\*  
\*\* INDEX \*\*  
\*\*\*\*\*

<u>Page Description</u>	<u>Page</u>	<u>Date</u>	<u>Supersedes</u>
Cabinet Components--Exploded View	1	9-01-93	
" " --Usage List	2	9-01-93	
Functional Components--Exploded View	3	9-01-93	
" " --Usage List	4	9-01-93	
Control Panel--Layout	5	9-01-93	
" " --Usage List	6	12-20-93	9-01-93

\*\*\*\*\*  
\*\*\* IMPORTANT \*\*\*  
\*\*\*\*\*

Contact the installing and/or local Bard distributor for all parts requirements. Make sure you have the complete model and serial number available from the unit rating plate.

BARD MANUFACTURING COMPANY

BRYAN, OHIO 43506

CABINET COMPONENTS

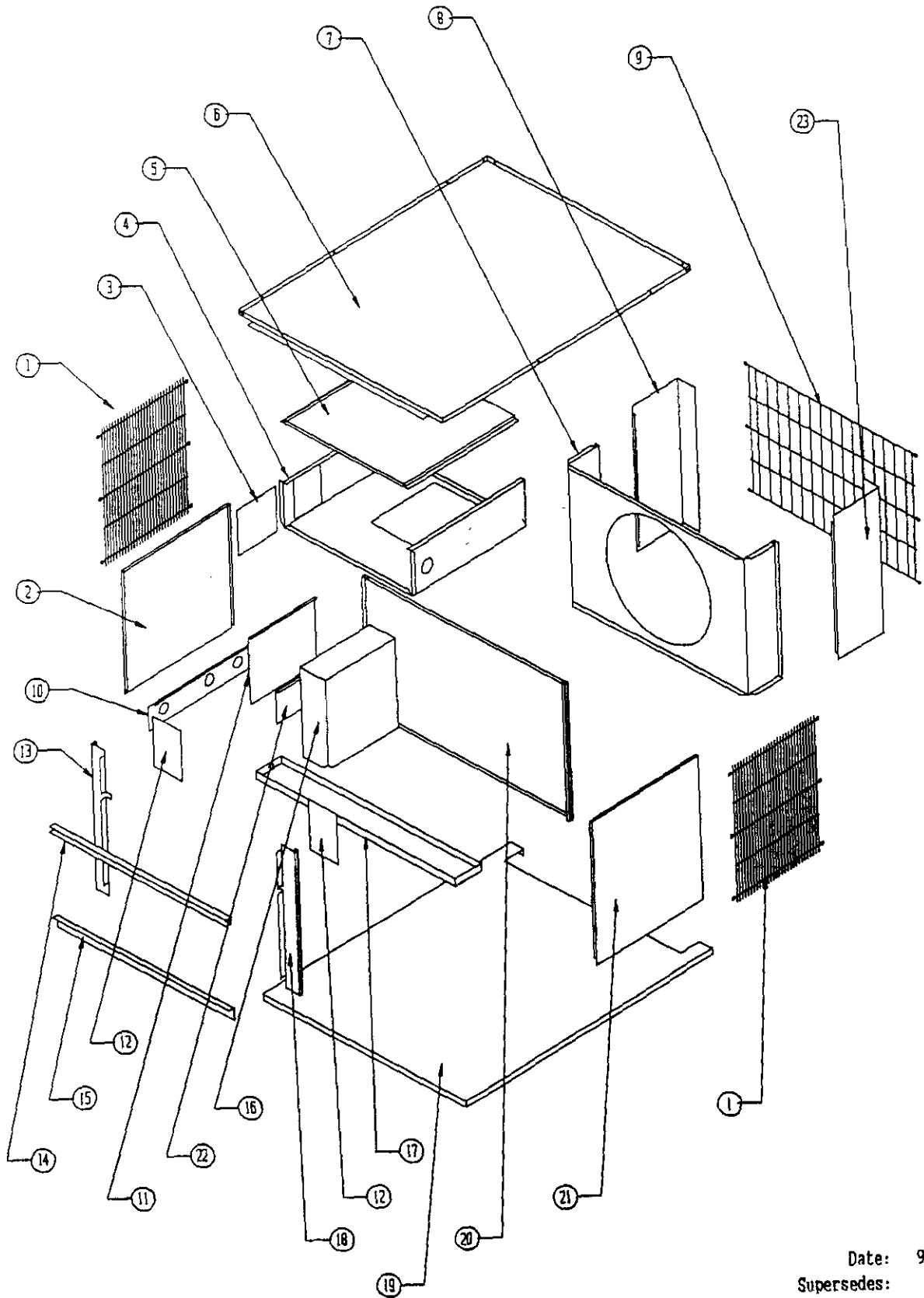

Date: 9-01-93  
Supersedes:

CABINET COMPONENTS

Item	Part No.	Description	U S A G E
1	7051-007	Inlet Grille	2
2	500-272	Left Side	X
3	142-045	Cover Plate--OKW	X
4	520-240	Blower Partition	X
5	134-134	Heat Strip Shield	X
6	506-146	Top	X
7	125-024	Fan Shroud	X
8	148-079	Left Rear Corner	X
9	7051-005	Condenser Grille	X
10	556-026	Entrance Panel	X
11	132-035	Control Panel Cover	X
12	136-246	Blower Fill Plates	2
13	548-077	Left Front Corner	X
14	164-502	Plenum Channel	X
15	104-525	Plenum Angle	X
16	Cntrl Pnl Assembly	See Control Panel Drawing and Parts List	X
17	122-084	Drain Pan	X
18	548-076	Right Front Corner	X
19	527-221	Base	X
20	520-239	Compressor Partition	X
21	500-271	Right Side	X
22	142-044	Entrance Cover	X
23	148-078	Right Rear Corner	X

Date: 9-01-93  
Supersedes:

FUNCTIONAL COMPONENTS

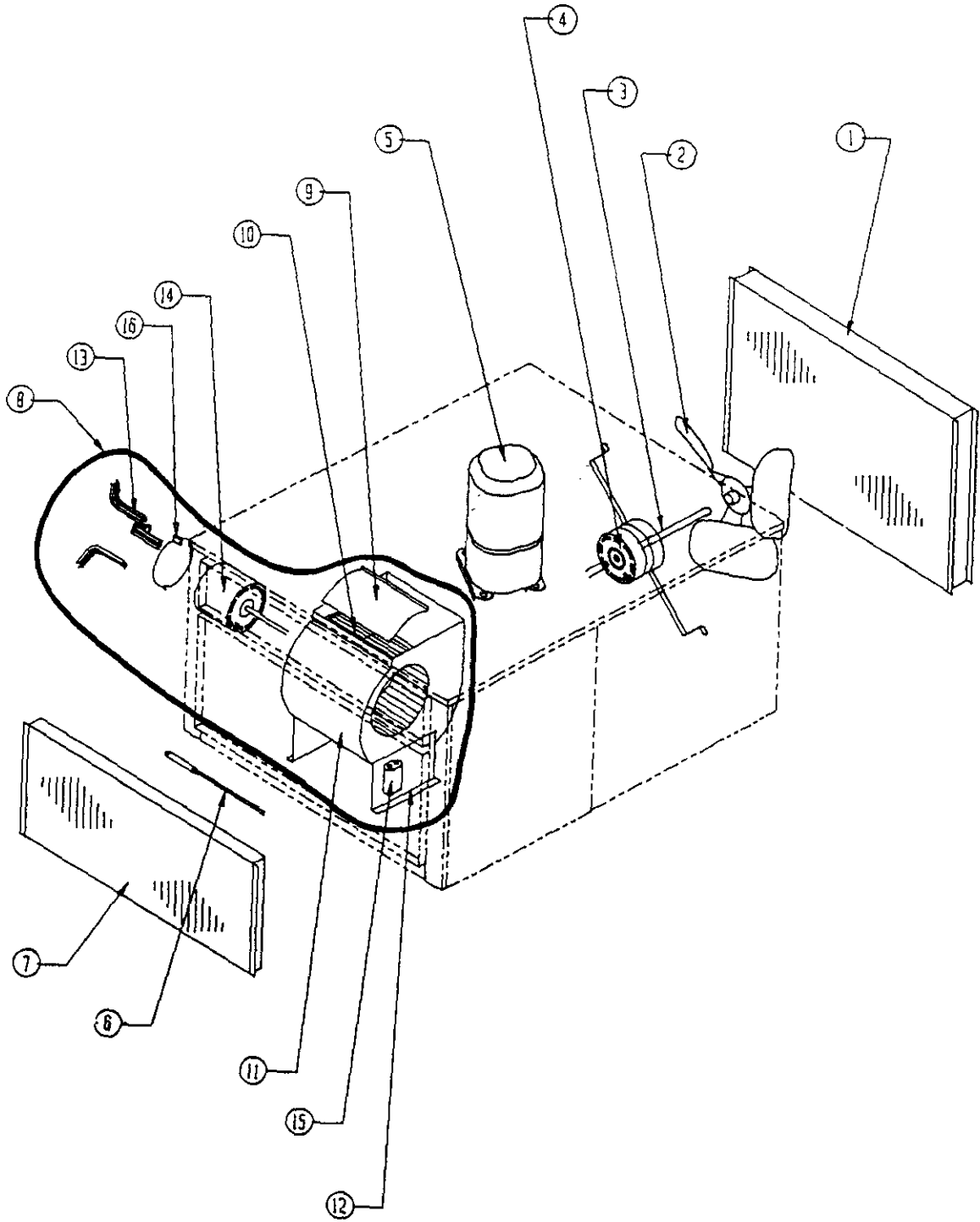

Date: 9-01-93  
Supersedes:

FUNCTIONAL COMPONENTS

Dwg. No.	Part No.	Description	P	P	P	P	P	P	P
			1	1	1	1	1	1	1
			4	4	4	6	6	6	4
			8	8	8	0	0	0	2
			A	A	A	A	A	A	A
			1	1	1	1	1	1	2
				-	-		-	-	
				B	C		B	C	
1	5051-083	Condenser Coil	X	X	X				
1	5051-074	Condenser Coil				X	X	X	
1	5051-078	Condenser Coil							X
2	5151-027	Fan Blade	X	X	X	X	X	X	X
3	8200-004	Motor Mount	X	X	X	X	X	X	X
4	8105-039	Motor	X	X		X	X		X
4	8105-030	Motor			X			X	
5	8000-153	Compressor				X			
5	8000-154	Compressor					X		
5	8000-155	Compressor						X	
5	8000-109	Compressor							X
5	8000-149	Compressor	X						
5	8000-156	Compressor		X					
5	8000-157	Compressor			X				
6	800-0215	Capillary Tube Assembly	X	X	X				
6	800-0216	Capillary Tube Assembly				X	X	X	
6	800-0222	Capillary Tube Assembly							X
7	5060-070	Evaporator Coil	X	X	X				X
7	5060-071	Evaporator Coil				X	X	X	
8	900-0190	Complete Blower Assembly	X	X		X	X		
8	900-0191	Complete Blower Assembly							X
8	900-0192	Complete Blower Assembly			X			X	
9	144-130	Diffuser	X	X	X	X	X	X	X
10	5152-049	Blower Wheel	X	X	X	X	X	X	
10	5152-071	Blower Wheel							X
11	151-097	Blower Housing	X	X	X	X	X	X	X
12	104-795	Blower Angles	X	X	X	X	X	X	X
13	8200-034	Motor Mount Arms	3	3	3	3	3	3	3
14	8106-031	Motor	X	X		X	X		X
14	8106-032	Motor			X			X	
15	8552-005	Capacitor	X	X	X	X	X	X	X
16	8200-033	Motor Mount Band	X	X	X	X	X	X	X

Date: 9-01-93  
Supersedes:

CONTROL PANEL

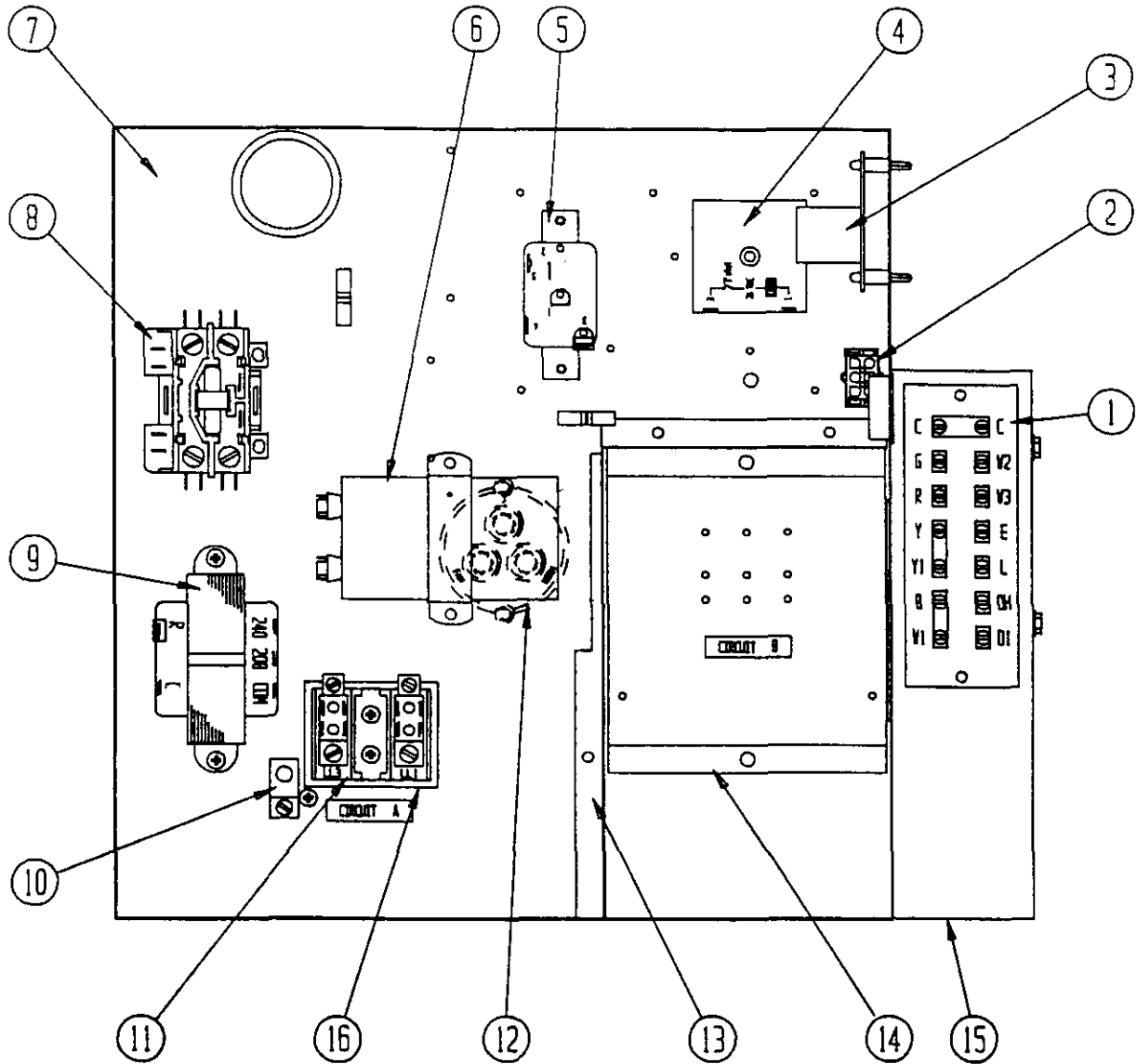

Date: 9-01-93  
Supersedes:

CONTROL PANEL

Dwg. No.	Part No.	Description	P	P	P	P	P	P	P
			1	1	1	1	1	1	1
			1	1	1	0	0	0	1
			4	4	4	6	6	6	4
			8	8	8	0	0	0	2
			A	A	A	A	A	A	A
			1	1	1	1	1	1	2
				-	-		-	-	
				B	C		B	C	
1	8607-018	Terminal Strip	x	x	x	x	x	x	x
2	3000-988	Wire Assembly	x	x	x	x	x	x	x
3	8201-056	Solid State Blower Control	x	x		x	x		x
3	8201-032	Blower Relay			x			x	
4	8201-050	Time Delay Relay	x	x	x	x	x	x	x
5	8201-034	Impedance Relay	x	x	x	x	x	x	x
6	8552-005	Capacitor 10-370		x	x		x	x	
7	516-147	Control Panel	x	x	x	x	x	x	x
8	8401-016	Contactor	x			x			
8	8401-002	Contactor		x	x		x	x	
8	8401-007	Contactor							x
9	8407-034	Transformer	x	x		x	x		x
9	8407-042	Transformer			x			x	
10	8611-006	Ground Terminal	x	x	x	x	x	x	x
11	8607-013	Terminal Block	x			x			x
11	8607-014	Terminal Block		x	x		x	x	
12	8552-059	Capacitor 60/10-370	x						
12	8552-058	Capacitor 80/10-370				x			
12	8552-057	Capacitor 35/10-440							x
13	116-149	Control Panel Partition	x	x	x	x	x	x	x
14	116-150	Terminal Block Support	x	x	x	x	x	x	x
15	116-148	Low Voltage Box	x	x	x	x	x	x	x
16	8607-015	Phenolic Insulator			x			x	
	4064-116	Wiring Diagram	x			x			
	4064-213	Wiring Diagram		x			x		
	4064-314	Wiring Diagram			x			x	
	4064-115	Wiring Diagram							x

Date: 12-20-93  
Supersedes: 9-28-89

