

# REPLACEMENT PARTS MANUAL

## PACKAGE AIR CONDITIONERS MODEL P1045A1

Manual 2110-204

Revision --

Date 9-28-89

Supersedes

\*\*\*\*\*  
\* GENERAL NOTES \*  
\*\*\*\*\*

\*Revised and/or additional pages may be issued from time to time.  
\*A complete and current manual consists of pages dated as shown in the following index.

\*\*\*\*\*  
\*\* INDEX \*\*  
\*\*\*\*\*

<u>Page Description</u>	<u>Page</u>	<u>Date</u>	<u>Supersedes</u>
Cabinet Components--Exploded View	1	9-28-89	
" " --Usage List	2	9-28-89	
Functional Components--Exploded View	3	9-28-89	
" " --Usage List	4	9-28-89	
Control Panel--Layout	5	9-28-89	
" " --Usage List	6	9-28-89	

\*\*\*\*\*  
\*\*\* IMPORTANT \*\*\*  
\*\*\*\*\*

Contact the installing and/or local Bard distributor for all parts requirements. Make sure you have the complete model and serial number available from the unit rating plate.

BARD MANUFACTURING COMPANY

BRYAN, OHIO 43506

CABINET COMPONENTS

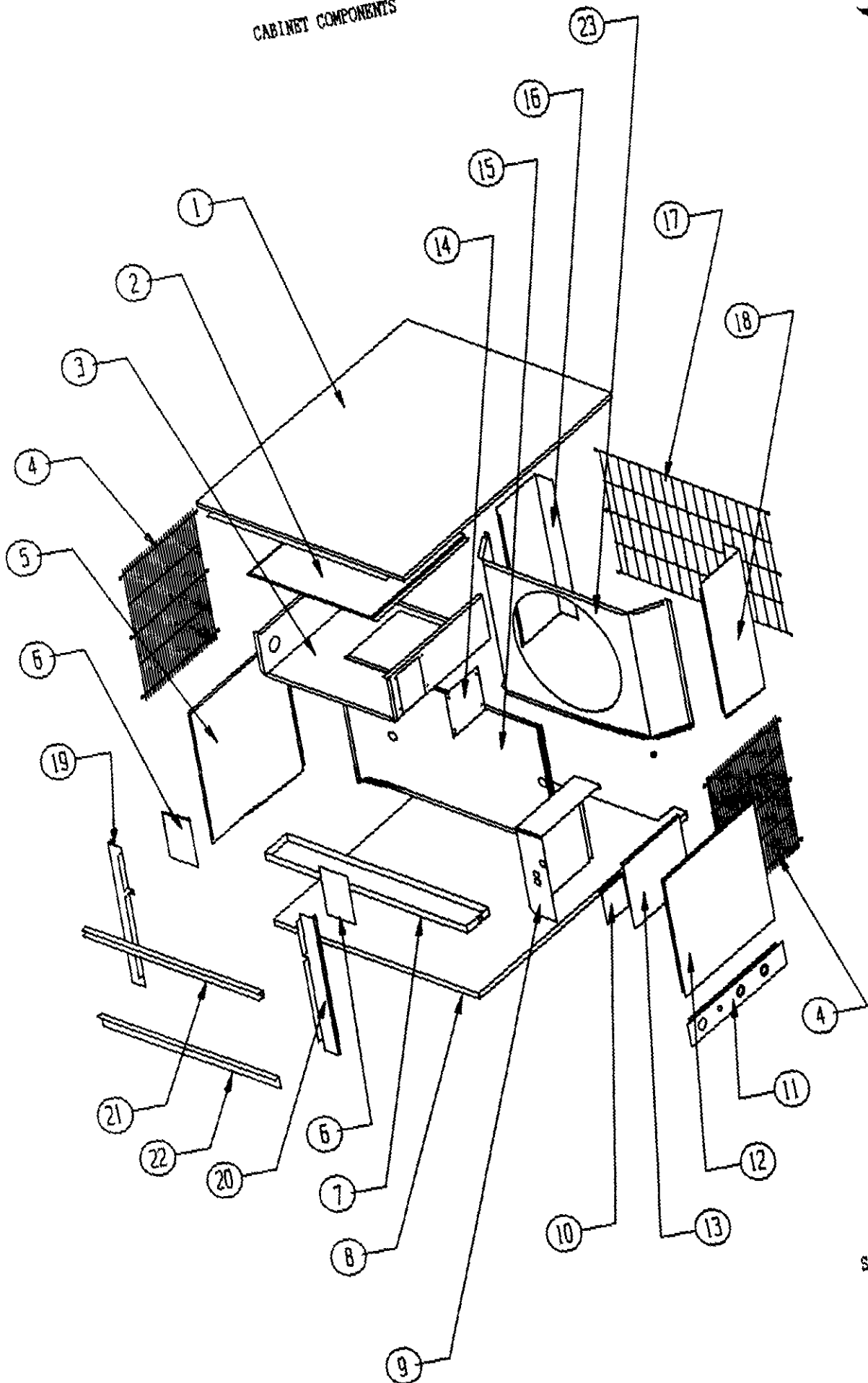

Date: 9-28-89  
Supersedes:  
2110-204  
Page 1

CABINET COMPONENTS

Item	Part No.	Description	U S A G E
1	506-012	Top	X
2	134-021	Heat Strip Shield	X
3	520-067	Blower Partition	X
4	7051-007	Side Grille	2
5	500-144	Left Side	X
6	136-011	Side Fills	2
7	123-048	Drain Pan	X
8	527-012	Base	X
9	Control Panel	See control panel drawing and parts list	X
10	142-016	Entrance Cover Plate	X
11	556-015	Entrance Panel	X
12	500-020	Right Side	X
13	132-035	Control Panel Cover	X
14	142-017	OKW Cover Plate	X
15	520-069	Compressor Partition	X
16	149-053	Left Rear Corner	X
17	7051-005	Condenser Grille	X
18	149-052	Right Rear Corner	X
19	549-050	Left Front Corner	X
20	549-016	Right Front Corner	X
21	164-502	Plenum Channel	X
22	104-525	Plenum Angle	X
23	124-010	Fan Shroud	X

Date: 9-28-89  
Supersedes:

FUNCTIONAL COMPONENTS

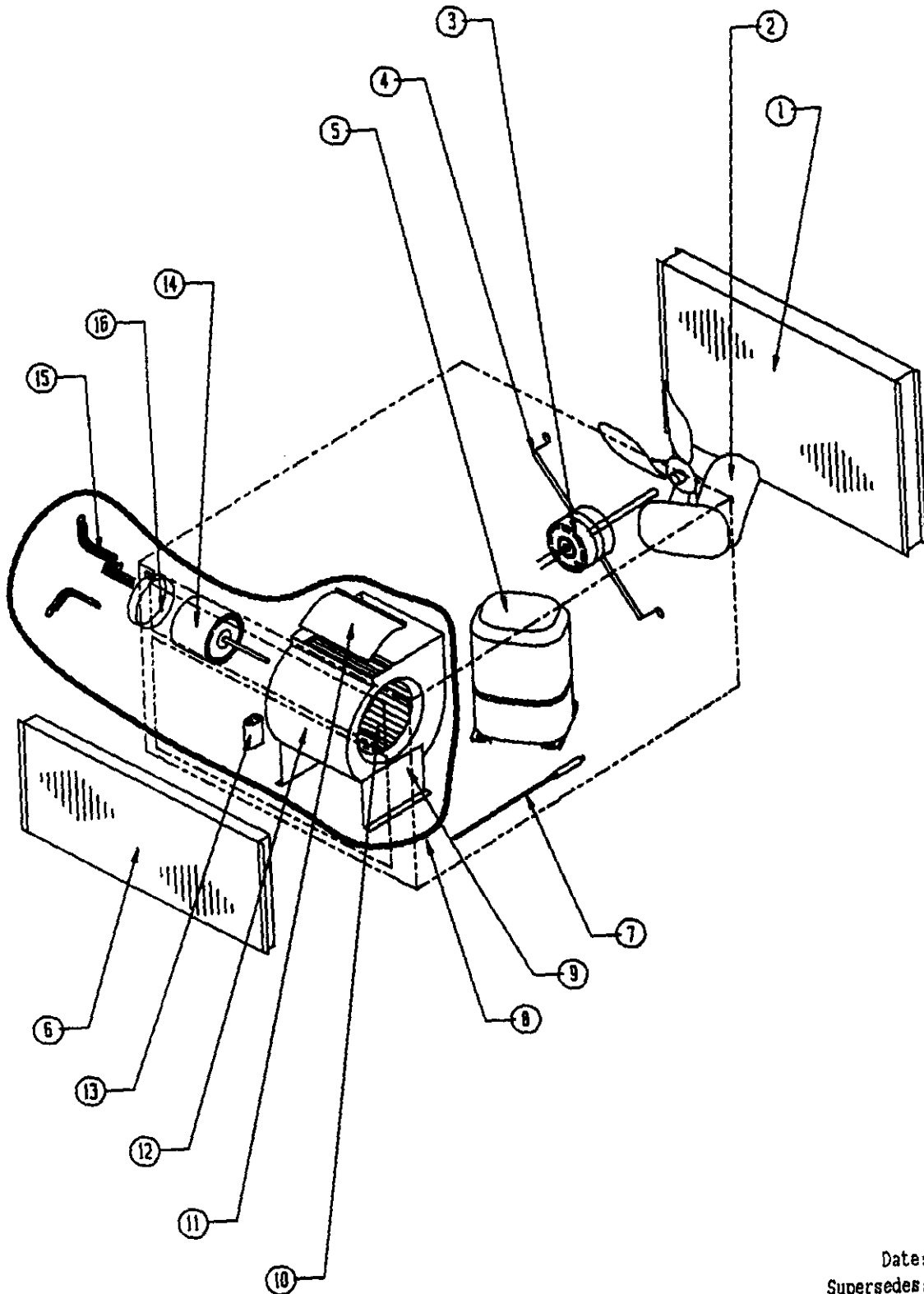

Date: 9-28-89  
Supersedes:

FUNCTIONAL COMPONENTS

Dwg. No.	Part No.	Description	P 1 0 4 5 A 1
1	5051-051	Condenser Coil	X
2	5151-029	Fan Blade	X
3	8105-035	Motor	X
4	8200-004	Fan Motor Mount	X
5	8000-058	Compressor	X
6	5060-051	Evaporator Coil	X
7	800-0091	Capillary Tube Assembly	X
8	900-139	Complete Blower Assembly	X
9	104-795	Blower Leg	2
10	5152-015	Blower Wheel	X
11	144-129	Blower Diffuser	X
12	151-082	Blower Housing	X
13	8552-005	Capacitor 10/370	X
14	8106-015	Motor	X
15	8200-034	Motor Mount Arm	3
16	8200-033	Motor Mount Band	X

Date: 9-28-89  
Supersedes:

CONTROL PANEL

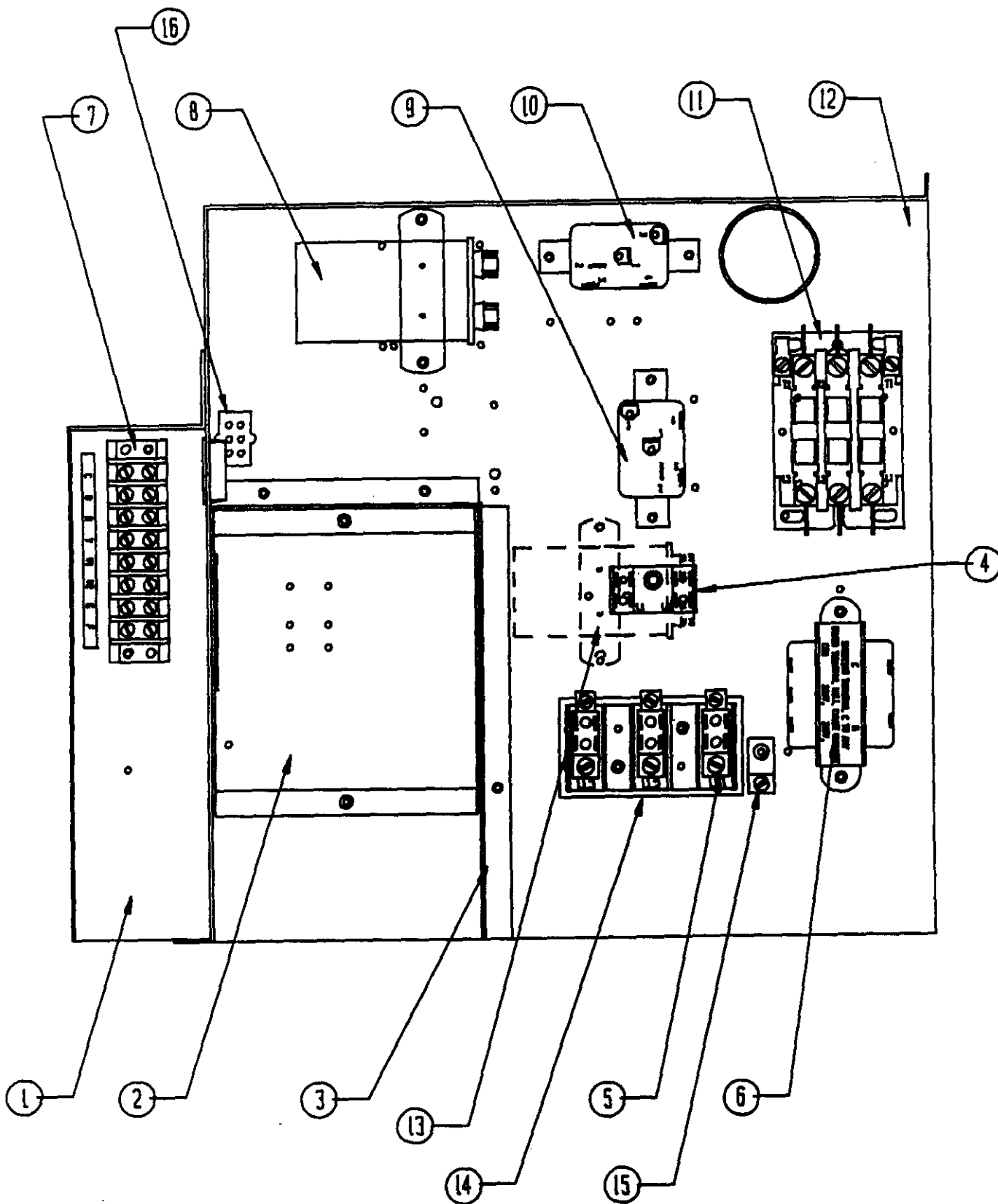

Date: 9-28-89  
Supersedes:

CONTROL PANEL

Dwg. No.	Part No.	Description	P 1 0 4 5 A 1
1	116Y072	Low Voltage Box	X
2	134-095	Terminal Block Shield	X
3	116Y076	Control Panel Partition	X
4	---		
5	8607-013	Terminal Block	X
6	8407-034	Transformer	X
7	8607-006	Terminal Strip	X
8	8552-028	Capacitor 35/440	X
9	8201-008	Blower Relay	X
10	---		
11	8401-007	Contactoer	X
12	516-079	Control Panel	X
13	8552-005	Capacitor 10/370	X
14	---		
15	8611-006	Ground Terminal	X
16	3000-901	Wire Assembly	X
	4064-113	Wiring Diagram	X

Date: 9-28-89  
Supersedes:

