

---

# REPLACEMENT PARTS MANUAL

---

## Wall Mounted Packaged Heat Pump

Models:

C36H1-A	C42H1-A	C48H1-A	C60H1-A
C36H1-B	C42H1-B	C48H1-B	C60H1-B
C36H1-C	C42H1-C	C48H1-C	C60H1-C

---

### General Notes

- Revised and/or additional pages may be issued from time to time.
- A complete and current manual consists of pages shown in the following contents section.

### Important

- Contact the installing and/or local Bard distributor for all parts requirements. Make sure you have the complete model and serial number available from the unit rating plates.

### Contents

<u>Description</u>	<u>Page</u>
Cabinet Components	
♦ Exploded View .....	2
♦ Usage List .....	3
♦ Usage List .....	4
Functional Components	
♦ Exploded View .....	5
♦ Usage List .....	6
♦ Usage List .....	7
Control Panel	
♦ Exploded View .....	8
♦ Usage List .....	9
♦ Usage List .....	10
Blower Assembly	
♦ Exploded View .....	11
♦ Usage List .....	11



*Climate Control Solutions*

Bard Manufacturing Company, Inc.  
Bryan, Ohio 43506  
www.bardhvac.com

Manual: 2110-1504N  
Supersedes: 2110-1504M  
Date: 3-23-21

# CABINET COMPONENTS

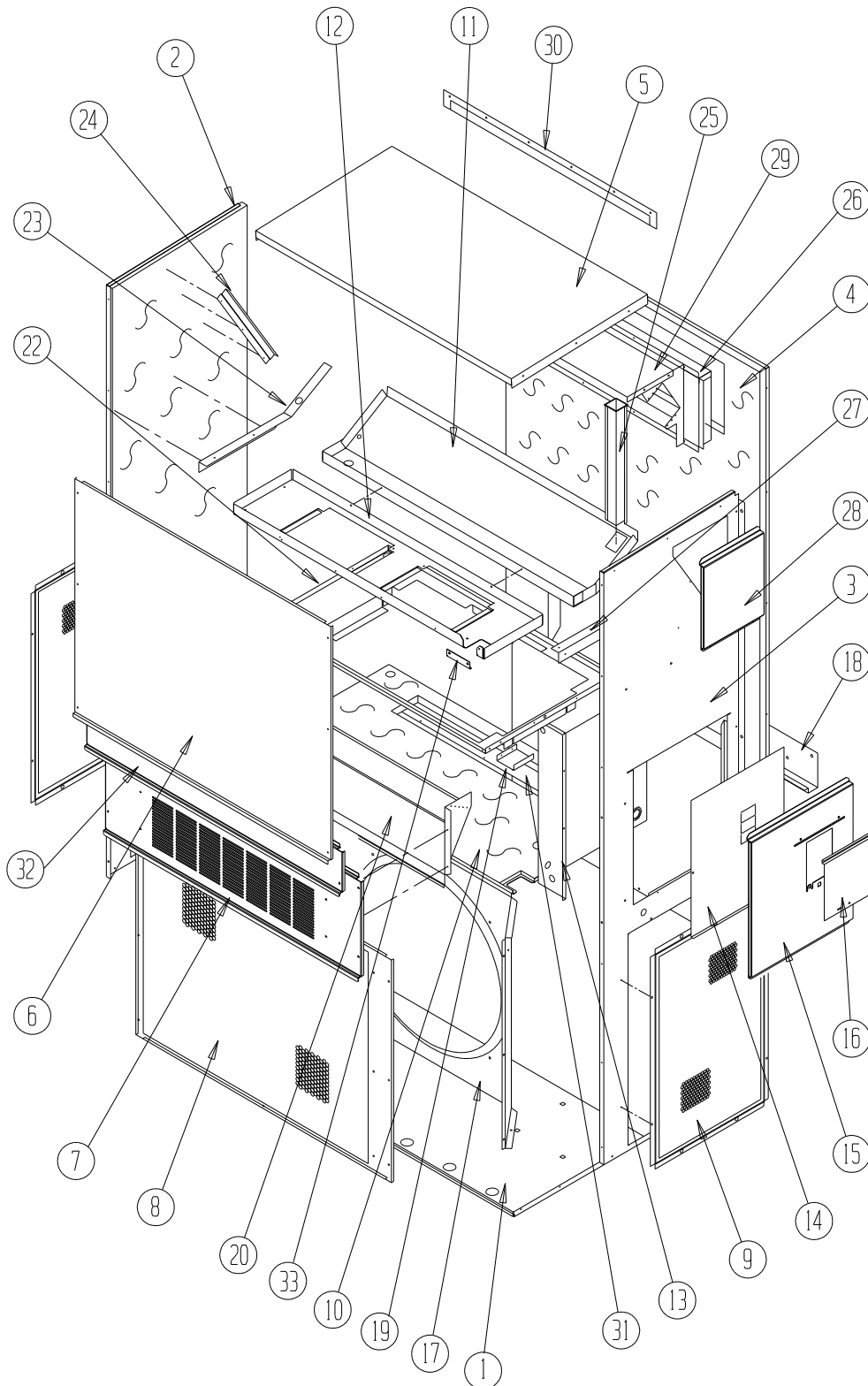

SEXP-658 A

This drawing to be used for reference for pages 3 and 4

# CABINET COMPONENTS

Dwg. No.	Part Number	Description	C36H1-A, -B	C36H1-C	C42H1-A, -B	C42H1-C
1	S127-441	Lower Base	X	X	X	X
1	S127-442 ③	Lower Base	X	X	X	X
2	S501-686-* ①	Left Side	X	X	X	X
2	S501-699 ②	Left Side	X	X	X	X
2	S501-701 ③	Left Side	X	X	X	X
3	S501-677-* ①	Right Side	X	X	X	X
3	S501-698 ②	Right Side	X	X	X	X
3	S501-700 ③	Right Side	X	X	X	X
4	S509-281	Back	X	X	X	X
4	S509-285 ②	Back	X	X	X	X
4	S509-286 ③	Back	X	X	X	X
5	S507-307-* ①	Top	X	X	X	X
5	S506-309 ②	Top	X	X	X	X
5	S507-310 ③	Top	X	X	X	X
6	S515-230-* ①	Upper Front	X	X	X	X
6	S514-231 ②	Upper Front	X	X	X	X
6	S514-232 ③	Upper Front	X	X	X	X
7	S553-522-* ①	Vent Option Door	X	X	X	X
7	S553-529-* ①	Vent Option Door with ERV	X	X	X	X
7	S552-525 ②	Vent Option Door	X	X	X	X
7	S553-527 ③	Vent Option Door	X	X	X	X
8	118-048-* ①	Condenser Grille	X	X	X	X
8	118-064 ②	Condenser Grille	X	X	X	X
8	118-072 ③	Condenser Grille	X	X	X	X
9	118-057-* ①	Side Grille	2	2	2	2
9	118-063 ②	Side Grille	2	2	2	2
9	118-073 ③	Side Grille	2	2	2	2
10	S521-478	Condenser Partition	X	X	X	X
11	S123-122	Drain Pan	X	X	X	X
11	S123-125 ③	Drain Pan	X	X	X	X
12	121X463	Blower Partition	X	X	X	X
13	Control Panel Assembly	See Control Panel Assembly Drawing and Parts List Assembly	X	X	X	X
14	S132-114	Control Panel Cover (Inner)	X		X	
14	S132-347	Control Panel Cover (Inner)		X		X
15	S533-225-* ①	Control Panel Cover (Outer)	X	X	X	X
15	S533-229 ②	Control Panel Cover (Outer)	X	X	X	X
15	S533-230 ③	Control Panel Cover (Outer)	X	X	X	X
16	S153-218-* ①	Disconnect Access Door	X	X	X	X
16	S153-387 ②	Disconnect Access Door	X	X	X	X
16	S153-405 ③	Disconnect Access Door	X	X	X	X
17	125-036	Fan Shroud	X	X	X	X
17	125-067 ③	Fan Shroud	X	X	X	X
18	113-140	Bottom Mounting Bracket	X	X	X	X
19	S919-0007	Fill	X	X	X	X
20	BFAD-5	Fresh Air Damper Assembly	X	X	X	X
22	S137-1006	Filter Tray	X	X	X	X
23	105X877	Left Side Support	X	X	X	X
24	147-046	Left Evaporator Support	X	X	X	X
25	135-128	Raceway	2	2	2	2
26	S111X034	Outlet Air Frame Assembly	X	X	X	X
27	105X878	Right Side Support	X	X	X	X
28	S543-172-* ①	Right Side Cover Plate (Outer)	X	X	X	X
28	S543-176 ②	Right Side Cover Plate (Outer)	X	X	X	X
28	S543-177 ③	Right Side Cover Plate (Outer)	X	X	X	X
29	135-129	Heat Shield	X	X	X	X
30	113-150-* ①	Top Rain Flashing	X	X	X	X
30	113-359-* ③	Top Rain Flashing	X	X	X	X
31	S536-258	Condenser Part. Blank-Off Plate	X	X	X	X
31	S536-489	CRV Blank-Off Plate	X	X	X	X
32	S553-521-* ①	Filter Door Assembly	X	X	X	X
32	S552-526 ②	Filter Door Assembly	X	X	X	X
32	S553-528 ③	Filter Door Assembly	X	X	X	X
33	105-1302	Grommet Retainer	X	X	X	X
NS	141-356	Compressor Mounting Plate	X	X	X	X
NS	111-209	Return Air Plate	X	X	X	X

① Exterior cabinet parts are manufactured with various paint color options. To ensure the proper paint color is received, please reference the following codes:

Beige	-X	White	-1	Buckeye Gray	-4
Desert Brown	-5	Dark Bronze	-8		
② Aluminum	A	③ Stainless Steel	S		

Refer to drawing on page 2

# CABINET COMPONENTS

Dwg. No.	Part Number	Description	C481H-A, -B	C48H1-C	C60H1-A, -B	C60H1-C
1	S127-441	Lower Base	X	X	X	X
1	S127-442 ③	Lower Base	X	X	X	X
2	S501-733-* ①	Left Side	X	X	X	X
2	S501-737 ②	Left Side	X	X	X	X
2	S500-735 ③	Left Side	X	X	X	X
3	S501-732-* ①	Right Side	X	X	X	X
3	S500-736 ②	Right Side	X	X	X	X
3	S500-734 ③	Right Side	X	X	X	X
4	S509-282	Back	X	X	X	X
4	S509-283 ②	Back	X	X	X	X
4	S509-284 ③	Back	X	X	X	X
5	S507-307-* ①	Top	X	X	X	X
5	S506-309 ②	Top	X	X	X	X
5	S506-310 ③	Top	X	X	X	X
6	S515-246-* ①	Upper Front	X	X	X	X
6	S514-254 ②	Upper Front	X	X	X	X
6	S514-253 ③	Upper Front	X	X	X	X
7	S553-522-* ①	Vent Option Door	X	X	X	X
7	S553-529-* ①	Vent Option Door with ERV	X	X	X	X
7	S552-525 ②	Vent Option Door	X	X	X	X
7	S553-527 ③	Vent Option Door	X	X	X	X
8	118-085-* ①	Condenser Grille	X	X	X	X
8	118-087 ②	Condenser Grille	X	X	X	X
8	118-089 ③	Condenser Grille	X	X	X	X
9	118-086-* ①	Side Grille	2	2	2	2
9	118-088 ②	Side Grille	2	2	2	2
9	118-090 ③	Side Grille	2	2	2	2
10	S521-478	Condenser Partition	X	X	X	X
11	S123-122	Drain Pan	X	X	X	X
11	S123-125 ③	Drain Pan	X	X	X	X
12	121X463	Blower Partition	X	X	X	X
13	Control Panel Assembly	See Control Panel Assembly Drawing and Parts List Assembly	X	X	X	X
14	S132-114	Control Panel Cover (Inner)	X		X	
14	S132-347	Control Panel Cover (Inner)		X		X
15	S533-225-* ①	Control Panel Cover (Outer)	X	X	X	X
15	S533-229 ②	Control Panel Cover (Outer)	X	X	X	X
15	S533-230 ③	Control Panel Cover (Outer)	X	X	X	X
16	S153-218-* ①	Disconnect Access Door	X	X	X	X
16	S153-387 ②	Disconnect Access Door	X	X	X	X
16	S153-405 ③	Disconnect Access Door	X	X	X	X
17	125-066	Fan Shroud	X	X	X	X
17	125-067 ③	Fan Shroud	X	X	X	X
18	113-140	Bottom Mounting Bracket	X	X	X	X
19	137-209	Fill	X	X	X	X
20	BFAD-5	Fresh Air Damper Assembly	X	X	X	X
22	131X099	Filter Tray	X	X	X	X
23	105X877	Left Side Support	X	X	X	X
24	147-046	Left Evaporator Support	X	X	X	X
25	135-303	Raceway	2	2	2	2
26	S111X034	Outlet Air Frame Assembly	X	X	X	X
27	105X878	Right Side Support	X	X	X	X
28	S543-172-* ①	Right Side Cover Plate (Outer)	X	X	X	X
28	S543-176 ②	Right Side Cover Plate (Outer)	X	X	X	X
28	S543-177 ③	Right Side Cover Plate (Outer)	X	X	X	X
29	135-129	Heat Shield	X	X	X	X
30	113-150-* ①	Top Rain Flashing	X	X	X	X
30	113-359-* ③	Top Rain Flashing	X	X	X	X
31	S536-258	Condenser Part. Blank-Off Plate	X	X	X	X
31	S536-489	CRV Blank-Off Plate	X	X	X	X
32	S553-521-* ①	Filter Door Assembly	X	X	X	X
32	S552-526 ②	Filter Door Assembly	X	X	X	X
32	S553-528 ③	Filter Door Assembly	X	X	X	X
NS	141-356	Compressor Mounting Plate	X	X	X	X
NS	111-209	Return Air Plate	X	X	X	X

① Exterior cabinet parts are manufactured with various paint color options. To ensure that you receive the proper paint color, please reference the following codes:

Beige	-X	White	-1	Buckeye Gray	-4
Desert Brown	-5	Dark Bronze	-8		
② Aluminum	A	③ Stainless Steel	S		

**Refer to drawing on page 2**

# FUNCTIONAL COMPONENTS

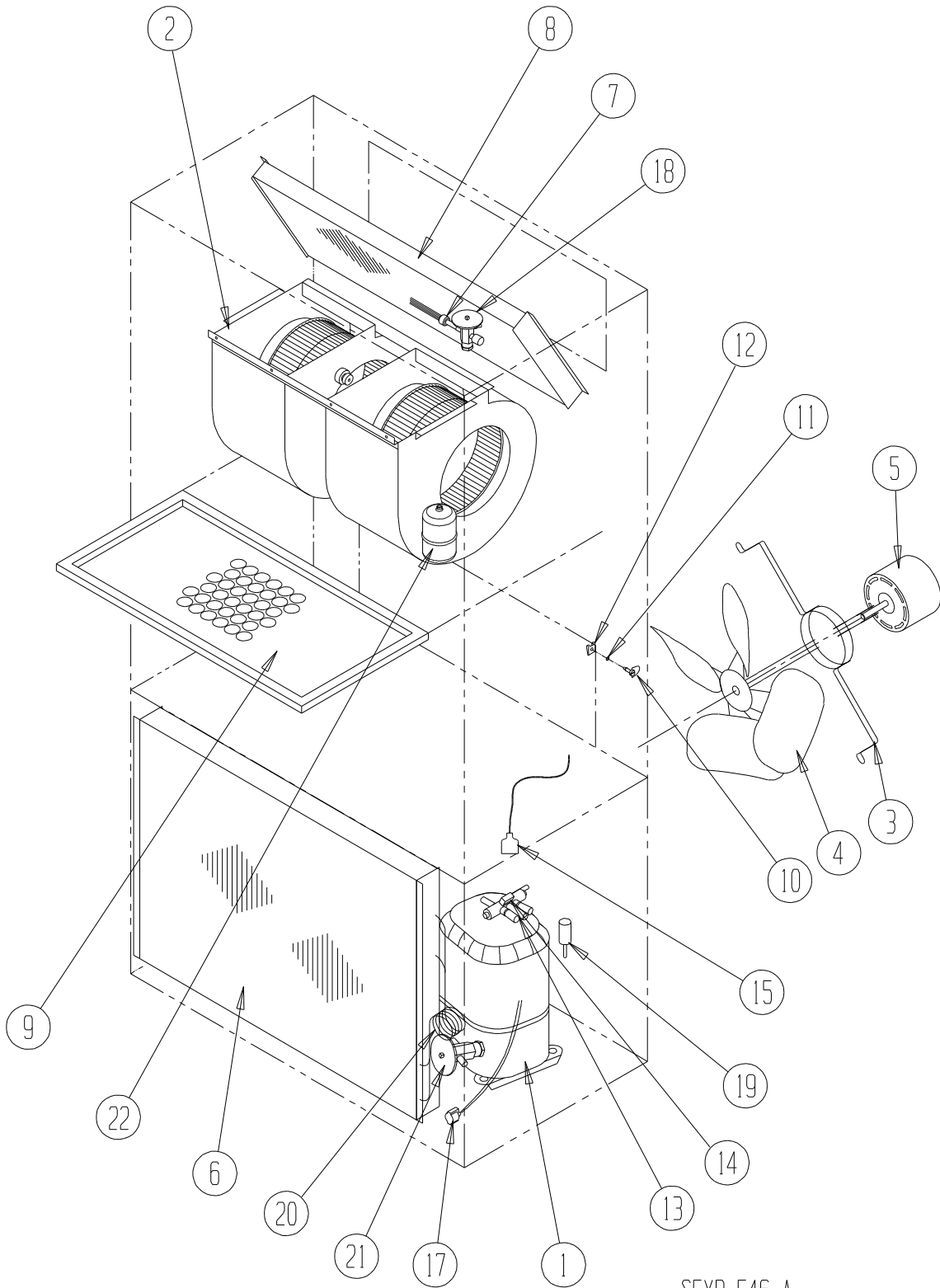

SEXP-546 A

This drawing to be used for reference for pages 6 and 7

# FUNCTIONAL COMPONENTS

Dwg. No.	Part Number	Description	C36H1-A	C36H1-B	C36H1-C	C42H1-A	C42H1-B	C42H1-C
1	8000-379	Compressor	X					
1	8000-380	Compressor		X				
1	8000-381	Compressor			X			
1	8000-391	Compressor				X		
1	8000-392	Compressor					X	
1	8000-393	Compressor						X
2	S900-272-005	Blower Assembly	X	X	X			
2	S900-273-0014	Blower Assembly				X	X	X
3	8200-004	Fan Motor Mount	X	X	X	X	X	X
4	5151-054	Fan Blade	X	X	X	X	X	X
5	8105-068	Condenser Motor	X	X		X	X	
5	8105-071	Condenser Motor			X			X
6	5051-187BX	Condenser Coil	X	X	X			
6	5051-167BX	Condenser Coil				X	X	X
7	800-0342	Cooling Distributor	X	X	X			
7	800-0287	Cooling Distributor				X	X	X
8	5060-164BX	Evaporator Coil	X	X	X	X	X	X
9	7004-016	Air Filter 1" Throw-Away	X	X	X	X	X	X
9	7004-064	Air Filter 2" Pleated MERV 13 ①	X	X	X	X	X	X
9	7004-049	Air Filter 2" Pleated MERV 11 ①	X	X	X	X	X	X
9	7004-027	Air Filter 2" Pleated MERV 8 ①	X	X	X	X	X	X
10	1171-022	1/4" Turn Fastener	X	X	X	X	X	X
11	1171-024	1/4" Turn Retainer	X	X	X	X	X	X
12	1171-023	1/4" Receptacle	X	X	X	X	X	X
13	5650-039	Reversing Valve with 24V Solenoid Coil	X	X	X			
13	5650-040	Reversing Valve with 24V Solenoid Coil				X	X	X
14	5650-042	Rev. Valve Solenoid, Red Casing (Ranco)	X	X	X	X	X	X
14	5650-043	Rev. Valve Solenoid, Black Casing (Wilspec)	X	X	X	X	X	X
14	5650-046	Rev. Valve Solenoid, Black Casing (San Hua)	X	X	X	X	X	X
15	5650-037	Molded Plug 36" Lead	X	X	X	X	X	X
17	8620-224	Defrost Sensor	X	X	X	X	X	X
17	8620-225	Defrost Sensor	X	X	X	X	X	X
18	5651-178	Expansion Valve Cooling	X	X	X	X	X	X
19	1804-0462	High Pressure Switch (Flare) ①	X	X	X	X	X	X
20	800-0432	Heating Distributor Assembly	X	X	X			
20	800-0433	Heating Distributor Assembly				X	X	X
21	5651-216	Expansion Valve Heating	X	X	X	X	X	X
22	5201-010	Filter Drier	X	X	X	X	X	X
NS	5202-022	Suction Accumulator	X	X	X	X	X	X
NS	1804-0107	Low Pressure Switch (Flare) ①	X	X	X	X	X	X
NS	CMH-20	Low Ambient Control (Flare) - 230V ①	X	X		X	X	
NS	CMH-18	Low Ambient Control - 460V ①			X			X
NS	3000-1223	Molded Compressor Plug Low Voltage	X	X	X	X	X	X
NS	3000-1224	Molded Compressor Plug	X			X		
NS	3000-1231	Molded Compressor Plug		X	X		X	X
NS	8002-012	Sound Cover	X	X	X	X	X	X
NS	8408-039	Discharge Line Thermostat	X	X	X	X	X	X
NS	5220-013	Discharge Muffler	X	X	X	X	X	X
NS	6031-009	Coremax Valve Core	X	X	X	X	X	X
NS	8407-003	Stepdown Transformer 480V/240V 1.5KVA			X			X

NS – Not Shown

① – Optional

Refer to drawing on page 5

# FUNCTIONAL COMPONENTS

Dwg. No.	Part Number	Description	C48H1-A	C48H1-B	C48H1-C	C60H1-A	C60H1-B	C60H1-C
1	8000-382	Compressor	X					
1	8000-383	Compressor		X				
1	8000-384	Compressor			X			
1	8000-385	Compressor				X		
1	8000-386	Compressor					X	
1	8000-387	Compressor						X
2	S900-273-0013	Blower Assembly	X	X	X			
2	S900-273-0012	Blower Assembly				X	X	X
3	8200-004	Fan Motor Mount	X	X	X	X	X	X
4	5151-054	Fan Blade	X	X	X	X	X	X
5	8105-068	Condenser Motor	X	X				
5	8105-071	Condenser Motor			X			
5	S8106-053-0097	Condenser Motor				X	X	X
6	5051-169BX	Condenser Coil	X	X	X	X	X	X
7	800-0417	Cooling Distributor	X	X	X	X	X	X
8	917-0190BX	Evaporator Coil	X	X	X	X	X	X
9	7004-016	Air Filter 1" Throw-Away	X	X	X	X	X	X
9	7004-049	Air Filter 2" Pleated MERV 11 ①	X	X	X	X	X	X
9	7004-031	Air Filter 2" Pleated MERV 8 ①	X	X	X	X	X	X
9	7004-027	Air Filter 2" Pleated MERV 6 ①	X	X	X	X	X	X
10	1171-022	1/4" Turn Fastener	X	X	X	X	X	X
11	1171-024	1/4" Turn Retainer	X	X	X	X	X	X
12	1171-023	1/4" Receptacle	X	X	X	X	X	X
13	5650-040	Reversing Valve with 24V Solenoid Coil	X	X	X	X	X	X
14	5650-042	Rev. Valve Solenoid, Red Casing (Ranco)	X	X	X	X	X	X
14	5650-043	Rev. Valve Solenoid, Black Casing (Wilspec)	X	X	X	X	X	X
14	5650-046	Rev. Valve Solenoid, Black Casing (San Hua)	X	X	X	X	X	X
15	5650-037	Molded Plug 3/6" Lead	X	X	X	X	X	X
17	8620-225	Defrost Sensor	X	X	X	X	X	X
18	5651-184	Expansion Valve Cooling	X	X	X			
18	5651-199	Expansion Valve Cooling				X	X	X
19	1804-0462	High Pressure Switch (Flare) ①	X	X	X	X	X	X
20	800-0414	Heating Distributor Assembly	X	X	X	X	X	X
21	5651-184	Expansion Valve Heating	X	X	X			
21	5651-199	Expansion Valve Heating				X	X	X
22	5201-010	Filter Drier	X	X	X	X	X	X
NS	1804-0107	Low Pressure Switch (Flare) ①	X	X	X	X	X	X
NS	CMH-18	Low Ambient Control - 460V ①			X			
NS	CMH-19	Low Ambient Control (Flare) ①				X	X	X
NS	CMH-20	Low Ambient Control (Flare) - 230V ①	X	X				
NS	3000-1223	Molded Compressor Plug Low Voltage	X	X	X	X	X	X
NS	3000-1224	Molded Compressor Plug	X			X		
NS	3000-1231	Molded Compressor Plug		X	X		X	X
NS	8002-013	Sound Cover	X	X	X	X	X	X
NS	8408-039	Discharge Line Thermosat	X	X	X	X	X	X
NS	5220-013	Discharge Muffler	X	X	X	X	X	X
NS	6031-009	Coremax Valve Core	X	X	X	X	X	X
NS	8407-003	Stepdown Transformer 480V/240V 1.5KVA			X			
NS	8407-004	Stepdown Transformer 480V/240V 2.0KVA						X

NS – Not Shown

① – Optional

Refer to drawing on page 5

# CONTROL PANEL

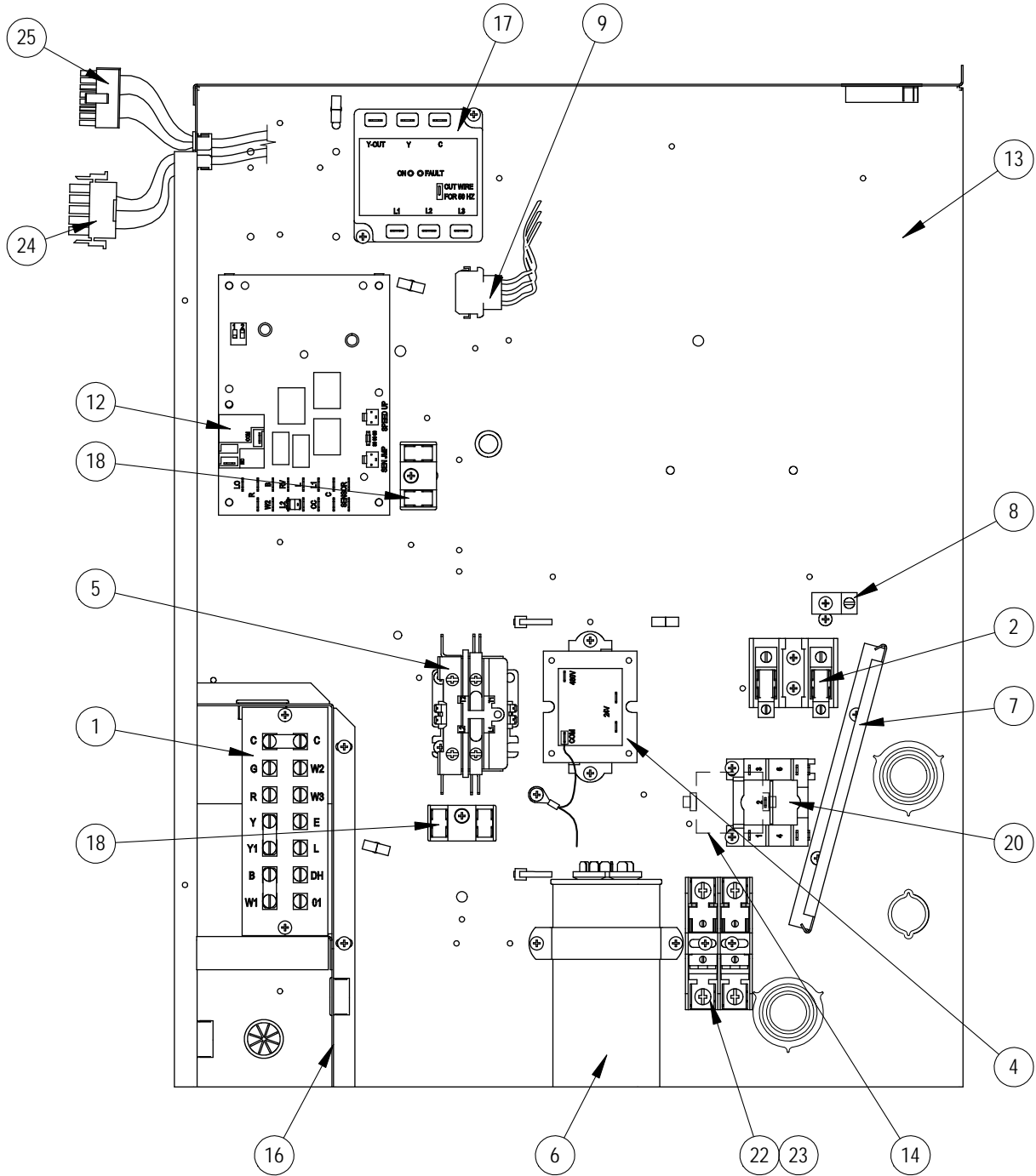

SEXP-668

This drawing to be used for reference for pages 9 and 10



# CONTROL PANEL

Dwg. No.	Part Number	Description	C36H1-A	C36H1-B	C36H1-C	C42H1-A	C42H1-B	C42H1-C
1	8607-031	Low Voltage Terminal Strip	X	X	X	X	X	X
2	8607-013	Terminal Block 2 Pole	X			X		
2	8607-014	Terminal Block 3 Pole		X	X		X	X
2	8607-015	Phenolic Insulator			X			X
4	8407-065	Transformer	X	X		X	X	
4	8407-050	Transformer			X			X
5	8401-002	Compressor Contactor		X	X		X	X
5	8401-025	Compressor Contactor	X			X		
6	8552-005	Outdoor Motor Capacitor		X			X	
6	8552-080	Compressor Capacitor	X			X		
6	8552-004	Outdoor Motor Capacitor			X			X
7	135-130	Wire Shield	X	X	X	X	X	X
8	8611-006	Ground Terminal	X	X	X	X	X	X
9	3000-1324	6 Pin Connector	X	X	X	X	X	X
10	8201-086	Low Ambient Bypass Relay ①	X	X	X	X	X	X
12	8620-223	Defrost Board Replacement Kit	X	X	X	X	X	X
13	117-289	Control Panel (Sheet Metal Only)	X	X	X	X	X	X
14	8551-004	Start Device ① PTCR	X			X		
16	117X139	Low Voltage Box	X	X	X	X	X	X
17	8201-126	Phase Monitor		X	X		X	X
18	8607-017	Terminal Block ①	X	X	X	X	X	X
20	8201-032	Outdoor Fan Relay			X			X
22	8614-041	Fuse Block			X			
23	8614-046	Fuse			2			2
24	3000-1221	Blower Wire Harness Power	X	X	X	X	X	X
25	3000-1390	Blower Wire Harness Control	X	X	X	X	X	X
NS	4096-160	Wiring Diagram	X			X		
NS	4096-260	Wiring Diagram		X			X	
NS	4096-360	Wiring Diagram			X			X
NS	8615-055	Circuit Breaker 40A 2 Pole (OZ)	X			X		
NS	8615-052	Circuit Breaker 35A 3 Pole (OZ)		X			X	
NS	S8615-101	Rotary Disconnect (OZ)			X			X

NS – Not Shown

① – Optional

Refer to drawing on page 8

# CONTROL PANEL

Dwg. No.	Part Number	Description	C48H1-A	C48H1-B	C48H1-C	C60H1-A	C60H1-B	C60H1-C
1	8607-031	Low Voltage Terminal Strip	X	X	X	X	X	X
2	8607-013	Terminal Block 2 Pole	X			X		
2	8607-014	Terminal Block 3 Pole		X	X		X	X
2	8607-015	Phenolic Insulator			X			X
4	8407-065	Transformer	X	X		X	X	
4	8407-050	Transformer			X			X
5	8401-002	Compressor Contactor		X	X		X	X
5	8401-025	Compressor Contactor	X			X		
6	8552-005	Outdoor Motor Capacitor		X				
6	8552-094	Compressor Capacitor	X					
6	8552-004	Outdoor Motor Capacitor			X			
6	8552-051	Compressor Capacitor				X		
7	135-130	Wire Shield	X	X	X	X	X	X
8	8611-006	Ground Terminal	X	X	X	X	X	X
9	3000-1324	6 Pin Connector	X	X	X	X	X	X
10	8201-086	Low Ambient Bypass Relay ①	X	X	X	X	X	X
12	8620-223	Defrost Board Replacement Kit	X	X	X	X	X	X
13	117-309	Control Panel (Sheet Metal Only)	X	X	X	X	X	X
14	8551-004	Start Device ① PTCR	X			X		
16	117-312	Low Voltage Box	X	X	X	X	X	X
17	8201-126	Phase Monitor		X	X		X	X
18	8607-017	Terminal Block ①	X	X	X	X	X	X
20	8201-032	Outdoor Fan Relay			X			X
22	8614-041	Fuse Block			X			
23	8614-046	Fuse			2			2
23	8614-042	Fuse						2
24	3000-1221	Blower Wire Harness Power	X	X	X	X	X	X
25	3000-1390	Blower Wire Harness Control	X	X	X	X	X	X
NS	4096-160	Wiring Diagram	X					
NS	4096-260	Wiring Diagram		X				
NS	4096-360	Wiring Diagram			X			
NS	4096-162	Wiring Diagram				X		
NS	4096-262	Wiring Diagram					X	
NS	4096-362	Wiring Diagram						X
NS	8615-040	Circuit Breaker 50A 2 Pole (OZ)	X					
NS	8615-041	Circuit Breaker 60A 2 Pole (OZ)				X		
NS	8615-043	Circuit Breaker 40A 3 Pole (OZ)		X			X	
NS	S8615-101	Rotary Disconnect (OZ)			X			X

NS – Not Shown

① – Optional

Refer to drawing on page 8

# BLOWER ASSEMBLY

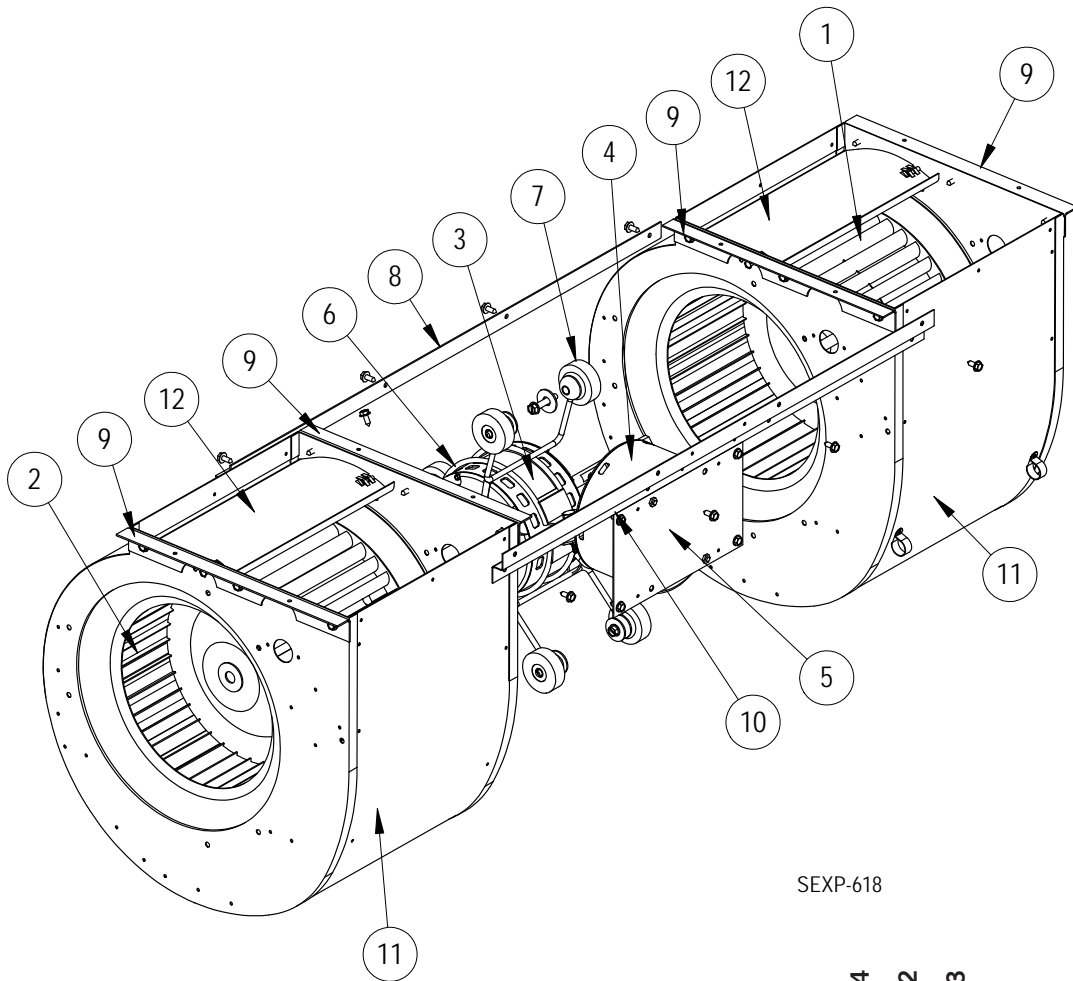

SEXP-618

Dwg. No.	Part Number	Description	S900-272-005	S900-273-0014	S900-273-0012	S900-273-0013
1	5152-011	10-Inch Wheel (CW)	X	X	X	X
2	5152-012	10-Inch Wheel (CCW)	X	X	X	X
3	S8106-052-0100	1/2 HP Programmed Motor	X			
3	S8107-017-0121	3/4 HP Programmed Motor		X		
3	S8107-017-0098	3/4 HP Programmed Motor			X	
3	S8107-017-0099	3/4 HP Programmed Motor				X
4	C8106-052-0100	Programmed Motor Control Only	X			
4	C8107-017-0121	Programmed Motor Control Only		X		
4	C8107-017-0098	Programmed Motor Control Only			X	
4	C8107-017-0099	Programmed Motor Control Only				X
5	112-344	Blower Motor Control Bracket	X	X	X	X
6	8200-040	Motor Mount	X	X	X	X
7	5451-011	Grommets	6	6	6	6
8	105-881	Back Brace	X	X	X	X
9	105-880	Side Angle	4	4	4	4
10	103-389	Front Brace	X	X	X	X
11	151-101	Housing	2	2	2	2
12	144-166	Diffuser	2	2	2	2