REPLACEMENT PARTS MANUAL

MULTI-TEC® WALL-MOUNT AIR CONDITIONER

Models:

W30LBPA W30LBPC W36LBPA W36LBPC
W30LBPB W30LBPF W36LBPB W36LBPF

Contents

Description	Page	Description	Page
Cabinet Components		Freecooling Air Hood	
♦ Exploded View	2	♦ Exploded View	10
♦ Usage List	3	♦ Usage List	10
Functional Components		Freecooling Damper Motor	
♦ Exploded View	4	♦ Exploded View	11
♦ Usage List	5	♦ Usage List	11
Control Panel			
♦ Layout View	6		
♦ Usage List	7		
Blower Assembly			
♦ Exploded View	8		
♦ Usage List	8		
Freecooling Components			
♦ Exploded View	9		
♦ Usage List	9		

General Notes

- Revised and/or additional pages may be issued from time to time.
- A complete and current manual consists of pages shown in the contents section.

Important

- Contact the installing and/or local Bard distributor for all parts requirements. Make sure to have the complete model and serial number available from the unit rating plates.



Bard Manufacturing Company, Inc.
Bryan, Ohio 43506
www.bardhvac.com

Manual: 2110-1459
Supersedes: **NEW**
Date: 10-22-19

CABINET COMPONENTS

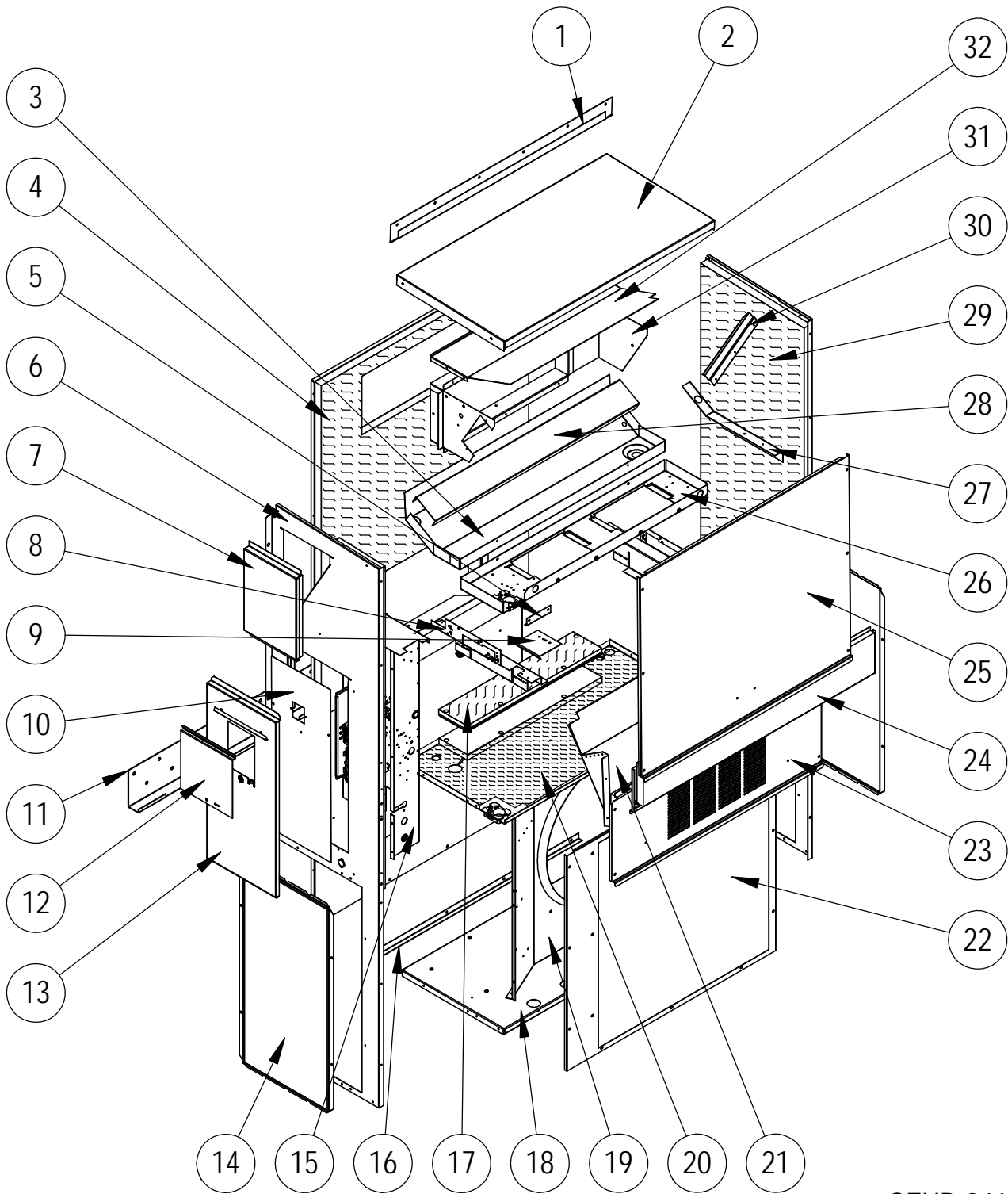

SEXP-946

CABINET COMPONENTS

Dwg No.	Part Number	Description	W30LBPA, B	W30LBPC	W30LBPF	W36LBPA, B	W36LBPC	W36LBPF
1	113-149-* ①	Top Rain Flashing	X	X	X	X	X	X
1	113-360 ②	Top Rain Flashing	X	X	X	X	X	X
1	113-149-4 ③	Top Rain Flashing	X	X	X	X	X	X
2	S507-308-* ①	Top	X	X	X	X	X	X
2	S507-319 ②	Top	X	X	X	X	X	X
2	S507-320 ③	Top	X	X	X	X	X	X
3	S123-130	Drain Pan	X	X	X	X	X	X
3	S123-143 ②③	Drain Pan	X	X	X	X	X	X
4	S508-343	Back	X	X	X	X	X	X
4	S508-388 ②	Back	X	X	X	X	X	X
4	S508-345 ③	Back	X	X	X	X	X	X
5	105-1302	Grommet Retainer	X	X	X	X	X	X
6	S501-935-* ①	Right Side	X	X	X	X	X	X
6	S501-998 ②	Right Side	X	X	X	X	X	X
6	S501-943 ③	Right Side	X	X	X	X	X	X
7	S543-175-* ①	Right Side Cover Plate (Outer)	X	X	X	X	X	X
7	S543-185 ②	Right Side Cover Plate (Outer)	X	X	X	X	X	X
7	S543-184 ③	Right Side Cover Plate (Outer)	X	X	X	X	X	X
8	113Y480	Filter Bracket	2	2	2	2	2	2
9	137-259	Fill Plate	X	X	X	X	X	X
10	S132-104	Control Panel Cover (Inner)	X			X		
10	S132-172	Control Panel Cover (Inner)		X	X		X	X
11	113-140	Bottom Mounting Bracket	X	X	X	X	X	X
12	S153-218 ①	Disconnect Access Door	X	X	X	X	X	X
12	S153-405 ②	Disconnect Access Door	X	X	X	X	X	X
12	S153-387 ③	Disconnect Access Door	X	X	X	X	X	X
13	S533-228 ①	Control Panel Cover (Outer)	X	X	X	X	X	X
13	S533-235 ②	Control Panel Cover (Outer)	X	X	X	X	X	X
13	S533-236 ③	Control Panel Cover (Outer)	X	X	X	X	X	X
14	118-124-* ①	Side Grille	2	2	2	2	2	2
14	118-140 ②	Side Grille	2	2	2	2	2	2
14	118-139 ③	Side Grille	2	2	2	2	2	2
15	Control Panel Assembly	See Control Panel Assy. Drawing & Parts List Assy.	X	X	X	X	X	X
16	105-1393	Close Off Angle	X	X	X	X	X	X
17	S536-498	Cond. Partition Block Off Plate	X	X	X	X	X	X
17	S536-877 ②	Cond. Partition Block Off Plate	X	X	X	X	X	X
18	S127-472	Lower Base	X	X	X	X	X	X
18	S127-533 ②	Lower Base	X	X	X	X	X	X
19	125-081	Fan Shroud	X	X	X	X	X	X
19	125-083 ②	Fan Shroud	X	X	X	X	X	X
20	S521Y527	Condenser Partition	X	X	X	X	X	X
20	S521*-561 ②	Condenser Partition	X	X	X	X	X	X
22	118-104-* ①	Condenser Grille	X	X	X	X	X	X
22	118-109 ②	Condenser Grille	X	X	X	X	X	X
22	118-114 ③	Condenser Grille	X	X	X	X	X	X
23	S553-523-* ①	Vent Option Door	X	X	X	X	X	X
23	S553-549 ②	Vent Option Door	X	X	X	X	X	X
23	S553-550 ③	Vent Option Door	X	X	X	X	X	X
24	S553-524-* ①	Filter Door	X	X	X	X	X	X
24	S553-553 ②	Filter Door	X	X	X	X	X	X
24	S553-554 ③	Filter Door	X	X	X	X	X	X
25	S514-241-* ①	Upper Front	X	X	X	X	X	X
25	S514-238 ②	Upper Front	X	X	X	X	X	X
25	S514-239 ③	Upper Front	X	X	X	X	X	X
26	121Y467	Blower Partition	X	X	X	X	X	X
27	105Y850	Side Support	X	X	X	X	X	X
28	137-685	Bottom Evaporator Fill	X	X	X	X	X	X
29	S501-936-* ①	Left Side	X	X	X	X	X	X
29	S501-999 ②	Left Side	X	X	X	X	X	X
29	S501-946 ③	Left Side	X	X	X	X	X	X
30	147-044	Evaporator Support	X	X	X	X	X	X
31	S111Y030	Outlet Air Frame Assembly	X	X	X	X	X	X
32	135Y123	Heat Shield	X	X	X	X	X	X
NS	135-329	Air Baffle	X	X	X	X	X	X
NS	BOP-3	Blank Off Plate	X	X	X	X	X	X
NS	5252-033	Bard Nameplate	X	X	X	X	X	X

① Exterior cabinet parts are manufactured with various paint color options. To ensure the proper paint color is received, include the complete model and serial number of the unit for which cabinet parts are being ordered.

② Exterior cabinet parts are manufactured from stainless steel Code "S"

③ Exterior cabinet parts are manufactured from aluminum Code "A"

FUNCTIONAL COMPONENTS

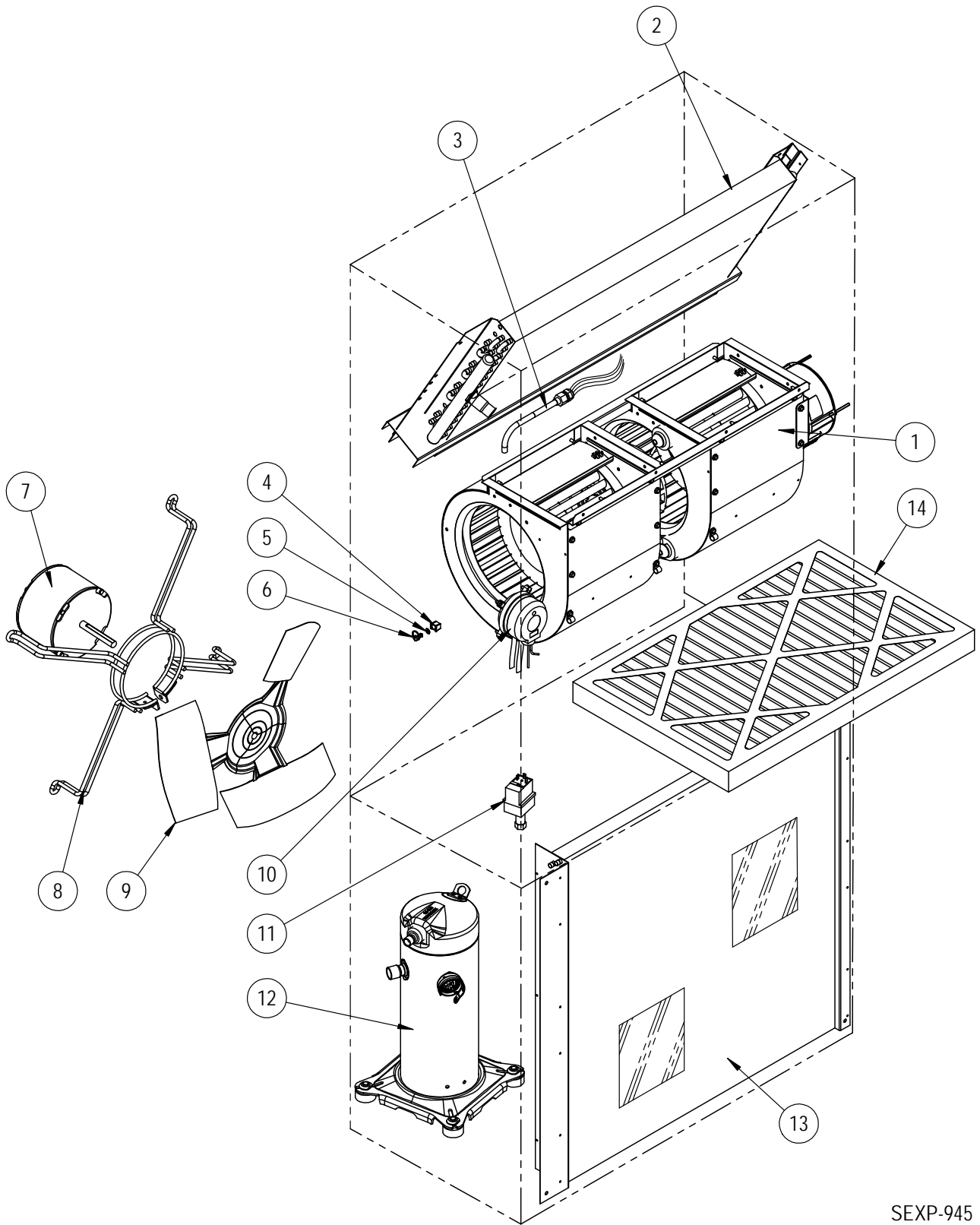

SEXP-945

FUNCTIONAL COMPONENTS

Dwg No.	Part Number	Description	W30LBPA	W30LBPB	W30LBPC	W30LBPF	W36LBPA	W36LBPB	W36LBPC	W36ABPF
1	S900-364-001	Blower Assembly	X	X		X				
1	S900-365-001	Blower Assembly			X					
1	900-364-002	Blower Assembly					X	X		X
1	900-365-002	Blower Assembly							X	
2	917-0355	Evaporator Coil w/Distributor Assy.	X	X	X	X				
2	917-0356	Evaporator Coil – Coated w/Distributor Assy.	X	X	X	X				
2	917-0357	Evaporator Coil w/Distributor Assy.					X	X	X	X
2	917-0358	Evaporator Coil – Coated w/Distributor Assy.					X	X	X	X
3	800-0456	Distributor Assembly					X	X	X	X
3	800-0479	Distributor Assembly	X	X	X	X				
4	1171-023	1/4" Receptacle	X	X	X	X	X	X	X	X
5	1171-024	1/4" Turn Retainer	X	X	X	X	X	X	X	X
6	1171-022	1/4" Turn Fastener	X	X	X	X	X	X	X	X
7	8103-029	Condenser Motor	X	X		X	X	X		X
7	8103-030	Condenser Motor			X				X	
8	8200-001	Fan Motor Mount	X	X	X	X	X	X	X	X
8	8200-050 ①	Stainless Steel Fan Motor Mount	X	X	X	X	X	X	X	X
9	S5151-045	Fan Blade	X	X	X	X	X	X	X	X
9	S5151C045 ①	Coated Fan Blade	X	X	X	X	X	X	X	X
10	CMA-31	Dirty Filter Switch Kit	X	X	X	X	X	X	X	X
11	CMA-39	Low Ambient Control (Screw On) ②	X	X	X	X	X	X	X	X
12	8000-277	Compressor	X							
12	8000-365	Compressor		X						
12	8000-366	Compressor			X	X				
12	8000-278	Compressor					X			
12	8000-283	Compressor						X		
12	8000-342	Compressor							X	X
13	5051-203BX	Condenser Coil	X	X	X	X				
13	5054-203BX	Condenser Coil – Coated	X	X	X	X				
13	5051-202BX	Condenser Coil					X	X	X	X
13	5054-202BX	Condenser Coil – Coated					X	X	X	X
14	7004-019	Air Filter 1" Throw-Away (16x30x1)	X	X	X	X	X	X	X	X
14	7003-031	Air Filter 1" Washable ② (16x30x1)	X	X	X	X	X	X	X	X
14	7004-026	Air Filter 2" Pleated ② (16x30x2)	X	X	X	X	X	X	X	X
14	7004-048	Air Filter 2" Pleated – MERV 11 ② (16x30x2)	X	X	X	X	X	X	X	X
14	7004-062	Air Filter 2" Pleated – MERV 13 ② (16x30x2)	X	X	X	X	X	X	X	X
NS	8406-142	High Pressure Switch (Screw On)	X	X	X	X	X	X	X	X
NS	8406-140	Low Pressure Switch (Screw On)	X	X	X	X	X	X	X	X
NS	5201-021	Filter Drier	X	X	X	X	X	X	X	X
NS	5451-024	Tubing Isolation Grommet	X	X	X	X	X	X	X	X
NS	6031-009	Coremax Valve Core	X	X	X	X	X	X	X	X
NS	1171-070	Filter Door Clip	X	X	X	X	X	X	X	X
NS	1171-068	Filter Door Screw	X	X	X	X	X	X	X	X
NS	1171-069	Filter Door Screw Retainer	X	X	X	X	X	X	X	X

NS – Not Shown

① – Used with stainless steel cabinet option

② – Optional on these models

CONTROL PANEL

Dwg No.	Part Number	Description	W30LAPA	W30LAPB	W30LAPC	W30LAPF	W36LAPA	W36LAPB	W36LAPC	W36LAPF
1	117Y137	Control Panel Top	X	X	X	X	X	X	X	X
2	117Y395	Control Panel	X	X	X	X	X	X	X	X
3	135-122	Wire Shield	X	X	X	X	X	X	X	X
4	8201-130	Blower Relay	X	X	X	X	X	X	X	X
5	3020-004	Communications Sheathed Cable	X	X	X	X	X	X	X	X
6	8201-126	3 Phase Line Monitor 50/60 Hz		X	X	X		X	X	X
7	8201-130	Alarm Relay	X	X	X	X	X	X	X	X
8	8201-164	Compressor Control Module	X	X	X	X	X	X	X	X
9	8301-057	Filter Switch w/Adjustment	X	X	X	X	X	X	X	X
10	8301-068-001*	UPC3-MULTI-TEC 2.0.0	X	X	X	X	X	X	X	X
11	8401-035	Contactor 3-Pole 25 Amp		X	X	X		X	X	X
11	8401-038	Contactor 2-Pole 40 Amp	X				X			
12	8401-039	Aux. NC Contact		X	X	X		X	X	X
13	8407-048	Transformer 208/240-24 75VA	X	X		X	X	X		X
13	8407-050	Transformer 480/24VAC 75VA			X				X	
14	8607-013	Terminal Block 2 Term. 240V				X				X
15	8607-017	Terminal Block 240V 2 Terminal	X	X	X	X	X	X	X	X
16	8607-037	Terminal Block 4 Position	X	X	X	X	X	X	X	X
17	8607-041	Park Terminal	X	X	X	X	X	X	X	X
18	8611-006	Ground Terminal	X	X	X	X	X	X	X	X
19	8611-140-1200	2-1/4" x 1" Cable Duct x 12"	X	X	X	X	X	X	X	X
20	8611-147	3-Pin Circuit Board Connector	X	X	X	X	X	X	X	X
21	8611-148	4-Pin Circuit Board Connector	X	X	X	X	X	X	X	X
22	8611-149	9-Pin Circuit Board Connector	X	X	X	X	X	X	X	X
23	8611-185	8-Pin Circuit Board Connector	X	X	X	X	X	X	X	X
24	8611-189	35MM DIN Rail 9"	X	X	X	X	X	X	X	X
25	8611-192	Small 3-Pin Circuit Board Connector	X	X	X	X	X	X	X	X
26	910-1935	Evap. Temp. Sensor Assembly	X	X	X	X	X	X	X	X
27	8611-183	2-Pin Circuit Board Connector	X	X	X	X	X	X	X	X
28	8611-150	DIN Rail Terminal Block	X	X	X	X	X	X	X	X
29	8552-052	Compressor Capacitor	X				X			
29	8552-002	Outdoor Motor Capacitor		X	X	X		X	X	X
NS	3000-1224	Compressor Plug/Harness	X				X			
NS	3000-1231	Compressor Plug/Harness		X	X	X		X	X	X
NS	8615-038	Circuit Breaker 35A 2 Pole (Opt.) ①	X				X			
NS	8615-054	Circuit Breaker 20A 3 Pole (Opt.) ①		X						
NS	8615-052	Circuit Breaker 30A 3 Pole (Opt.) ①						X		
NS	8615-067	Toggle Disconnect (Opt.) ①			X	X			X	X
NS	4207-100A	Wiring Diagram	X				X			
NS	4207-200A	Wiring Diagram		X				X		
NS	4207-300A	Wiring Diagram			X				X	
NS	4207-600A	Wiring Diagram				X				X
NS	8301-075	USB Micro Cable Female to Male	X	X	X	X	X	X	X	X

* Replacement part will have a letter attached to the end of the part number to designate software version (Example: 8301-068-001**A**). A software upgrade of all PLCs onsite (units and controllers) should accompany any PLC replacement. Latest revisions of software, change log and instructions are available on the Bard website at <http://www.bardhvac.com/software-download/>

① Circuit breakers listed are for units without electric heat, "OZ" models. Hot gas bypass models not available without electric heat. See heater replacement parts manual for units with electric heat.

NS = Not Shown

BLOWER ASSEMBLY

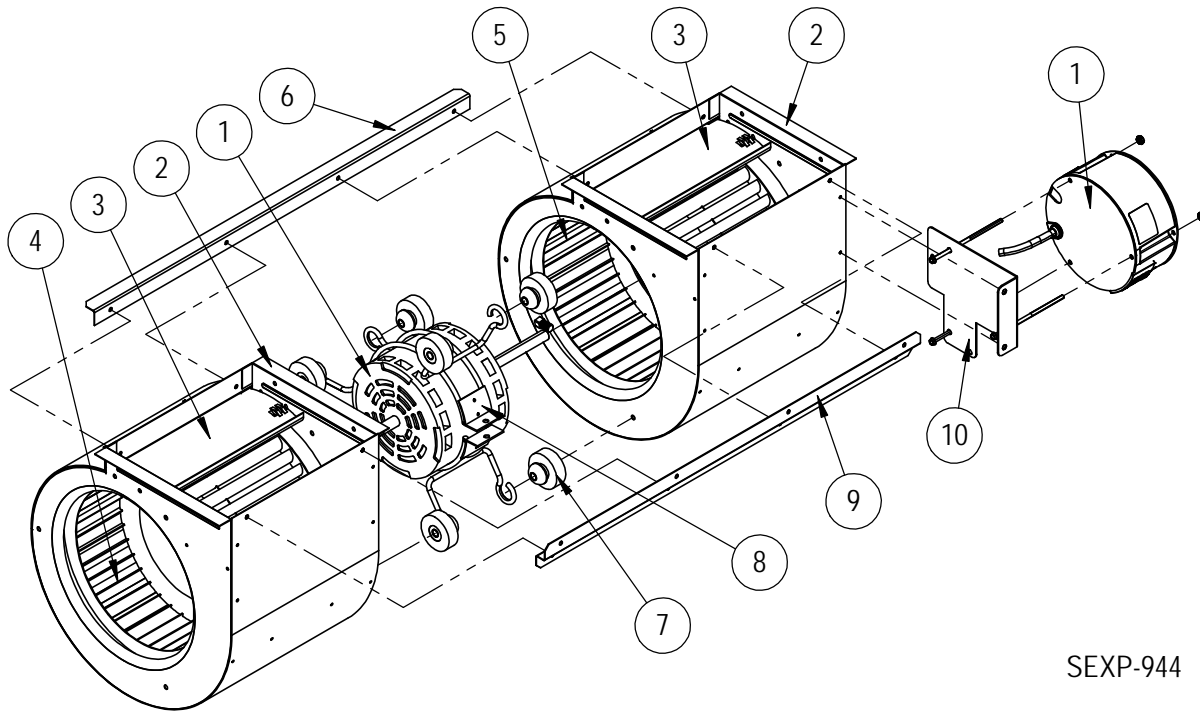

SEXP-944

Dwg No.	Part Number	Description	S900-364-001	S900-364-002	S900-365-001	S900-365-002
1	S8106-068-0150	Programmed Blower Motor & Control (230/208V)	X			
1	S8106-068-0152	Programmed Blower Motor & Control (230/208V)		X		
1	S8106-069-0151	Programmed Blower Motor & Control (460V)			X	
1	S8106-069-0153	Programmed Blower Motor & Control (460V)				X
1	C8106-068-0150	Programmed Control Only (230/208V)	0			
1	C8106-068-0152	Programmed Control Only (230/208V)		0		
1	C8106-069-0151	Programmed Control Only (460V)			0	
1	C8106-069-0153	Programmed Control Only (460V)				0
2	151-111	Housing	2	2	2	2
3	144-174	Diffuser	2	2	2	2
4	5152-090	Wheel CW	X	X	X	X
5	5152-091	Wheel CCW	X	X	X	X
6	105-870	Back Brace	X	X	X	X
7	5451-011	Grommets	6	6	6	6
8	8200-031	Motor Mount	X	X	X	X
9	103-401	Front Brace	X	X	X	X
10	113-761	Motor Control Bracket	X	X	X	X

FREECOOLING COMPONENTS

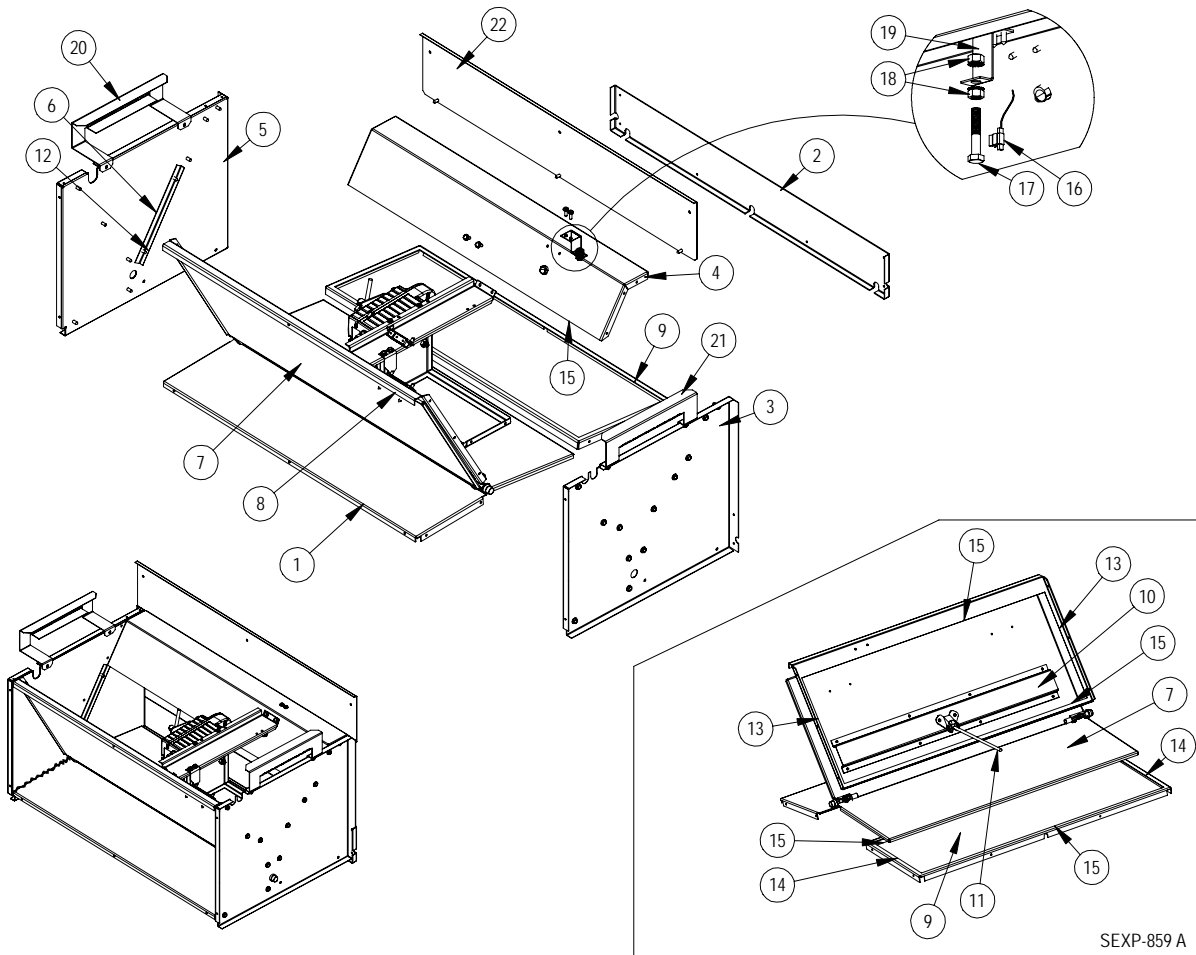

SEXP-859 A

Dwg. No.	Part Number	Description
1	137-738	Lower Front Partition
2	137-745	Lower Rear Fill
3	S101-979	Right Side
4	S137-865	Upper Rear Partition
5	S101-978	Left Side
6	S105-1344	Blade Seal Angle
7	S139-324	Blade
8	S137-867	Upper Front Partition
9	S137-740	Lower Rear Partition
10	141-430	Blade Support
11	8602-044	1/4 x 9" Rod
12	S1921-067-0800	29-9/16" Damper Blade Seal
13	S1921-067-1004	13" Damper Blade Seal
14	S1921-067-0802	10-11/16" Damper Blade Seal
15	S1921-067-2504	29-3/8" Damper Blade Seal
16	8408-044	Sensor 10K Ohm Curve J w/ 5/16" Clip
17	1012-052	Hex Head Bolt 5/16 - 18x1-3/4" 0.0005 Zinc w/ Yellow Chromate
18	1012-210	5/16" Nut 0.0005 Zinc w/ Yellow Chromate
19	113-541	Sensor Bracket
20	113-542	Filter Bracket
21	113-543	Filter Bracket
22	137-746	Upper Rear Fill
23	8602-040	Rod Bracket
NS	537-751	Condenser Cover Plate Assembly

FREECOOLING AIR HOOD

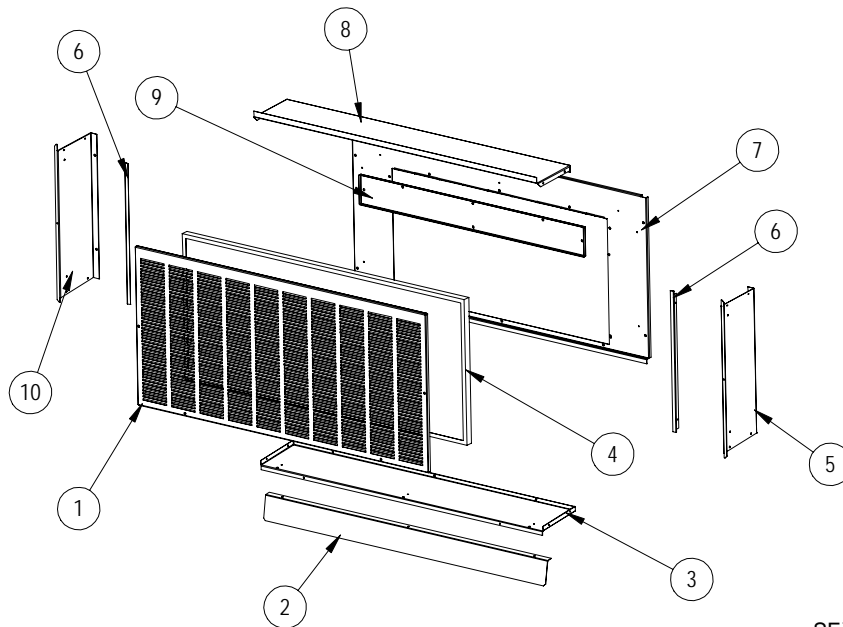

SEXP-752A

Dwg. No.	Part Number	Description
1	115-284-* ①	Hooded Front Door
1	115-291 ②	Hooded Front Door
1	115-290 ③	Hooded Front Door
2	113-538-* ①	Bottom Divider Bracket
2	113-568 ②	Bottom Divider Bracket
2	113-571 ③	Bottom Divider Bracket
3	S127-495-* ①	Hood Bottom
4	7003-079	Mist Filter 36-1/4" x 15-7/8" x 7/8"
5	S101-984-* ①	Right Side
5	S101-1033 ②	Right Side
5	S101-1013 ③	Right Side
6	105-1346	Side Filter Angle
6	105-1346 ②	Side Filter Angle
6	105-1370 ③	Side Filter Angle
7	553-660-* ①	Hood Mounting Door
7	553-712 ②	Hood Mounting Door
7	553-703 ③	Hood Mounting Door
8	S107-346-* ①	Hood Top
8	S107-354 ②	Hood Top
8	S107-353 ③	Hood Top
9	553-613	Filter Door
9	553-632 ②	Filter Door
9	553-636 ③	Filter Door
10	S101-873-* ①	Left Side
10	S101-997 ②	Left Side
10	S101-882 ③	Left Side
	920-0375	Complete Hood Assembly - Beige
	920-0376	Complete Hood Assembly - White
	920-0377	Complete Hood Assembly - Buckeye Gray
	920-0422	Complete Hood Assembly - Stainless Steel
	920-0411	Complete Hood Assembly - Aluminum

① Exterior cabinet parts are manufactured with various paint color options. To ensure the proper paint color is received, reference the following codes:

Beige -X Buckeye Gray -4 White -1

② Exterior cabinet parts are manufactured from stainless steel Code "S"

③ Exterior cabinet parts are manufactured from aluminum Code "A"

FREECOOLING DAMPER MOTOR

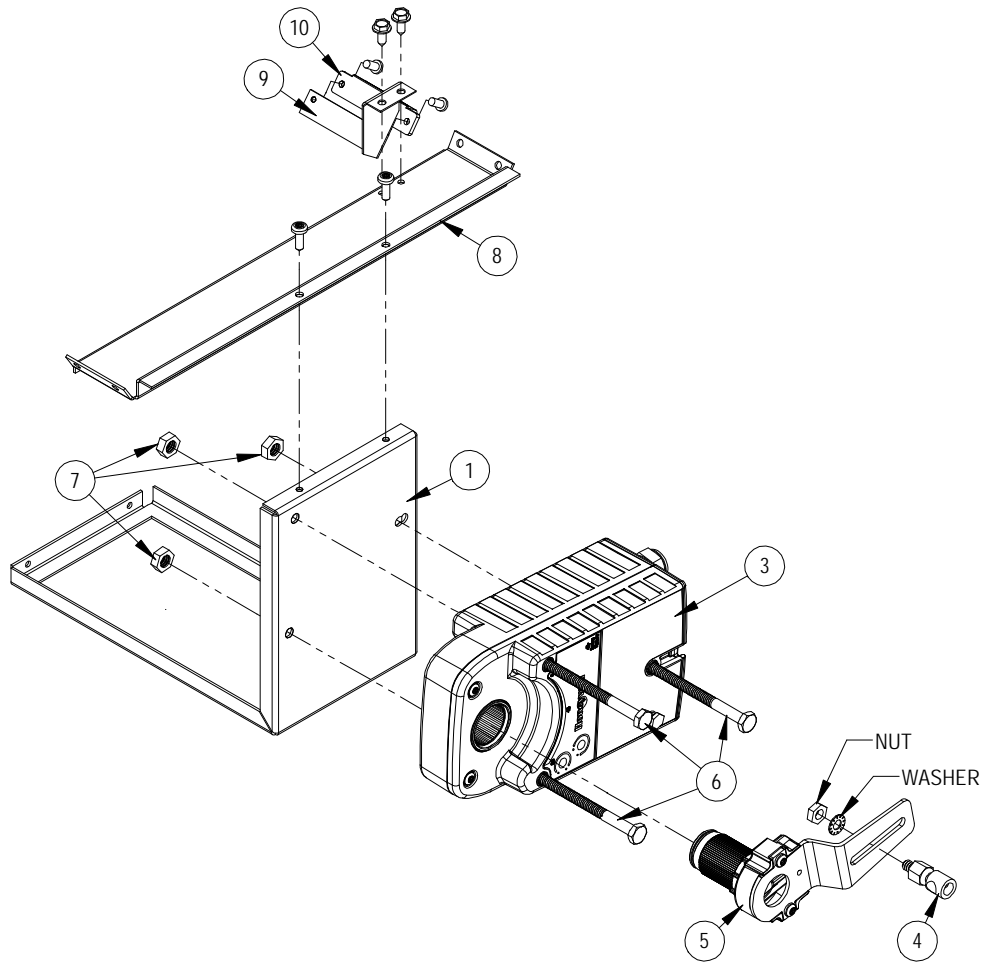

SEXP-879

Dwg. No.	Part Number	Description
1	141-466	Actuator Support Plate
3	8602-067	Direct Coupled Actuator
4	8602-008	Ball Joint
5	8602-068	Belimo Actuator Crank Arm 1/2"
6	1012-174	1/4" - 20x3 - 1/4 Hex Cap Screws
7	1012-201	1/4-20 Steel Keps Hex Nut Zinc
8	141-464	Actuator Support Bar
9	113-655	Blade Switch Bracket
10	8406-150	Lever Switch SPDT Sealed Pilot Duty
11	1012-178	4-40 x 5/8" Phillips Pan Head Machine Screw, Zinc Plated
12	1012-231	4-40 Steel Keps Hex Nut Zinc
NS	910-2014	Outdoor Temperature Sensor