

---

# REPLACEMENT PARTS MANUAL

---

## Wall Mounted Packaged Air Conditioner

Models:

W18AB-A W24AB-A  
W24AB-B  
W24AB-C  
W24AB-D  
W24AB-F

---

### General Notes

- Revised and/or additional pages may be issued from time to time.
- A complete and current manual consists of pages shown in the following contents section.

### Important

- Contact the installing and/or local Bard distributor for all parts requirements. Make sure to have the complete model and serial number available from the unit rating plates.

### Contents

<u>Description</u>	<u>Page</u>
Cabinet Components	
♦ Exploded View .....	2
♦ Usage List .....	3
Functional Components	
♦ Exploded View .....	4
♦ Usage List .....	5
Control Panel	
♦ Layout View .....	6
♦ Usage List .....	7
Blower Assembly	
♦ Exploded View .....	8
♦ Usage List .....	8



Bard Manufacturing Company, Inc.  
Bryan, Ohio 43506  
www.bardhvac.com

Manual: 2110-1447F  
Supersedes: 2110-1447E  
Date: 10-28-20



# CABINET COMPONENTS

Dwg No.	Part Number	Description	W18AB-A	W24AB-A	W24AB-B	W24AB-D	W24AB-C	W24AB-F
1	113-141-* ①	Top Rain Flashing	X	X	X	X	X	X
1	113-361 ②	Top Rain Flashing	X	X	X	X	X	X
1	113-141-4 ③	Top Rain Flashing	X	X	X	X	X	X
2	S507-311-* ①	Top	X	X	X	X	X	X
2	S507-318-* ③	Top	X	X	X	X	X	X
2	S507-317 ②	Top	X	X	X	X	X	X
3	S123-126	Drain Pan	X	X	X	X	X	X
3	S123-140 ②③	Drain Pan	X	X	X	X	X	X
4	S509-445	Upper Back	X	X	X	X	X	X
4	S509-447 ③	Upper Back	X	X	X	X	X	X
4	S509-449 ②	Upper Back	X	X	X	X	X	X
5	105-1302	Grommet Retainer	X	X	X	X	X	X
6	S501-933-* ①	Right Side	X	X	X	X	X	X
6	S501-994 ②	Right Side	X	X	X	X	X	X
6	S501-937 ③	Right Side	X	X	X	X	X	X
7	S543-175-* ①	Right Side Cover Plate (Outer)	X	X	X	X	X	X
7	S543-185 ②	Right Side Cover Plate (Outer)	X	X	X	X	X	X
7	S543-184 ③	Right Side Cover Plate (Outer)	X	X	X	X	X	X
8	113X480	Filter Bracket	2	2	2	2	2	2
9	137-259	Fill Plate	X	X	X	X	X	X
10	S132-104	Control Panel Cover (Inner)	X	X	X	X		
10	S132-172	Control Panel Cover (Inner)					X	X
11	113-140	Bottom Mounting Bracket	X	X	X	X	X	X
12	S153-218 ①	Disconnect Access Door	X	X	X	X	X	X
12	S153-405 ②	Disconnect Access Door	X	X	X	X	X	X
12	S153-387 ③	Disconnect Access Door	X	X	X	X	X	X
13	S533-228-* ①	Control Panel Cover (Outer)	X	X	X	X	X	X
13	S533-235 ②	Control Panel Cover (Outer)	X	X	X	X	X	X
13	S533-236 ③	Control Panel Cover (Outer)	X	X	X	X	X	X
14	118-124-* ①	Side Grille	2	2	2	2	2	2
14	118-140 ②	Side Grille	2	2	2	2	2	2
14	118-141 ③	Side Grille	2	2	2	2	2	2
15	Control Panel Assembly	See Control Panel Assy. Drawing & Parts List Assy.	X	X	X	X	X	X
16	105-1392	Close Off Angle	X	X	X	X	X	X
17	S536-176	Cond. Partition Block Off Plate	X	X	X	X	X	X
17	S536-878 ②	Cond. Partition Block Off Plate	X	X	X	X	X	X
18	S127-467	Lower Base	X	X	X	X	X	X
18	S127-534 ②	Lower Base	X	X	X	X	X	X
19	125-080	Fan Shroud	X	X	X	X	X	X
19	125-082 ②	Fan Shroud	X	X	X	X	X	X
20	S521X528	Condenser Partition	X	X	X	X	X	X
20	S521-553 ②	Condenser Partition	X	X	X	X	X	X
21	FAD-NE2	Fresh Air Damper Assembly	X	X	X	X	X	X
22	118-101-* ①	Condenser Grille	X	X	X	X	X	X
22	118-106 ②	Condenser Grille	X	X	X	X	X	X
22	118-144 ③	Condenser Grille	X	X	X	X	X	X
23	S553-537-* ①	Vent Option Door	X	X	X	X	X	X
23	S553-547 ②	Vent Option Door	X	X	X	X	X	X
23	S553-548 ③	Vent Option Door	X	X	X	X	X	X
23	S553-539-* ①	Vent Option Door with ERV	X	X	X	X	X	X
23	S553-555 ②	Vent Option Door with ERV	X	X	X	X	X	X
23	S553-556 ③	Vent Option Door with ERV	X	X	X	X	X	X
23	S553-666-* ①	Vent Option Door with CRV or ECON-S	X	X	X	X	X	X
23	S553-692 ③	Vent Option Door with CRV or ECON-S	X	X	X	X	X	X
23	S553-693 ②	Vent Option Door with CRV or ECON-S	X	X	X	X	X	X
24	S553-538-* ①	Filter Door	X	X	X	X	X	X
24	S553-552-* ③	Filter Door	X	X	X	X	X	X
24	S553-551 ②	Filter Door	X	X	X	X	X	X
25	S514-240-* ①	Upper Front	X	X	X	X	X	X
25	S514-237-* ③	Upper Front	X	X	X	X	X	X
25	S514-236 ②	Upper Front	X	X	X	X	X	X
26	121X480	Blower Partition	X	X	X	X	X	X
27	105X850	Side Support	X	X	X	X	X	X
28	137-694	Bottom Evaporator Fill	X	X	X	X	X	X
29	S501-934-* ①	Left Side	X	X	X	X	X	X
29	S501-995 ②	Left Side	X	X	X	X	X	X
29	S501-940 ③	Left Side	X	X	X	X	X	X
30	147-044	Evaporator Support	X	X	X	X	X	X
31	S111X032	Outlet Air Frame Assembly	X	X	X	X	X	X
32	135X127	Heat Shield	X	X	X	X	X	X
33	109-444	Lower Back	X	X	X	X	X	X
33	109-446 ③	Lower Back	X	X	X	X	X	X
33	109-448 ②	Lower Back	X	X	X	X	X	X
NS	5252-033	Bard Nameplate	X	X	X	X	X	X

① Exterior cabinet parts are manufactured with various paint color options. To ensure the proper paint color is received, include the complete model and serial number of the unit for which cabinet parts are being ordered.  
 ② Exterior cabinet parts are manufactured from stainless steel Code "S"  
 ③ Exterior cabinet parts are manufactured from aluminum Code "A"

# FUNCTIONAL COMPONENTS

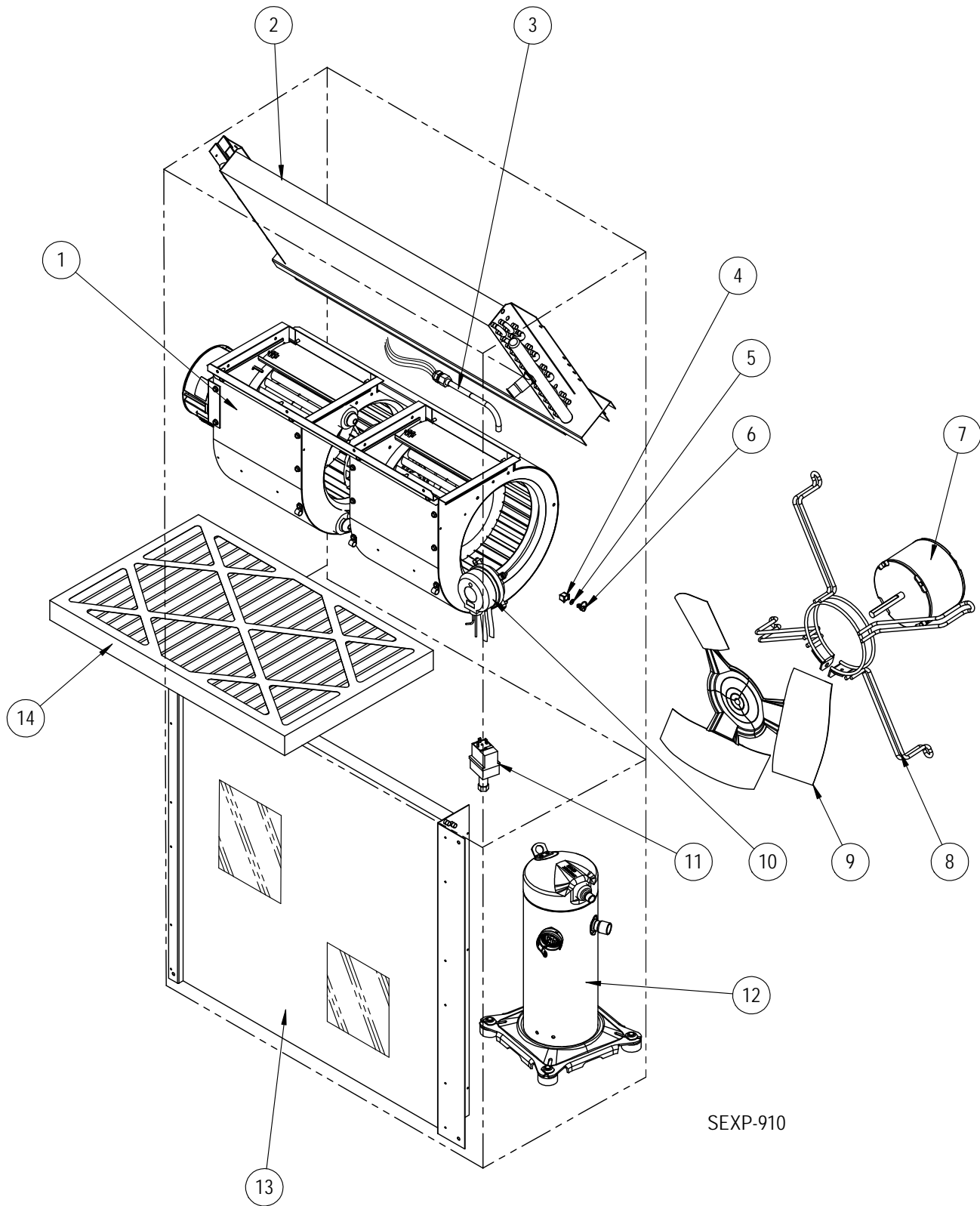

# FUNCTIONAL COMPONENTS

Dwg No.	Part Number	Description	W18AB-A	W24AB-A	W24AB-B	W24AB-C	W24AB-D	W24AB-F
1	S900-358-002	Blower Assembly		X	X		X	X
1	S900-359-001	Blower Assembly				X		
1	S900-358-001	Blower Assembly	X					
2	917-0381BX	Evaporator Coil with Distributor Assembly	X					
2	917-0382BX	Evaporator Coil – Coated with Distributor Assembly	X					
2	917-0353BX	Evaporator Coil with Distributor Assembly		X	X	X	X	X
2	917-0354BX	Evaporator Coil – Coated with Distributor Assembly		X	X	X	X	X
3	800-0458	Distributor Assembly	X					
3	800-0481	Distributor Assembly		X	X	X	X	X
4	1171-023	1/4" Receptacle	X	X	X	X	X	X
5	1171-024	1/4" Turn Retainer	X	X	X	X	X	X
6	1171-022	1/4" Turn Fastener	X	X	X	X	X	X
7	8103-028	Condenser Motor	X	X	X		X	X
7	8103-030	Condenser Motor				X		
8	8200-001	Fan Motor Mount	X	X	X	X	X	X
8	8200-050 ①	Stainless Steel Fan Motor Mount	X	X	X	X	X	X
9	5151-033	Fan Blade	X	X	X		X	X
9	5151C003 ①	Coated Fan Blade	X	X	X		X	X
9	5151-046	Fan Blade				X		
9	5151C046 ①	Coated Fan Blade				X		
10	CMC-31	Dirty Filter Switch Kit	X	X	X	X	X	X
11	CMA-37	Modulating Low Ambient Control (Screw On) ②	X	X	X		X	X
11	CMA-38	460V Modulating Low Ambient Control ②				X		
12	8000-433	Compressor	X					
12	8000-434	Compressor		X				
12	8000-435	Compressor			X			
12	8000-436	Compressor				X		X
12	8000-437	Compressor					X	
13	5051-205BX	Condenser Coil	X					
13	5054-205BX	Condenser Coil – Coated	X					
13	5051-204BX	Condenser Coil		X	X	X	X	X
13	5054-204BX	Condenser Coil – Coated		X	X	X	X	X
14	7004-011	Air Filter 1" Throw-Away (16x25x1)	X	X	X	X	X	X
14	7003-032	Air Filter 1" Washable ② (16x25x1)	X	X	X	X	X	X
14	7004-025	Air Filter 2" Pleated ② (16x25x2)	X	X	X	X	X	X
14	7004-059	Air Filter 2" Pleated – MERV 11 ② (16x25x2)	X	X	X	X	X	X
14	7004-061	Air Filter 2" Pleated – MERV 13 ② (16x25x2)	X	X	X	X	X	X
NS	8406-142	High Pressure Switch (Screw On)	X	X	X	X	X	X
NS	8406-140	Low Pressure Switch (Screw On)	X	X	X	X	X	X
NS	5201-021	Filter Drier	X	X	X	X	X	X
NS	5451-024	Tubing Isolation Grommet	X	X	X	X	X	X
NS	6031-009	Coremax Value Core	X	X	X	X	X	X
NS	1171-028	Filter Door Clip	2	2	2	2	2	2
NS	1171-057	Filter Door Screw	2	2	2	2	2	2
NS	1171-027	Filter Door Screw Retainer	2	2	2	2	2	2
NS	CMC-29	Freeze Thermostat Kit	X	X	X	X	X	X

NS – Not Shown

① – Used with stainless steel cabinet option

② – Optional on these models

# CONTROL PANEL

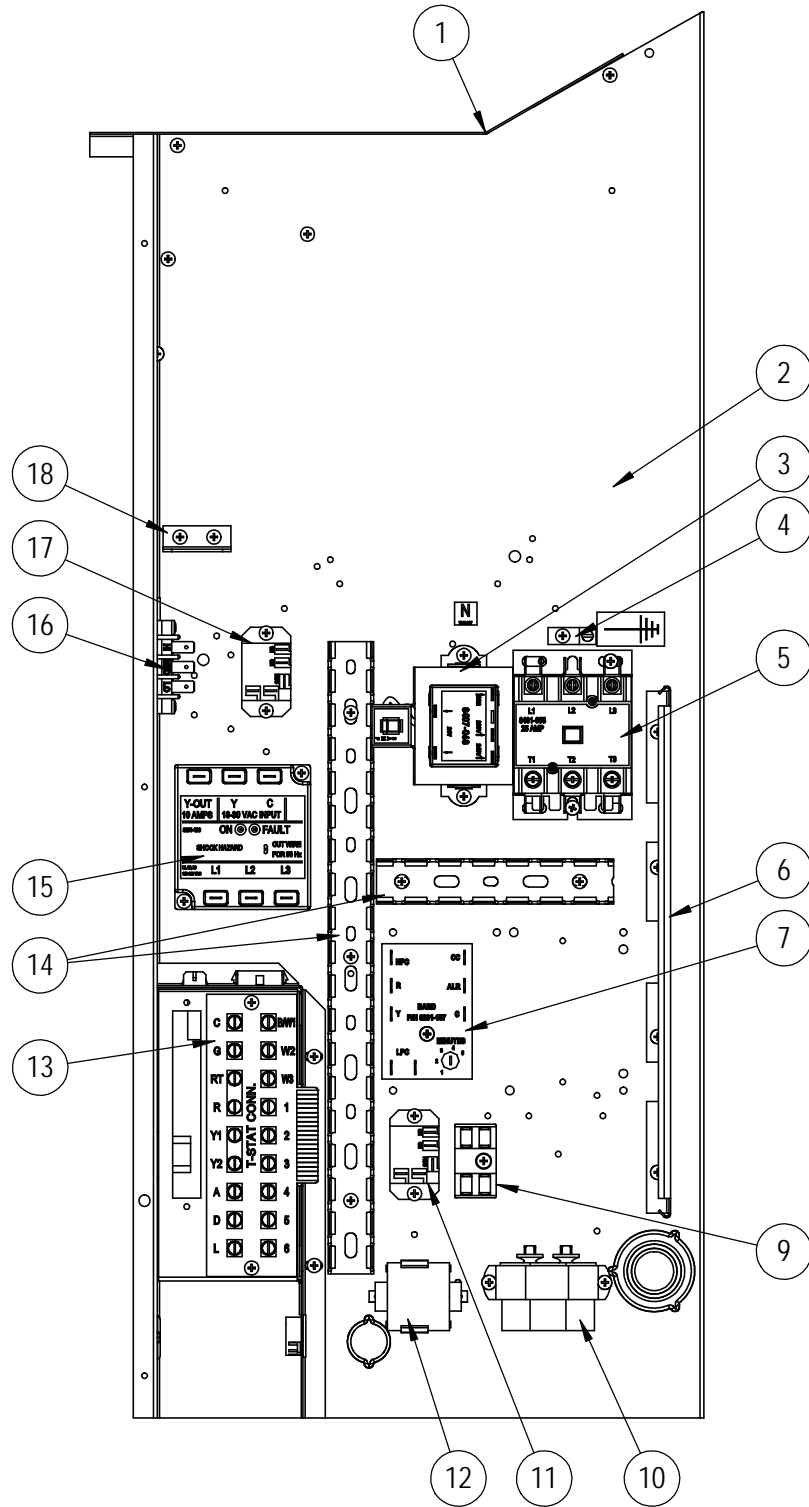

SEXP-908

# CONTROL PANEL

Dwg No.	Part Number	Description	W18AB-A	W24AB-A	W24AB-B	W24AB-C	W24AB-D	W24AB-F
1	117X137	Control Panel Top	X	X	X	X	X	X
2	117X407	Control Panel	X	X	X	X	X	X
3	8407-068	Transformer	X	X	X		X	X
3	8407-069	Transformer				X		
4	8611-006	Ground Terminal	X	X	X	X	X	X
5	8401-033	Compressor Contactor	X	X			X	
5	8401-035	Compressor Contactor			X	X		X
6	135-122	Wire Shield	X	X	X	X	X	X
7	8201-164	Compressor Control Module	X	X	X	X	X	X
9	8607-017	Terminal Block (Optional)	X	X	X	X	X	X
10	8552-047	Compressor Capacitor	X					
10	8552-050	Compressor Capacitor		X			X	
10	8552-002	Outdoor Motor Capacitor			X	X		X
11	8201-130	Alarm Relay (Optional)	X	X	X	X	X	X
12	8551-004	Start Device (PTCR) (Optional)	X	X			X	
13	8607-063	Low Voltage Terminal Strip	X	X	X	X	X	X
14	8611-140-1400	Cable Duct – 14" Piece	X	X	X	X	X	X
14	8611-140-0500	Cable Duct – 5" Piece	X	X	X	X	X	X
15	8201-126	Phase Monitor			X	X		X
16	8607-042	Blower Speed Terminal	X	X	X	X	X	X
17	8201-130	Blower Control Relay	X	X	X	X	X	X
18	141-188	Plug Support Bracket	X	X	X	X	X	X
NS	3000-1598	Blower Power Plug	X	X	X	X	X	X
NS	3000-1607	Blower Speed Plug	X					
NS	3000-1599	Blower Speed Plug		X	X	X	X	X
NS	3000-1524	Vent Jumper Plug	X	X	X	X	X	X
NS	8615-035	Circuit Breaker 20A 2 Pole (Opt.) ①	X				X	
NS	8615-036	Circuit Breaker 25A 2 Pole (Opt.) ①		X				
NS	S8615-067	Toggle Disconnect (Optional) ①				X		X
NS	8615-056	Circuit Breaker 15A 3 Pole (Opt.) ①			X			
NS	8607-013	Terminal Block 2 Pole						X
NS	113-601	Terminal Block Bracket						X
NS	4095-197	Wiring Diagram	X					
NS	4095-196	Wiring Diagram		X			X	
NS	4095-296	Wiring Diagram			X			
NS	4095-381	Wiring Diagram				X		
NS	4095-640	Wiring Diagram						X
NS	3000-1224	Compressor Plug/Harness	X	X			X	
NS	3000-1231	Compressor Plug/Harness			X	X		X
NS	3003-047	Control Panel Harness		X			X	
NS	3003-048	Control Panel Harness			X	X		
NS	3003-049	Control Panel Harness						X
NS	3003-052	Control Panel Harness	X					
NS	3000-1608	Low Voltage Terminal Block Harness	X	X	X	X	X	X
NS	S910-2047	Complete Low Voltage Box Assembly (Sheet Metal, LVTS & Wire Harness)	X	X	X	X	X	X

NS = Not Shown

① Circuit breakers listed are for units without electric heat, "OZ" models. See heater replacement parts manual for units with electric heat.

# BLOWER ASSEMBLY

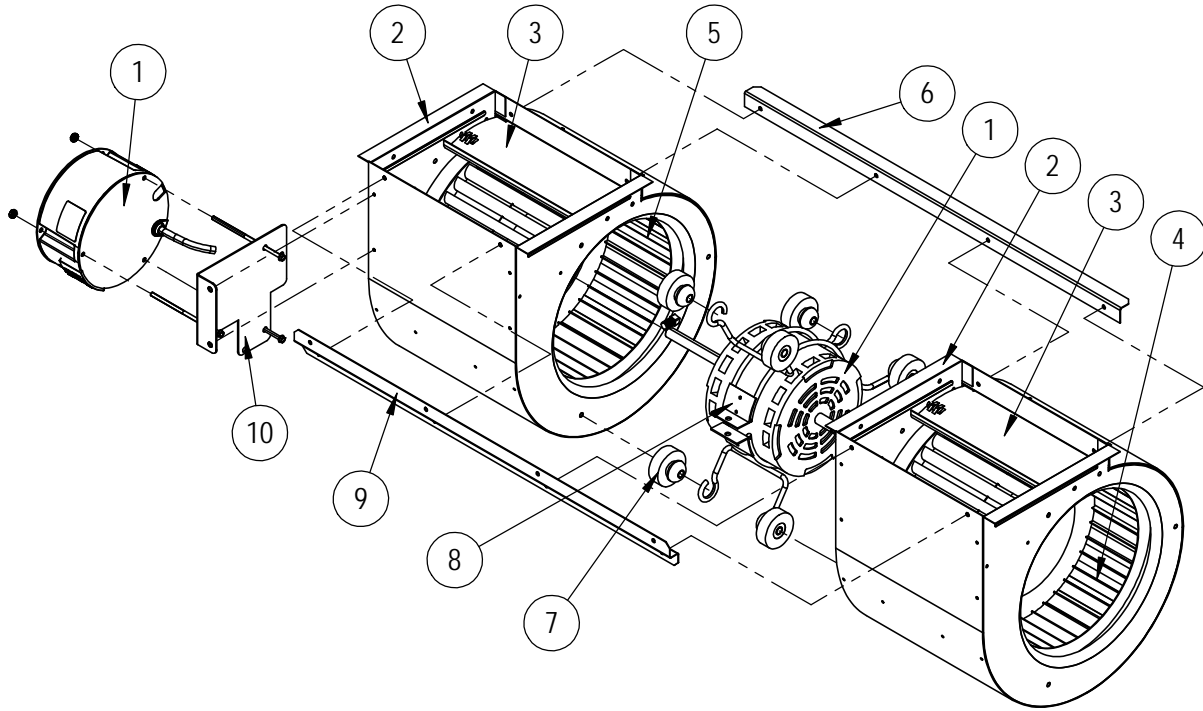

SEXP-909

Dwg No.	Part Number	Description	S900-358-001	S900-358-002	S900-359-001
1	S8105-064-0147	Blower Motor & Control (230/208V)	X		
1	S8105-064-0148	Blower Motor & Control (230/208V)		X	
1	S8105-065-0149	Blower Motor & Control (460V)			X
1	C8105-064-0147	Programmed Control Only (230/208V)	0		
1	C8105-064-0148	Programmed Control Only (230/208V)		0	
1	C8105-065-0149	Programmed Control Only (460V)			0
2	151-115	Housing	2	2	2
3	144-183	Cutoff	X	X	X
4	5152-092	Wheel 9-6 CW	X	X	X
5	5152-093	Wheel 9-6 CCW	X	X	X
6	105-1061	Back Brace	X	X	X
7	5451-011	Grommets	6	6	6
8	8200-031	Motor Mount	X	X	X
9	103-435	Front Brace	X	X	X
10	113-721	Motor Control Bracket	X	X	