REPLACEMENT PARTS MANUAL

WALL MOUNTED PACKAGE AIR CONDITIONER

Models:

W48AAMA W60ABMA W72ABMA
W48AAMB W60ABMB W72ABMB
W48AAMC W60ABMC W72ABMC

Contents

<u>Description</u>	<u>Page</u>
Cabinet Components	
♦ Exploded View	2
♦ Usage List	3
♦ Usage List	4
Functional Components	
♦ Exploded View	6
♦ Usage List	7
♦ Usage List	8
Control Panel	
♦ Layout View	10
♦ Usage List	11
♦ Usage List	12
♦ Usage List	13
Blower Assembly	
♦ Exploded View	14
♦ Usage List	14
♦ Exploded View	15
♦ Usage List	15

General Notes

- Revised and/or additional pages may be issued from time to time.
- A complete and current manual consists of pages shown in the following contents section.

Important

- Contact the installing and/or local Bard distributor for all parts requirements. Make sure to have the complete model and serial number available from the unit rating plates.



Bard Manufacturing Company, Inc.
Bryan, Ohio 43506
www.bardhvac.com

Manual: 2110-1445D
Supersedes: 2110-1445C
Date: 5-15-19

CABINET COMPONENTS

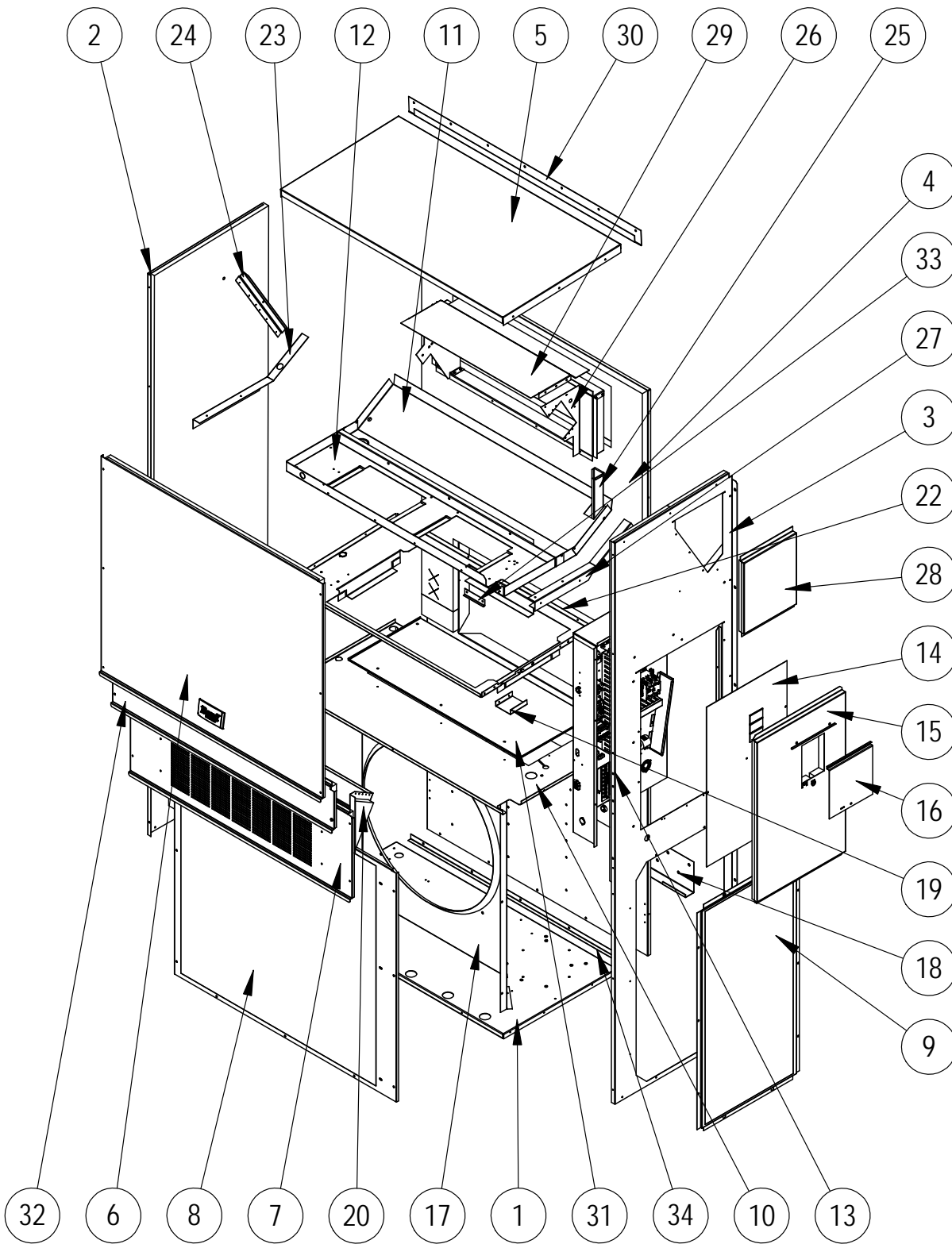

This drawing is referenced in tables on pages 3 and 4

SEXP-792

CABINET COMPONENTS

Dwg No.	Part Number	Description	W48AAMA	W48AAMB	W48AAMC
1	S127-425	Lower Base	X	X	X
1	S127-541 ③	Lower Base	X	X	X
2	S501-686-* ①	Left Side	X	X	X
2	S501-699 ②	Left Side	X	X	X
2	S501-1004 ③	Left Side	X	X	X
3	S501-840-* ①	Right Side	X	X	X
3	S501-924 ②	Right Side	X	X	X
3	S501-1003 ③	Right Side	X	X	X
4	S508-098	Back	X	X	X
4	S508-275 ②	Back	X	X	X
4	S508-395 ③	Back	X	X	X
5	S507-307-* ①	Top	X	X	X
5	S507-309 ②	Top	X	X	X
5	S507-310 ③	Top	X	X	X
6	S515-230-* ①	Upper Front	X	X	X
6	S514-231 ②	Upper Front	X	X	X
6	S514-232 ③	Upper Front	X	X	X
7	S553-522-* ①	Vent Option Door	X	X	X
7	S553-529-* ①	Vent Option Door with ERV	X	X	X
7	S553-525 ②	Vent Option Door	X	X	X
7	S553-527 ③	Vent Option Door	X	X	X
8	118-048-* ①	Condenser Grille	X	X	X
8	118-064 ②	Condenser Grille	X	X	X
8	118-072 ③	Condenser Grille	X	X	X
9	118-057-* ①	Side Grille	2	2	2
9	118-063 ②	Side Grille	2	2	2
9	118-073 ③	Side Grille	2	2	2
10	S521X503	Condenser Partition	X	X	X
10	S521-559 ③	Condenser Partition	X	X	X
11	S123-122	Drain Pan	X	X	X
11	S123-125 ②③	Drain Pan	X	X	X
12	121X463	Blower Partition	X	X	X
13	Control Panel Assy.	See Control Panel Assy. Drawing & Parts List	X	X	X
14	S132-277	Control Panel Cover (Inner)	X	X	
14	S132-278	Control Panel Cover (Inner)			X
15	S533-279-* ①	Control Panel Cover (Outer)	X	X	X
15	S533-273 ②	Control Panel Cover (Outer)	X	X	X
15	S533-274 ③	Control Panel Cover (Outer)	X	X	X
16	S153-218-* ①	Disconnect Access Door	X	X	X
16	S153-387 ②	Disconnect Access Door	X	X	X
16	S153-405 ③	Disconnect Access Door	X	X	X
17	125-024	Fan Shroud	X	X	X
17	125-058 ③	Fan Shroud	X	X	X
18	113-140	Bottom Mounting Bracket	X	X	X
19	137-209	Fill	X	X	X
20	BFAD-5	Fresh Air Damper Assembly	X	X	X
22	131X099	Filter Tray	X	X	X
23	105X877	Left Side Support	X	X	X
24	147-046	Left Evaporator Support	X	X	X
25	135-377	Raceway	2	2	2
26	S111X034	Outlet Air Frame Assembly	X	X	X
27	105X878	Right Side Support	X	X	X
28	S543-172-* ①	Right Side Cover Plate (Outer)	X	X	X
28	S543-176 ②	Right Side Cover Plate (Outer)	X	X	X
28	S543-177 ③	Right Side Cover Plate (Outer)	X	X	X
29	135-129	Heat Shield	X	X	X
30	113-150-* ①	Top Rain Flashing	X	X	X
30	113-359 ③	Top Rain Flashing	X	X	X
31	S536-804	Cond. Partition Block Off Plate	X	X	X
31	S536-881 ③	Cond. Partition Block Off Plate	X	X	X
32	S553-521-* ①	Filter Door Assembly	X	X	X
32	S553-526 ②	Filter Door Assembly	X	X	X
32	S553-528 ③	Filter Door Assembly	X	X	X
33	105-1302	Grommet Retainer	X	X	X
34	105-1324	Close Off Angle	X	X	X

- ① Exterior cabinet parts are manufactured with various paint color options. To ensure the proper paint color is received, please reference the following codes: Beige -X, White -1, Buckeye Gray -4, Desert Brown -5, Dark Bronze -8
 ② Exterior cabinet parts are manufactured from aluminum Code "A"
 ③ Exterior cabinet parts are manufactured from stainless steel Code "S"

CABINET COMPONENTS

Dwg No.	Part Number	Description	W60ABMA	W60ABMB	W60ABDC	W72ABMA	W72ABMB	W72ABMC
1	127-425	Lower Base	X	X	X	X	X	X
1	127-541 ③	Lower Base	X	X	X	X	X	X
2	S501-733-* ①	Left Side	X	X	X	X	X	X
2	S501-828 ②	Left Side	X	X	X	X	X	X
2	S501-1010 ③	Left Side	X	X	X	X	X	X
3	S501-841-* ①	Right Side	X	X	X	X	X	X
3	S501-928 ②	Right Side	X	X	X	X	X	X
3	S501-1011 ③	Right Side	X	X	X	X	X	X
4	S508-251	Back	X	X	X	X	X	X
4	S508-252 ②	Back	X	X	X	X	X	X
4	S508-396 ③	Back	X	X	X	X	X	X
5	S507-307-* ①	Top	X	X	X	X	X	X
5	S507-309 ②	Top	X	X	X	X	X	X
5	S507-310 ③	Top	X	X	X	X	X	X
6	S515-246-* ①	Upper Front	X	X	X	X	X	X
6	S514-280 ②	Upper Front	X	X	X	X	X	X
6	S514-253 ③	Upper Front	X	X	X	X	X	X
7	S553-522-* ①	Vent Option Door	X	X	X	X	X	X
7	S553-529-* ①	Vent Option Door with ERV	X	X	X	X	X	X
7	S553-525 ②	Vent Option Door	X	X	X	X	X	X
7	S553-527 ③	Vent Option Door	X	X	X	X	X	X
8	118-085-* ①	Condenser Grille	X	X	X	X	X	X
8	118-087 ②	Condenser Grille	X	X	X	X	X	X
8	118-089 ③	Condenser Grille	X	X	X	X	X	X
9	118-086-* ①	Side Grille	2	2	2	2	2	2
9	118-088 ②	Side Grille	2	2	2	2	2	2
9	118-090 ③	Side Grille	2	2	2	2	2	2
10	S521X503	Condenser Partition	X	X	X	X	X	X
10	S521-559 ③	Condenser Partition	X	X	X	X	X	X
11	S123-122	Drain Pan	X	X	X	X	X	X
11	S123-125 ②③	Drain Pan	X	X	X	X	X	X
12	121X463	Blower Partition	X	X	X	X	X	X
13	Control Panel Assy.	See Control Panel Assy. Drawing & Parts List	X	X	X	X	X	X
14	S132-277	Control Panel Cover (Inner)	X	X		X	X	
14	S132-278	Control Panel Cover (Inner)			X			X
15	S533-279-* ①	Control Panel Cover (Outer)	X	X	X	X	X	X
15	S533-273 ②	Control Panel Cover (Outer)	X	X	X	X	X	X
15	S533-274 ③	Control Panel Cover (Outer)	X	X	X	X	X	X
16	S153-218-* ①	Disconnect Access Door	X	X	X	X	X	X
16	S153-387 ②	Disconnect Access Door	X	X	X	X	X	X
16	S153-405 ③	Disconnect Access Door	X	X	X	X	X	X
17	125-070	Fan Shroud	X	X	X			
17	125-079 ③	Fan Shroud	X	X		X	X	X
17	125-084	Fan Shroud				X	X	X
18	113-140	Bottom Mounting Bracket	X	X	X	X	X	X
19	137-209	Fill	X	X	X	X	X	X
20	BFAD-5	Fresh Air Damper Assembly	X	X	X	X	X	X
22	131X099	Filter Tray	X	X	X	X	X	X
23	105X877	Left Side Support	X	X	X	X	X	X
24	147-046	Left Evaporator Support	X	X	X	X	X	X
25	135-377	Raceway	2	2	2	2	2	2
26	S111X034	Outlet Air Frame Assembly	X	X	X	X	X	X
27	105X878	Right Side Support	X	X	X	X	X	X
28	S543-172-* ①	Right Side Cover Plate (Outer)	X	X	X	X	X	X
28	S543-176 ②	Right Side Cover Plate (Outer)	X	X	X	X	X	X
28	S543-177 ③	Right Side Cover Plate (Outer)	X	X	X	X	X	X
29	135-129	Heat Shield	X	X	X	X	X	X
30	113-150-* ①	Top Rain Flashing	X	X	X	X	X	X
30	113-359 ③	Top Rain Flashing	X	X	X	X	X	X
31	S536-804	Cond. Partition Block Off Plate	X	X	X	X	X	X
31	S536-881 ③	Cond. Partition Block Off Plate	X	X	X	X	X	X
32	S553-521-* ①	Filter Door Assembly	X	X	X	X	X	X
32	S553-526 ②	Filter Door Assembly	X	X	X	X	X	X
32	S553-528 ③	Filter Door Assembly	X	X	X	X	X	X
33	105-1302	Grommet Retainer	X	X	X	X	X	X
34	105-1324	Close Off Angle	X	X	X	X	X	X

① Exterior cabinet parts are manufactured with various paint color options. To ensure the proper paint color is received, please reference the following codes: Beige -X, White -1, Buckeye Gray -4, Desert Brown -5, Dark Bronze -8

② Exterior cabinet parts are manufactured from aluminum code "A"

③ Exterior cabinet parts are manufactured from stainless steel code "S"

This page intentionally left blank

FUNCTIONAL COMPONENTS

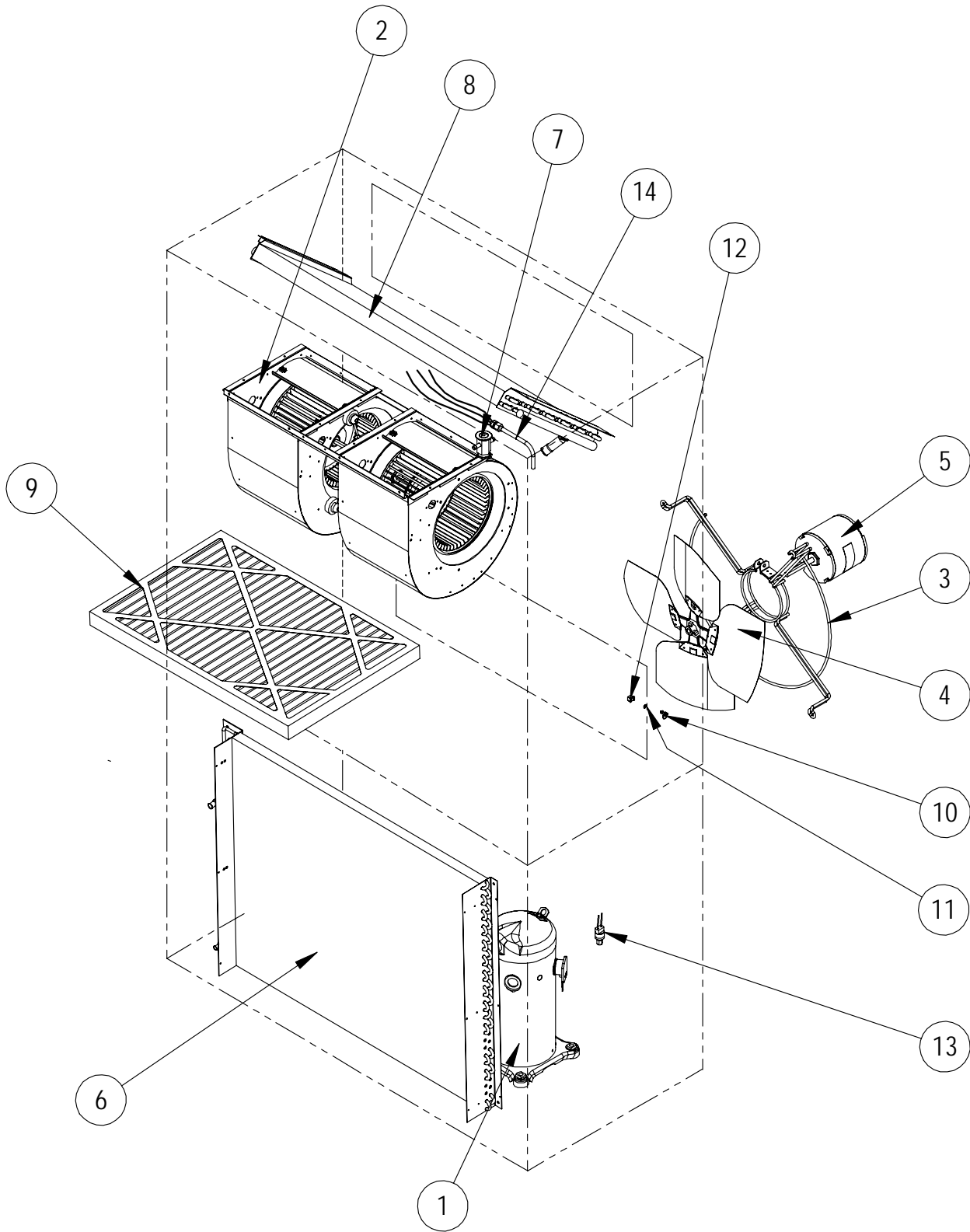

SEXP-177 A

This drawing is referenced in tables on pages 7 and 8

FUNCTIONAL COMPONENTS

Dwg No.	Part Number	Description	W48AAMA	W48AAMB	W48AAMC	W60ABMA	W60ABMB	W60ABMC
1	8000-343	Compressor	X					
1	8000-344	Compressor		X				
1	8000-345	Compressor			X			
1	8000-324	Compressor				X		
1	8000-325	Compressor					X	
1	8000-326	Compressor						X
2	S900-320	Blower Assembly	X	X				
2	S900-321	Blower Assembly			X			
2	S900-185	Blower Assembly				X	X	
2	S900-186	Blower Assembly						X
3	8200-004	Fan Motor Mount	X	X	X	X	X	X
3	8200-051 ①	Stainless Steel Fan Motor Mount	X	X	X	X	X	X
4	5151-060	Fan Blade	X	X	X	X	X	X
4	5151C060 ①	Coated Fan Blade	X	X	X	X	X	X
5	8105-071	Condenser Motor			X			X
5	8105-068	Condenser Motor	X	X		X	X	
5	8105-039	Condenser Motor						
6	5051-199BX	Condenser Coil	X	X	X			
6	5054-199BX	Condenser Coil - Coated	X	X	X			
6	5051-198BX	Condenser Coil				X	X	X
6	5054-198BX	Condenser Coil - Coated				X	X	X
7	5651-223	Expansion Valve	X	X	X			
7	5651-237	Expansion Valve				X	X	X
8	917-0261BX	Evaporator Coil	X	X	X			
8	917-0270BX	Evaporator Coil - Coated	X	X	X			
8	917-0259BX	Evaporator Coil				X	X	X
8	917-0267BX	Evaporator Coil - Coated				X	X	X
9	7004-016	Air Filter 1" Throw-Away (20x30x1)	X	X	X	X	X	X
9	7003-030	Air Filter 1" Washable (20x30x1)	X	X	X	X	X	X
9	7004-027	Air Filter 2" Pleated (20x30x2)	X	X	X	X	X	X
10	1171-022	1/4 Turn Fastener	X	X	X	X	X	X
11	1171-024	1/4 Turn Retainer	X	X	X	X	X	X
12	1171-023	1/4 Receptacle	X	X	X	X	X	X
13	8406-142	High Pressure Switch	X	X	X	X	X	X
13	8406-140	Low Pressure Switch	X	X	X	X	X	X
14	800-0424	Distributor Assembly	X	X	X			
14	800-0455	Distributor Assembly				X	X	X
NS	5201-022	Filter Drier	X	X	X	X	X	X
NS	5650-042	Rev. Valve Solenoid, Red Casing (Ranco)	X	X	X	X	X	X
NS	5650-046	Rev. Valve Solenoid, Black Casing (San Hua)	X	X	X	X	X	X
NS	5650-051	Dehum. Valve 4-Pipe 1/2 x 1/2 with 24V Solenoid Coil	X	X	X	X	X	X
NS	CMA-28	Low Ambient Control (Flare) ②	X	X	X	X	X	X
NS	5651-219	Check Valve	2	2	2	2	2	2
NS	5451-024	Tubing Isolation Grommet	2	2	2	2	2	2
NS	6031-009	Coremax Valve Core	2	2	2	2	2	2
NS	8605-017	Compressor Crankcase Heater	X	X		X	X	
NS	8605-018	Compressor Crankcase Heater			X			X
NS	1171-028	Filter Door Clip	2	2	2	2	2	2
NS	1171-057	Filter Door Screw	2	2	2	2	2	2
NS	1171-027	Filter Door Screw Retainer	2	2	2	2	2	2

NS – Not Shown

① – Used with stainless steel cabinet option

② – Optional on these models

FUNCTIONAL COMPONENTS

Dwg No.	Part Number	Description	W72ABMA	W72ABMB	W72ABMC
1	8000-403	Compressor	X		
1	8000-404	Compressor		X	
1	8000-405	Compressor			X
2	S900-348-001	Blower Assembly	X	X	
2	S900-349-001	Blower Assembly			X
3	8200-049	Fan Motor Mount	X	X	X
3	8200-052 ①	Stainless Steel Fan Motor Mount	X	X	X
4	5151-062	Fan Blade	X	X	X
4	5151C062 ①	Coated Fan Blade	X	X	X
5	8106-070	Condenser Motor	X	X	
5	8106-071	Condenser Motor			X
6	5051-197BX	Condenser Coil	X	X	X
6	5054-197BX	Condenser Coil - Coated	X	X	X
7	905-0729	EEV Valve Assembly	X	X	X
8	917-0259BX	Evaporator Coil	X	X	X
8	917-0267BX	Evaporator Coil - Coated	X	X	X
9	7004-016	Air Filter 1" Throw-Away (20x30x1)	X	X	X
9	7003-030	Air Filter 1" Washable (20x30x1)	X	X	X
9	7004-027	Air Filter 2" Pleated (20x30x2)	X	X	X
10	1171-022	1/4 Turn Fastener	X	X	X
11	1171-024	1/4 Turn Retainer	X	X	X
12	1171-023	1/4 Receptacle	X	X	X
13	8406-153	Low Pressure Transducer	X	X	X
NS	8406-142	High Pressure Switch	X	X	X
NS	5201-022	Filter Drier	X	X	X
NS	5651-0246	Electronic Expansion Valve Cable and Stator	X	X	X
NS	113-703	EEV Bracket	X	X	X
NS	5650-046	Rev. Valve Solenoid, Black Casing (San Hua)	X	X	X
NS	5650-051	Dehum. Valve 4-Pipe 1/2 x 1/2 with 24V Solenoid Coil	X	X	X
NS	5651-219	Check Valve	X	X	X
NS	CMA-28	Low Ambient Control (Flare) ②	X	X	X
NS	5451-024	Tubing Isolation Grommet	2	2	2
NS	CMC-29	Freeze Thermostat Kit	X	X	X
NS	8408-044	Evaporator Temp Sensor	X	X	X
NS	1171-028	Filter Door Clip	2	2	2
NS	1171-057	Filter Door Screw	2	2	2
NS	1171-027	Filter Door Screw Retainer	2	2	2
NS	6031-009	Coremax Valve Core	2	2	2
NS	8605-017	Compressor Crankcase Heater	X	X	
NS	8605-018	Compressor Crankcase Heater			X

NS – Not Shown

① – Used with stainless steel cabinet option

② – Optional on these models

This table references drawing on page 6

This page intentionally left blank

CONTROL PANEL

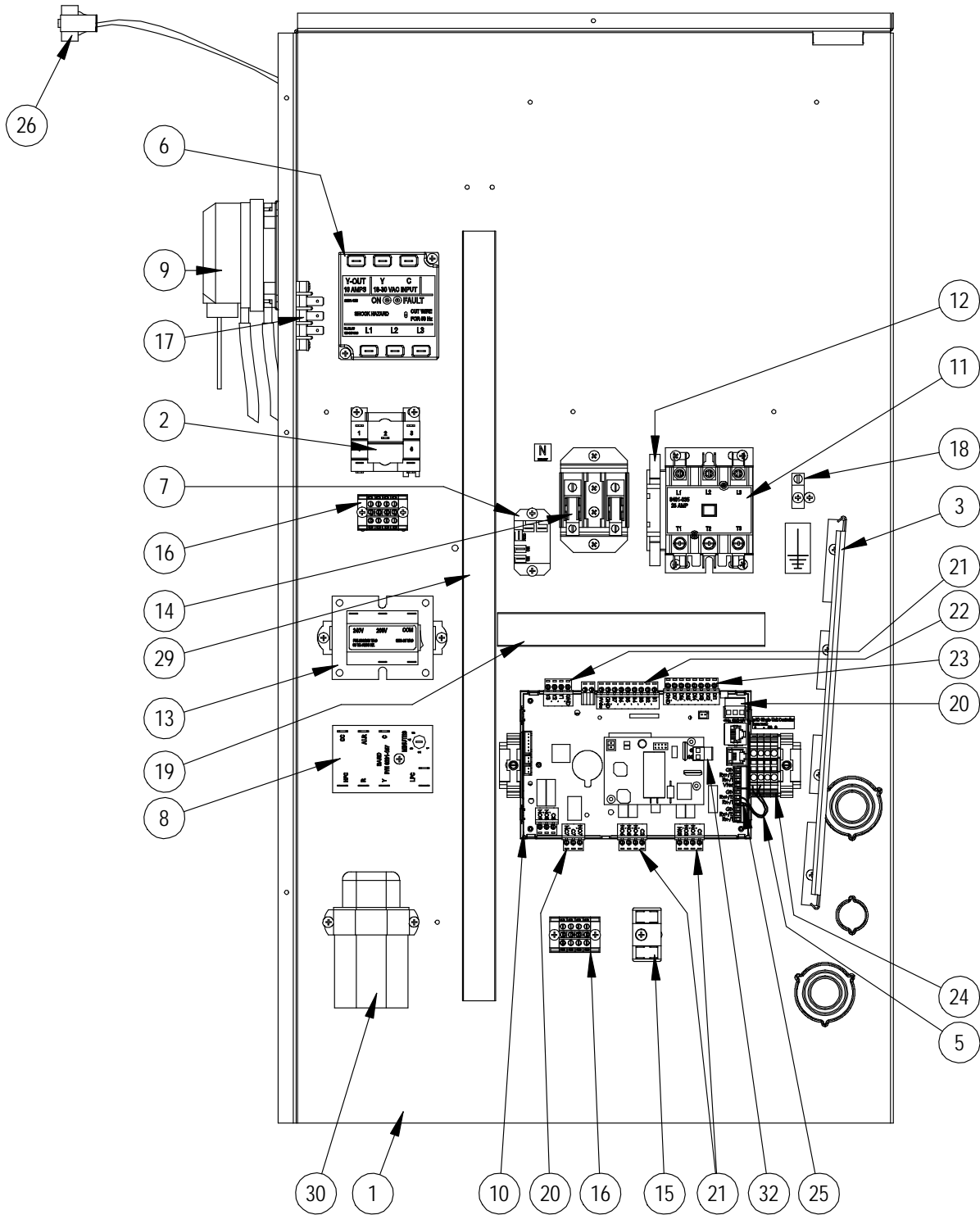

SEXP-877

This drawing is referenced in tables on pages 11, 12 and 13

CONTROL PANEL

Dwg No.	Part Number	Description	W48AAMA	W48AAMB	W48AAMC
1	517X393	Control Panel Assembly	X	X	X
2	8201-032	Blower Relay	X	X	X
3	135-122	Wire Shield	X	X	X
5	3020-004	12" 2 Conductor Sheathed Cable	X	X	X
6	8201-126	3 Phase Line Monitor 50/60 Hz		X	X
7	8201-130	Alarm Relay	X	X	X
8	8201-157	Compressor Control Module	X	X	X
9	8301-057	Filter Switch w/Adjustment	X	X	X
10	8301-068-001*	UPC3-MULTI-TEC 2.0.0	X	X	X
11	8401-035	Contactora 3-Pole 25 Amp		X	X
11	8401-038	Contactora 2-Pole 40 Amp	X		
12	8401-042	Aux. NC Contact		X	X
13	8407-048	Transformer 208/240-24 75VA	X	X	
13	8407-050	Transformer 480/24VAC 75VA			X
14	8607-013	Terminal Block 2 Term. 240V			
15	8607-017	Terminal Block 240V 2 Terminal	X	X	X
16	8607-037	Terminal Block 4 Position	X	X	X
17	8607-041	Park Terminal	X	X	X
18	8611-006	Ground Terminal	X	X	X
19	8611-140-0800	2-1/4" x 1" Cable Duct x 8"	X	X	X
20	8611-147	3-Pin Circuit Board Connector	X	X	X
21	8611-148	4-Pin Circuit Board Connector	X	X	X
22	8611-149	9-Pin Circuit Board Connector	X	X	X
23	8611-185	8-Pin Circuit Board Connector	X	X	X
24	8611-150	Term. Block for DIN Rail RS485	X	X	X
25	8611-192	Small 3-Pin Circuit Board Connector	X	X	X
26	910-1935	Evap. Temp. Sensor Assembly	X	X	X
29	8611-139-2300	1-1/2" X 1-1/2" Cable Duct X 23"	X	X	X
30	8552-005	Outdoor Motor Capacitor		X	
30	8552-004	Outdoor Motor Capacitor			X
30	8552-089	Compressor Capacitor	X		
32	8611-183	2-Pin Circuit Board Connector	X	X	X
NS	3000-1222	Compressor Plug/Harness Wire Assembly	X		
NS	3000-1230	Compressor Plug/Harness Wire Assembly		X	X
NS	8301-075	USB Micro Cable Female to Male	X	X	X
NS	8408-044	Return Air Sensor	X	X	X
NS	8301-066	Mixed Air Sensor	X	X	X
NS	4207-103	Wiring Diagram	X		
NS	4207-203	Wiring Diagram		X	
NS	4207-303	Wiring Diagram			X

* Replacement part will have a letter attached to the end of the part number to designate software version (Example: 8301-068-001**A**). A software upgrade of all PLCs onsite (units and controllers) should accompany any PLC replacement. Latest revisions of software, change log and instructions are available on the Bard website at <http://www.bardhvac.com/software-download/>

NS = Not Shown

CONTROL PANEL

Dwg No.	Part Number	Description	W60ABMA	W60ABMB	W60ABMC
1	517X393	Control Panel Assembly	X	X	X
2	8201-032	Blower Relay	X	X	X
3	135-122	Wire Shield	X	X	X
5	3020-004	12" 2 Conductor Sheathed Cable	X	X	X
6	8201-126	3 Phase Line Monitor 50/60 Hz		X	X
7	8201-130	Alarm Relay	X	X	X
8	8201-157	Compressor Control Module	X	X	X
9	8301-057	Filter Switch w/Adjustment	X	X	X
10	8301-068-001*	UPC3-MULTI-TEC 2.0.0	X	X	X
11	8401-035	Contactors 3-Pole 25 Amp		X	X
11	8401-038	Contactors 2-Pole 40 Amp	X		
12	8401-042	Aux. NC Contact		X	X
13	8407-048	Transformer 208/240-24 75VA	X	X	
13	8407-050	Transformer 480/24VAC 75VA			X
15	8607-017	Terminal Block 240V 2 Terminal	X	X	X
16	8607-037	Terminal Block 4 Position	X	X	X
17	8607-041	Park Terminal	X	X	X
18	8611-006	Ground Terminal	X	X	X
19	8611-140-0800	2-1/4" x 1" Cable Duct x 8"	X	X	X
20	8611-147	3-Pin Circuit Board Connector	X	X	X
21	8611-148	4-Pin Circuit Board Connector	X	X	X
22	8611-149	9-Pin Circuit Board Connector	X	X	X
23	8611-185	8-Pin Circuit Board Connector	X	X	X
24	8611-150	Term. Block for DIN Rail RS485	X	X	X
25	8611-192	Small 3-Pin Circuit Board Connector	X	X	X
26	910-1935	Evap. Temp. Sensor Assembly	X	X	X
29	8611-139-2300	1-1/2" X 1-1/2" Cable Duct X 23"	X	X	X
30	8552-058	Compressor Capacitor	X		
30	8552-004	Outdoor Motor Capacitor			X
30	8552-005	Outdoor Motor Capacitor		X	
32	8611-183	2-Pin Circuit Board Connector	X	X	X
NS	3000-1222	Compressor Plug/Harness Wire Assembly	X		
NS	3000-1230	Compressor Plug/Harness Wire Assembly		X	X
NS	8301-075	USB Micro Cable Female to Male	X	X	X
NS	8408-044	Return Air Sensor	X	X	X
NS	8301-066	Mixed Air Sensor	X	X	X
NS	4207-103	Wiring Diagram	X		
NS	4207-203	Wiring Diagram		X	
NS	4207-303	Wiring Diagram			X

* Replacement part will have a letter attached to the end of the part number to designate software version (Example: 8301-068-001A). A software upgrade of all PLCs onsite (units and controllers) should accompany any PLC replacement. Latest revisions of software, change log and instructions are available on the Bard website at <http://www.bardhvac.com/software-download/>

NS = Not Shown

This table references drawing on page 10

CONTROL PANEL

Dwg No.	Part Number	Description	W72ABMA	W72ABMB	W72ABMC
1	517X393	Control Panel Assembly	X	X	X
2	8201-032	Blower Relay	X	X	X
3	135-122	Wire Shield	X	X	X
5	3020-004	12" 2 Conductor Sheathed Cable	X	X	X
6	8201-126	3 Phase Line Monitor 50/60 Hz		X	X
7	8201-130	Alarm Relay	X	X	X
8	8201-157	Compressor Control Module	X	X	X
9	8301-057	Filter Switch w/Adjustment	X	X	X
10	8301-068-001*	UPC3-MULTI-TEC 2.0.0	X	X	X
11	8401-035	Contactor 3-Pole 25 Amp		X	X
11	8401-038	Contactor 2-Pole 40 Amp	X		
12	8401-042	Aux. NC Contact		X	X
13	8407-048	Transformer 208/240-24 75VA	X	X	
13	8407-050	Transformer 480/24VAC 75VA			X
15	8607-017	Terminal Block 240V 2 Terminal	X	X	X
16	8607-037	Terminal Block 4 Position	X	X	X
17	8607-042	Blower Park Terminal	X	X	X
18	8611-006	Ground Terminal	X	X	X
19	8611-140-0800	2-1/4" x 1" Cable Duct x 8"	X	X	X
20	8611-147	3-Pin Circuit Board Connector	X	X	X
21	8611-148	4-Pin Circuit Board Connector	X	X	X
22	8611-149	9-Pin Circuit Board Connector	X	X	X
23	8611-185	8-Pin Circuit Board Connector	X	X	X
24	8611-150	Term. Block for DIN Rail RS485	X	X	X
25	8611-192	Small 3-Pin Circuit Board Connector	X	X	X
26	910-1935	Evap. Temp. Sensor Assembly	X	X	X
29	8611-139-2300	1-1/2" X 1-1/2" Cable Duct X 23"	X	X	X
30	8552-097	Compressor Capacitor	X		
30	8552-004	Outdoor Motor Capacitor		X	
30	8552-005	Outdoor Motor Capacitor			X
32	8611-183	2-Pin Circuit Board Connector	X	X	X
NS	3000-1510	Compressor Plug/Harness Wire Assembly	X		
NS	3000-1511	Compressor Plug/Harness Wire Assembly		X	X
NS	3000-1512	Motor Power Harness	X	X	X
NS	3000-1513	Motor Control Harness	X	X	X
NS	5650-048	Molded Plug 54" Leads	X	X	X
NS	3000-1360	Wire Assembly (Low Pressure Transducer)	X	X	X
NS	8301-075	USB Micro Cable Female to Male	X	X	X
NS	8406-153	Low Pressure Transducer	X	X	X
NS	8408-044	Return Air Sensor	X	X	X
NS	8301-066	Mixed Air Sensor	X	X	X
NS	4207-106	Wiring Diagram	X		
NS	4207-206	Wiring Diagram		X	
NS	4207-306	Wiring Diagram			X

* Replacement part will have a letter attached to the end of the part number to designate software version (Example: 8301-068-001**A**). A software upgrade of all PLCs onsite (units and controllers) should accompany any PLC replacement. Latest revisions of software, change log and instructions are available on the Bard website at <http://www.bardhvac.com/software-download/>

NS = Not Shown

This table references drawing on page 10

BLOWER ASSEMBLY

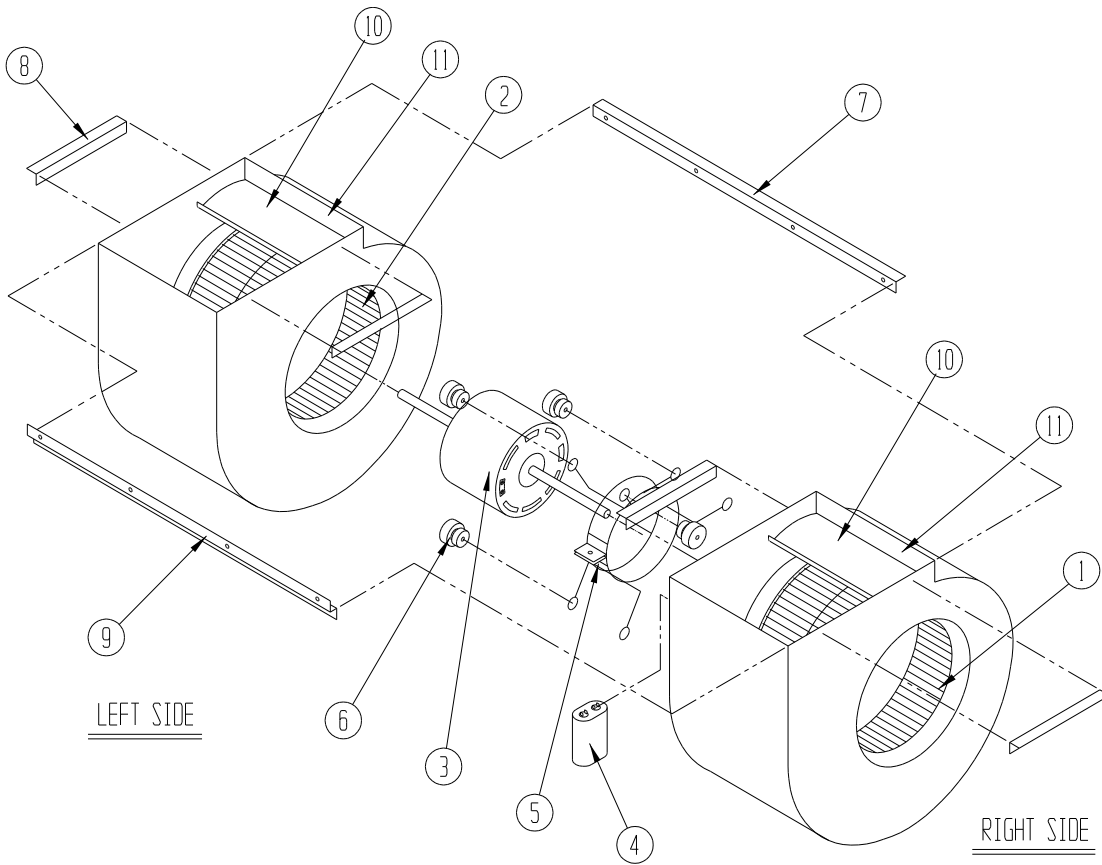

SEXP-178

Dwg No.	Part Number	Description	S900-320	S900-321	S900-185	S900-186
1	5152-011	10 Inch Wheel (CW)	X	X	X	X
1	5152-057	9 Inch Wheel (CW)	X	X		
2	5152-012	10 Inch Wheel (CW)	X	X	X	X
2	5152-058	9 Inch Wheel (CW)	X	X		
3	8105-061	Blower Motor (230/208)	X			
3	8105-062	Blower Motor (460)		X		
3	8106-046	Blower Motor (230/208)			X	
3	8106-025	Blower Motor (460)				X
4	8552-091	Capacitor	X	X	X	
4	8552-005	Capacitor				X
5	8200-040	Motor Mount	X	X	X	X
6	5451-011	Grommets	6	6	6	6
7	105-881	Back Brace	X	X	X	X
8	105-880	Side Angle	4	4	4	4
9	103-389	Front Brace	X	X	X	X
10	151-101	Housing	2	2	2	2
11	144-166	Diffuser	2	2	2	2

BLOWER ASSEMBLY

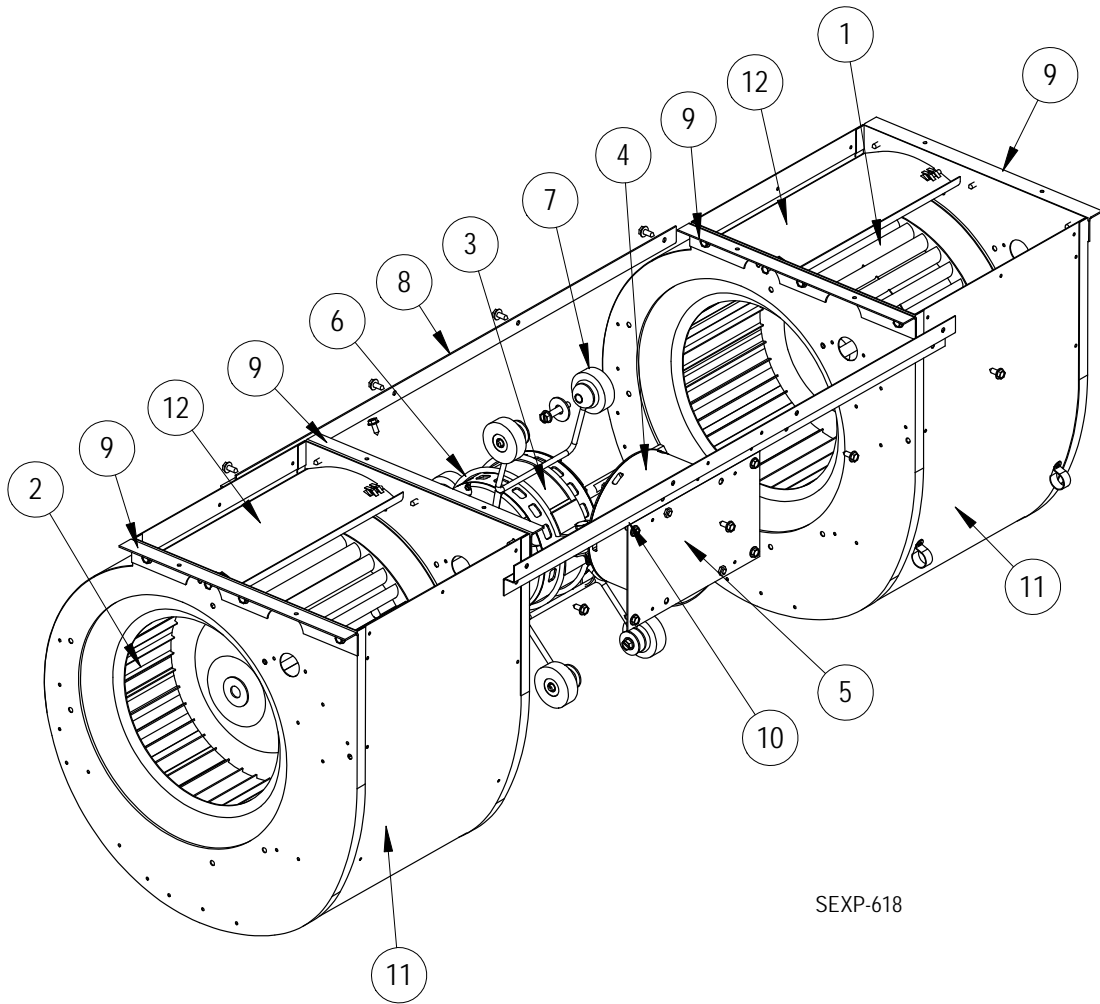

SEXP-618

Dwg. No.	Part Number	Description	S900-348-001	S900-349-001
1	5152-011	10-Inch Wheel (CW)	X	X
2	5152-012	10-Inch Wheel (CCW)	X	X
3	8107-019-0135	3/4 HP Programmed Motor w/Control	X	
3	8107-026-0136	3/4 HP Programmed Motor w/Control		X
5	112-580	Blower Motor Control Bracket	X	X
6	8200-040	Motor Mount	X	X
7	5451-011	Grommets	6	6
8	105-881	Back Brace	X	X
9	105-880	Side Angle	4	4
10	103-389	Front Brace	X	X
11	151-101	Housing	2	2
12	144-166	Diffuser	2	2