

REPLACEMENT PARTS MANUAL

BLOWER COIL UNIT

MODELS: BC35B, BC36B

Manual 2110-105

Revision C

Date 4-01-93

Supersedes 8-30-91

* GENERAL NOTES *

*Revised and/or additional pages may be issued from time to time.
*A complete and current manual consists of pages dated as shown in the following index.

** INDEX **

<u>Page Description</u>	<u>Page</u>	<u>Date</u>	<u>Supersedes</u>
Cabinet Components--Exploded View	1	09-01-90	07-11-89
" " --Usage List	2	04-01-93	09-01-90
Functional Components--Exploded View	3	08-30-91	09-01-90
" " --Usage List	4	08-30-91	07-11-89

*** IMPORTANT ***

Contact the installing and/or local Bard distributor for all parts requirements. Make sure you have the complete model and serial number available from the unit rating plate.

BARD MANUFACTURING COMPANY

BRYAN, OHIO 43506

CABINET COMPONENTS

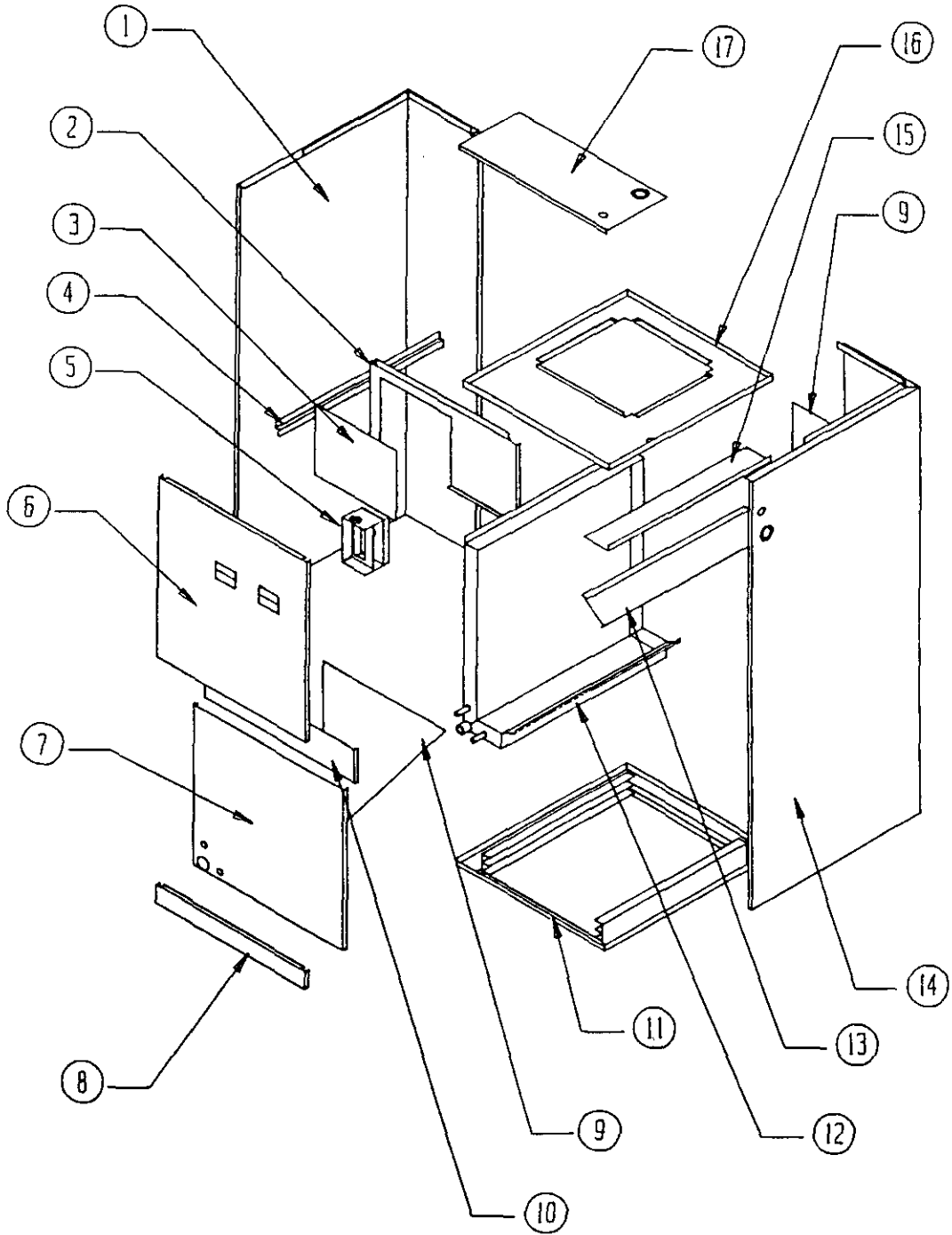

Date: 9-01-90
Supersedes: 7-11-89

CABINET COMPONENTS

Dwg. No.	Part No.	Description	BC35B	BC36B
1	500-194	Left Side (See Note)	A	A
1	500-216	Left Side (See Note)	B	B
2	120-139	Partition	X	X
3	136-141	Block Off Plate	X	X
4	102-392	Coil Assembly Support (Left Side)	X	X
5	117-116	Low Voltage Box Assembly	X	X
6	552-159	Upper Door	X	X
7	552-160	Lower Door (See Note)	A	A
7	552-191	Lower Door (See Note)	B	B
8	552-161	Filter Door	X	X
9	136-139	Coil Support	X	X
10	140-149	Quick Connect Support (See Note)	A	A
10	540-167	Quick Connect Support (See Note)	B	B
11	127-154	Lower Base Assembly	X	X
12	123-071	Water Pan Assembly	X	X
13	136-140	Top Coil Fill	X	X
14	500-193	Right Side (See Note)	A	A
14	500-215	Right Side (See Note)	B	B
15	140-147	Coil Assembly Support (Right Side)	X	X
16	126-155	Blower Base	X	X
17	507-117	Top Assembly	X	X

NOTE A: For units produced before date code L90.

NOTE B: For units produced with date code L90 and after.

Date: 4-01-93
Supersedes: 9-01-90

FUNCTIONAL COMPONENTS

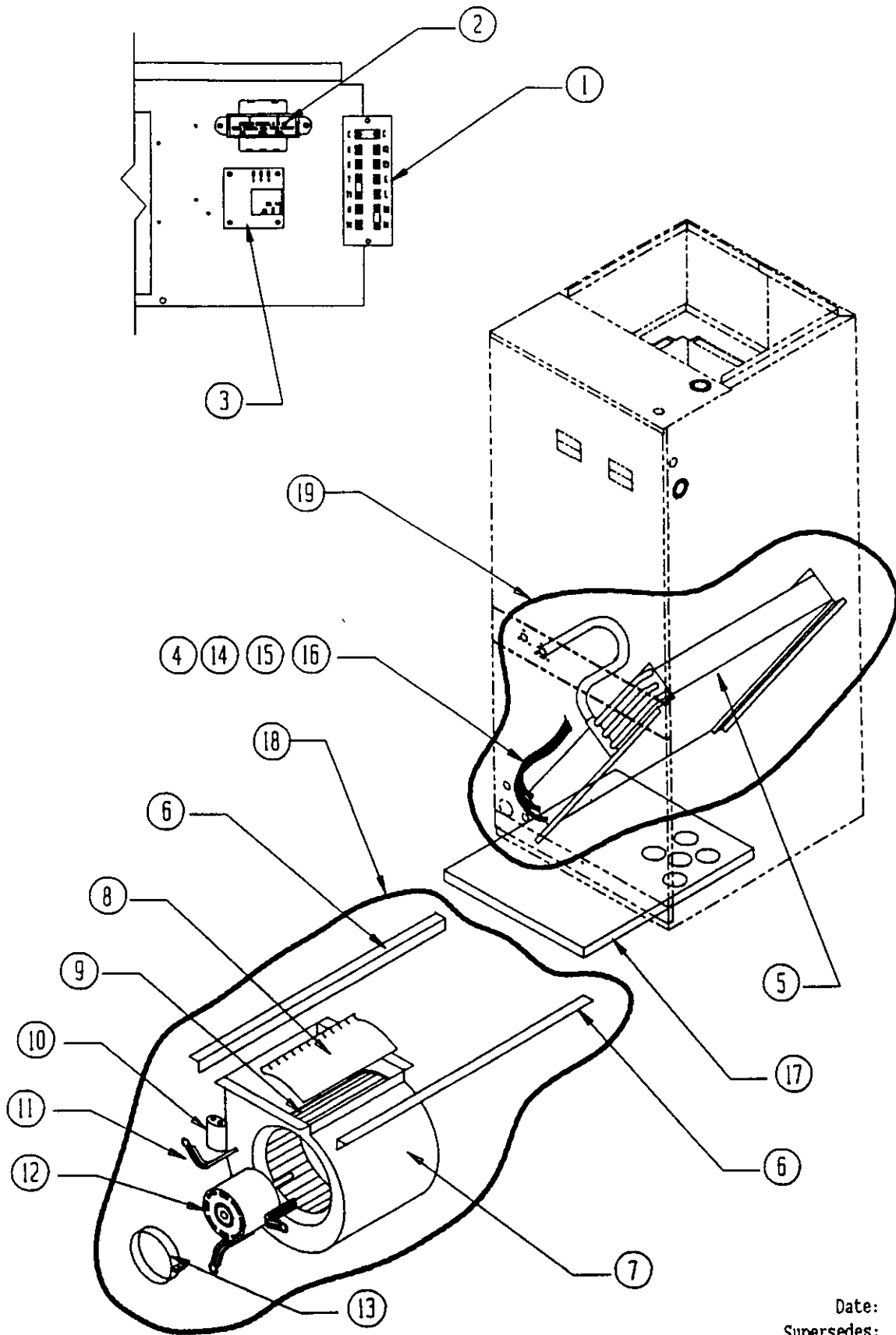

Date: 8-30-91
Supersedes: 9-01-90

FUNCTIONAL COMPONENTS

Dwg. No.	Part No.	Description	BC35B	BC36B
1	8607-019	Terminal Strip	X	X
2	8407-035	Transformer 55VA	X	X
3	8201-056	Solid State Blower Control	X	X
4	5811-010	Capillary Tube	3	
4	5625-009	Distributor		X
5	5060-055	Evaporator Coil	X	
5	5060-054	Evaporator Coil		X
6	104-813	Blower Angle	2	2
7	151-087	Blower Housing Assembly	X	X
8	144-128	Blower Diffuser	X	X
9	5152-014	Blower Wheel 10 x 9	X	X
10	8552-025	Capacitor 7-1/2 / 440V	X	X
11	8200-034	Motor Mount Arm	3	3
12	8105-022	Motor 1/3 HP 230V	X	X
13	8200-033	Motor Mount Band		X
14	5625-072	.072 Orifice		X
15	5625-002	5782 Coupling to R.H. Thread Adapter		X
16	5651-036	Check Valve	X	
17	7004-010	Filter 16 x 20 x 1	X	X
18	900-147	Complete Blower Assembly	X	X
19	600-0023	Complete Coil Assembly W/Drain Pan	X	
19	600-0024	Complete Coil Assembly W/Drain Pan		X
	4088-110	Wiring Diagram	X	X

Date: 8-30-91
Supersedes: 7-11-89

