

# REPLACEMENT PARTS MANUAL

SPLIT  
HEAT PUMPS  
MODELS 42UHPQA, 48UHPQB, 48UHPQB-B  
60UHPQB, 60UHPQB-B

Manual 2110-055

Revision D

Date 10-07-92

Supersedes 01-01-92

\*\*\*\*\*  
\* GENERAL NOTES \*  
\*\*\*\*\*

\*Revised and/or additional pages may be issued from time to time.  
\*A complete and current manual consists of pages dated as shown in the following index.

\*\*\*\*\*  
\*\* INDEX \*\*  
\*\*\*\*\*

<u>Page Description</u>	<u>Page</u>	<u>Date</u>	<u>Supersedes</u>
Functional and Cabinet Components--Exploded View	1	10-07-92	01-01-92
" " " --Usage List	2	10-07-92	01-01-92
" " " --Usage List	3	10-07-92	01-01-92

\*\*\*\*\*  
\*\*\* IMPORTANT \*\*\*  
\*\*\*\*\*

Contact the installing and/or local Bard distributor for all parts requirements. Make sure you have the complete model and serial number available from the unit rating plate.

BARD MANUFACTURING COMPANY

BRYAN, OHIO 43506

FUNCTIONAL AND CABINET COMPONENTS

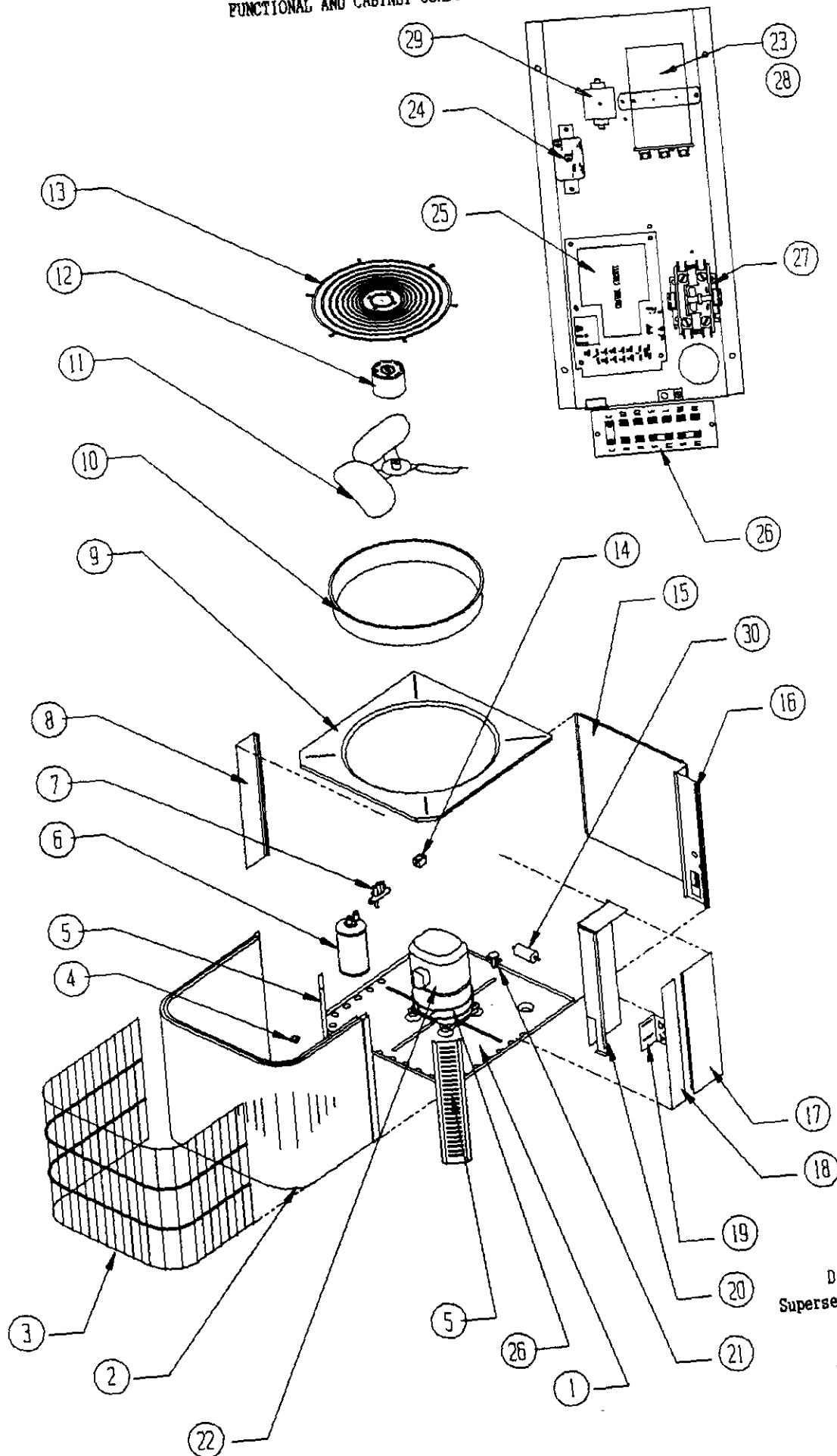

Date: 10-07-92  
 Supersedes: 01-01-92  
 2110-055  
 Page: 1

FUNCTIONAL AND CABINET COMPONENTS

Item No.	Part No.	Description	4 2 U H P Q A	4 8 U H P Q B	4 8 U H P Q B   B	6 0 U H P Q B   B	6 0 U H P Q B   B
1	127-114	Base Assembly	X	X	X	X	X
2	600-0026	Condenser Coil Assembly 5051-060	X	X	X		
2	600-0027	Condenser Coil Assembly 5051-061				X	X
3	7051-019	Coil Grille	X	X	X		
3	7051-020	Coil Grille				X	X
4	8408-023	Defrost Sensor	X	X	X	X	X
5	148-055	Front Corner	X	X	X		
5	148-058	Front Corner				X	X
7	5650-006	Reversing Valve	X				
7	5650-010	Reversing Valve		X	X	X	X
8	148-056	Left Rear Corner	X	X	X		
8	148-059	Left Rear Corner				X	X
9	106-093	Top	X	X	X	X	X
10	167-011	Fan Venturi	X	X	X	X	X
11	5151-036	Fan Blade	X	X	X		
11	5151-037	Fan Blade				X	X
12	8104-007	Fan Motor 1/3 HP	X	X	X		
12	8105-028	Fan Motor 1/2 HP				X	X
13	7051-018	Fan Motor Mount Grille	X	X	X	X	X
14	5650-008	Reversing Valve Solenoid	X	X	X	X	X
15	152-144	Service Door	X	X	X		
15	152-143	Service Door				X	X
16	148-054	Control Panel Corner	X	X	X		
16	148-057	Control Panel Corner				X	X
17	132-064	Control Panel Cover	X	X	X		
17	132-065	Control Panel Cover				X	X
18	100-146	Right Side	X	X	X		
18	100-147	Right Side				X	X
19	140-174	Quick Connect Support	X	X	X	X	X
20	116-094	Control Panel Wrapper	X	X	X		
20	116-096	Control Panel Wrapper				X	X
21	5651-077	Expansion Valve	X				
21	5651-087	Expansion Valve		X	X		
21	5651-079	Expansion Valve				X	X
22	8000-109	Compressor ZR40K1-PFV-230	X				
22	8000-119	Compressor ZR49K2-PFV-230		X			
22	8000-120	Compressor ZR49K2-TF5-230			X		
22	8000-121	Compressor ZR61K2-PFV-230				X	
22	8000-122	Compressor ZR61K2-TF5-230					X
	8002-005	Compressor Sound Cover				X	X
	8002-006	Compressor Sound Cover		X	X		
23	8552-049	Capacitor 35+5/440V	X				
23	8552-053	Capacitor 40+5/440V		X			
23	8552-054	Capacitor 55+5/440V				X	
24	8201-008	Emergency Heat Relay	X	X	X	X	X
25	8201-068	Heat Pump Control	X	X	X	X	X
26	8605-012	Crankcase Heater (Wraparound)			X		X

FUNCTIONAL AND CABINET COMPONENTS

Item No.	Part No.	Description	4 2 U H P Q A	4 8 U H P Q B	4 8 U H P Q B   B	6 0 U H P Q B	6 0 U H P Q B   B
26	8607-019	Terminal Strip	x	x	x	x	x
27	8401-003	Compressor Contactor 30 Amp 1 Pole	x	x			
27	8401-027	Compressor Contactor 30 Amp 3 Pole W/Aux. Contact			x		x
27	8401-016	Compressor Contactor 35 Amp 1 Pole				x	
30	5201-009	Heat Pump Filter Drier	x	x	x	x	x
33	8406-040	High Pressure Switch	x	x	x	x	x
	4087-112	Wiring Diagram	x				
	4087-113	Wiring Diagram		x		x	
	4087-210	Wiring Diagram			x		x
	5625-078	Restrictor w/.078" Orifice	x	x	x		
	5625-092	Restrictor w/.092" Orifice				x	x
	8408-008	Outdoor Thermostat	x	x	x	x	x

Date: 10-07-92  
Supersedes: 01-01-92