

# REPLACEMENT PARTS MANUAL

## SPLIT HEAT PUMPS MODELS 24UHPQA, 30UHPQA, 36UHPQA

Manual 2110-054

Revision --

Date 7-11-89

Supersedes

\*\*\*\*\*  
\* GENERAL NOTES \*  
\*\*\*\*\*

\*Revised and/or additional pages may be issued from time to time.  
\*A complete and current manual consists of pages dated as shown in the following index.

\*\*\*\*\*  
\*\* INDEX \*\*  
\*\*\*\*\*

<u>Page Description</u>	<u>Page</u>	<u>Date</u>	<u>Supersedes</u>
Functional and Cabinet Components--Exploded View	1	7-11-89	
" " " --Usage List	2	7-11-89	

\*\*\*\*\*  
\*\*\* IMPORTANT \*\*\*  
\*\*\*\*\*

Contact the installing and/or local Bard distributor for all parts requirements. Make sure you have the complete model and serial number available from the unit rating plate.

BARD MANUFACTURING COMPANY

BRYAN, OHIO 43506

FUNCTIONAL AND CABINET COMPONENTS

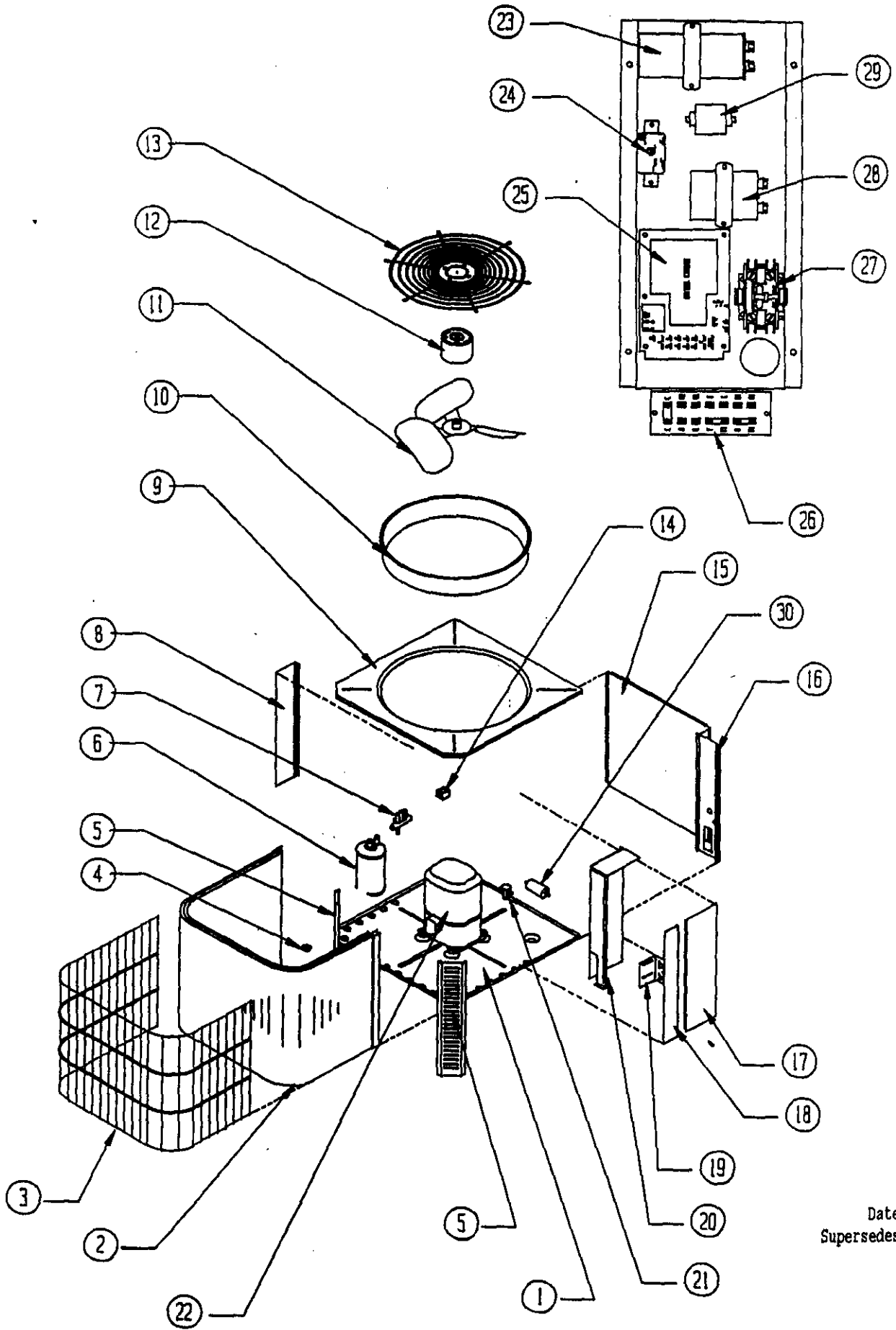

Date: 7-11-89  
Supersedes:

FUNCTIONAL AND CABINET COMPONENTS

Hi pressure Switch  
8406-040

Item No.	Part No.	Description	2 4 U H P Q A	3 0 U H P Q A	3 6 U H P Q A
1	127-114	Base Assembly	X	X	X
2	600-0020	Condenser Coil Assembly	X	X	
2	600-0021	Condenser Coil Assembly			X
3	7051-019	Coil Grille	X	X	X
4	8408-019	Ther. Sensor	X	X	X
5	148-055	Front Cover	X	X	X
6	5202-016	Accumulator	X	X	X
7	5650-005	Reversing Valve	X		
7	5650-013	Reversing Valve		X	X
8	148-056	Left Rear Corner	X	X	X
9	<del>106-096</del>	Top <span style="margin-left: 20px;">106-093</span>	X	X	X
10	167-011	Fan Venturi	X	X	X
11	5151-039	Fan Blade	X	X	X
12	8102-010	Fan Motor 1/6 HP	X	X	X
13	7051-018	Fan Motor Mount Grille	X	X	X
14	5650-008	Reversing Valve Solenoid	X	X	X
15	152-144	Service Door	X	X	X
16	148-054	Control Panel Cover	X	X	X
17	132-064	Control Panel Cover	X	X	X
18	100-146	Right Side	X	X	X
19	140-144	Quick Connect Support	X	X	X
20	116-094	Control Panel Wrapper	X	X	X
21	5651-070	Expansion Valve		X	
21	5651-071	Expansion Valve			X
21	5651-072	Expansion Valve	X		
22	8000-099	Compressor H23B283ABCA		X	
22	8000-055	Compressor CRH3-0275-PFV			X
22	8000-101	Compressor H23B223ABC	X		
23	8552-032	Capacitor 35/370V		X	
23	8552-035	Capacitor 40/370V			X
23	8552-045	Capacitor 30/370	X		
24	8201-008	Emergency Heat Relay	X	X	X
25	8201-055	Heat Pump Control	X	X	X
26	8607-019	Terminal Strip	X	X	X
27	8401-007	Compressor Contactor 25 Amp	X	X	X
28	8552-002	Capacitor 5/370V	X	X	X
29	8551-005	Motor Starting Device	X	X	X
30	5201-009	Heat Pump Filter Drier	X	X	X
31	8002-001	Sound Cover	X	X	
32	8002-002	Sound Cover			X
	4087-110	Wiring Diagram	X	X	X
	5625-059	Restrictor w/.059" Orifice	X		
	5625-067	Restrictor w/.067" Orifice		X	
	5625-072	Restrictor w/.072" Orifice			X
	8408-008	Outdoor Thermostat			Field Inst.

Date: 7-11-89  
Supersedes:

