

REPLACEMENT PARTS MANUAL

SPLIT AIR CONDITIONER

MODELS: 18UACQA, 18UACSA, 24UACQB, 24UACSB,
30UACQA, 30UACSA, 36UACQA, 36UACSA,
42UACQB, 42UACSB, 48UACQB, 48UACSB,
60UACQB, 60UACSB

Manual 2110-004

Revision E

Date 04-24-93

Supersedes 01-09-92

* GENERAL NOTES *

*Revised and/or additional pages may be issued from time to time.
*A complete and current manual consists of pages dated as shown in the following index.

** INDEX **

| <u>Page Description</u> | <u>Page</u> | <u>Date</u> | <u>Supersedes</u> |
|--|-------------|-------------|-------------------|
| Functional and Cabinet Components--Exploded View | 1 | 04-24-93 | 08-01-90 |
| " " " --Usage List | 2 | 04-24-93 | 01-09-92 |
| Functional and Cabinet Components--Exploded View | 3 | 04-24-93 | 08-01-90 |
| " " " --Usage List | 4 | 04-24-93 | 01-09-92 |

*** IMPORTANT ***

Contact the installing and/or local Bard distributor for all parts requirements. Make sure you have the complete model and serial number available from the unit rating plate.

BARD MANUFACTURING COMPANY

BRYAN, OHIO 43506

FUNCTIONAL AND CABINET COMPONENTS

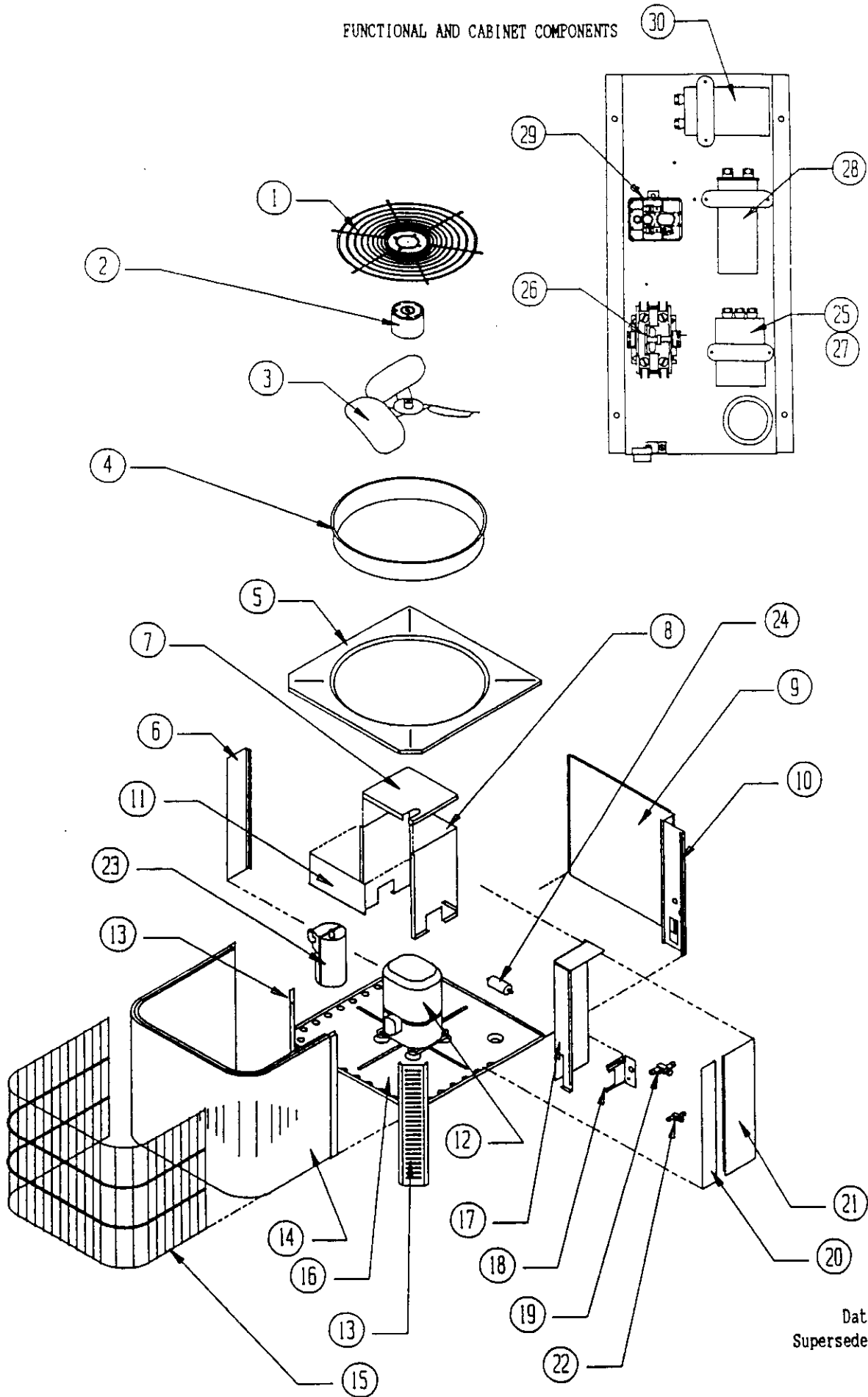

Date: 04-24-93
Supersedes: 08-01-90

FUNCTIONAL AND CABINET COMPONENTS

| Dwg. No. | Part No. | Description | 1 8 U A C Q A | 1 8 U A C S A | 2 4 U A C Q B | 2 4 U A C S B | 3 0 U A C Q A | 3 0 U A C S A | 3 6 U A C Q A | 3 6 U A C S A | 3 6 U A C S A | 3 6 U A C S A | 4 2 U A C Q B | 4 2 U A C S B | 4 2 U A C S B | 4 8 U A C Q B | 4 8 U A C S B | 4 8 U A C S B | 6 0 U A C Q B | 6 0 U A C S B | 6 0 U A C S B | |
|----------|----------|---------------------------|---------------------------------|---------------------------------|---------------------------------|---------------------------------|---------------------------------|---------------------------------|---------------------------------|---------------------------------|---------------------------------|---------------------------------|---------------------------------|---------------------------------|---------------------------------|---------------------------------|---------------------------------|---------------------------------|---------------------------------|---------------------------------|---------------------------------|---|
| 1 | 7051-018 | Fan & Motor Mount Grille | x | x | x | x | x | x | x | x | x | x | x | x | x | x | x | x | x | x | x | x |
| 2 | 8102-010 | Motor--Fan | x | x | x | x | x | x | x | x | x | | | | | | | | | | | |
| 2 | 8104-007 | Motor--Fan | | | | | | | | | | | x | x | x | x | x | x | x | x | x | x |
| 3 | 5151-036 | Fan Blade | | | | | | | | | | | x | x | x | x | x | x | x | x | x | x |
| 3 | 5151-039 | Fan Blade | x | x | x | x | x | x | x | x | x | | | | | | | | | | | |
| 4 | 167-011 | Fan Venturi | x | x | x | x | x | x | x | x | x | x | x | x | x | x | x | x | x | x | x | x |
| 5 | 106-093 | Top | x | x | x | x | x | x | x | x | x | x | x | x | x | x | x | x | x | x | x | x |
| 6 | 148-056 | Left Rear Corner | x | x | x | x | x | x | x | x | x | x | x | x | x | x | x | x | x | x | x | x |
| 9 | 152-144 | Service Door | x | x | x | x | x | x | x | x | x | x | x | x | x | x | x | x | x | x | x | x |
| 10 | 148-054 | Control Panel Corner | x | x | x | x | x | x | x | x | x | x | x | x | x | x | x | x | x | x | x | x |
| 12 | 8000-052 | Compressor CRG3-0250-PFV | | | | | | | x | x | | | | | | | | | | | | |
| 12 | 8000-053 | Compressor CRG3-0250-TF5 | | | | | | | | | x | | | | | | | | | | | |
| 12 | 8000-130 | Compressor CR38K6-PFV-270 | | | | | | | | | | | x | x | | | | | | | | |
| 12 | 8000-131 | Compressor CR38K6-TF5-270 | | | | | | | | | | | | | x | | | | | | | |
| 12 | 8000-126 | Compressor CR42K6-PFV-270 | | | | | | | | | | | | | | x | x | | | | | |
| 12 | 8000-127 | Compressor CR42K6-TF5-270 | | | | | | | | | | | | | | | x | | | | | |
| 12 | 8000-100 | Compressor AW5517F | x | x | | | | | | | | | | | | | | | | | | |
| 12 | 8000-110 | Compressor AW5519F | | | x | x | | | | | | | | | | | | | | | | |
| 12 | 8000-095 | Compressor 703087-06-0813 | | | | | x | x | | | | | | | | | | | | | | |
| 12 | 8000-151 | Compressor H25A54QCBC | | | | | | | | | | | | | | | | | | x | x | |
| 12 | 8000-152 | Compressor H25A54QDBL | | | | | | | | | | | | | | | | | | | | x |
| | 8002-007 | Compressor Sound Cover | | | | | | | | | | | x | x | x | x | x | x | | | | |
| | 8002-008 | Sound Cover | | | | | | | | | | | | | | | | | | x | x | x |
| | 8002-009 | Sound Base Pad | | | | | | | | | | | | | | | | | | x | x | x |
| 13 | 148-055 | Front Corner | x | x | x | x | x | x | x | x | x | x | x | x | x | x | x | x | x | x | x | x |
| 14 | 600-0015 | Condenser Coil 5051-043 | | | | | x | x | | | | | | | | | | | | | | |
| 14 | 600-0017 | Condenser Coil 5051-044 | | | | | | | x | x | x | | | | | | | | | | | |
| 14 | 600-0012 | Condenser Coil 5051-045 | | | | | | | | | | | x | x | x | | | | | | | |
| 14 | 600-0018 | Condenser Coil 5051-046 | | | | | | | | | | | | | | x | x | x | x | x | x | x |
| 14 | 600-0019 | Condenser Coil 5051-058 | x | x | x | x | | | | | | | | | | | | | | | | |
| 15 | 7051-019 | Coil Grille | x | x | x | x | x | x | x | x | x | x | x | x | x | x | x | x | x | x | x | x |
| 16 | 127-113 | Base Assembly | x | x | x | x | x | x | x | x | x | x | x | x | x | x | x | x | x | x | x | x |

Date: 04-24-93
Supersedes: 08-01-90