

REPLACEMENT PARTS MANUAL

SPLIT
AIR CONDITIONER
MODELS 42ECQ1, 42ECS1, 48ECQ2, 48ECS2,
60ECQ1, 60ECS1

Manual 2110-003

Revision --

Date 7-11-89

Supersedes

* GENERAL NOTES *

*Revised and/or additional pages may be issued from time to time.
*A complete and current manual consists of pages dated as shown in the following index.

** INDEX **

<u>Page Description</u>	<u>Page</u>	<u>Date</u>	<u>Supersedes</u>
Functional and Cabinet Components--Exploded View	1	7-11-89	
" " " --Usage List	2	7-11-89	
Functional and Cabinet Components--Exploded View	3	7-11-89	
" " " --Usage List	4	7-11-89	

*** IMPORTANT ***

Contact the installing and/or local Bard distributor for all parts requirements. Make sure you have the complete model and serial number available from the unit rating plate.

FUNCTIONAL AND CABINET COMPONENTS

Item No.	Part No.	Description	4	4	4	4	6	6	4	4	6	4	4	6
			2	2	8	8	0	0	2	8	0	2	8	0
			E	E	E	E	E	E	E	E	E	E	E	E
			C	C	C	C	C	C	C	C	C	C	C	C
			Q	S	Q	S	Q	S	Q	Q	Q	Q	Q	Q
			1	1	2	2	1	1	1	2	1	1	2	1
			-	-	-	-	-	-	B	B	B	C	C	C
1	127-018	Base Assembly	X	X	X	X	X	X	X	X	X	X	X	X
2	506-017	Top	X	X	X	X	X	X	X	X	X	X	X	X
3	124-007	Fan Shroud	X	X	X	X	X	X	X	X	X	X	X	X
4	100-024	Side	X	X	X	X	X	X	X	X	X	X	X	X
5	552-016	Service Door	X	X	X	X	X	X	X	X	X	X	X	X
6	548-063	Compressor Corner		X		X		X						
6	548-031	Compressor Corner	X		X		X		X	X	X	X	X	X
7	140-124	Base Valve Support		X		X		X						
8	520-019	Compressor Partition	X	X	X	X	X	X	X	X	X	X	X	
9	548-030	Coil Corner	X	X	X	X	X	X	X	X	X	X	X	
10	132-070	Control Panel Cover	X	X	X	X	X	X	X	X	X	X	X	
11	116-032	Control Panel	X	X	X	X	X	X	X	X	X	X	X	X
12	7051-004	Inlet Grille	X	X	X	X	X	X	X	X	X	X	X	X
13	7051-005	Condenser Grille	X	X	X	X	X	X	X	X	X	X	X	X
14	5051-009	Condenser Coil	X	X	X	X		X	X		X	X		
14	5051-024	Condenser Coil					X	X			X			X
15	8000-063	Compressor CRK3-0325-PFV	X	X										
15	8000-064	Compressor CRK3-0325-TF5						X						
15	8000-067	Compressor AG112ET			X	X								
15	8000-030	Compressor AG111RT							X					
15	8000-027	Compressor AG122ET					X	X						
15	8000-065	Compressor CRK3-0325-TFD										X		
15	8000-031	Compressor AG122RT									X			
15	8000-047	Compressor AG111UT											X	
15	8000-048	Compressor AG122UT												X
16	5151-017	Fan Blade FA2430-4B	X	X	X	X	X	X	X	X	X	X	X	X
17	8105-021	Motor--Fan 1/3 HP	X	X	X	X	X	X	X	X	X			
17	8105-030	Motor--Fan 1/3 HP 460V										X	X	X
18	8200-004	Motor Mount--Fan	X	X	X	X	X	X	X	X	X	X	X	X
19	5651-054	Base Valve		X		X		X						
20	5651-051	Base Valve		X		X		X						
21	8401-025	Contactora--Comp 35A	X	X	X	X	X	X						
21	8401-002	Contactora--Comp 25A 3 Pole							X	X	X	X	X	X
22	8552-030	Capacitor 40/440V	X	X										
22	8552-036	Capacitor 70/370V			X	X								
22	8552-031	Capacitor 45/440V					X	X						
23	8552-026	Capacitor 15/370V	X	X	X	X	X	X	X	X	X	X	X	X
	4025-120	Wiring Diagram	X	X	X	X	X	X						
	4025-210	Wiring Diagram							X	X	X			
	4025-310	Wiring Diagram										X	X	X

Date: 7-11-89
Supersedes:

FUNCTIONAL AND CABINET COMPONENTS

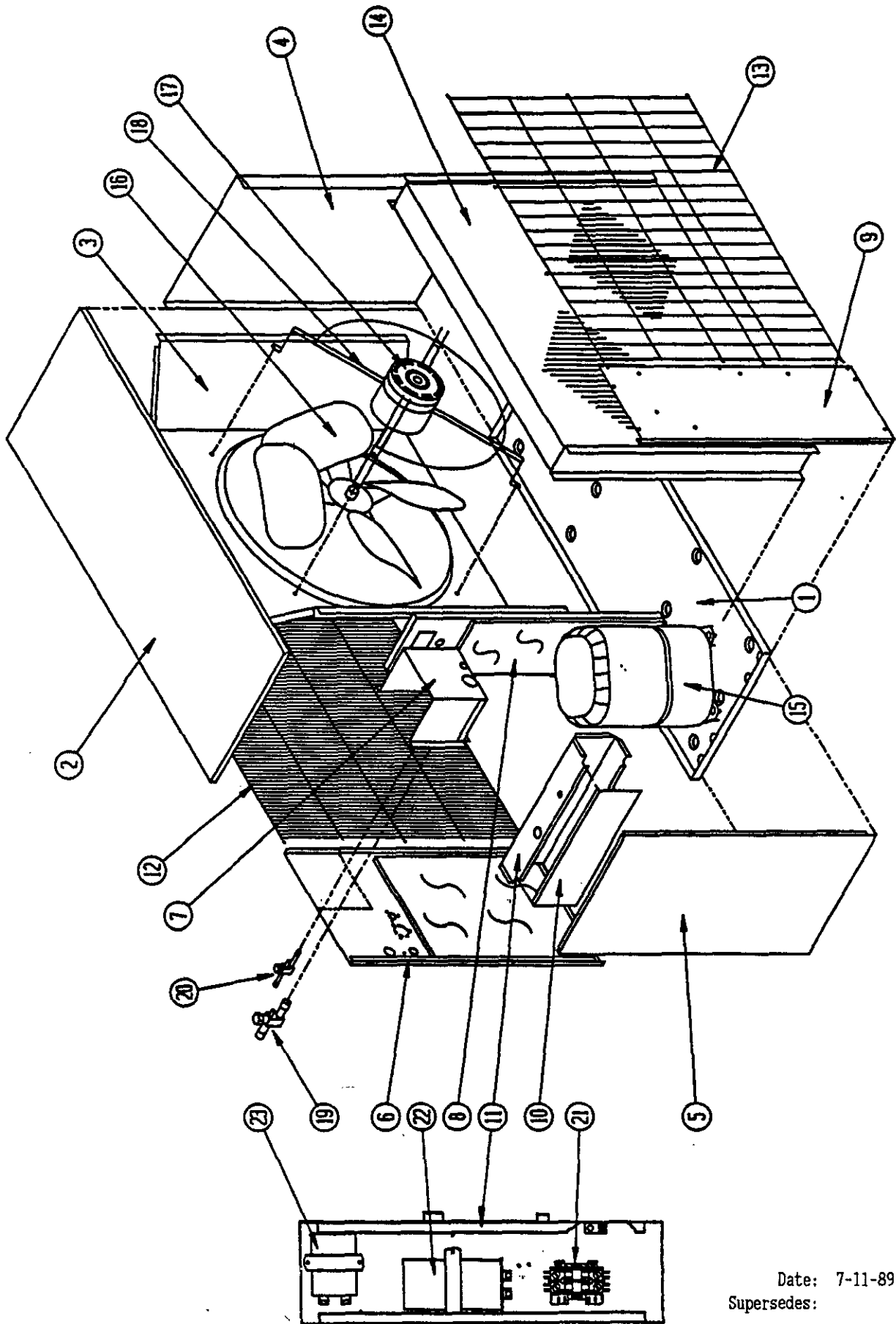

Date: 7-11-89
Supersedes:

FUNCTIONAL AND CABINET COMPONENTS

Item No.	Part No.	Description	4 2 E C Q 1 D	4 2 E C Q 1 E	4 2 E C Q 1 F	4 8 E C Q 2 E	4 8 E C Q 2 F	4 8 E C Q 2 G	6 0 E C Q 1 E	6 0 E C Q 1 F	6 0 E C Q 1 G
1	127-018	Base Assembly	X	X	X	X	X	X	X	X	X
2	506-017	Top	X	X	X	X	X	X	X	X	X
3	124-007	Fan Shroud	X	X	X	X	X	X	X	X	X
4	100-024	Side	X	X	X	X	X	X	X	X	X
5	552-016	Service Door	X	X	X	X	X	X	X	X	X
6	548-031	Compressor Corner	X	X	X	X	X	X	X	X	X
8	520-019	Compressor Partition	X	X	X	X	X	X	X	X	X
9	548-030	Coil Corner	X	X	X	X	X	X	X	X	X
10	132-070	Control Panel Cover	X	X	X	X	X	X	X	X	X
11	116-032	Control Panel	X	X	X	X	X	X	X	X	X
12	7051-004	Inlet Grille	X	X	X	X	X	X	X	X	X
13	7051-005	Condenser Grille	X	X	X	X	X	X	X	X	X
14	5051-009	Condenser Coil	X	X	X	X	X				
14	5051-024	Condenser Coil							X	X	X
15	8000-064	Compressor CRK3-0325-TF5		X							
15	8000-030	Compressor AG111RT				X					
15	8000-065	Compressor CRK3-0325-TFD			X						
15	8000-047	Compressor AG111UT				X					
15	8000-039	Compressor	X								
15	8000-026	Compressor					X				
15	8000-078	Compressor						X			
15	8000-079	Compressor							X		
15	8000-077	Compressor									X
16	5151-017	Fan Blade FA2430-4B	X	X	X	X	X	X	X	X	X
17	8105-014	Motor--Fan 1/3 HP	X	X	X	X	X	X	X	X	X
18	8200-004	Motor Mount--Fan	X	X	X	X	X	X	X	X	X
21	8401-025	Contactor--Comp 35A						X			X
21	8401-002	Contactor--Comp 25A 3 Pole		X	X	X			X	X	
21	8401-010	Contactor	X								
22	8552-030	Capacitor 40/440V									X
22	8552-028	Capacitor 35/440V	X								
22	8552-031	Capacitor 45/440V						X			
23	8552-005	Capacitor 10/370V	X	X	X	X	X	X	X	X	X
	4025-411	Wiring Diagram	X								
	4025-510	Wiring Diagram		X							
	4025-610	Wiring Diagram			X		X			X	
	4025-511	Wiring Diagram				X			X		
	4025-412	Wiring Diagram						X			
	4025-410	Wiring Diagram									X

Date: 7-11-89
Supersedes: