

INSTALLATION INSTRUCTIONS

I-TEC Wall Sleeve for Recessed Louvers in Masonry Walls

Model:
IWSRL-B

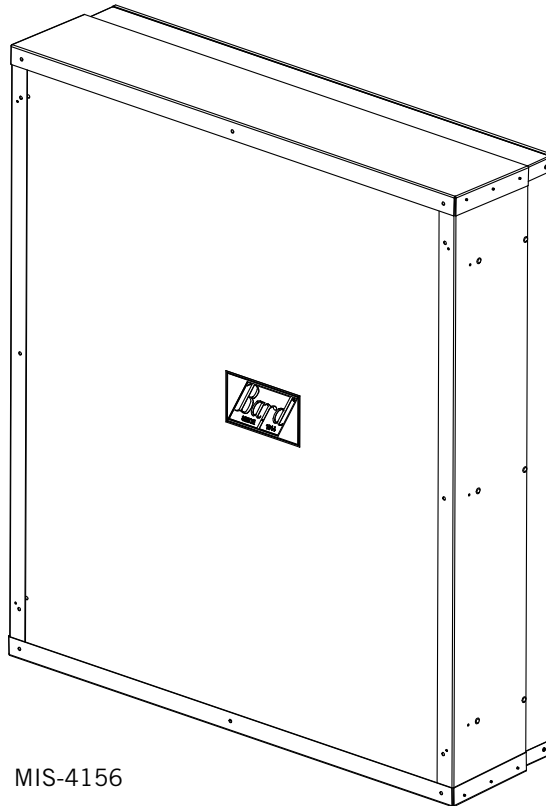

MIS-4156



Climate Control Solutions

Bard Manufacturing Company, Inc.
Bryan, Ohio 43506
www.bardhvac.com

Manual: 2100-747
Supersedes: **NEW**
Date: 6-16-20

CONTENTS

Getting Other Information and Publications ...2

I-TEC Wall Sleeve General Information3

- Shipping Damage 3
- General 3
- Unpacking 3

Installation6

- Masonry Construction Walls 6
- Attachment of Wall Sleeve to I-TEC Unit..... 7

Figures

- Figure 1 IWSRL-B Wall Sleeve Dimensions 4
- Figure 2 I-TEC and Wall Sleeve 5
- Figure 3 Masonry Construction Installation 6
- Figure 4 Typical Installation 7
- Figure 5 Attachment of Wall Sleeve 8

GETTING OTHER INFORMATION AND PUBLICATIONS

The following publications can help when installing the wall sleeve. They can usually be found at the local library or purchased directly from the publisher. Be sure to consult the current edition of each standard.

Standard for the Installation of Air Conditioning and Ventilating Systems.....ANSI/NFPA 90A

Standard for Warm Air Heating and Air Conditioning SystemsANSI/NFPA 90B

In addition, it may be helpful to consult the latest revision of I-TEC Installation Instructions manual 2100-549.

For more information, contact these publishers:

ACCA **Air Conditioning Contractors of America**
1712 New Hampshire Ave. N.W.
Washington, DC 20009
Telephone: (202) 483-9370
Fax: (202) 234-4721

ANSI **American National Standards Institute**
11 West Street, 13th Floor
New York, NY 10036
Telephone: (212) 642-4900
Fax: (212) 302-1286

ASHRAE **American Society of Heating, Refrigeration and Air Conditioning Engineers, Inc.**
1791 Tullie Circle, N.E.
Atlanta, GA 30329-2305
Telephone: (404) 636-8400
Fax: (404) 321-5478

NFPA **National Fire Protection Association**
Batterymarch Park
P.O. Box 9101
Quincy, MA 02269-9901
Telephone: (800) 344-3555
Fax: (617) 984-7057

I-TEC WALL SLEEVE GENERAL INFORMATION

Shipping Damage

Upon receipt of equipment, the carton should be checked for external signs of shipping damage. If damage is found, the receiving party must contact the last carrier immediately, preferably in writing, requesting inspection by the carrier's agent.

General

The IWSRL-B Series Wall Sleeve is designed for use with the I-TEC Series heat pump. The wall sleeve assembly consists of a large intake sleeve and a smaller exhaust sleeve. Both sleeves are telescoping to adjust for different wall depths. The wall sleeve is designed for use with 1" to 4" louver depths. As shipped, the sleeve is ready for 1" louver installation. See Figure 1 (page 4) and Figure 2 (page 5).

Wall Sleeve Model No.	Wall Thickness	Standard Louver Depth
IWSRL-B	8" – 13.5"	1"

These instructions explain the recommended method to install the wall sleeve. The equipment covered in this manual is to be installed by trained service and installation technicians.

These instructions and any instructions packaged with any separate equipment required to make the entire air conditioning system should be carefully read before beginning the installation.

While intended as a general recommended guide, these instructions do not supersede any national and/or local codes in any way. Authorities having jurisdiction should be consulted before the installation is made.

Unpacking

1. The smaller exhaust sleeve is attached to the weatherization plate with two (2) screws for shipping. Remove these screws (throw away) and set the exhaust sleeve assembly aside.
2. Remove the inner telescoping sleeve (with the rubber gasket) from larger inlet sleeve and set it aside.
3. Remove inlet sleeve, with weatherization plate attached, from the carton and turn over.
4. Remove and save the four (4) screws attaching the security plate.

FIGURE 1
IWSRL-B Wall Sleeve Dimensions

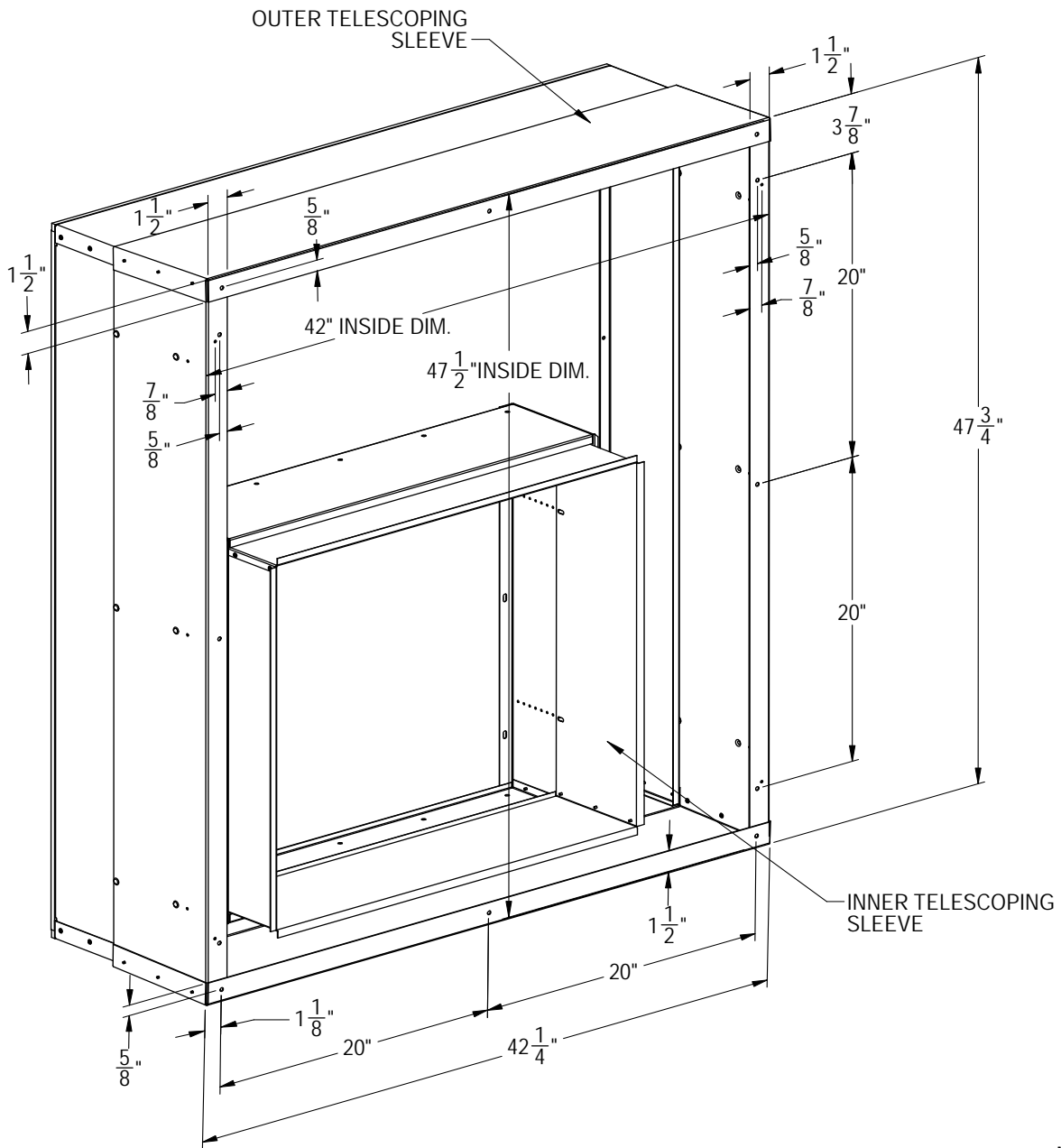

MIS-4157

FIGURE 2
I-TEC and Wall Sleeve

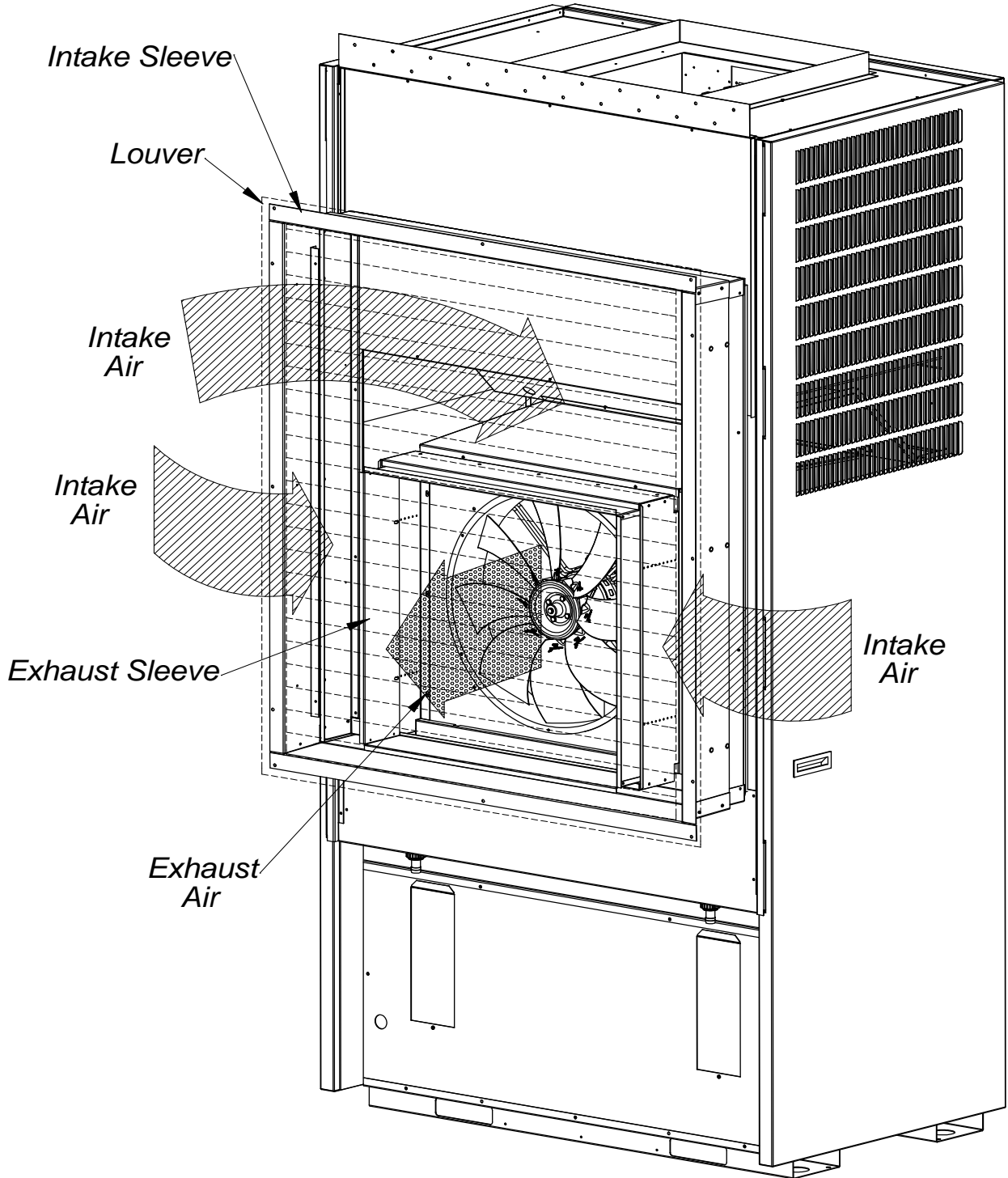

MIS-2931 B

INSTALLATION

Masonry Construction Walls

The IWSRL-B sleeve is meant to extend to the back of a recessed wall louver that is fastened directly to the masonry or brick wall (see Figure 3). The sleeve then extends to meet the back of the I-TEC unit. Sealant is used to form a water-tight seal between all sleeve parts.

It is important to note that the louver must have a means of allowing water to drain out of the sleeve area. A slope is built into the bottom of the sleeve. The slope will allow any water that enters the sleeve area to drain out through the louver.

Unit replacement applications may require user modification of the IWSRL-B. Modifications may include provisions for water drainage and also the ability to use existing wall louvers and openings.

Start the sleeve installation process by separating the two (2) pieces of the outer telescoping sleeve assembly.

The inner portion of the sleeve assembly will not be used currently and can be set off to the side.

Next, remove the weatherization plate from the outer telescoping sleeve assembly. The weatherization plate is attached to the outer sleeve surface that will be flush to the back of the recessed louver.

Install the sleeve assembly into the wall opening with the outer sleeve surface located where the back of the recessed wall louver will be. The outer sleeve surface is meant to be attached to the back of the recessed wall louver. Sealant must be used to join the outer sleeve and the louver to avoid leakage, while allowing water from the sleeve area to exit through the louver.

Insert the inner portion of the outer sleeve assembly and extend it to be 1/2" beyond the inner wall surface. The foam on the outer telescoping sleeve will be used to form a seal between the outer telescoping sleeve assembly and the I-TEC unit.

FIGURE 3
Masonry Construction Installation

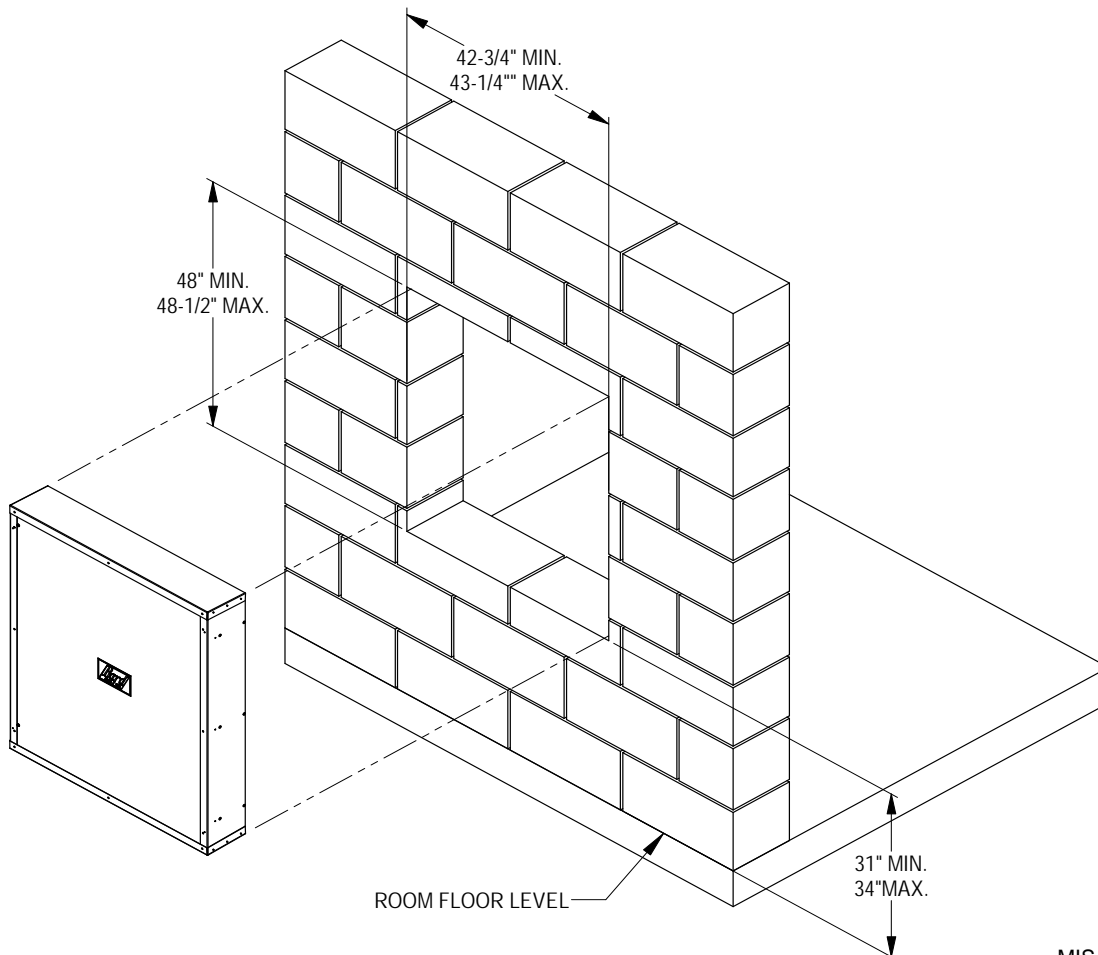

MIS-4158

NOTE: If foamed insulation is used, the final location of the inner sleeve must be determined since the foam insulation could lock the inner sleeve into an incorrect location causing either an air leak between sleeve and back of unit or preventing the unit from going as tight to the wall or sill as desired. This must be done before the unit is placed and before the inner portion of the intake sleeve is secured with screws to the outer sleeve. Insulating this space will prevent infiltration of any unwanted outside air (see Figure 4).

If the I-TEC unit will be drained through the wall, the drain line must be installed prior to setting the unit. Information for the drain installation is provided in the installation manual supplied with the unit.

At this point, the following are options:

1. Install the weatherization plate if the I-TEC unit is not ready to be installed.

NOTE: The exhaust sleeve attaches to the I-TEC unit. Store it and any remaining mounting hardware in a safe location.

2. Proceed with attachment of wall sleeve to I-TEC unit.

FIGURE 4
Typical Installation

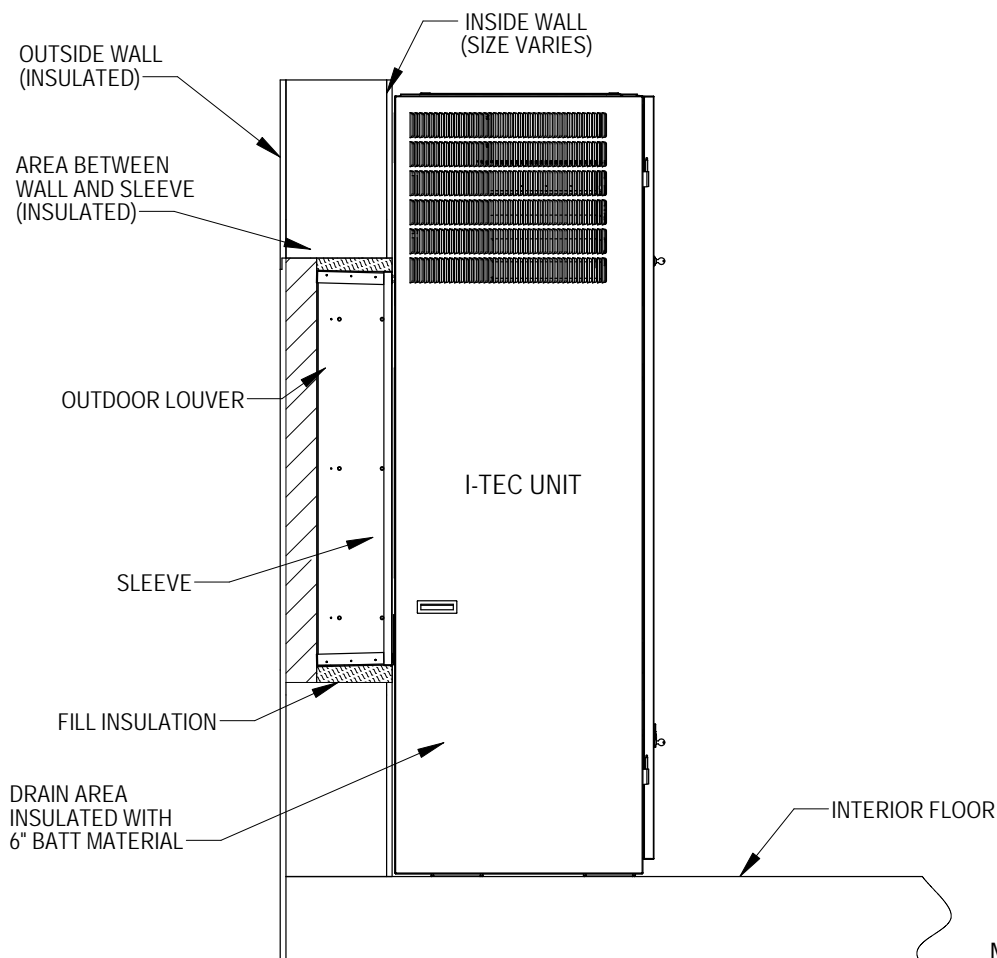

MIS-4159

Attachment of Wall Sleeve to I-Tec Unit

Move the unit into place ensuring it is aligned side to side. Push it back until the side panels are flush with the wall, or until the sides contact the window sill—if that is the case. From the outside of the building, push the inner sleeve inward until the foam gasket contacts the unit. Attach the sleeve to the rear of the I-TEC using

the twelve (12) $\frac{3}{4}$ " long self-tapping screws supplied with the sleeve. See Figure 5 on page 8, Ref. B.

Tie the inner and outer sleeves together with the three (3) $\frac{3}{4}$ " long self-tapping screws on each side (Figure 5, Ref. A). Apply a bead of caulk to the entire perimeter seam between the inner and outer sleeves (Figure 5, Ref. A).

The exhaust sleeve has three (3) screw slots in each side flange. Line these up with the screw engagement holes in the fan panel. Attach using six (6) 3/4" long sheet metal screws supplied with the sleeve (Figure 5, Ref. C). Extend the sleeve out until it is flush with

the louver attachment angles. Lock the sleeve in place using two (2) 1/2" long sheet metal screws on each side by shooting through the slot into a pre-punched hole (Figure 5, Ref. D).

FIGURE 5
Attachment of Wall Sleeve

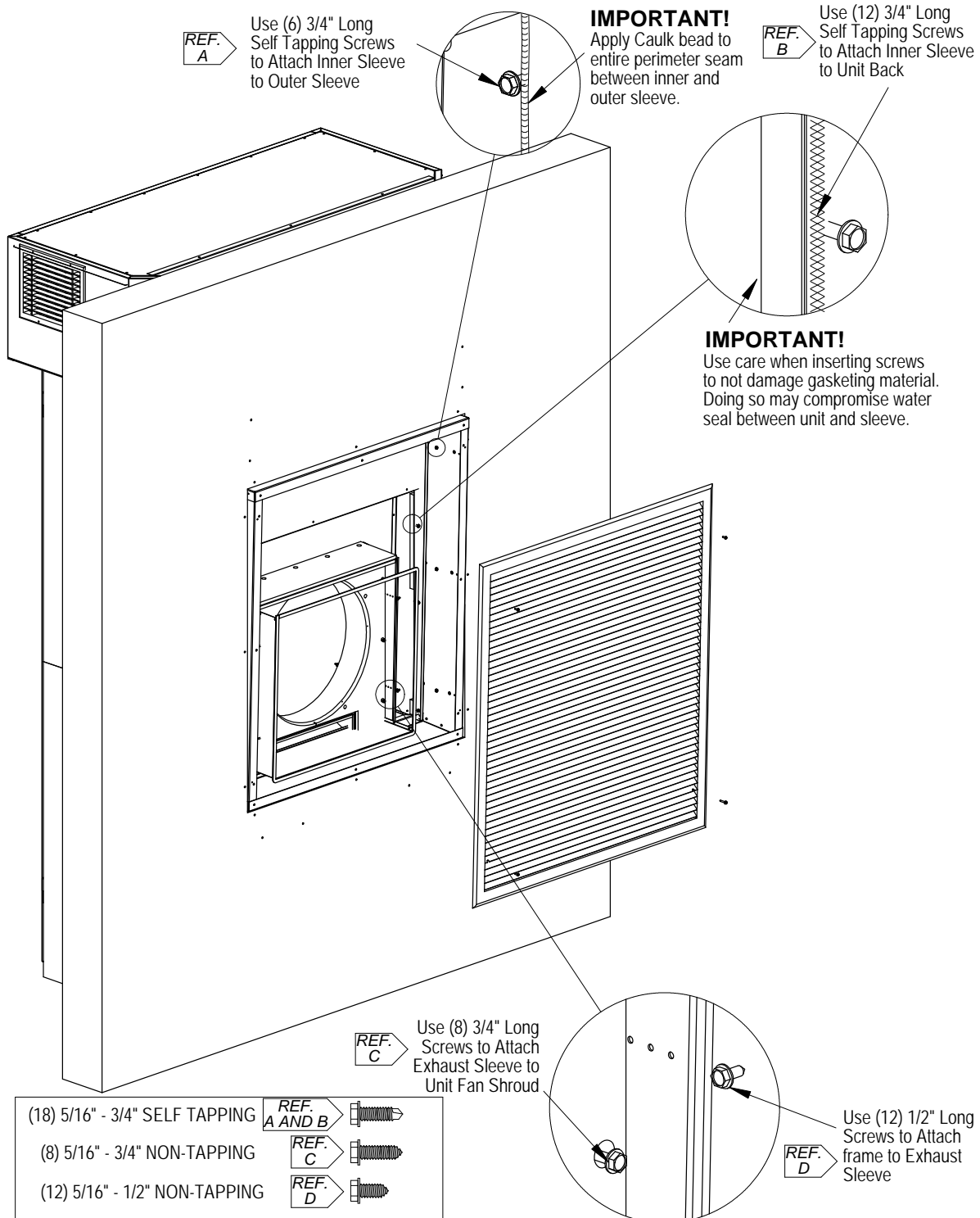

MIS-4160