

---

# SERVICE AND INSTALLATION INSTRUCTIONS WITH REPLACEMENT PARTS LIST

---

## LV1000-300 CONTROLLER



***NOTE: LV1000 controller is required for operation when FUSION-TEC® HR\*\*BP wall-mount units are used. Additional information regarding the installation and setup of the LV1000 controller and software is included in the system installation instructions shipped inside the wall-mount unit control panel.***



**Climate Control Solutions**

Bard Manufacturing Company, Inc.  
Bryan, Ohio 43506  
www.bardhvac.com

Manual : 2100-673J  
Supersedes: 2100-673I  
Date: 5-18-22

# CONTENTS

---

## **General Information .....4**

Air Conditioning System.....	4
Controller .....	4
LV1000-300 Series Controller and Accessories Included with Controller.....	4
Additional Publications.....	5

## **LV1000 Controller Installation.....6**

LV1000 Controller.....	7
Mounting the LV1000 Controller .....	7
LV1000 Supply Wiring .....	9
Installing Remote Indoor Sensor(s).....	10
Additional LV1000 Connections.....	12
Communication Wiring.....	13

## **Using the LV1000 Interface.....16**

LV1000 Controller Interface.....	16
System Interface Structure/ Menu Password Levels .....	16
Main Menu .....	17
Status Screen .....	17
Quick Menu .....	17
Setpoints .....	17
Information .....	18
System Information .....	18
System Demand.....	18
Shelter Last 24 Hours .....	18
Shelter Info.....	18
Software Info.....	18
Software Versioning Guide .....	19
Unit Information.....	19
Unit Main Status Screen Mirror..	19
Unit A/C Circuit Information.....	19
Unit Model/Serial Number/ Software Version .....	19
Unit Last 24 Hours Operation .....	20
Alarm Log .....	20
Changing to Celsius .....	20
Calibrating Sensors.....	20
Reset to Factory Defaults .....	20
Clear Alarm Logs .....	20
IP Configuration .....	21
Modbus TCP Configuration .....	21

## **Alarms .....22**

Alarm Adjustment .....	22
Acknowledging/Clearing Alarms.....	22
Sensor Failure Alarms .....	22
No Temperature Sensor Alarm .....	22
Temperature Alarms .....	22
Low Temperature Alarm .....	22
High Temperature Warning.....	23
High Temperature Alarm .....	23
Humidity Alarms .....	23
Low Humidity Alarm.....	23
High Humidity Alarm.....	24
Smoke Alarm .....	24
Hydrogen Alarm.....	25
Generator Alarm .....	25
Utility Power Loss Alarm .....	26

Inverter Failure Alarm .....	26
HVAC Fail Alarm.....	26
HVAC Maintenance Alarm.....	27
Anti-Theft Alarm.....	28

## **Control Operation .....29**

Temperature Control .....	29
Control Value Averaging.....	29
Comfort Mode .....	29
Emergency Vent.....	29
Emergency Cool.....	29
Cooling.....	29
Unit Rotation.....	29
Staging .....	31
Staging Type .....	31
Freecooling (Economizer) Operation .....	31
Heating .....	32
Humidity Control.....	32
Humidification .....	32
Humidifier Output.....	33
Dehumidification .....	33
Passive Dehumidification.....	33
Active Dehumidification.....	33
Fan Control .....	34
Hour Counting .....	34

## **Troubleshooting .....35**

8403-079 Remote Indoor Temperature/Humidity Sensor .....	35
Remote Indoor Temperature/Humidity Sensor Orientation.....	38

## **LV1000 Modbus TCP Register List .....39**

Input Registers (Read Only) .....	39
Holding Registers (Read/Write) .....	40
Discrete Inputs (Read Only) .....	41

## **LV1000 Replacement Parts .....45**

**FIGURES**

Figure 1 Typical LV1000 Component Location ..... 6  
 Figure 2 LV1000 Fused Power Supply Terminal .....7  
 Figure 3 LV1000 Controller Dimensional Drawing...8  
 Figure 4 V1000-300 Controller Supply Wiring .....9  
 Figure 5 Controller Grounding Posts .....9  
 Figure 6 Remote Indoor Temperature/Humidity Sensor Installation.....10  
 Figure 7 Additional Remote Sensor Installation .... 11  
 Figure 8 Communication Wiring: Termination at the Controller.....13  
 Figure 9 Communication Wiring (Daisy Chain) .....14  
 Figure 10 Communication Wiring (Alt. Method) .....14  
 Figure 11 Placement of Communication Filters .....15  
 Figure 12 LV1000 Controller Display and Interface ..16  
 Figure 13 Quick Menu Icons.....17  
 Figure 14 Enabling Comfort Mode.....18  
 Figure 15 System Demand .....18  
 Figure 16 Shelter Last 24 Hours.....18  
 Figure 17 Shelter Info.....18  
 Figure 18 Software Info .....18  
 Figure 19 Unit Main Status Screen Mirror.....19  
 Figure 20 Unit A/C Circuit Information .....19  
 Figure 21 Unit Model/Serial Number and Software Version .....19  
 Figure 22 Unit Last 24 Hours Operation .....20  
 Figure 23 Restoring Factory Default Settings.....20  
 Figure 24 Clearing LV1000 Alarm Logs .....20  
 Figure 25 IPv4 Configuration .....21  
 Figure 26 Modbus TCP Setup .....21  
 Figure 27 Clearing All Alarms .....22  
 Figure 28 Adjusting Temperature Alarm Setpoints ..22  
 Figure 29 Adjusting Humidity Alarm Setpoints .....23  
 Figure 30 Changing Smoke Input Values.....24  
 Figure 31 Changing Smoke Alarm Configuration .....25  
 Figure 32 Adjusting Units Running When Generator is Active .....26  
 Figure 33 Adjusting Economizers Running When Generator is Active .....26  
 Figure 34 Changing HVAC Fail Alarm Output .....27  
 Figure 35 Changing HVAC Fail Alarms .....27  
 Figure 36 Changing HVAC Maintenance Alarms.....28  
 Figure 37 Adjusting Setpoints .....29  
 Figure 38 Adjusting Unit Rotation Parameters.....30  
 Figure 39 Adjusting Unit Staging.....31  
 Figure 40 Economizer Setup .....32  
 Figure 41 Adjusting Humidifiers Settings.....33  
 Figure 42 Changing Humidifier Output Direction ....33  
 Figure 43 Adjusting Dehumidification Setpoints .....34  
 Figure 44 Adjusting Continuous Fan Setting .....34  
 Figure 45 Last 24 Hours Tracking .....34  
 Figure 46 8403-079 Sensor.....35  
 Figure 47 Current Sensor Orientation .....38  
 Figure 48 Earlier Sensor Orientation.....38  
 Figure 49 LV100-300 Wiring Diagram .....44  
 Figure 50 PLC Core Style Identification .....46

**TABLES**

Table 1 LV1000 Passwords (Defaults) .....17  
 Table 2 LV1000 System Status Messages.....17  
 Table 3 Software Versioning Guide .....19  
 Table 4 Modbus Unit of Measure (UOM) Values...21  
 Table 5 Temperature and Humidity Sensors .....22  
 Table 6 Staging.....30  
 Table 7 8403-079 Sensor: Temperature/Humidity .....36  
 Table 8 8403-079 Sensor: Voltage/Humidity .....37  
 Table 9 LV1000-300 Terminal Block Index.....43

**IMPORTANT**

*When connecting this product from a remote location, ensure that the network connection is secure and reliable.*

**NOTICE**

*It is important to check the software version during installation to ensure that the latest version has been installed. Current software versions and installation instructions are available on the Bard website at <http://www.bardhvac.com/software-download/>.*

# GENERAL INFORMATION

## Air Conditioning System

This Bard air conditioning system is composed of FUSION-TEC HR Series wall-mount air conditioners matched with an LV1000 first on/next on controller. The wall-mount units are specifically engineered for telecom/motor control center rooms.

**NOTE:** *The LV1000 controller and FUSION-TEC HR Series wall-mount units are designed specifically to work together. The LV1000 controller cannot run other Bard models or other brands of systems. They are a complete system, and must be used together.*

## Controller

LV1000 controller and accessories included are shown below.

# NOTICE

***It is important to check the software version during installation to ensure that the latest version has been installed. Current software versions and installation instructions are available on the Bard website at <http://www.bardhvac.com/software-download/>.***

### LV1000-300 Series Controller and Accessories Included with Controller



(1) LV1000 Programmable Logic Controller



(1) TEC-EYE™ Hand-Held Diagnostic Tool  
Bard P/N 8301-059



(1) Remote Temperature/Humidity Sensor<sup>1</sup>  
Bard P/N 8403-079



(1) 35' 5-Wire 18 Gauge Shielded Cable



(2) Communication EMI Filters  
Bard P/N 8301-055

### Optional Sensors:



Remote Temperature/Humidity Sensor<sup>1</sup>  
Bard P/N 8403-079



Remote Temperature Only Sensor  
Bard P/N 8301-058

<sup>1</sup> One remote temperature/humidity sensor is included with the LV1000 controller. Up to two additional remote temperature/humidity sensors can be purchased and installed. Temperature-only sensors (Bard P/N 8301-058) may be used instead of the additional temperature/humidity sensors, but will also need to be purchased separately. Temperature-only sensors require field-supplied 2-wire shielded cable.

The equipment covered in this manual is to be installed by trained, experienced service and installation technicians.

These instructions should be carefully read before beginning the installation. Note particularly any tags and/or labels attached to the equipment.

While these instructions are intended as a general recommended guide, they do not supersede any national and/or local codes in any way. Authorities having jurisdiction should be consulted before the installation is made. See **Additional Publications** for information on codes and standards.

### Shipping Damage

Upon receipt of equipment, the cartons should be checked for external signs of shipping damage. If damage is found, the receiving party must contact the last carrier immediately, preferably in writing, requesting inspection by the carrier's agent.

### Additional Publications

These publications can help when installing the air conditioning system. They can usually be found at the local library or purchased directly from the publisher. Be sure to consult the current edition of each standard.

National Electrical Code .....	ANSI/NFPA 70
Standard for the Installation of Air Conditioning and Ventilating Systems .....	ANSI/NFPA 90A
Standard for Warm Air Heating and Air Conditioning Systems .....	ANSI/NFPA 90B
Load Calculation for Residential Winter and Summer Air Conditioning .....	ACCA Manual J
Duct Design for Residential Winter and Summer Air Conditioning and Equipment Selection .....	ACCA Manual D

For more information, contact these publishers:

**Air Conditioning Contractors of America (ACCA)**  
1712 New Hampshire Ave. N.W.  
Washington, DC 20009  
Telephone: (202) 483-9370 Fax: (202) 234-4721

**American National Standards Institute (ANSI)**  
11 West Street, 13th Floor  
New York, NY 10036  
Telephone: (212) 642-4900 Fax: (212) 302-1286

**American Society of Heating, Refrigeration and Air Conditioning Engineers, Inc. (ASHRAE)**  
1791 Tullie Circle, N.E.  
Atlanta, GA 30329-2305  
Telephone: (404) 636-8400 Fax: (404) 321-5478

**National Fire Protection Association (NFPA)**  
Batterymarch Park  
P. O. Box 9101  
Quincy, MA 02269-9901  
Telephone: (800) 344-3555 Fax: (617) 984-7057

### ANSI Z535.5 Definitions:

**DANGER:** Indicate[s] a hazardous situation which, if not avoided, will result in death or serious injury. The signal word "DANGER" is to be limited to the most extreme situations. DANGER [signs] should not be used for property damage hazards unless personal injury risk appropriate to these levels is also involved.

**WARNING:** Indicate[s] a hazardous situation which, if not avoided, could result in death or serious injury. WARNING [signs] should not be used for property damage hazards unless personal injury risk appropriate to this level is also involved.

**CAUTION:** Indicate[s] a hazardous situation which, if not avoided, could result in minor or moderate injury. CAUTION [signs] without a safety alert symbol may be used to alert against unsafe practices that can result in property damage only.

**NOTICE:** [this header is] preferred to address practices not related to personal injury. The safety alert symbol shall not be used with this signal word. As an alternative to "NOTICE" the word "CAUTION" without the safety alert symbol may be used to indicate a message not related to personal injury.





# LV1000 CONTROLLER INSTALLATION

FIGURE 1  
Typical LV1000 Component Location

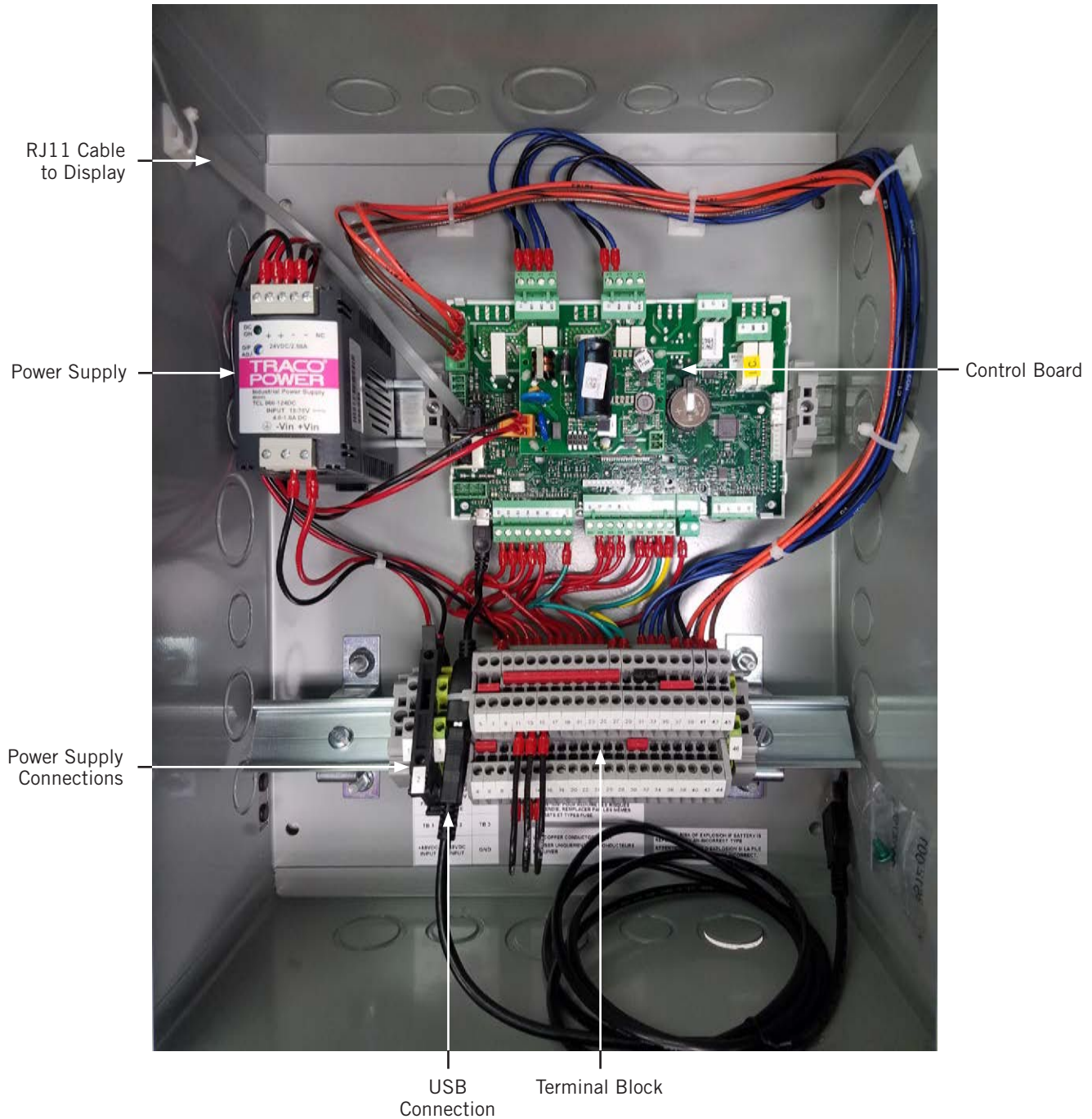

# **WARNING**

**Electrical shock hazard.**

**Disconnect VAC and VDC power supplies before servicing.**

**Failure to do so could result in electric shock or death.**

**IMPORTANT:** *When working with circuit board components, Bard recommends the use of an anti-static wrist strap to prevent static electricity shorts to electronic controls.*

## **LV1000 Controller**

The LV1000 controller is part of this Bard air conditioning system. It is used to control up to four (4) wall-mount air conditioners from one controller. The microprocessor control provides an easy-to-read interface with large LCD graphical display. It provides control for redundancy for the structure and equal wear on all units. The LV1000 controller is configured for first on/next on sequence.

**Conduit is recommended for all wiring. Route communication wiring and power supply wiring in their own separate conduits.**

**The LV1000 controller is not weatherproof and is intended for use in weathertight structure.**

## **Mounting the LV1000 Controller**

The dimensions of the LV controller are 16" by 12" by 6".

Because the LV1000 controller utilizes a remote temperature sensor as opposed to one located in the controller box, the controller itself can be installed in any indoor location that is suitable, preferably at eye level. Four (4) mounting holes are provided for mounting to the wall. Use mounting hardware capable of holding the weight of the controller such as 1/4" diameter fasteners with flat washers that are 1" outside diameter (OD). Knockouts provided on the base, sides and top of the controller can be used for conduit connections (see Figure 3 on page 8).

Ground case before doing any work or do not connect power (48VDC) to unit until earth ground is connected.

The LV1000 controller includes a fused power supply terminal in the terminal block. Before connecting wires to the terminal block, confirm that the fuse in the fuse holder is in the proper position (active) as shown in Figure 2.

**FIGURE 2**  
**LV1000 Fused Power Supply Terminal**

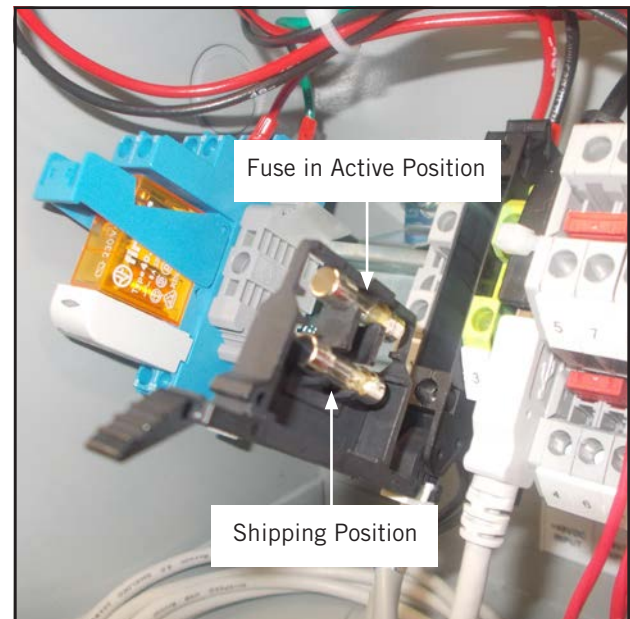

**FIGURE 3**  
**LV1000 Controller Dimensional Drawing**

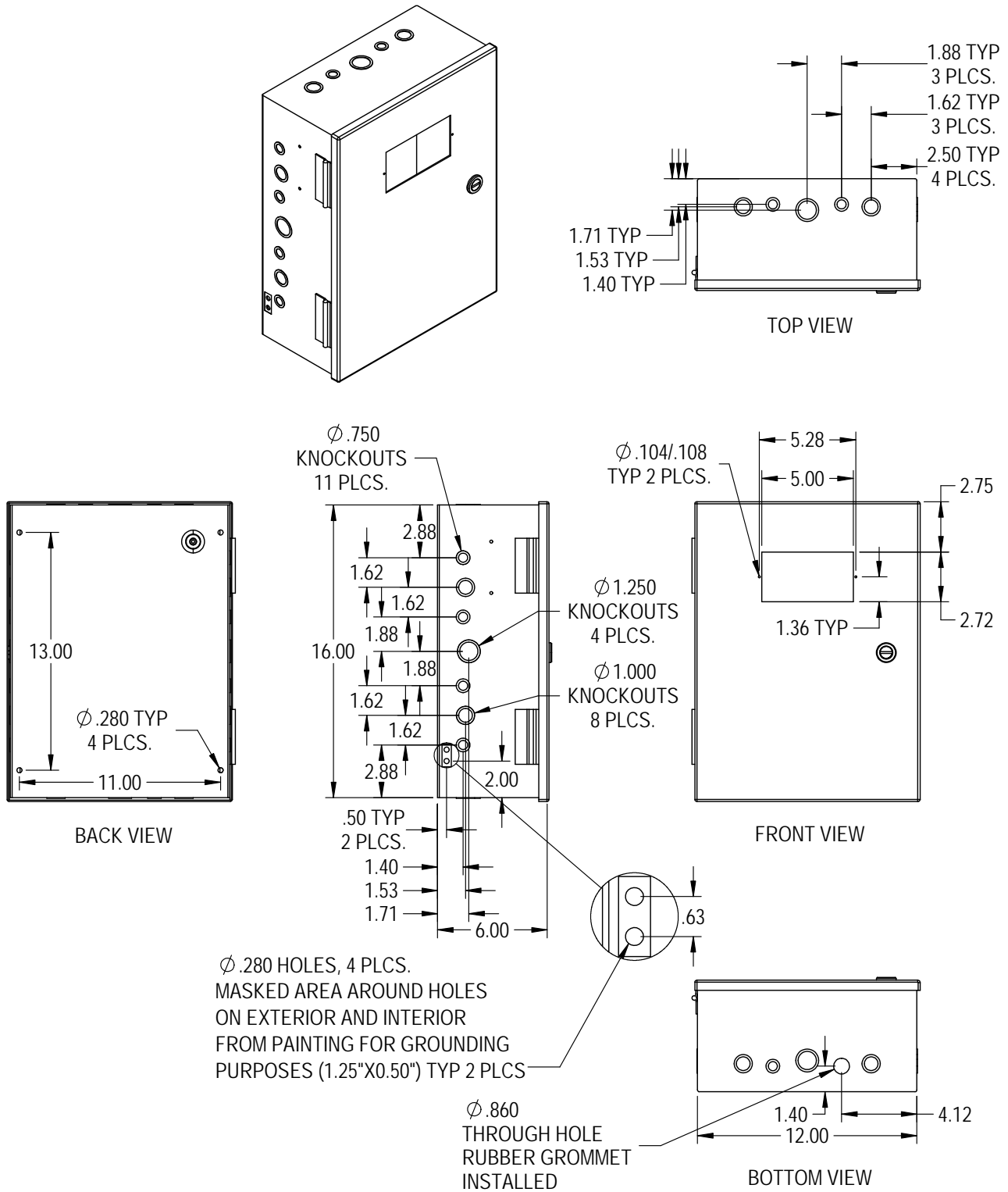

MIS-4384



## LV1000 Supply Wiring

The LV1000 controller is powered by -48VDC from the shelter. A field-supplied 5 amp DC circuit breaker is required. Field-supplied supply wiring should be minimum 16 gauge, maximum 14 gauge (see Figure 4). A reliable earth ground must be connected in addition to any grounding from conduit. Grounding bolts and nuts are included with the controller for this purpose; a 2 hole grounding lug must be field supplied. Install as shown in Figure 5. **Failing to ground the controller box properly could result in damage to the equipment.**

**FIGURE 4**  
**LV1000-300 Controller Supply Wiring**

The controller requires a separate -48VDC power supply, an additional 5-amp DC breaker (field supplied) and minimum 16 gauge supply wire.

-48VDC termination at controller: Bring the -48VDC power supply wires through conduit to the controller box. Land the positive (+) 48VDC wire to terminal #1 and the negative (-) 48VDC wire to terminal #2.



**NOTE:** *If the DC wiring is not terminated correctly on the specific polarity-indicated terminals of the block, the controller will not activate and will not function. Verify polarity of connections and wait to initialize controller until "system start up."*

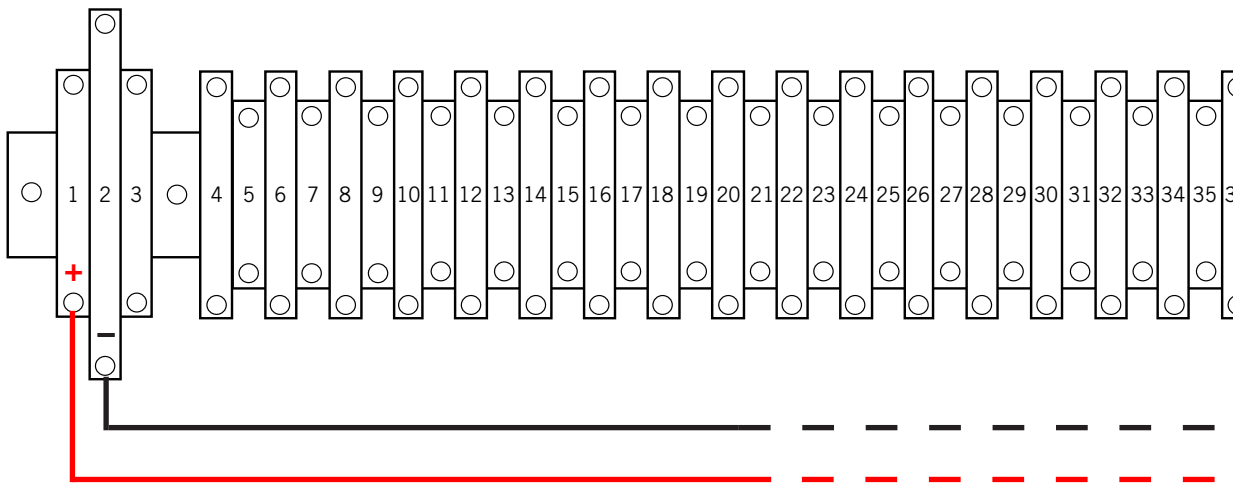

**FIGURE 5**  
**Controller Grounding Posts**

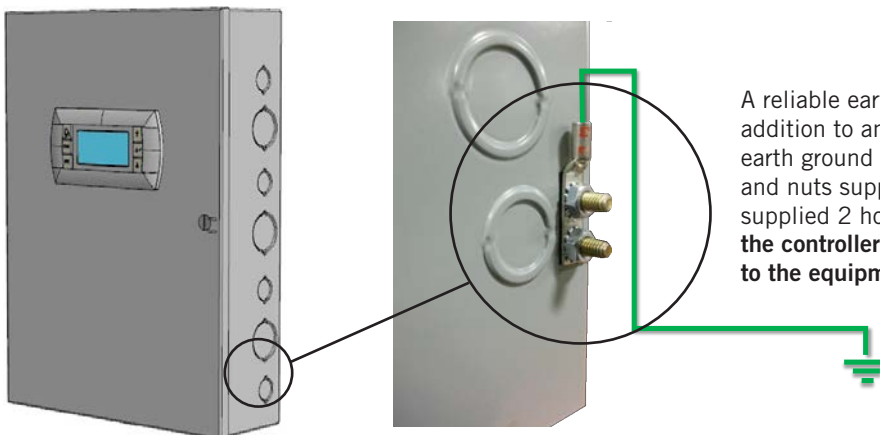

A reliable earth ground must be connected in addition to any grounding from conduit. Attach earth ground to side of controller box using bolts and nuts supplied with controller and field-supplied 2 hole grounding lug. **Failing to ground the controller box properly could result in damage to the equipment or personal injury.**

## Installing Remote Indoor Temperature/Humidity Sensor(s)

One remote indoor temperature/humidity sensor and 35' of 18 gauge 5-conductor shielded cable is included with the controller. This sensor must be installed for proper operation. Mount the temperature/humidity sensor in a location least likely to be affected by open doors, rack-mounted fans, radiant heat sources, etc. Location height should be approximately 60" above the floor. The sensor should be installed on a 2" x 4" junction box to allow for control wire conduit (see Figure 6). Use shielded cable to connect to controller. The maximum cable length to connect the temperature/humidity sensor to the LV1000 is 98'.

**FIGURE 6**  
**Remote Indoor Temperature/Humidity Sensor Installation**

1. Connect wires from the 18 gauge shielded cable to LV1000 terminals #24, #25, #18, #19 and #30.

LV1000 TB#	Sensor	Description	Wire Mark
24	NTC OUT	Indoor Temperature 1	B6
25	NTC OUT	Ground	GND
18	OUT H	Indoor Humidity 1 Signal: 0-1 VDC	B2
19	M (G)	Indoor Humidity 1 Common	GND
30	+ (G)	Indoor Humidity 1 Power	+VDC

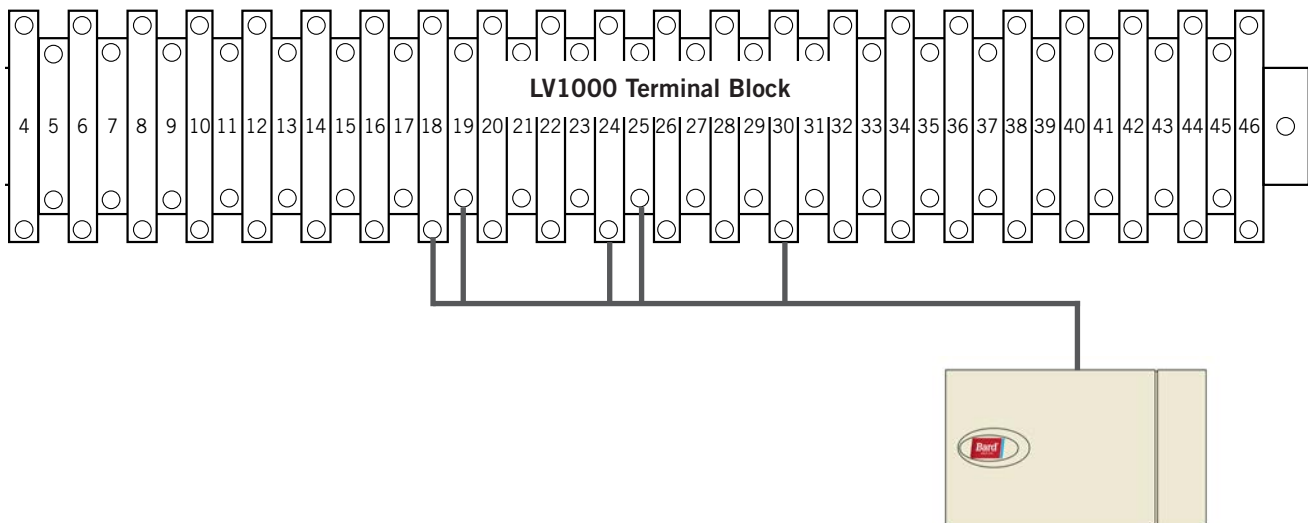

2. Connect the other end of the shielded cable to the sensor terminals. Be sure wires are connected to proper terminals as shown in table above.

**Sensor jumpers need to be positioned for 0-1 V.** With sensor oriented as shown in image to right, move both jumpers to right position (DP1 and DP2 set to OFF). **This applies to all indoor temperature/humidity sensors connected to the LC controller.** See illustration mounted inside of sensor cover for further detail on jumper position.

**Earlier versions of this sensor may be mounted in a different orientation which would affect the positioning of the sensor jumpers.** See page 38 for additional information on sensor orientation.

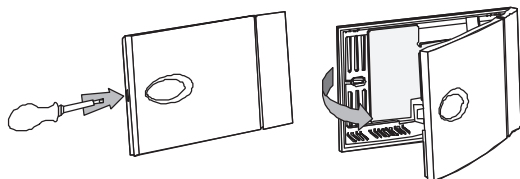
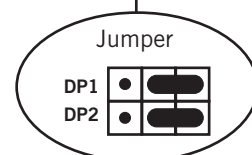
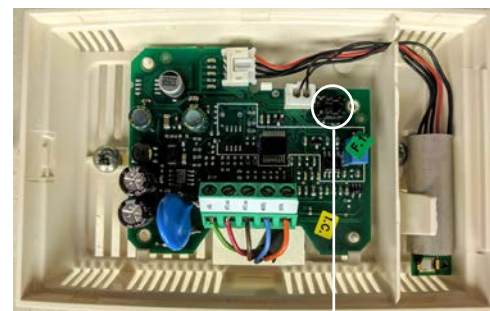

For proper operation, the remote indoor temperature/humidity sensor (and any additional sensors) must be configured properly with the controller as shown in Step 2 on page 10. Up to two additional temperature and humidity sensors can be purchased and installed. Alternately, temperature-only sensors can be purchased and installed instead of the combination sensors. All installed sensors must be enabled in the controller menu (see **Configure Sensors** in system installation instructions included with the wall-mount unit). Use shielded cable to connect additional sensors to controller.

**FIGURE 7**  
**Additional Remote Temperature and Temperature/Humidity Sensor Installation**

Up to two additional temperature/humidity sensors may be added. **Be sure the sensors are connected to the proper terminals on the terminal block and sensor as listed below.** See page 10 for information on correct sensor jumper position. The maximum cable length to connect temperature or temperature/humidity sensors to the LV1000 is 98'.

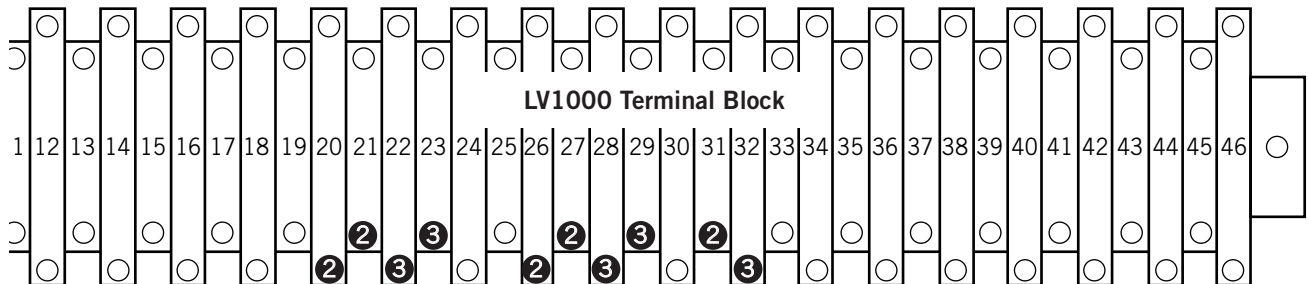

**2**  
**Optional Remote Temperature/Humidity Sensor**  
 Terminals 26, 27, 20, 21 & 31

LV1000 TB#	Sensor	Description	Wire Mark
26	NTC OUT	Indoor Temperature 2	B7
27	NTC OUT	Ground	GND
20	OUT H	Indoor Humidity 2 Signal: 0-1 VDC	B3
21	M (G)	Indoor Humidity 2 Common	GND
31	+ (G)	Indoor Humidity 2 Power	+VDC

**3**  
**Optional Remote Temperature/Humidity Sensor**  
 Terminals 28, 29, 22, 23 & 32

LV1000 TB#	Sensor	Description	Wire Mark
28	NTC OUT	Indoor Temperature 3	B8
29	NTC OUT	Ground	GND
22	OUT H	Indoor Humidity 3 Signal: 0-1 VDC	B4
23	M (G)	Indoor Humidity 3 Common	GND
32	+ (G)	Indoor Humidity 3 Power	+VDC

Temperature-only sensors can be used in place of the additional temperature/humidity sensors. #2 temperature-only sensor will connect to TB# 26 and 27. #3 temperature-only sensor will connect to TB# 28 and 29. The wire connections for the temperature-only sensors are not polarity sensitive.

### Additional LV1000 Connections

There are factory-installed jumpers across terminals #10 and #11 (hydrogen detector), #12 and #13 (generator run) and #14 and #15 (anti-theft device). Remove the factory-installed jumpers before connecting to the hydrogen detector, generator and/or anti-theft device (if applicable).

INPUTS				
	LV1000 Connections		Sensor Connections	Description
	Wire Mark	Terminal	Terminal	
Smoke	DI1	8	Varies	Smoke Detector Input
	GND	9		Ground
Hydrogen	DI2	10		Hydrogen Detector Input
	GND	11		Ground
Generator	DI3	12		Generator Run Input
	GND	13		Ground
Anti-Theft	DI4	14	9 (BG1000)	Anti-Theft Device
	GND	15	10 (BG1000)	Ground

OUTPUTS				
	LV1000 Connections		External Connections	Description
	Wire Mark	Terminal	Terminal	
Humidifier	NO1	34	Varies	Humidifier Output
	C1	35		Common
HVAC Fail	NO2	36		Alarm Relay – HVAC Fail
	C1	37		Common
HVAC Maintenance	NO3	38		Alarm Relay – HVAC Maintenance
	C1	39		Common
Anti-Theft	NO4	40	Alarm Relay – Anti-Theft	
	C4	41	Common	

COMMUNICATIONS				
	LV1000 Connections		External Connections	Description
	Wire Mark	Terminal	Terminal	
Fieldbus 1*	FB-1 (-)	42	2	Wall Unit Daisy Chain
	FB-1 (+)	43	1	Wall Unit Daisy Chain
Fieldbus 2*	FB-2 (-)	44	-	-
	FB-2 (+)	45	+	-
Ground	FB-2 (-)	46	Drain	Drain for Daisy Chain

\* Polarity Sensitive

## Communication Wiring

The steps outlined on the following pages show how to connect the communication wiring to the LV controller. See the system installation instructions included with the wall-mount unit for information on connecting the communication wiring to the wall-mount unit(s).

**FIGURE 8**  
**Communication Wiring: Termination at the Controller**

1. Using the field-provided shielded cable, make a small service loop after entering the controller and attach the provided EMI filter at the intersection of the loop.

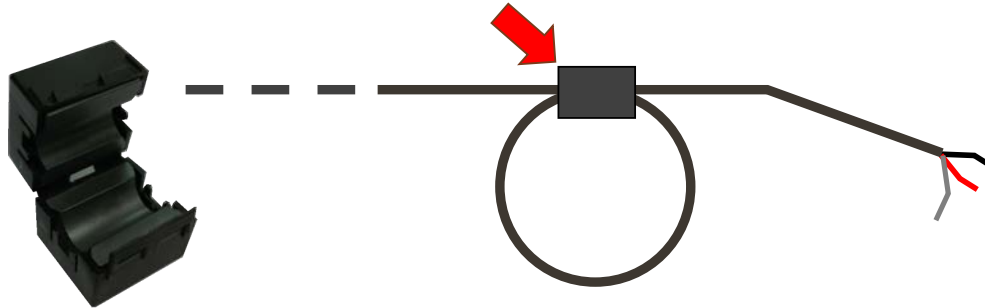

2. Connect one wire to terminal #42 (NEGATIVE), the other wire to terminal #43 (POSITIVE) and the drain wire to ground terminal #46.

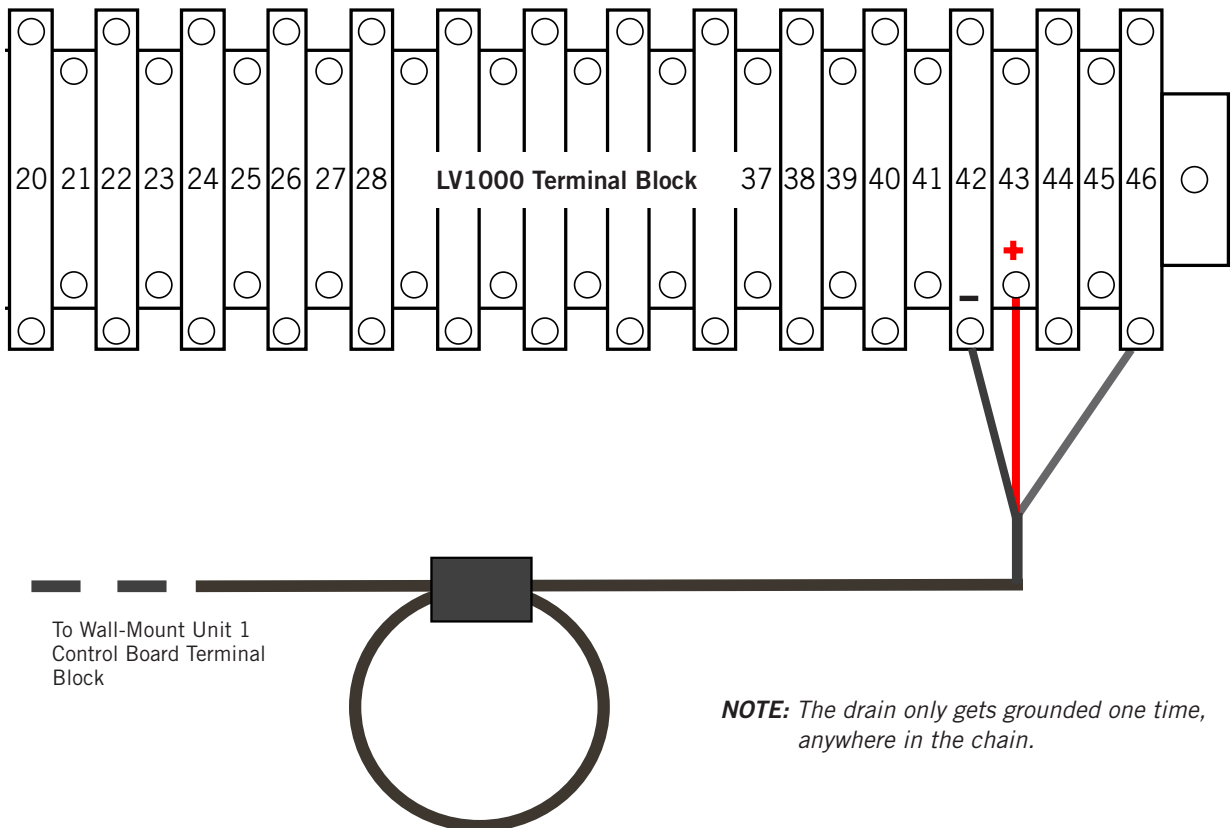

Connect the communication wiring from the controller to the wall-mount units in the manner shown in Figures 9, 10 or 11. **The daisy chain does not need to follow the addressing order.** The communication wire should be 2-wire, 18 gauge shielded cable with drain. Any color can be used. Be sure to match "+" and "-" symbols on controller terminal blocks to prewired unit control terminal block. Attach communication wire filters as shown in Figures 9, 10 or 11. Filters go inside the unit or controller box; they are shown out of unit for identification purposes only. **Do not run communication wiring in same conduit as supply wiring. Route communication wiring and power supply wiring in their own separate conduits.**

**FIGURE 9**  
**Communication Wiring (Daisy Chain Method)**

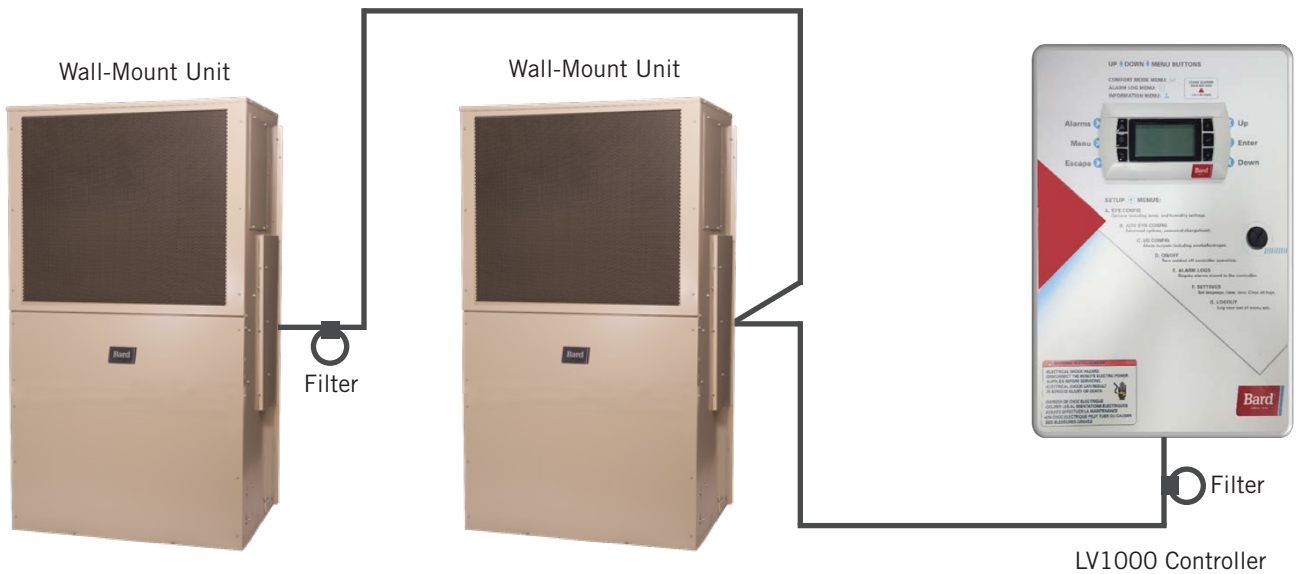

In addition to the "daisy chain" method of connecting the communication wiring shown in Figure 9, the wall-mount units can also be connected in the manner shown in Figure 10. If connecting wall units this way, be sure to place the communication wire filters in the positions shown in Figure 10. See Figure 11 for more information on the correct placement of the communication wire filters depending on the wiring method used.

**FIGURE 10**  
**Communication Wiring (Alternate Method)**

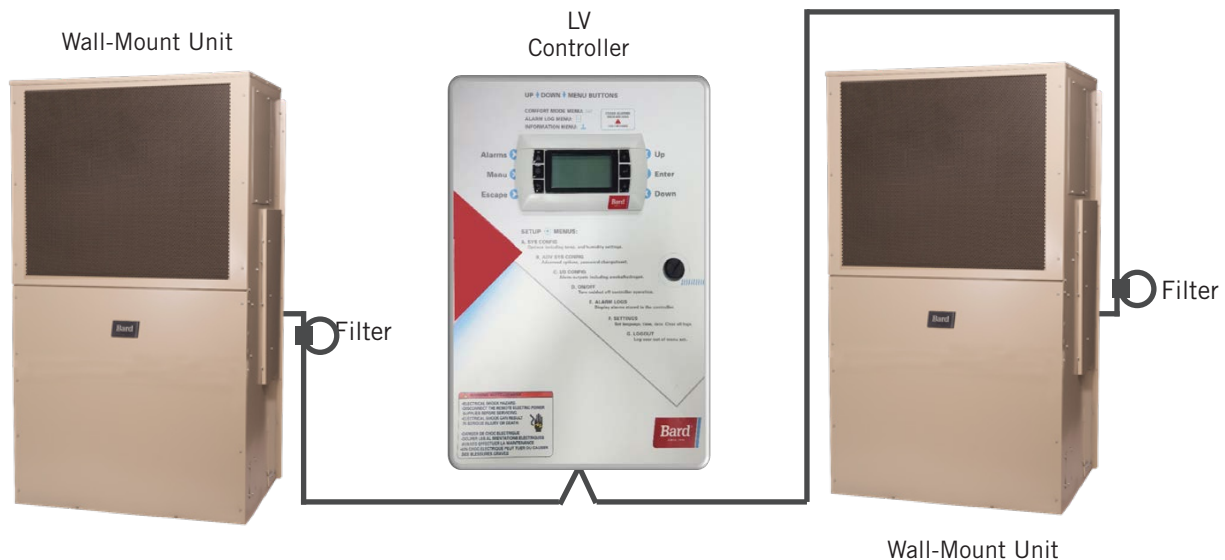



**FIGURE 11**  
**Placement of Communication Wire Filters (Daisy Chain and Alternate Methods)**



**NOTE:** Line filters can be on either the unit or controller, whichever device is on the end of the chain. No matter how many units there are, the two end devices will only have ONE communication cable, whereas the center devices will all have TWO (as shown above). Filters go inside the unit or controller; shown out of unit above for identification only.

# USING THE LV1000 INTERFACE

FIGURE 12  
LV1000 Controller Display and Interface (Status Screen Shown)



**ALARM KEY**  
Allows viewing of active alarms  
Silences audible alarms  
Resets active alarms

**MENU KEY**  
Allows entry to Main Menu

**ESCAPE KEY**  
Returns to previous menu level  
Cancels a changed entry

**UP KEY**  
Steps to next screen in the display menu  
Changes (increases) the value of a modifiable field

**ENTER KEY**  
Accepts current value of a modifiable field  
Advances cursor

**DOWN KEY**  
Steps back to previous screen in the display menu  
Changes (decreases) the value of a modifiable field

## LV1000 Controller Interface

The microprocessor control used in the FUSION-TEC HR Series wall-mount air conditioners allows for complete control and monitoring through the use of the LV1000 controller. These controllers utilize the latest in state-of-the-art technology including a large, easy-to-read backlit LCD graphic display.

The menu driven interface provides users the ability to scroll through two menu levels: Quick Menu and Main Menu. The menus permit the user to easily view, control and configure the unit.

The controller is completely programmed at the factory; therefore, most applications will require no field set-up. However, the default setpoints and their ranges are easily viewed and adjusted from the controller display. The program and operating parameters are permanently stored on FLASH-MEMORY in case of power failure. The controller is designed to manage temperature levels to a user-defined setpoint via control output signals to the wall-mount air conditioning system.

**NOTE:** Screenshots shown in this manual reflect default settings (when applicable).

## System Interface Structure/Menu Password Levels

### Quick Menu

Setpoints (Comfort Mode)

Information

System Information

Unit 1 Information

Unit 2 Information (when configured)

Unit 3 Information (when configured)

Unit 4 Information (when configured)

Alarm Log

### Main Menu

System Configuration: A1-A10 User (2000)

Adv. System Config: B1-B4 Technician (1313)

I/O Configuration: C1-C18 Technician (1313)

On/Off: User (2000)

Alarm Log: User (2000)

Settings

Date/Time: Technician (1313)

Language: User (2000)

Network Configuration

IPV4: Technician (1313)

Modbus TCP Config: Technician (1313)

Import/Export: User (2000)

Initialization: User (2000)

Change Passwords

Logout

In addition to the menu structure above, there are also Status and Alarm screens.

**TABLE 1**  
**LV1000 Passwords (Defaults)**

User	2000
Technician	1313
Engineer	9254
Use UP or DOWN keys and ENTER key to enter password	

**Main Menu**

Press the MENU key from any screen to return to the Main Menu. Press the UP or DOWN keys to scroll through the available menus. When the desired menu is highlighted, press the ENTER key to access that menu. Press the ESCAPE key or MENU key to return to the Status screen from the Main Menu.

**Status Screen**

The Status screen is the default start-up screen and also the return screen after 5 minutes of no activity. The screen can be accessed any time by pressing the ESCAPE key repeatedly. The LV1000 Status screen displays the current date and time, indoor room conditions and system status. See Table 2 for LV1000 system status messages.

The Quick Menu is available on the Status screen. Use UP or DOWN keys while on the Status screen to scroll between the three Quick Menu options (see Figure 13); press ENTER key when the desired icon is displayed.

**FIGURE 13**  
**Quick Menu Icons**

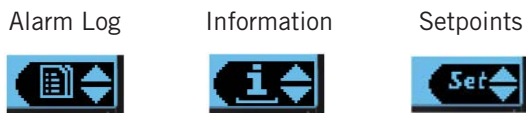

**Quick Menu**

**Setpoints**

The Setpoints quick menu allows for a technician in the shelter the ability to set up, enable or disable comfort mode.

To enable comfort mode:

1. From the Status screen, press UP or DOWN key until Quick Menu displays Setpoints icon. Press ENTER key.
2. Press ENTER key to scroll to the Comfort Mode (see Figure 14 on page 18).
3. Press UP or DOWN key to change value from **OFF** to **ON**.
4. Press ENTER key to save.
5. Press ESCAPE key until Main Menu screen is displayed.

**TABLE 2**  
**LV1000 System Status Messages**

Message	Description
Waiting...	POC is on and has not started the application yet.
Freecooling	System is actively economizing.
Cooling	System is actively mechanical cooling.
Optomized Cool	System is mechanical cooling while actively economizing.
Heating	System is actively heating.
Passive Dehum	System is taking measures to decrease humidity without using extra energy.
Active Dehum	System is taking active measures to decrease humidity.
Power Loss	Unit(s) in system have suffered a power loss.
Inverter Mode	System is operating on inverter power.
Off by Alarm	System has major fault preventing operation.
Off by BMS	System has been turned off from BMS system.
Off by Keypad	System has been turned off by local user.
Unit in Test	Unit(s) in system are currently conducting a self test.
Override Active	There is an active override on the system.
Comfort Mode	System is operating in Comfort Mode.
Emergency Vent	Unit is in Emergency Ventilation. System has active hydrogen alarm.
Emergency Cool	System is in Emergency Cooling. Indoor temperatures have exceeded high temp alarm.
Emergency Off	System is in Emergency Off. System has an active smoke alarm.

**FIGURE 14**  
Enabling Comfort Mode

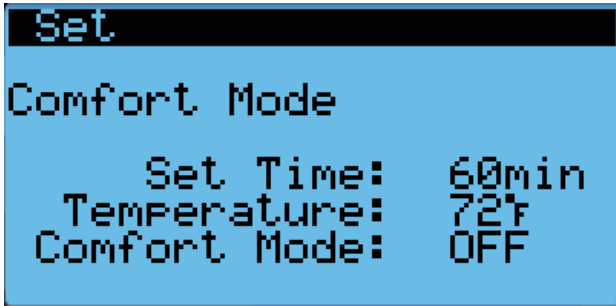

**Information**

The Information quick menu displays system and unit status information for all devices attached to the system. The info display is broken up into two menu types (system information and unit information). The number of unit information menu items available will depend on the number of units the LV1000 is set up to command.

System Information

The System Information menu displays the following information: system demand, system last 24 hour run times, system last hour averages (indoor temperature, indoor humidity, outdoor temperature and outdoor humidity) and software version information.

System Demand

The System Demand screen displays the current demand that is required from the system to heat or cool the indoor space. Each function of the system has a separate demand that is displayed in the upper portion of the display (see Figure 15). The lower half of the display indicates each output stage that is to be called on for each unit. It will also display **No Device** if a specific unit is not connected. When functions like freecooling or heating are not available, this area will display "--" for that specific unit.

**FIGURE 15**  
System Demand

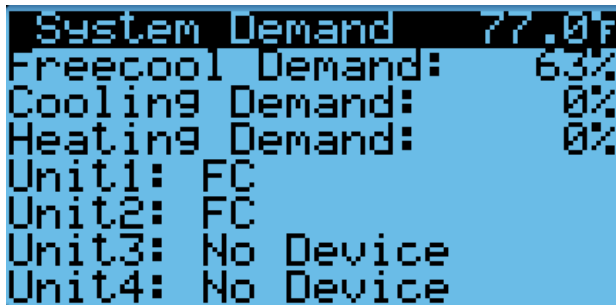

*Shelter Last 24 Hours*

Last 24 hour operation information tracks the run times (**Run**) and start calls (**ST**) of different NOC output alarms in the last 24 hour period (see Figure 16).

**FIGURE 16**  
Shelter Last 24 Hours

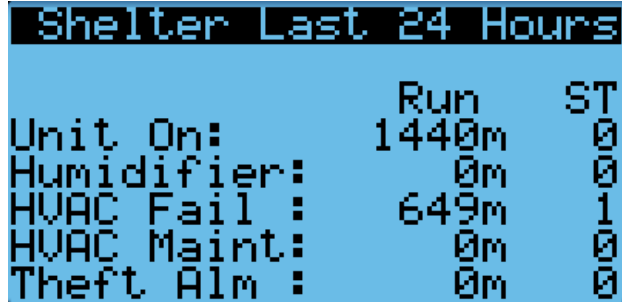

*Shelter Info*

The Shelter Info screen displays the average temperature/humidity readings of the last hour (see Figure 17).

**FIGURE 17**  
Shelter Info

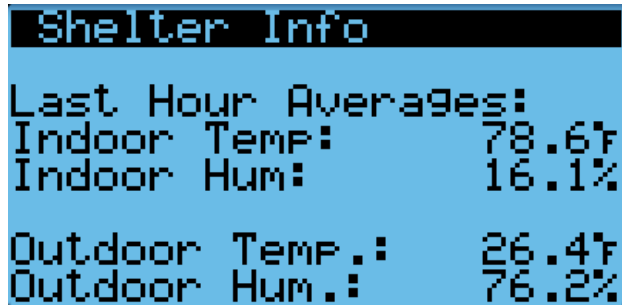

*Software Info*

The Software Info screen (Figure 18) displays all program version information for the PLC (see *Software Versioning Guide* section on page 19). This information can be used to determine whether a software update may be required. This screen also displays the PLC operating system version and processor core type.

**FIGURE 18**  
Software Info



Software Versioning Guide

LVS1000.X.Y.Z\_Core#

Software Name: The name of the software is the base part number used to identify which product the software is used in.

**TABLE 3**  
Software Versioning Guide

Product	Software Name
LV1000	LVS1000
FUSION-TEC (HR)	FTS1000

- X The letter X represents a major change to the software effecting product compatibility or function of the equipment.
- Y The letter Y represents a minor change to the software that either adds, removes, or alters a feature of the equipment without effecting compatibility with other products.
- Z The letter Z represents a change to the software that fixes existing features or user interface.

Core: Identifies the processor core type of the PLC.

Unit Information

The LV1000 has the ability to provide individual wall unit information which it displays in individual unit information screens. The purpose of these screens is to eliminate the need to remove the panel from a wall unit in order to plug in the TEC-EYE™. Each unit information menu item displays the following information: unit main status screen mirror, unit A/C circuit information, unit model/serial number, unit last 24 hour run times and component lifetimes.

Unit Main Status Screen Mirror

The Unit Main Status screen (Figure 19) mirrors the main status screen of the wall unit. The main status screen also shows the return air temperature (RAT), mixed air temperature (MAT), outdoor air temperature (OAT), outdoor air humidity (OAH) and outdoor dew point (ODP) conditions. Blower speed, condenser fan speed, damper position and unit status are also displayed. In addition to what is displayed on the wall unit's main status screen, this screen also displays the actual wall unit output staging. Refer to the latest version of unit service manual 2100-694 for a list of wall-mount unit status messages.

**FIGURE 19**  
Unit Main Status Screen Mirror

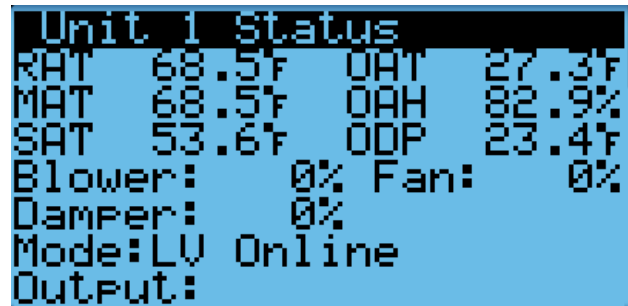

Unit A/C Circuit Information

The A/C Circuit Information screen lists all available A/C sensor measurements and calculations on the unit specified (see Figure 20). The information and measurements provided are liquid line temperature, liquid line pressure, condensing saturated temperature, suction line temperature, suction line pressures, suction saturated temperature, super heat, sub-cooling and electronic expansion valve position.

**FIGURE 20**  
Unit A/C Circuit Information

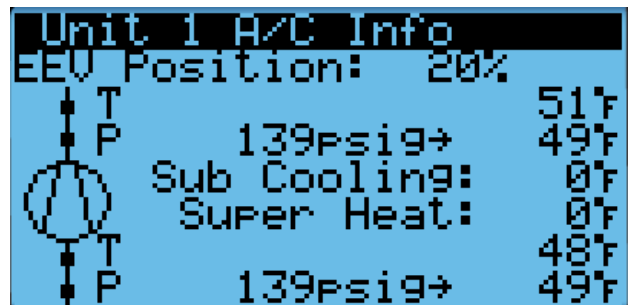

Unit Model/Serial Number/Software Version

The Unit Model/Serial Number and Software version screen allows the user to verify the model number, serial number and software version from the LV1000 display (see Figure 21).

**FIGURE 21**  
Unit Model/Serial Number and Software Version

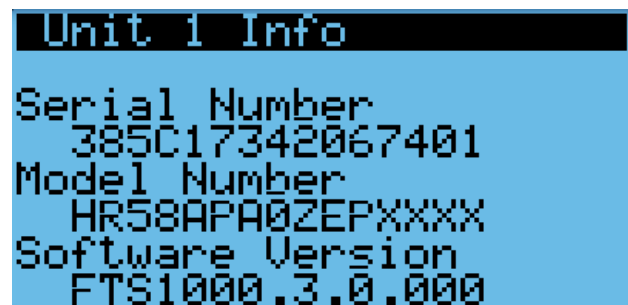

### Unit Last 24 Hours Operation

The Unit Last 24 Hours Operation information tracks the runtimes (**Run**) and start calls (**ST**) of different unit operations in the last 24 hour period (see Figure 22).

**FIGURE 22**  
Unit Last 24 Hours Operation

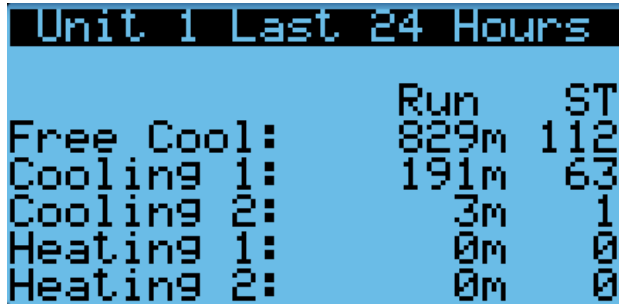

	Run	ST
Free Cool:	829m	112
Cooling 1:	191m	63
Cooling 2:	3m	1
Heating 1:	0m	0
Heating 2:	0m	0

### Alarm Log

The alarm log displays the record number, time of alarm event, date of alarm event, description of alarm event and whether the entry is the beginning or end of event. The data log will have as many screens as events occurred, up to 64 entries.

### Changing to Celsius

1. Press MENU key to go to the Main Menu screen.
2. Use UP or DOWN keys and ENTER key to enter USER password 2000.
3. Press UP or DOWN keys to scroll to **Sys Config**; press ENTER key.
4. Press UP or DOWN keys to scroll to **Unit Setup A1**.
5. Press ENTER key to scroll to **UOM**.
6. Press UP and DOWN keys to change value to **SI**.

### Calibrating Sensors

1. Press MENU key to go to the Main Menu screen.
2. Use UP or DOWN keys and ENTER key to enter TECHNICIAN password 1313.
3. Press UP or DOWN keys to scroll to **I/O Config**; press ENTER key.
4. Press UP or DOWN keys to scroll to sensor to be adjusted.
5. Press ENTER key to scroll to **Offset**.
6. Press UP or DOWN keys to add or subtract to the sensor offset value.
7. Press ENTER key to save.

### Reset to Factory Defaults

To reset the LV controller to factory default settings:

1. Press MENU key to go to the Main Menu screen.
2. Use UP or DOWN keys and ENTER key to enter ENGINEER password 9254.

3. Press UP or DOWN keys to scroll to **Settings**; press ENTER key.
4. Press UP or DOWN keys to scroll to **Initialization**; press ENTER key.
5. Press UP or DOWN keys to scroll to the **Default Installation** screen; press ENTER key.
6. Press ENTER key to scroll to **Reset to Factory Defaults** (see Figure 23).
7. Press UP or DOWN key to value to **YES**; press ENTER key.
8. System will restart with default values.

**FIGURE 23**  
Restoring Factory Default Settings

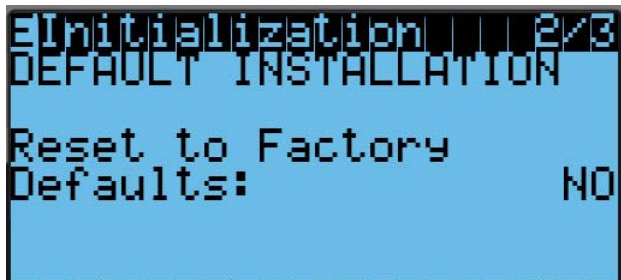

### Clear Alarm Logs

To clear the LV controller alarm logs:

1. Press MENU key to go to the Main Menu screen.
2. Use UP or DOWN keys and ENTER key to enter USER password 2000.
3. Press UP or DOWN keys to scroll to **Settings**; press ENTER key.
4. Press UP or DOWN keys to scroll to **Initialization**; press ENTER key.
5. Press ENTER key to scroll to **Clear Alarm Logs?** (see Figure 24).
6. Press UP or DOWN key to value to **YES**; press ENTER key.
7. Press ESCAPE key several times to return to Main Menu screen.

**FIGURE 24**  
Clearing LV1000 Alarm Logs

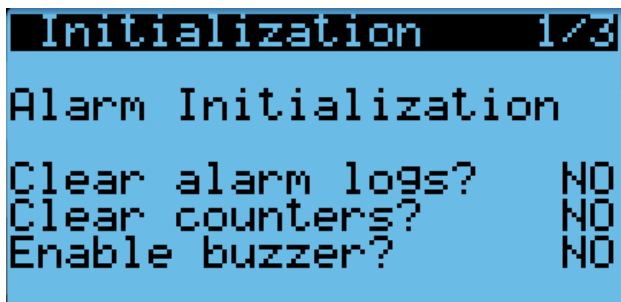



## IP Configuration

To set an LV IPv4 address:

1. Press MENU key to go to the Main Menu screen.
2. Use UP or DOWN keys and ENTER key to enter TECHNICIAN password 1313.
3. Press UP or DOWN keys to scroll to **Settings**; press ENTER key.
4. Press UP or DOWN keys to scroll to **Network Config**; press ENTER key.
5. Press UP or DOWN keys to scroll to **IPv4 Config**; press ENTER key.
6. Press ENTER key to scroll to desired value to be changed (see Figure 25).
7. Press UP or DOWN keys to change selected value.
8. Press ENTER key to save and scroll to next value.
9. When finished, press ENTER key until cursor is on the **Update Config** value; change **No** to **Yes** using the UP or DOWN key, then press ENTER key to update network configuration.

**NOTE:** Enabling/disabling IPv6 or changing from Static IP to hardware-based SLAAC IP will automatically reboot the PLC when **Update Config** value is changed.

**FIGURE 25**  
IPv4 Configuration

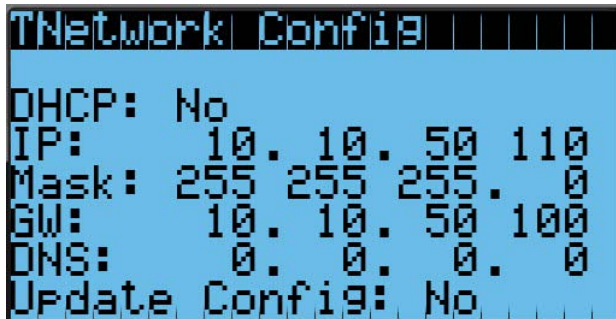

## Modbus TCP Configuration

LV1000 version 1.1.0 and higher include Modbus RTU over TCP included on the Ethernet connection. This is a Modbus Slave device and requires a Modbus Master device to properly communicate. Modbus Register list can be found on page 39 of this manual.

To make changes to the Modbus setup:

1. Press MENU key to go to the Main Menu screen.
2. Use UP or DOWN keys and ENTER key to enter TECHNICIAN password 1313.
3. Press UP or DOWN keys to scroll to **Settings**; press ENTER key.
4. Press UP or DOWN keys to scroll to **ModbusTCP Config**; press ENTER key.

5. Press ENTER key to scroll to **Address** (see Figure 26).
6. Press UP or DOWN keys change the Modbus address.
7. Press ENTER key to scroll to **Port**.
8. Press UP or DOWN keys change the Port number if needed. (Default is port 502.)
9. Press ENTER key to scroll to **UOM**.
10. Press UP or DOWN keys change the Unit of Measure for Modbus values (see Table 4).

**FIGURE 26**  
Modbus TCP Setup



**TABLE 4**  
Modbus Unit of Measure (UOM) Values

UOM Type	Temperature UOM	Pressure UOM
SI	°C	KPA
USA (Default)	°F	PSI
UK	°C	BAR
CAN	°C	PSI
LON	°C	KPA

# ALARMS

**NOTE:** Screenshots shown in this manual reflect default settings (when applicable).

## Alarm Adjustment

### Acknowledging/Clearing Alarms

When there are active alarm conditions on the system, a red LED indicator will backlight the ALARM function key. As an option, an alarm condition may also be enunciated by an audible alarm signal. Active alarms on the system can be viewed by pressing the ALARM key. This calls up the alarm display screen(s) that provide a text message detailing the active alarm condition(s).

After an alarm condition is corrected, the alarm can be cleared by pressing the ALARM key for 3 seconds if that specific alarm is not self-clearing. To reset all alarms on the system, from the alarm display screen, press UP or DOWN key until the screen appears that states **Press ALARM for 3s to reset all alarms** and press the ALARM key for 3 seconds (see Figure 27). If alarms do not clear, the alarm condition is still present. If the alarms clear, the screen should display **NO ALARMS**.

**FIGURE 27**  
Clearing All Alarms



### Sensor Failure Alarms

The controller is capable of determining if a sensor has failed. If the temperature or humidity measurement is outside the ranges shown in Table 5, the controller will consider the sensor as failed.

The sensor failure alarms are self clearing.

**TABLE 5**  
Temperature and Humidity Sensors

Sensor	Range
Indoor Temperature 1	-41°F to 303°F
Indoor Temperature 2	-41°F to 303°F
Indoor Temperature 3	-41°F to 303°F
Indoor Humidity 1	10-90%
Indoor Humidity 2	10-90%
Indoor Humidity 3	10-90%

### No Temperature Sensor Alarm

If the LV1000 indoor temperature sensors fail, a no temperature sensor alarm will be active and displayed in the alarms page. However, the controller will continue to operate as long as the lead unit has a functional return air temperature sensor. When the no temperature sensor alarm occurs, the LV1000 will enable continuous blower on the lead unit and use the return air temperature sensor to control space temperature.

### Temperature Alarms (Low Temp, High Temp Warn, High Temp Alarm)

#### Low Temperature Alarm

The LV will indicate an indoor low temperature alarm when any of the connected sensors that are enabled read a value below the low temperature limit of 40°F (factory default). By default, this alarm uses the average of sensors if more than one space sensor is used.

The low temperature alarm is self clearing.

To adjust the low temperature alarm setpoint:

1. Press MENU key to go to the Main Menu screen.
2. Use UP or DOWN keys and ENTER key to enter USER password 2000.
3. Press UP or DOWN keys to scroll to **Sys Config**; press ENTER key.
4. Press UP or DOWN keys to scroll to **Alarm Setpoints A8**.
5. Press ENTER key to scroll to **Low Temp** (see Figure 28).
6. Press UP or DOWN keys to adjust setpoint.

**FIGURE 28**  
Adjusting Temperature Alarm Setpoints

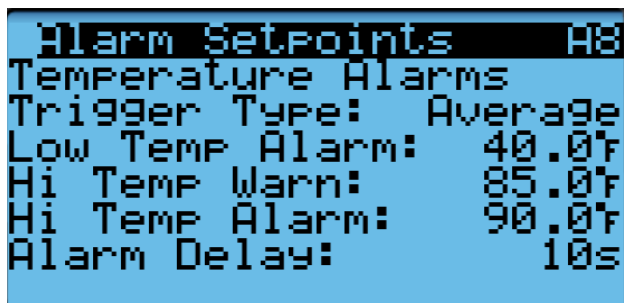

#### High Temperature Warning

The LV will indicate a high temperature warning alarm when any of the connected sensors that are enabled read a value above the high temperature limit of 85°F (factory default). By default, this alarm uses the average of sensors if more than one space sensor is enabled.

The high temperature warning alarm is self clearing.

To adjust the high temperature warning setpoint:

1. Press MENU key to go to the Main Menu screen.
2. Use UP or DOWN keys and ENTER key to enter USER password 2000.
3. Press UP or DOWN keys to scroll to **Sys Config**; press ENTER key.
4. Press UP or DOWN keys to scroll to **Alarm Setpoints A7**.
5. Press ENTER key to scroll to **High Temp Warn** (see Figure 28).
6. Press UP or DOWN keys to adjust setpoint.

#### **High Temperature Alarm**

The LV will indicate a high temperature alarm when any of the connected sensors that are enabled read a value above the high temperature limit of 90°F (factory default). By default, this alarm uses the average of sensors if more than one space sensor is enabled. In addition to the alarm being generated, this event will put the system into Emergency Cool mode. See **Emergency Cool** on page 29 for more information.

To adjust the high temperature alarm setpoint:

1. Press MENU key to go to the Main Menu screen.
2. Use UP or DOWN keys and ENTER key to enter USER password 2000.
3. Press UP or DOWN keys to scroll to **Sys Config**; press ENTER key.
4. Press UP or DOWN keys to scroll to **Alarm Setpoints A7**.
5. Press ENTER key to scroll to **High Temp Alarm** (see Figure 28).
6. Press UP or DOWN keys to adjust setpoint.

The trigger type for the low temperature, high temperature warning and high temperature alarms can be changed to reference either the displayed average or the lowest value (for low temperature alarm) and the highest value (for high temperature alarms). This only applies to multiple sensor installations. If only one sensor is used, this does not affect operation.

The default setting is **Average**.

To adjust the temperature alarms trigger type:

1. Press MENU key to go to the Main Menu screen.
2. Use UP or DOWN keys and ENTER key to enter USER password 2000.
3. Press UP or DOWN keys to scroll to **Sys Config**; press ENTER key.
4. Press UP or DOWN keys to scroll to **Alarm Setpoints A7**.
5. Press ENTER key to scroll to **Trigger Type** (see Figure 28).

6. Press UP or DOWN keys to change from **Average** to **Hi/Low**.

A delay of 10 seconds (factory default) is applied to each alarm. This can be adjusted by:

1. Press MENU key to go to the Main Menu screen.
2. Use UP or DOWN keys and ENTER key to enter USER password 2000.
3. Press UP or DOWN keys to scroll to **Sys Config**; press ENTER key.
4. Press UP or DOWN keys to scroll to **Alarm Setpoints A7**.
5. Press ENTER key to scroll to **Alarm Delay** (see Figure 28).
6. Press UP or DOWN keys to adjust the delay.

#### **Humidity Alarms (Low Hum, High Hum)**

##### **Low Humidity Alarm**

The LV will indicate an indoor low humidity alarm when any of the connected sensors that are enabled read a value below the low humidity limit of 10% RH (factory default). By default, this alarm uses the average of sensors if more than one space sensor is enabled.

The low humidity alarm is self clearing.

To adjust the low humidity alarm setpoint:

1. Press MENU key to go to the Main Menu screen.
2. Use UP or DOWN keys and ENTER key to enter USER password 2000.
3. Press UP or DOWN keys to scroll to **Sys Config**; press ENTER key.
4. Press UP or DOWN keys to scroll to **Alarm Setpoints A8**.
5. Press ENTER key to scroll to **Low Hum** (see Figure 29).
6. Press UP or DOWN keys to adjust setpoint.

**FIGURE 29**  
**Adjusting Humidity Alarm Setpoints**

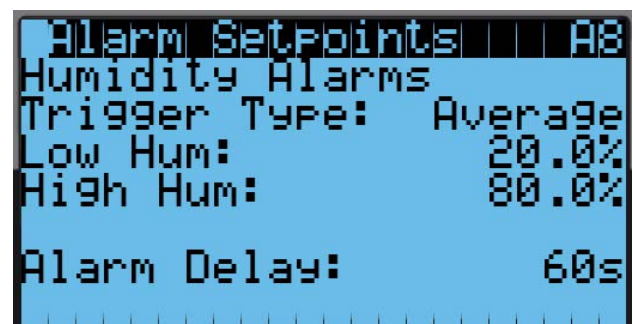

## High Humidity Alarm

The LV will indicate a high humidity alarm when any of the connected sensors that are enabled read a value above the high humidity limit of 80% RH (factory default). By default, this alarm uses the average of sensors if more than one space sensor is enabled.

The high humidity alarm is self clearing.

To adjust the high humidity alarm setpoint:

1. Press MENU key to go to the Main Menu screen.
2. Use UP or DOWN keys and ENTER key to enter USER password 2000.
3. Press UP or DOWN keys to scroll to **Sys Config**; press ENTER key.
4. Press UP or DOWN keys to scroll to **Alarm Setpoints A8**.
5. Press ENTER key to scroll to **High Hum** (see Figure 29).
6. Press UP or DOWN keys to adjust setpoint.

The trigger type for the low humidity and high humidity alarms can be changed to reference either the displayed average or the lowest value (for low humidity alarm) and the highest value (for high humidity alarm). This only applies to multiple sensor installations. If only one sensor is used, this does not affect operation.

The default setting is **Average**.

To adjust the temperature alarms trigger type:

1. Press MENU key to go to the Main Menu screen.
2. Use UP or DOWN keys and ENTER key to enter USER password 2000.
3. Press UP or DOWN keys to scroll to **Sys Config**; press ENTER key.
4. Press UP or DOWN keys to scroll to **Alarm Setpoints A8**.
5. Press ENTER key to scroll to **Trigger Type** (see Figure 29).
6. Press UP or DOWN keys to change from **Average** to **Hi/Low**.

A delay is available to be applied to each humidity alarm (default is 60 seconds). This can be adjusted by:

1. Press MENU key to go to the Main Menu screen.
2. Use UP or DOWN keys and ENTER key to enter USER password 2000.
3. Press UP or DOWN keys to scroll to **Sys Config**; press ENTER key.
4. Press UP or DOWN keys to scroll to **Alarm Setpoints A8**.
5. Press ENTER key to scroll to **Alarm Delay** (see Figure 29).
6. Press UP or DOWN keys to adjust the delay.

## Smoke Alarm

The LV will indicate a smoke alarm when the smoke detector input is activated in the shelter. This input is enabled by default. To utilize this input, connect the detector alarm relay to the smoke detector input and smoke detector common. See smoke alarm installation instructions for specific wiring information.

**NOTE:** The variable provided in the *Direction (Dir)* column of the *Digital In Config C1* screen (as shown in Figure 30) displays either **NO** (Normally Open) or **NC** (Normally Closed). This column lists the type of signaling contact connected to the LV1000. If connected to an **NO** contact on the smoke detector, the input circuit will be closed if there is a smoke event. Therefore, in this case the LV1000 must be set to look for **NO**.

To change the smoke inputs:

1. Press MENU key to go to the Main Menu screen.
2. Use UP or DOWN keys and ENTER key to enter TECHNICIAN password 1313.
3. Press UP or DOWN keys to scroll to **IO Config**; press ENTER key.
4. Press UP or DOWN keys to scroll to **Digital In Config C1**.
5. Press ENTER key to scroll to the variable in the table that intersects **Smoke** and **Dir** (see Figure 30).
6. Press UP or DOWN key to change direction.
7. Press ENTER key to save the value and move cursor to variable in the table that intersects **Smoke** and **En**.
8. Press UP or DOWN keys to change the value from **ON** to **OFF**.

FIGURE 30  
Changing Smoke Input Values

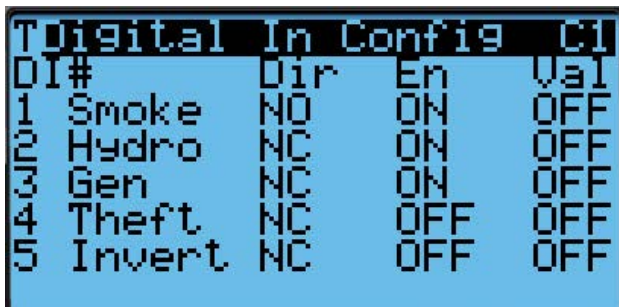

DI#	Dir	En	Val	
1	Smoke	NO	ON	OFF
2	Hydro	NC	ON	OFF
3	Gen	NC	ON	OFF
4	Theft	NC	OFF	OFF
5	Invert	NC	OFF	OFF

The response of the smoke alarm is configurable. Screen B5 has two configuration options for the smoke alarm. The first configuration (**Reset**) is for **Auto** or **User** reset. Default setting is **User** which means when the input is active an alarm is triggered and the alarm and associated functionality will not change until a user



resets the alarm. The option for **Auto** reset will reset the functionality of the alarm automatically when the input changes state.

The second setting (**Shutdown**) is for the type of function that will occur when the smoke alarm is active. The options are **System** and **Economizer**. **System** is default and will disable the entire system while the alarm is active. All cooling, heating, blower and damper operation will cease. The second option **Economizer** will shut down only the economizer while the alarm is active.

To change the settings for the smoke alarm configuration:

1. Press MENU key to go to the Main Menu screen.
2. Use UP or DOWN keys and ENTER key to enter TECHNICIAN password 1313.
3. Press UP or DOWN keys to scroll to **Adv System Config**; press ENTER key.
4. Press UP or DOWN keys to scroll to **Fire/Smoke Config B5**.
5. Press ENTER key to scroll to **Reset** (see Figure 31).
6. Press UP or DOWN key to change **Auto** to **User**.
7. Press ENTER key to save the value and move cursor to **Shutdown**.
8. Press UP or DOWN keys and ENTER key to change **System** to **Econ**.
9. Press ENTER key to save.

**FIGURE 31**  
Changing Smoke Alarm Configuration

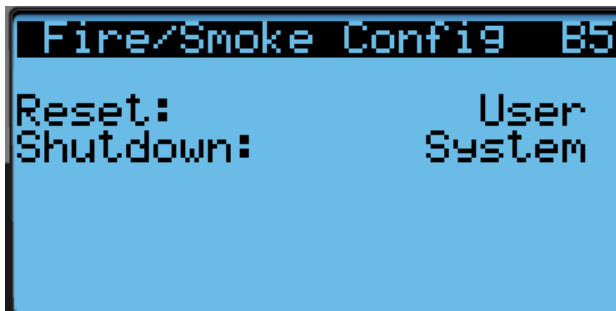

### Hydrogen Alarm

The LV will indicate a hydrogen alarm when the hydrogen detector indicates high levels of hydrogen inside the shelter. This input is enabled by default but comes with a factory-installed jumper. To utilize this input, remove the jumper and connect the sensor in place of the jumper. In addition to the alarm being generated, this event will put the system into emergency vent mode. See **Emergency Vent** on page 29 for more information. This alarm will automatically clear when the hydrogen detector no longer indicates hydrogen is present.

**NOTE:** The variable provided in the Direction (Dir) column of the Digital In Config C1 screen (as shown in Figure 30) displays either NO (Normally Open) or NC (Normally Closed). This column lists the type of signaling contact connected the LV1000. If connected to an NC contact on the hydrogen detector, the input circuit will be open if there is a hydrogen event. Therefore, in this case the LV1000 must be set to look for NC.

To change the hydrogen inputs:

1. Press MENU key to go to the Main Menu screen.
2. Use UP or DOWN keys and ENTER key to enter TECHNICIAN password 1313.
3. Press UP or DOWN keys to scroll to **IO Config**; press ENTER key.
4. Press UP or DOWN keys to scroll to **Digital In Config C1**.
5. Press ENTER key to scroll to the variable in the table that intersects **Hydro** and **Dir** (see Figure 30).
6. Press UP or DOWN key to change direction.
7. Press ENTER key to save the value and move cursor to variable in the table that intersects **Hydro** and **En**.
8. Press UP or DOWN keys to change the value from **ON** to **OFF**.

### Generator Alarm

The LV will indicate a generator run alarm when the generator run input indicates that the generator is running. This input is enabled by default but comes with a factory-installed jumper. To utilize this input, remove the jumper and connect the generator in place of the jumper.

**NOTE:** The variable provided in the Direction (Dir) column of the Digital In Config C1 screen (as shown in Figure 30) displays either NO (Normally Open) or NC (Normally Closed). This column lists the type of signaling contact connected the LV1000. If connected to an NC contact on the generator, the input circuit will be open when the generator is running. Therefore, in this case the LV1000 must be set to look for NC.

To change the generator inputs:

1. Press MENU key to go to the Main Menu screen.
2. Use UP or DOWN keys and ENTER key to enter TECHNICIAN password 1313.
3. Press UP or DOWN keys to scroll to **IO Config**; press ENTER key.
4. Press UP or DOWN keys to scroll to **Digital In Config C1**.
5. Press ENTER key to scroll to the variable in the table that intersects **Gen** and **Dir** (see Figure 30).

6. Press UP or DOWN key to change direction.
7. Press ENTER key to save the value and move cursor to variable in the table that intersects **Gen** and **En**.
8. Press UP or DOWN keys to change the value from **ON** to **OFF**.

While the generator is running, the system will only allow selected units to run. This selection is customizable by the end user. This limitation is in place to match the unit power requirements to the shelter generator capacity.

The default for this setting is 1 unit is permitted to run if 1, 2, or 3 is selected for the number of units installed on the shelter. If the shelter is configured for 4 units, the default will be 2 units. If a different strategy is required, the end user can select which units by address are allowed to run when the generator run input is active.

To change which units run when the generator run input is active:

1. Press MENU key to go to the Main Menu screen.
2. Use UP or DOWN keys and ENTER key to enter TECHNICIAN password 1313.
3. Press UP or DOWN keys to scroll to **Adv System Config**; press ENTER key.
4. Press UP or DOWN keys to scroll to **Unit Inhibit B3**.
5. Press ENTER key to scroll to **Unit 1** (see Figure 32).
6. Press UP or DOWN key to change **Enabled on Gen** to **Disabled on Gen**.
7. Press ENTER key to save the value and move cursor to **Unit 2**.
8. Press UP or DOWN keys and ENTER key to change units to **Disabled on Gen** as needed.

**FIGURE 32**  
Adjusting Units Running When Generator is Active

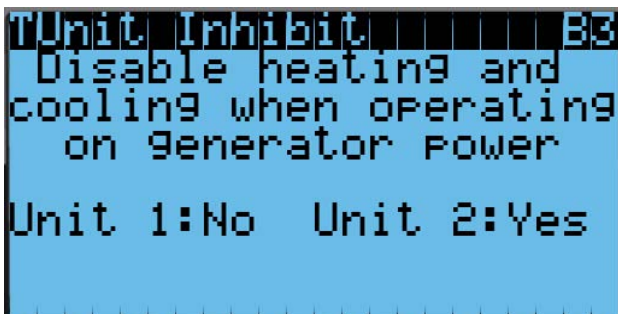

The system will also disable economizer operation of all wall-mount units when the generator is running. This setting can be changed per wall-mount unit by the end user to allow the economizer to operate if the exhaust of the generator is far enough away from the wall-mount unit's fresh air intake.

To change which units can use the economizer when the generator run input is active:

1. Press MENU key to go to the Main Menu screen.
2. Use UP or DOWN keys and ENTER key to enter TECHNICIAN password 1313.
3. Press UP or DOWN keys to scroll to **Adv System Config**; press ENTER key.
4. Press UP or DOWN keys to scroll to **Econ Inhibit B2**.
5. Press ENTER key to scroll to **Unit 1** (see Figure 33).
6. Press UP or DOWN key to change **Enabled on Gen** to **Disabled on Gen**.
7. Press ENTER key to save the value and move cursor to **Unit 2**.
8. Press UP or DOWN keys and ENTER key to change units to **Disabled on Gen** as needed.

This alarm will clear and operation will return to normal when the generator run input no longer indicates the generator is running.

**FIGURE 33**  
Adjusting Economizers Running  
When Generator is Active

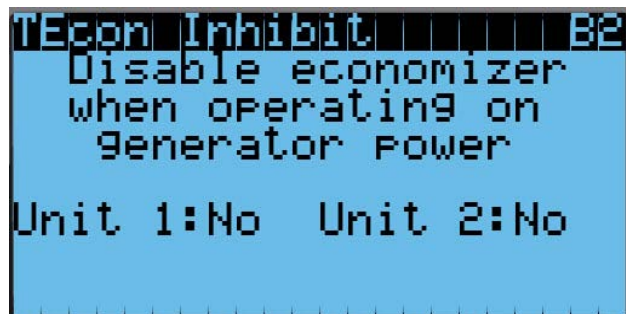

#### Utility Power Loss Alarm

The LV will indicate a utility power loss alarm if equipped with inverter-ready wall-mount units. When utility power is not present, the wall-mount unit controller will detect a power loss and communicate the event to the LV. The LV will then indicate a utility power loss alarm. When the power loss alarm is no longer present, the alarm will automatically clear.

#### Inverter Failure Alarm

The LV has the ability to monitor the VIC Series inverter (sold separately) for a failure. Once wired from the inverter



fault relay in the VIC inverter to terminals 16 and 17 in the LV1000-300, the LV will alarm on inverter failure.

**NOTE:** The variable provided in the Direction (Dir) column of the Digital In Config C1 screen (as shown in Figure 30) displays either NO (Normally Open) or NC (Normally Closed). This column lists the type of signaling contact connected to the LV1000. If connected to an NC contact on the inverter, the input circuit will be open when the inverter reports a fault. Therefore, in this case the LV1000 must be set to look for NC.

### HVAC Fail Alarm

The LV monitors all connected wall-mount unit alarms. If any of the units communicate specific alarms, the LV will actuate an HVAC fail alarm relay output. The following wall-mount unit events have the possibility of actuating an HVAC failure: High pressure (always), low pressure (always), blower failure (always), high temperature warning (user selectable), high temperature alarm (user selectable) and low temperature alarm (user selectable). Each event will be displayed individually on the LV. However, any of these alarms (when enabled) will actuate the alarm relay for HVAC failure. This output is connected to the NOC for remote notification. When all of these events are no longer present, the alarm relay output will close, signaling there are no HVAC failure alarms.

The LV will actuate a relay output when this alarm occurs. The output is set up to open when an alarm occurs by default. The direction of this alarm output can be changed if required.

To change the direction of the HVAC fail alarm output:

1. Press MENU key to go to the Main Menu screen.
2. Use UP or DOWN keys and ENTER key to enter TECHNICIAN password 1313.
3. Press UP or DOWN keys to scroll to **IO Config**; press ENTER key.
4. Press UP or DOWN keys to scroll to **Digital Out Config C2**.
5. Press ENTER key to scroll to the variable in the table that intersects **HVACfail** and **Dir** (see Figure 34).
6. Press UP or DOWN key to change direction.

**FIGURE 34**  
Changing HVAC Fail Alarm Output Direction

DO#	Dir	Val
1 Hum	NO	OFF
2 HVACfail	NC	ON
3 HVACmaint	NC	ON
4 AntiTheft	NC	ON

To change the alarms that actuate an HVAC fail alarm:

1. Press MENU key to go to the Main Menu screen.
2. Use UP or DOWN keys and ENTER key to enter TECHNICIAN password 1313.
3. Press UP or DOWN keys to scroll to **IO Config**; press ENTER key.
4. Press UP or DOWN keys to scroll to **HVAC Fail Config C3**.
5. Press ENTER key to scroll to the failure type enable (see Figure 35).
6. Press UP or DOWN key to change value.
7. Press ENTER key to save.

**FIGURE 35**  
Changing HVAC Fail Alarms

Failure Type	Enable
Hi Temp Warn	Disabled
Hi Temp Alarm	Disabled
Low Temp	Disabled

### HVAC Maintenance Alarm

The LV monitors all connected wall-mount unit alarms, and if any of the units communicate specific alarms, the LV will actuate an HVAC maintenance alarm relay output. The following alarms/events have the possibility of actuating an HVAC failure: Dirty filter alarm (always), dirty condenser coil alarm (always), lead +1/lag unit running (user selectable), economizer fail (user selectable), communications failure (user selectable). For all cases except lead +1, each of the alarms will be displayed individually on the LV. However, any of these alarms (when enabled) will actuate the alarm relay for HVAC maintenance, which is connected to the NOC for remote notification. When all of these events are no longer present, the alarm relay output will close signaling there are no HVAC maintenance alarms.

The LV will actuate a relay output when this alarm occurs. The output is set up to open when an alarm occurs by default. The direction of this alarm output can be changed if required.

To change the direction of the maintenance alarm output:

1. Press MENU key to go to the Main Menu screen.
2. Use UP or DOWN keys and ENTER key to enter TECHNICIAN password 1313.

3. Press UP or DOWN keys to scroll to **IO Config**; press ENTER key.
4. Press UP or DOWN keys to scroll to **Digital Out Config C2**.
5. Press ENTER key to scroll to the variable in the table that intersects **HVACmaint** and **Dir** (see Figure 34).
6. Press UP or DOWN key to change direction.

To change the alarms that actuate an HVAC maintenance alarm:

1. Press MENU key to go to the Main Menu screen.
2. Use UP or DOWN keys and ENTER key to enter TECHNICIAN password 1313.
3. Press UP or DOWN keys to scroll to **IO Config**; press ENTER key.
4. Press UP or DOWN keys to scroll to **HVAC Maint Config C4**.
5. Press ENTER key to scroll to the maintenance type enable (see Figure 36).
6. Press UP or DOWN key to change value.
7. Press ENTER key to save.

**FIGURE 36**  
Changing HVAC Maintenance Alarms

Failure Type	Enable
Lead +1	Disabled
Econ. Fail	Disabled
Comm. Fail	Disabled

### Anti-Theft Alarm

The LV will indicate a theft alarm when the Bard Guard anti-theft controller (sold separately) indicates an alarm to the anti-theft input on the LV. This alarm will open an alarm relay output to the NOC for remote notification. When the input no longer indicates a theft, the alarm will automatically clear and the alarm relay will return to its normal state.

**NOTE:** The variable provided in the Direction (Dir) column of the Digital In Config C1 screen (as shown in Figure 30) displays either NO (Normally Open) or NC (Normally Closed). This column lists the type of signaling contact connected the LV1000. If connected to an NC contact on the Bard Guard Anti-Theft Alarm, the input circuit will be open when the Bard Guard reports a theft event. Therefore, in this case the LV1000 must be set to look for NC.

To change the anti-theft alarm inputs:

1. Press MENU key to go to the Main Menu screen.
2. Use UP or DOWN keys and ENTER key to enter TECHNICIAN password 1313.
3. Press UP or DOWN keys to scroll to **IO Config**; press ENTER key.
4. Press UP or DOWN keys to scroll to **Digital In Config C1**.
5. Press ENTER key to scroll to the variable in the table that intersects **Theft** and **Dir** (see Figure 30).
6. Press UP or DOWN key to change direction.
7. Press ENTER key to save the value and move cursor to variable in the table that intersects **Theft** and **En**.
8. Press UP or DOWN key to change the value from **OFF** to **ON**.

The LV is will actuate a relay output when this alarm occurs. The output is set up to open when an alarm occurs by default. The direction of this alarm output can be changed if required.

To change the direction of the anti-theft output:

1. Press MENU key to go to the Main Menu screen.
2. Use UP or DOWN keys and ENTER key to enter TECHNICIAN password 1313.
3. Press UP or DOWN keys to scroll to **IO Config**; press ENTER key.
4. Press UP or DOWN keys to scroll to **Digital Out Config C2**.
5. Press ENTER key to scroll to the variable in the table that intersects **AntiTheft** and **Dir** (see Figure 34).
6. Press UP or DOWN key to change direction.

**NOTE:** Screenshots shown in this manual reflect default settings (when applicable).

## Temperature Control

### Control Value Averaging

The system requires one temperature and humidity sensor (included with LV) to operate. It allows a **total** of three temperature sensors and three humidity sensors to be connected to the LV for better representation of what is happening in the shelter. When more than one sensor is used, the value is averaged and then used for temperature control operations and humidity control operations.

### Comfort Mode

The LV has a feature that allows a temporary override of the temperature control settings. When “comfort mode” is activated, the system will control to 72°F. The system will stay in this mode for 60 minutes and is intended to provide a more comfortable space for a technician during a service call or scheduled maintenance.

### Emergency Vent

When the hydrogen input indicates an alarm, the system will enter emergency vent mode. The LV will communicate to each wall-mount unit that emergency vent mode is active. The wall-mount units will then override the damper position to 100% open and, after a short delay to allow the damper to open, turn the blower on. Emergency vent mode will stay active until the hydrogen detector is no longer in an alarm state.

### Emergency Cool

When the high temperature alarm is activated, the system will enter emergency cool mode. The LV will communicate to each wall-mount unit that emergency cool mode is active. At that point, the units will override any restrictions to the economizer disable and operate the economizers normally, as long as the outdoor temperature is cooler than the indoor temperature. Emergency cool mode will stay active until the high temperature warning is no longer in an alarm state.

### Cooling

When the wall-mount units are connected to the LV, the economizer and compressor are commanded off and on by the LV. This allows the supervisory controller to consider the most effective and efficient order to bring cooling functions on using all of the available equipment installed on the shelter. At the same time, the LV will be able to match the load requirements of the shelter.

To adjust the cooling setpoint:

1. Press MENU key to go to the Main Menu screen.
2. Press UP or DOWN keys and ENTER key to enter USER password 2000.

3. Press UP or DOWN keys to scroll to **Sys Config**; press ENTER key.
4. Press UP or DOWN keys to scroll to **Unit Setup A1**; press ENTER key.
5. Press ENTER key to scroll to **Cooling** (see Figure 37).
6. Press UP or DOWN keys to adjust value.
7. Press ENTER key to save.
8. Press the ESCAPE key several times to return to Main Menu screen.

**FIGURE 37**  
Adjusting Setpoints

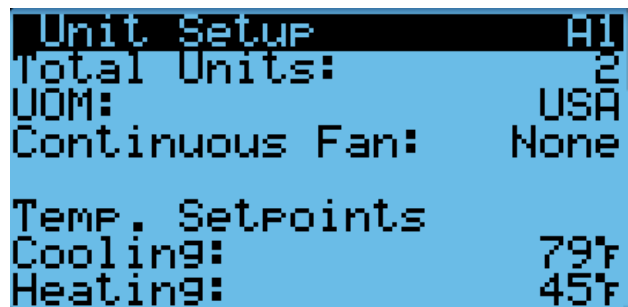

The LV monitors the space temperature and compares the value to the space cooling setpoint. The system will compare how far above or below the space temperature is when compared to the cooling setpoint. The LV will also consider how long the shelter temperature has been above or below the setpoint. Using these two considerations, the controller will generate a cooling demand. The cooling demand is a value between 0 and 100%. 0% represents no cooling demand and 100% representing full cooling demand.

The system will consider all of the available cooling stages and distribute the number of stages across the cooling demand range. As the demand rises, the system will stage on equipment. As the demand lowers, the system will stage off equipment.

The system will stage the equipment on in the order shown in Table 6 on page 30.

### Unit Rotation

The system is also capable of rotating the order in which the units are brought on. This is done to distribute the equipment run time to each unit. This prevents one unit from providing all of the cooling for the shelter and shorting the lifespan of the wall-mount unit.

The system is set to switch the unit rotation order every 7 days from the factory. This timeframe is adjustable. In addition to the time-based auto rotation, the system can be manually rotated on site for troubleshooting purposes.

**TABLE 6**  
**Staging**

LIFO: Last In First Out								
	Alternating Stage Up		Non-Alternating Stage Up		Alternating Stage Down		Non-Alternating Stage Down	
Stage	1	2	1	2	1	2	1	2
Unit 1	1	5	1	2	8	4	8	7
Unit 2	2	6	3	4	7	3	6	5
Unit 3	3	7	5	6	6	2	4	3
Unit 4	4	8	7	8	5	1	2	1

FIFO: First In First Out								
	Alternating Stage Up		Non-Alternating Stage Up		Alternating Stage Down		Non-Alternating Stage Down	
Stage	1	2	1	2	1	2	1	2
Unit 1	1	5	1	2	5	1	2	1
Unit 2	2	6	3	4	6	2	4	3
Unit 3	3	7	5	6	7	3	6	5
Unit 4	4	8	7	8	8	4	8	7

Simultaneous: All Units Act As One				
	Stage Up		Stage Down	
Stage	1	2	1	2
Unit 1	1	2	2	1
Unit 2	1	2	2	1
Unit 3	1	2	2	1
Unit 4	1	2	2	1

To view the lead unit and make adjustments to the unit rotation

1. Press MENU key to go to the Main Menu screen.
2. Press UP or DOWN keys and ENTER key to enter USER password 2000.
3. Press UP or DOWN keys to scroll to **Sys Config**; press ENTER key.
4. Press UP or DOWN keys to scroll to **Unit Rotation A2**; press ENTER key.
5. Press ENTER key to scroll to **Time Based** (see Figure 38).
6. Press UP or DOWN key to change the value from **ON** to **OFF**.
7. Press ENTER key to save the value and scroll to **Num. of Days**.
8. Press UP or DOWN keys to change the value.
9. Press ENTER key to save the value and scroll to **Manual Rotate**.

10. Press UP or DOWN key to change the value from **OFF** to **ON**.
11. Press ENTER key to save.
12. Press the ESCAPE key several times to return to Main Menu screen.

**FIGURE 38**  
**Adjusting Unit Rotation Parameters**

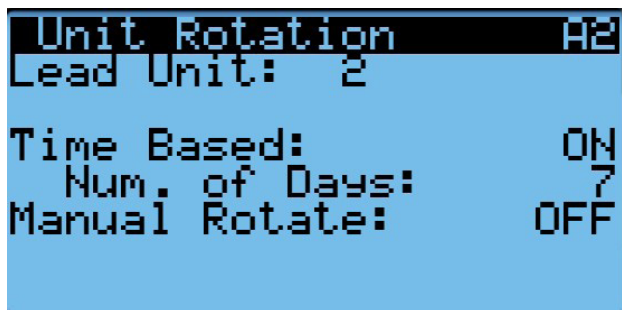

## Staging

The system has two different modes for staging unit operation: FIFO (First In First Out) or LIFO (Last In First Out). With FIFO staging, the first unit on will be the first unit to turn off as demand decreases. In LIFO staging, the first unit to turn on will be the last unit to turn off.

### Simultaneous Staging and Alternating Staging Options

The LC6000 currently will stage each unit all the way up before moving to the next unit in rotation. This feature will add the ability to engage stage 1 in every unit in the zone before moving to stage 2 and engage stage 2 in all units before engaging stage 3. It will also allow all units in a zone to stage at the same time.

### Staging Order

This setting will determine the order in which the units are turned on and off.

FIFO: The first unit staged on will be the first unit staged off

LIFO: The last unit staged on will be the first unit staged off

### Staging Type

1. Alternating: The first stage of each unit will be engaged according to the staging order. Once all available units have stage 1 engaged, the second stage of each unit will be engaged according to the staging order. Once all available units have stage 2 engaged, the third stage of each unit will be engaged according to the staging order. The 3rd stage of each unit will disengage according to the staging order. Once all available units have stage 3 disengaged, the 2nd stage of each unit will be staged down according to the staging order. Once all available units have stage 2 disengaged, the 1st stage of each unit will disengage according to the staging order.

**NOTE:** Units with more staging capability will be turned off before units with lower staging capability even if staging order indicates they should be the next off. Units with fewer stages active will be staged up before units with more stages active.

2. Non-Alternating: The first unit in the staging order will be staged up fully before moving to the next unit in the staging order. This will continue until the last unit is staged up fully or demand decreases. When the demand decreases, the first unit to turn off based on the staging order will stage down fully before moving to the next unit. This will continue until the last unit is staged down or demand begins to increase again.
3. Simultaneous: All units in the zone will be staged up together acting as one system using the maximum number of stages detected in the zone.

To make adjustments to the unit staging:

1. Press MENU key to go to the Main Menu screen.
2. Press UP or DOWN keys and ENTER key to enter USER password 2000.
3. Press UP or DOWN keys to scroll to **Sys Config**; press ENTER key.
4. Press UP or DOWN keys to scroll to **Unit Staging A7**; press ENTER key.
5. Press ENTER key to scroll to **Time Based** (see Figure 39).
6. Press UP or DOWN key to change the **Type** value.
7. Press ENTER key to save the value and scroll to **Order**.
8. Press UP or DOWN keys to change the value.
9. Press ENTER key to save.
10. Press the ESCAPE key several times to return to Main Menu screen.

**FIGURE 39**  
**Adjusting Unit Staging**

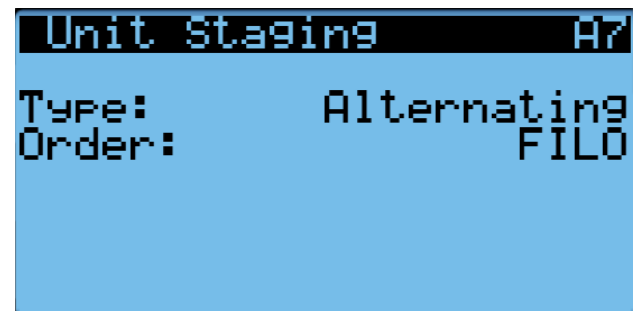

### Freecooling (Economizer) Operation

Changing the Vent Package model number value to a "B" (see wall mount unit model nomenclature in unit installation or service instructions) simulates a blank-off plate configuration and will disable economizer function for the unit, with the exception of emergency ventilation functions. When the vent package model number value is changed to "B", the economizer control type listed on screen **Economizer B1** (see Figure 40 on page 32) will change to **None** regardless of system ventilation control type.

The economizer has four types of operation. The first mode is "None" where the economizer is never utilized, except for emergency purposes. The second mode is "Dry Bulb" where the outdoor temperature is the only consideration for economizer use on a free cooling call. The third mode is "TempHum" where the outdoor temperature and humidity are considered for economizer use on a free cooling call. The fourth mode is "Enthalpy" where the outdoor temperature, humidity and calculated dew point are considered for economizer operation on a free cooling call.



To change the economizer type:

1. Press MENU key to go to the Main Menu screen.
2. Press UP or DOWN keys and ENTER key to enter TECHNICIAN password 1313.
3. Press UP or DOWN keys to scroll to **Adv System Config**; press ENTER key.
4. Press UP or DOWN keys to scroll to **Economizer Setup B1**.
5. Press ENTER key to scroll to **Econ Mode** (see Figure 40).
6. Press UP or DOWN keys to change the desired value to **None, Dry Bulb, TempHum** or **Enthalpy**.

**NOTE:** The setpoint options on this screen will change based on what mode is selected. If **None** is selected, economizer setpoints will not be displayed.

7. Press ENTER key to save the value and scroll to the next parameter.
8. The cursor should now be on the **OA Temp Set** parameter.
9. Press UP or DOWN keys to change the parameter to the desired value.
10. Press ENTER key to save the value and scroll to the next parameter.
11. The cursor should now be on **OH Humid Set** parameter.
12. Press UP or DOWN keys to change the parameter to the desired value.
13. Press ENTER key to save the value and move to the next parameter.
14. The cursor should now be on the **Dew Point Set** parameter.
15. Press UP or DOWN keys to change the parameter to the desired value.
16. Press ENTER key to save.

**FIGURE 40**  
**Economizer Setup**

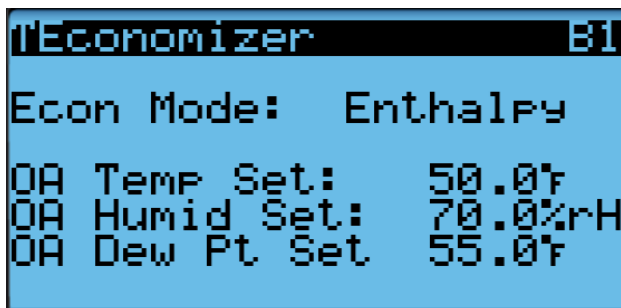

## Heating

When the wall-mount units are connected to the LV, the heat strips are commanded off and on by the LV. This allows the supervisory controller to match the required load of the shelter using all of the available equipment installed on the shelter.

To adjust the heating setpoint:

1. Press MENU key to go to the Main Menu screen.
2. Press UP or DOWN keys and ENTER key to enter USER password 2000.
3. Press UP or DOWN keys to scroll to **Sys Config**; press ENTER key.
4. Press UP or DOWN keys to scroll to **Unit Setup A1**; press ENTER key.
5. Press ENTER key to scroll to **Heating** (see Figure 37 on page 29).
6. Press UP or DOWN keys to adjust value.
7. Press ENTER key to save.
8. Press the ESCAPE key several times to return to Main Menu screen.

The LV monitors the space temperature and compares the value to the space heating setpoint. The system will compare how far above or below the space temperature is when compared to the heating setpoint. The LV will also consider how long the shelter temperature has been above or below the setpoint. Using these two considerations, the controller will generate a heating demand. The heating demand is a value between 0 and 100%. 0% represents no heating demand and 100% representing full heating demand.

The system will consider all of the available heating stages and distribute the number of stages across the heating demand range. As the demand rises, the system will stage on equipment. As the demand lowers, the system will stage off equipment.

The system will stage the equipment on in the order shown in Table 6 on page 30.

## Humidity Control

The LV will monitor the indoor humidity of the space and compare the value to the indoor humidity lower and upper setpoints.

### Humidification

When the humidity is below the lower setpoint of 20% RH and a humidifier output is configured, the shelter will begin to humidify using the relay output to control a third party humidifier.

To change the number of humidifiers, type and setpoint:

1. Press MENU key to go to the Main Menu screen.
2. Press UP or DOWN keys and ENTER key to enter USER password 2000.



3. Press UP or DOWN keys to scroll to **Sys Config**; press ENTER key.
4. Press UP or DOWN keys to scroll to **Unit Setup A3**; press ENTER key.
5. Press ENTER key to scroll to **Humidifiers** (see Figure 41).
6. Press UP or DOWN keys to adjust value.
7. Press ENTER key to scroll to **Type**.
8. Press UP or DOWN keys to adjust value.
9. Press ENTER key to scroll to **On Setpoint**.
10. Press UP or DOWN keys to adjust value.
11. Press the ESCAPE key several times to return to Main Menu screen.

**FIGURE 41**  
Adjusting Humidifiers Settings

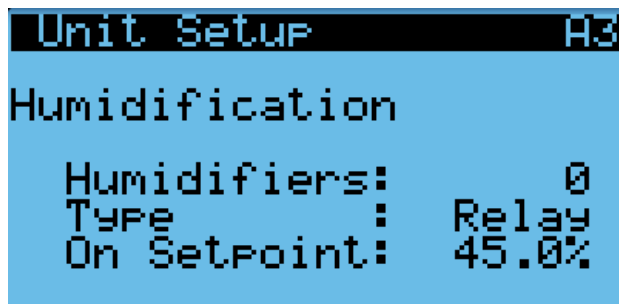

#### **Humidifier Output**

The LV has the option to control a humidifier (sold separately) through a relay output. The output will close when a humidity call from the LV is active and open when the call is no longer present. The output can be configured to operate in reverse where the contacts will open when a humidity call is present and close when the call is no longer present.

To change the direction of the humidifier output:

1. Press MENU key to go to the Main Menu screen.
2. Use UP or DOWN keys and ENTER key to enter TECHNICIAN password 1313.
3. Press UP or DOWN keys to scroll to **IO Config**; press ENTER key.
4. Press UP or DOWN keys to scroll to **Digital Out Config C2**.
5. Press ENTER key to scroll to the variable in the table that intersects **Hum** and **Dir** (see Figure 42).
6. Press UP or DOWN key to change direction.

**FIGURE 42**  
Changing Humidifier Output Direction

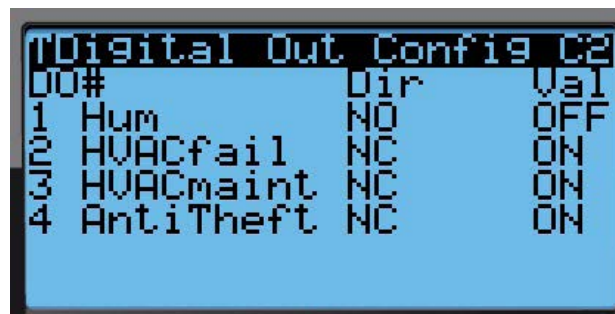

#### **Dehumidification**

The system will take several measures to limit the indoor humidity levels when they reach specified setpoints. These measures include passive dehumidification and active dehumidification.

#### **Passive Dehumidification**

Passive dehumidification means that the system will modify normal operation measures to reduce and extract humidity from the space, without generating any extra demand on the system. These measures include limiting the economizer from allowing outdoor humidity into the indoor space, disabling the high sensible blower setting to allow for more latent heat removal and enabling a slower blower speed than nominal, when applicable, to increase the latent heat removal capability. Passive dehumidification turns on when the indoor humidity rises above the passive dehum setpoint and shuts off after the indoor humidity level falls below the dehum off setpoint.

#### **Active Dehumidification**

Active dehumidification means that the system will take extra measures to extract humidity from the indoor space. Active dehumidification will work with passive dehumidification but will use one unit that is capable to heat and cool the space in a cycle with reduced blower speeds to extract the most moisture from the indoor room. Active dehumidification turns on when the indoor humidity rises above the active dehum setpoint and shuts off after the indoor humidity level falls below the dehum off setpoint.

To adjust the dehumidification setpoints:

1. Press MENU key to go to the Main Menu screen.
2. Press UP or DOWN keys and ENTER key to enter USER password 2000.
3. Press UP or DOWN keys to scroll to **Sys Config**; press ENTER key.
4. Press UP or DOWN keys to scroll to **Unit Setup A4**; press ENTER key.
5. Press ENTER key to scroll to **Dehum Off** (see Figure 43 on page 34).

6. Press UP or DOWN keys to adjust value.
7. Press ENTER key to scroll to **Passive On**.
8. Press UP or DOWN keys to adjust value.
9. Press ENTER key to scroll to **Active On**.
10. Press UP or DOWN keys to adjust value.
11. Press ENTER key to save.
12. Press the ESCAPE key several times to return to Main Menu screen.

**FIGURE 43**  
Adjusting Dehumidification Setpoints

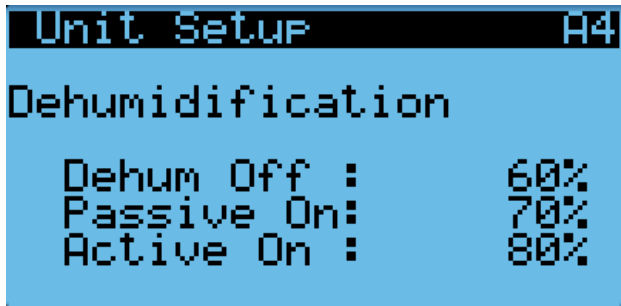

**Fan Control**

The LV has the option to change the continuous blower setting of the units connected to it. The options are All, Lead and None. If the option is set to All, then all of the units connected will run the blower continuously. If the option is set to Lead, only the unit in the lead position will run the blower continuously. If the option is set to None, then none of the units will run the blower continuously. When continuous blower doesn't apply to a unit, it will cycle the blower based on heating or cooling calls.

To adjust the continuous fan setting:

1. Press MENU key to go to the Main Menu screen.
2. Press UP or DOWN keys and ENTER key to enter USER password 2000.
3. Press UP or DOWN keys to scroll to **Sys Config**; press ENTER key.
4. Press UP or DOWN keys to scroll to **Unit Setup A1**; press ENTER key.
5. Press ENTER key to scroll to **Continuous Fan** (see Figure 44).
6. Press UP or DOWN keys to adjust value.
7. Press ENTER key to save.
8. Press the ESCAPE key several times to return to Main Menu screen.

**FIGURE 44**  
Adjusting Continuous Fan Setting

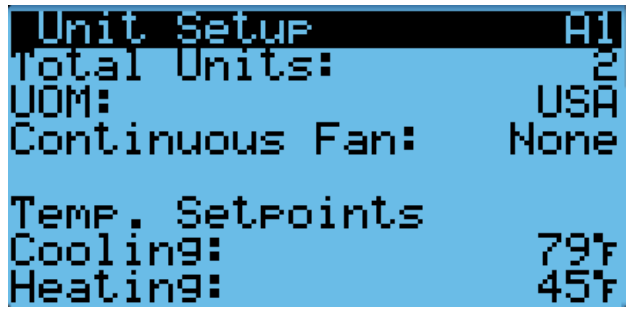

**Hour Counting**

The LV will keep track of each unit's heating and cooling method run times for last 24 hours (see Figure 45). In addition to how long an item was on, it will also track how many times a method started. These screens are located in the Quick Menu Info screens.

**FIGURE 45**  
Last 24 Hours Tracking



## 8403-079 Remote Indoor Temperature/Humidity Sensor

Troubleshooting the temperature/humidity sensor is necessary if the temperature or humidity reading for a zone is inaccurate. Always start sensor troubleshooting by verifying connections at the sensor board and at the LV1000 terminal blocks. Improper connection will cause inaccurate readings. Next, verify continuity at both ends of wires running between the sensor and the LV1000. A severed or damaged wire will cause inaccurate readings. As a last step, verify voltage and resistance at the sensor and the LV1000 terminal block per Tables 7 and 8 on the following pages. If the sensor is found to be malfunctioning, replace the sensor.

**FIGURE 46**  
**8403-079 Sensor**

Sensor Terminals	Description
M(GO) - +(G)	12VDC +/- Supplies power to the sensor
M(GO) - OUT H	0-1VDC Supplies signal for zone humidity (see Voltage/Humidity chart on page 37)
NTC OUT - NTC OUT	Ohm Supplies signal for zone temperature (see Temperature/Resistance chart on page 36)

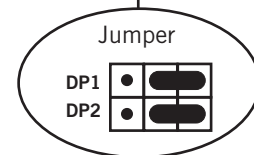
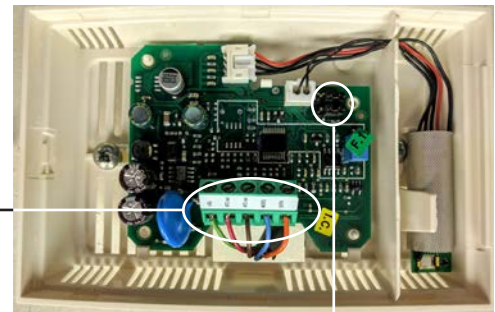

0-1VDC Jumper Position

**NOTE:** Sensor jumper must be positioned for 0-1 V as shown above for sensor to function properly.

Current versions of the 8403-079 remote indoor temperature/humidity sensor need to be installed with the shielded cable wires entering the bottom of the back of the sensor to connect to the sensor terminals as shown above in Figure 46. Earlier versions of this sensor were installed so that the sensor wires entered through the top of the back of the sensor. See **Remote Indoor Temperature/Humidity Sensor Orientation** on page 38 for more information.

**TABLE 7**  
**Temperature/Resistance of 8403-079 Sensor**

Temperature		Resistance	Temperature		Resistance	Temperature		Resistance
F	C	KΩ	F	C	KΩ	F	C	KΩ
25	-4	32.43	55	13	15.90	86	30	8.31
27	-3	31.04	57	14	15.28	88	31	8.01
28	-2	29.72	59	15	14.68	90	32	7.72
30	-1	28.47	61	16	14.12	91	33	7.45
32	0	27.28	63	17	13.57	93	34	7.19
34	1	26.13	64	18	13.06	95	35	6.94
36	2	25.03	66	19	12.56	97	36	6.69
37	3	23.99	68	20	12.09	99	37	6.46
39	4	22.99	70	21	11.63	100	38	6.24
41	5	22.05	72	22	11.20	102	39	6.03
43	6	21.15	73	23	10.78	104	40	5.82
45	7	20.29	75	24	10.38	106	41	5.63
46	8	19.40	77	25	10.00	108	42	5.43
48	9	18.70	79	26	9.63	109	43	5.25
50	10	17.96	81	27	9.28	111	44	5.08
52	11	17.24	82	28	8.94			
54	12	16.55	84	29	8.62			

**TABLE 8**  
**8403-079 Sensor: Voltage/Humidity**

Voltage DC	RH%	Voltage DC	RH%	Voltage DC	RH%
1	100	0.66	66	0.32	32
0.99	99	0.65	65	0.31	31
0.98	98	0.64	64	0.30	30
0.97	97	0.63	63	0.29	29
0.96	96	0.62	62	0.28	28
0.95	95	0.61	61	0.27	27
0.94	94	0.60	60	0.26	26
0.93	93	0.59	59	0.25	25
0.92	92	0.58	58	0.24	24
0.91	91	0.57	57	0.23	23
0.90	90	0.56	56	0.22	22
0.89	89	0.55	55	0.21	21
0.88	88	0.54	54	0.20	20
0.87	87	0.53	53	0.19	19
0.86	86	0.52	52	0.18	18
0.85	85	0.51	51	0.17	17
0.84	84	0.50	50	0.16	16
0.83	83	0.49	49	0.15	15
0.82	82	0.48	48	0.14	14
0.81	81	0.47	47	0.13	13
0.80	80	0.46	46	0.12	12
0.79	79	0.45	45	0.11	11
0.78	78	0.44	44	0.10	10
0.77	77	0.43	43	0.09	9
0.76	76	0.42	42	0.08	8
0.75	75	0.41	41	0.07	7
0.74	74	0.40	40	0.06	6
0.73	73	0.39	39	0.05	5
0.72	72	0.38	38	0.04	4
0.71	71	0.37	37	0.03	3
0.70	70	0.36	36	0.02	2
0.69	69	0.35	35	0.01	1
0.68	68	0.34	34	0.00	0
0.67	67	0.33	33		

**Remote Indoor Temperature/Humidity Sensor Orientation**

Current versions of the remote indoor temperature/humidity sensor need to be installed with the shielded cable wires entering the bottom of the back of the sensor to connect to the sensor terminals (see Figure 47). Earlier versions of this sensor were installed so that the sensor wires entered through the top of the back of the sensor (see Figure 48). **The orientation of the sensor affects the position of the DP1/DP2 jumpers. Depending on how the sensor is installed, be sure to confirm that the jumpers are in the proper position for the 0-1 V setting as shown in the figures below.**

**This applies to all indoor temperature/humidity sensors connected to the LV controller.** See illustration mounted inside of sensor cover for further detail on jumper position.

**FIGURE 47**  
**Current Sensor Orientation**  
**(Shielded Cable Wires Enter from Bottom)**

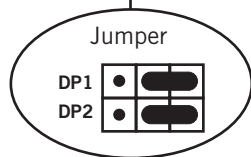
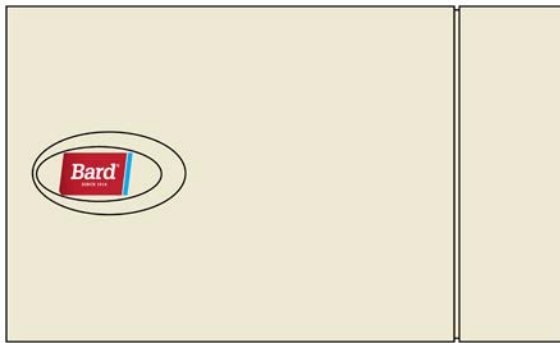

DP1 and DP2 Jumpers  
 Positioned for 0-1V  
 (Current Orientation)

**FIGURE 48**  
**Earlier Sensor Orientation**  
**(Shielded Cable Wires Enter from Top)**

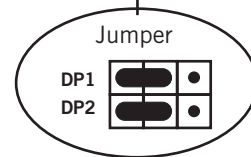
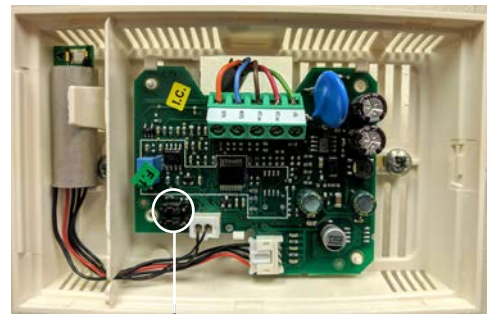
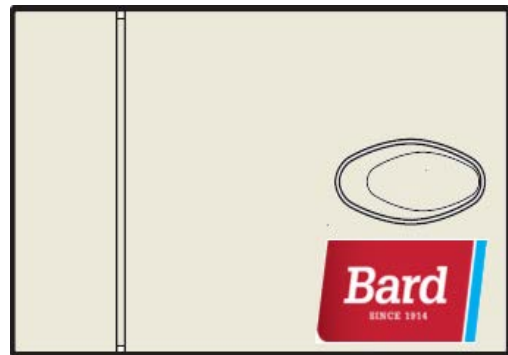

DP1 and DP2 Jumpers  
 Positioned for 0-1V  
 (Earlier Orientation)



# LV1000 MODBUS TCP REGISTER LIST

Version 1.1

For use with the following devices: LVS1000.1.1.0, LVS1000.1.1.1, LVS1000.2.0.0

## Input Registers (Read Only)

The following input registers reflect system inputs, operation variables and alarm setpoints for read-only purposes. (Units are represented as a whole number but include a single decimal place, i.e., a value of 600 through Modbus equals a value of 60.0 in the LV1000 system.)

Input Registers (Read Only System Values and Setpoints)	
Index	Description
0	Indoor Temperature Sensor 1
1	Indoor Temperature Sensor 2 (if used)
2	Indoor Temperature Sensor 3 (if used)
3	Indoor Temperature Average
4	Indoor Humidity Sensor 1
5	Indoor Humidity Sensor 2 (if used)
6	Indoor Humidity Sensor 3 (if used)
7	Indoor Humidity Average
10	Cooling Setpoint
11	Heating Setpoint
12	High Temperature Warning Setpoint
13	High Temperature Alarm Setpoint
14	Low Temperature Setpoint
16	Number of Units in System
17	Lead Unit in Rotation
18	Lag Unit 1 in Rotation
19	Lag Unit 2 in Rotation
20	Lag Unit 3 in Rotation

## Holding Registers (Read/Write)

The following holding registers reflect system setpoints that can be changed via Modbus TCP. (Units are represented as a whole number but include a single decimal place, i.e., a value of 600 through Modbus equals a value of 60.0 in the LV1000 system.)

Holding Registers (Writable Setpoints)	
Index	Description
0	Cooling Setpoint
1	Heating Setpoint
2	Low Temperature Setpoint
3	High Temperature Warning Setpoint
4	High Temperature Alarm Setpoint
5	Low Humidity Alarm Setpoint
6	High Humidity Alarm Setpoint
7	Free Cooling Outdoor Temperature Setpoint
8	Free Cooling Outdoor Humidity Setpoint
9	Free Cooling Outdoor Dew Point Setpoint
10	Modbus TCP Unit of Measure 0 = No Conversion 1 = SI 2 = US Customary 3 = Imperial 4 = Canadian Customary 5 = LON Units
11	1 = Unit Manual Rotation (Resets back to 0 after rotation)

## Discrete Inputs (Read Only)

The following discrete inputs reflect system alarms, major unit alarms and unit staging operations.

Discrete Inputs (Read Only Alarms and System Operation)	
Index	Description
0	= 1 when smoke alarm is active
1	= 1 when hydrogen alarm is active
2	= 1 when generator is running
3	= 1 when anti-theft (Bard Guard) is alarming
5	= 1 when indoor temp falls below Low Temp Alarm setpoint
6	= 1 when indoor temp rises above High Temperature Warning setpoint
7	= 1 when indoor temp rises above High Temperature Alarm setpoint
8	= 1 when HVAC Fail is detected on any unit
9	= 1 when HVAC Fail is condition is active on Unit 1
10	= 1 when HVAC Fail is condition is active on Unit 2
11	= 1 when HVAC Fail is condition is active on Unit 3
12	= 1 when HVAC Fail is condition is active on Unit 4
13	= 1 when any unit requires maintenance
14	= 1 when Unit 1 is detected by the LV1000
15	= 1 when Unit 2 is detected by the LV1000
16	= 1 when Unit 3 is detected by the LV1000
17	= 1 when Unit 4 is detected by the LV1000
20	= 1 when Unit 1 has a call for Free Cooling (if available)
22	= 1 when Unit 1 has a call for Cooling Stage 1
23	= 1 when Unit 1 has a call for Cooling Stage 2
26	= 1 when Unit 1 has a call for Free Heating Stage 1 (if available)
27	= 1 when Unit 1 has a call for Free Heating Stage 2 (if available)
28	= 1 when Unit 1 has a call for Free Heating Stage 3 (if available)
31	= 1 when Unit 2 has a call for Free Cooling (if available)
33	= 1 when Unit 2 has a call for Cooling Stage 1
34	= 1 when Unit 2 has a call for Cooling Stage 2
37	= 1 when Unit 2 has a call for Free Heating Stage 1 (if available)
38	= 1 when Unit 2 has a call for Free Heating Stage 2 (if available)
39	= 1 when Unit 2 has a call for Free Heating Stage 3 (if available)
42	= 1 when Unit 3 has a call for Free Cooling (if available)
44	= 1 when Unit 3 has a call for Cooling Stage 1
45	= 1 when Unit 3 has a call for Cooling Stage 2

**Discrete Inputs (Read Only) cont.**

Discrete Inputs (Read Only Alarms and System Operation)	
Index	Description
48	= 1 when Unit 3 has a call for Free Heating Stage 1 (if available)
49	= 1 when Unit 3 has a call for Free Heating Stage 2 (if available)
50	= 1 when Unit 3 has a call for Free Heating Stage 3 (if available)
53	= 1 when Unit 4 has a call for Free Cooling (if available)
55	= 1 when Unit 4 has a call for Cooling Stage 1
56	= 1 when Unit 4 has a call for Cooling Stage 2
59	= 1 when Unit 4 has a call for Free Heating Stage 1 (if available)
60	= 1 when Unit 4 has a call for Free Heating Stage 2 (if available)
61	= 1 when Unit 4 has a call for Free Heating Stage 3 (if available)
100	= 1 when Unit 1 Low Pressure Alarm is active
101	= 1 when Unit 1 High Pressure Cut-Out is active
102	= 1 when Unit 1 economizer damper failed to close
103	= 1 when Unit 1 economizer damper failed to open
104	= 1 when Unit 1 blower failure
200	= 1 when Unit 2 Low Pressure Alarm is active
201	= 1 when Unit 2 High Pressure Cut-Out is active
202	= 1 when Unit 2 economizer damper failed to close
203	= 1 when Unit 2 economizer damper failed to open
204	= 1 when Unit 2 blower failure
300	= 1 when Unit 3 Low Pressure Alarm is active
301	= 1 when Unit 3 High Pressure Cut-Out is active
302	= 1 when Unit 3 economizer damper failed to close
303	= 1 when Unit 3 economizer damper failed to open
304	= 1 when Unit 3 blower failure
400	= 1 when Unit 4 Low Pressure Alarm is active
401	= 1 when Unit 4 High Pressure Cut-Out is active
402	= 1 when Unit 4 economizer damper failed to close
403	= 1 when Unit 4 economizer damper failed to open
404	= 1 when Unit 4 blower failure

**TABLE 9**  
**LV1000-300 Terminal Block Index**

TB#	Wire Mark	Description
1	48+	48VDC +Input
2	48-	48VDC - Input
3	GND	Ground
4	24+	24VDC +
5	24-	24VDC -
6	24+	24VDC +
7	24-	24VDC -
8	DI1	Smoke Detector Input
9	GND	Smoke Detector Common
10	DI2	Hydrogen Detector Input
11	GND	Hydrogen Detector Common
12	DI3	Generator Run Input
13	GND	Generator Run Common
14	DI4	Anti Theft Input
15	GND	Anti Theft Common
16	DI5	Inverter Fault Input
17	GND	Inverter Fault Common
18	B2	Humidity Sensor 1
19	GND	Ground
20	B3	Humidity Sensor 2
21	GND	Ground
22	B4	Humidity Sensor 3
23	GND	Ground

TB#	Wire Mark	Description
24	B6	Remote Temperature Sensor 1
25	GND	Ground
26	B7	Remote Temperature Sensor 2
27	GND	Ground
28	B8	Remote Temperature Sensor 3
29	GND	Ground
30	VDC+	Humidity Sensor 1 +24VDC (B2)
31	VDC+	Humidity Sensor 2 +24VDC (B3)
32	VDC+	Humidity Sensor 3 +24VDC (B4)
33	VDC+	Spare Power +24VDC
34	NO1	Humidifier Output Relay
35	C1	Common
36	NO2	HVAC Fail
37	C1	Common
38	NO3	HVAC Maintenance
39	C1	Common
40	NO4	HVAC Anti Theft
41	C4	Common
42	FB1R-	RS485 RX- / TX- (Wall Units)
43	FB1R+	RS485 RX+ / TX+ (Wall Units)
44	FB2R-	RS485 RX- / TX- (Fieldbus 1)
45	FB2R+	RS485 RX+ / TX+ (Fieldbus 1)
46	-	Ground

**FIGURE 49**  
**LV1000-300 Wiring Diagram**

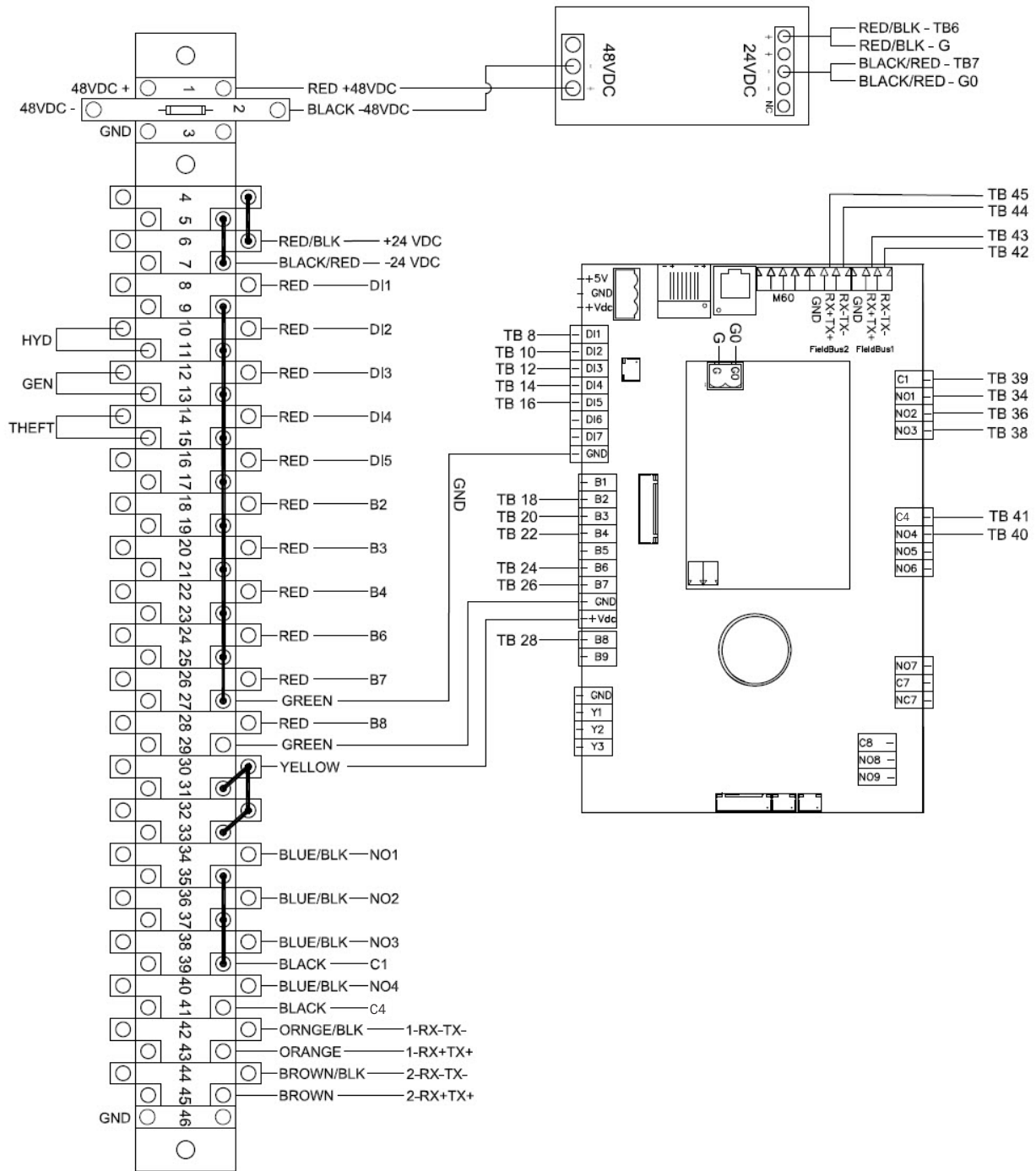



# LV1000 REPLACEMENT PARTS

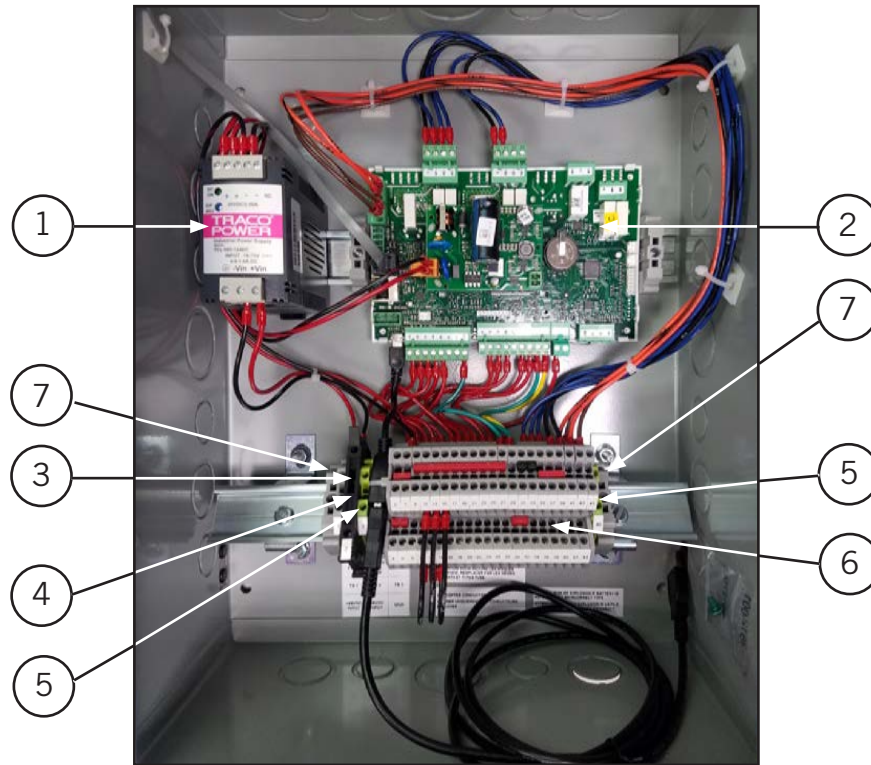

Dwg No.	Part Number	Description	LV1000
1	8301-082	17 – 75VDC to 24VDC Converter 2.5 Amps	1
2	8301-085-001* ①	UPC3-LV1000 Core 0	1
2	8301-098-001* ①	UPC3-LV1000 Core 2	1
3	8614-055	2.5 Amp Fuse	1
4	8607-039	Fused Terminal Block	1
5	8607-052	Grounded Terminal Block	2
6	8607-058	Terminal Block Double Level	21
7	8611-144	End Clamp (for din rail)	4
NS	8301-053	Panel Mounting Display Flush, pGDEvolution 132x64, Black Buttons with Cable	1
NS	3020-010	35' 2 Conductor 18 Gauge Cable	1
NS	8301-055	EMI Ferrite Filter	2
NS	8301-058	Remote Temperature Sensor ②	1
NS	8403-079	Remote Temperature/Humidity Sensor	1
NS	8301-059	TEC-EYE (Service Tool), 5' Telephone Cable	1
NS	3000-1587	5' Telephone Cable	1

\* Replacement part will have a letter attached to the end of the part number to designate software version (Example: 8301-085-001**A**). A software upgrade of all PLCs onsite (units and controllers) should accompany any PLC replacement. Latest revisions of software and instructions are available on the Bard website at <http://www.bardhvac.com/software-download/>.

① Previous LV1000 controllers (LV1000-100, -150, -200) use the Core 0 style PLC. The 8301-098-001 is the active replacement board for any future replacement parts. To identify the Core style of the PLC, see Figure 50 on page 46.

② Optional

NS – Not Shown

**FIGURE 50**  
**PLC Core Style Identification**

**Core 0**  
**Identifiers**

1. No Core Type ID on Capacitor or Core Type ID printed on white paper label
2. Software Version Label is printed on white paper Label
3. PLC Part Number Label is printed on white paper label

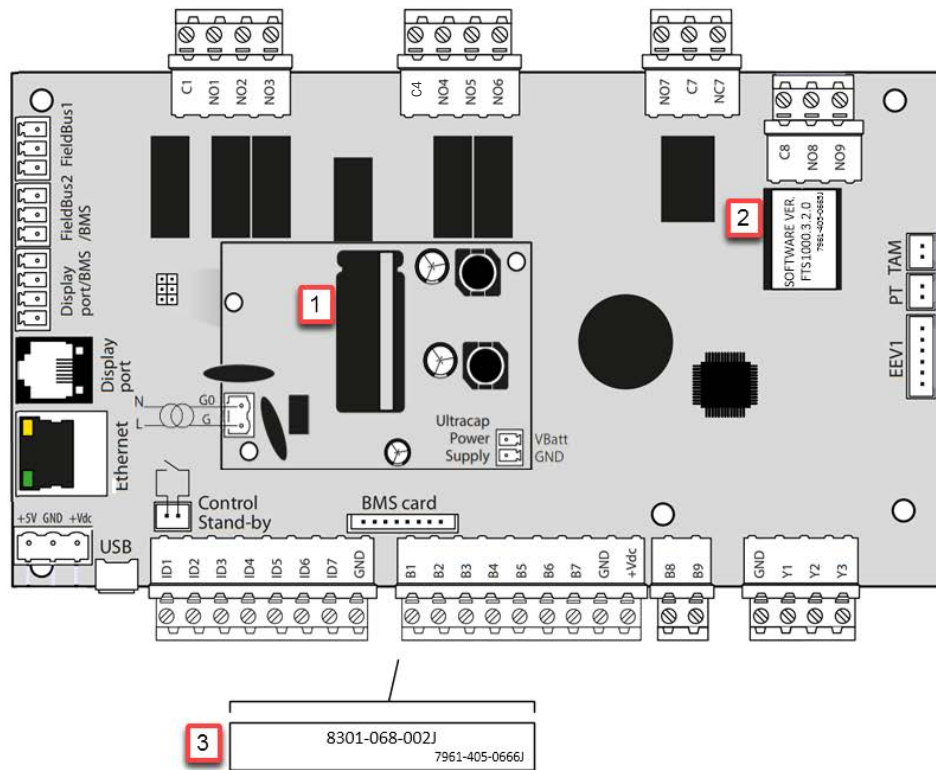

**Core 2**  
**Identifiers**

1. Core Type ID Label on Capacitor printed on yellow paper label
2. Software Version Label is printed on yellow paper Label
3. PLC Part Number Label is printed on yellow paper label

