

---

# INSTALLATION INSTRUCTIONS

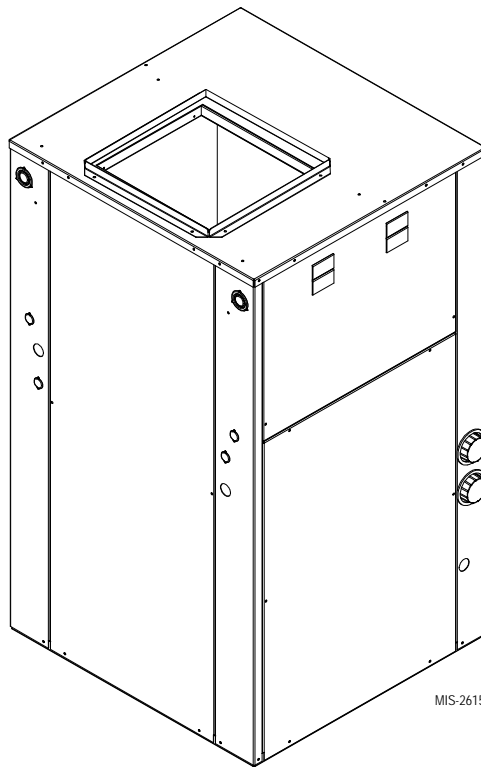
---

## Water Source Heat Pump

Models:

GV27S3AA GV38S3AA GV51S3AA GV61S3AA GV71S3AA

---



**Earth Loop Fluid Temperatures 25° – 110°**

**Ground Water Temperatures 45° – 75°**

---

BMC, Inc.  
Bryan, Ohio 43506

Manual: 2100-666E  
Supersedes: 2100-666D  
Date: 7-20-21

# CONTENTS

---

## Getting Other Informations and Publications ..3

### General Information ..... 4

Water Source Nomenclature .....	4
Heater Package Nomenclature .....	8

### Application and Location ..... 9

General .....	9
Shipping Damage .....	9
Application .....	9
Location .....	9
Ductwork .....	9
Filter .....	10
Condensate Drain .....	12
Piping Access to Unit.....	12

### Wiring Instructions..... 14

General .....	14
Control Circuit Wiring.....	14
Wall Thermostat .....	14
Thermostat Indicators .....	14
Emergency Heat Mode .....	14

### Ground Loop (Earth Coupled Water Loop Applications) ..... 16

Circulation System Design .....	16
Start Up Procedure for Ground Loop System .....	17

### Ground Water (Well System Applications) ..... 19

Water Connections .....	19
Well Pump Sizing .....	19
Start Up Procedure for Ground Water System .....	21
Water Corrosion .....	21
Remedies of Water Problems .....	22
Lake and Pond Installations.....	22

## Sequence of Operation ..... 24

Blower .....	24
Part Load Cooling .....	24
Full Load Cooling .....	24
Part Load Heating (No Electric Heat).....	24
Full Load Heating (No Electric Heat) .....	24
Supplementary Electric Heat .....	24
Emergency Heat Mode .....	24
Geothermal Logic Control .....	24
High Pressure Switch.....	25
Low Pressure Switch.....	25
Flow Switch .....	25
Evaporator Condensation Overflow .....	25
Under and Over Voltage Protection .....	25
Intelligent Reset.....	25
Alarm Output .....	25
Pressure Service Ports.....	25
System Start Up .....	25
Quick Reference Troubleshooting Chart.....	30

## Service ..... 31

Service Hints .....	31
Unbrazing System Components.....	31
Compressor Solenoid .....	31
Troubleshooting GE Endura Pro Series Motors .....	32

## Accessories ..... 34

Add-On GVDM-26 Pump Module Kit.....	34
General .....	34
Installation .....	34

## Ground Source Heat Pump Performance Report ..... 35

## Wiring Diagram ..... 37

---

## Figures

Figure 1	Unit Dimensions .....	7
Figure 2	Field Conversion to Left-Hand Return .....	10
Figure 3	Filter Rack – GV Models .....	12
Figure 4	Condensate Drain and Piping Access to Unit .....	13
Figure 5	Thermostat Wiring.....	15
Figure 6	Circulation System Design .....	16
Figure 7	Temperature and Pressure Measurement .....	17
Figure 8	Performance Model DORFC-1 Flow Center .....	18
Figure 9	Performance Model DORFC-2 Flow Center .....	18
Figure 10	Water Connection Components .....	20
Figure 11	Cleaning Water Coil.....	22
Figure 12	Lake and Pond Installation .....	23
Figure 13	Component Location .....	26
Figure 14	Control Panel.....	26
Figure 15	Refrigerant Flow Diagrams .....	27

Figure 16A	Pressure Tables.....	28
Figure 16B	Pressure Tables.....	29
Figure 17	Motor Connections .....	32
Figure 18	Motor Connections .....	33
Figure 19	Typical Pump Kit Connection to Unit.....	34

## Tables

Table 1	Indoor Blower Performance .....	4
Table 2	Flow Rates for Various Fluids .....	5
Table 3	Specifications.....	5
Table 4	Water Coil Pressure Drop .....	6
Table 5	Electrical Specifications – Optional Field-Installed Heater Packages .....	8
	Air Filter Table.....	11
Table 6	Control Circuit Wiring .....	14
Table 7	Wall Thermostat.....	14
Table 8A	Minimum Required Flow Rates for Ground Water Installations .....	19
Table 8B	Constant Flow Valves.....	19
Table 9	Solenoid Coil Resistance .....	31

---

---

## GETTING OTHER INFORMATION AND PUBLICATIONS

These publications can help with installing the heat pump. They can usually be found at the local library or purchased directly from the publisher. Be sure to consult the current edition of each standard.

National Electrical Code..... ANSI/NFPA 70

Standard for the Installation ..... ANSI/NFPA 90A  
of Air Conditioning and Ventilating Systems

Standard for Warm Air..... ANSI/NFPA 90B  
Heating and Air Conditioning Systems

Load Calculation for Residential .....ACCA Manual J  
Winter and Summer Air Conditioning

Duct Design for Residential ..... ACCA Manual D  
Winter and Summer Air Conditioning and Equipment  
Selection

Closed-Loop/Ground Source Heat Pump..... IGSHPA  
Systems Installation Guide

Grouting Procedures for Ground-Source ..... IGSHPA  
Heat Pump Systems

Soil and Rock Classification for ..... IGSHPA  
the Design of Ground-Coupled Heat Pump Systems

Ground Source Installation Standards..... IGSHPA

Closed-Loop Geothermal Systems..... IGSHPA  
– Slinky Installation Guide

### FOR MORE INFORMATION, CONTACT THESE PUBLISHERS:

**ACCA**     **Air Conditioning Contractors of America**  
1712 New Hampshire Avenue  
Washington, DC 20009  
Telephone: (202) 483-9370  
Fax: (202) 234-4721

**ANSI**     **American National Standards Institute**  
11 West Street, 13th Floor  
New York, NY 10036  
Telephone: (212) 642-4900  
Fax: (212) 302-1286

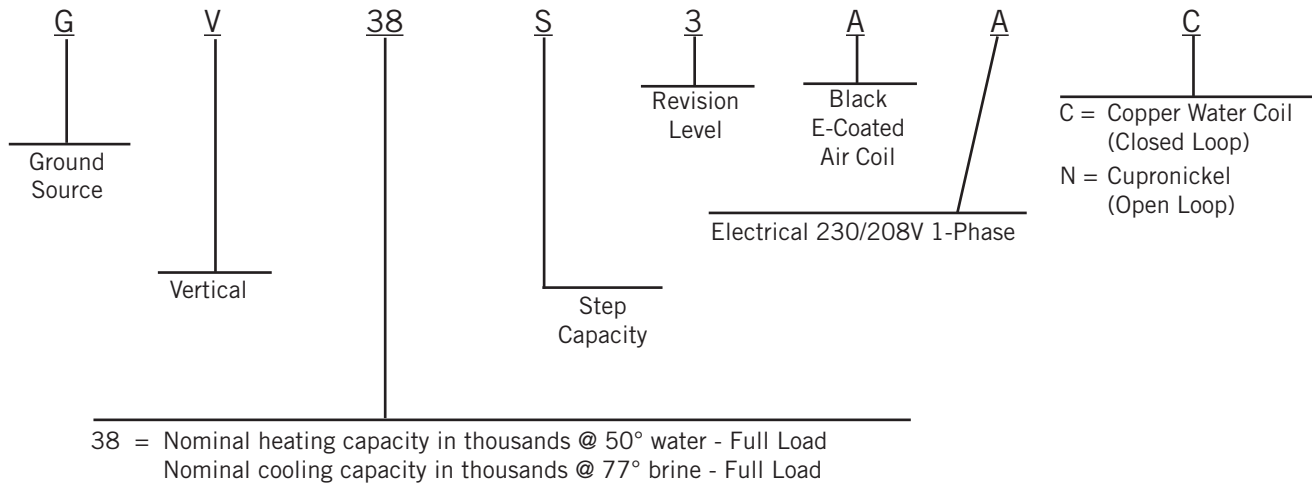
**ASHRAE**   **American Society of Heating Refrigerating,  
and Air Conditioning Engineers, Inc.**  
1791 Tullie Circle, N.E.  
Atlanta, GA 30329-2305  
Telephone: (404) 636-8400  
Fax: (404) 321-5478

**NFPA**     **National Fire Protection Association**  
Batterymarch Park  
P.O. Box 9101  
Quincy, MA 02269-9901  
Telephone: (800) 344-3555  
Fax: (617) 984-7057

**IGSHPA**   **International Ground Source  
Heat Pump Association**  
490 Cordell South  
Stillwater, OK 74078-8018

# GENERAL INFORMATION

## WATER SOURCE PRODUCT LINE NOMENCLATURE



**TABLE 1**  
**Indoor Blower Performance (Rated CFM) ①**

MODEL	Motor HP	② Rated ESP	③ MAX ESP	Speed #1	Speed #2	Speed #3	Speed #4	Speed #5
				④ Continuous Airflow	⑤ Mild Weather Operation in 1st Stage Cooling Mode (5-Min.)	⑥ Part Load Operation Airflow	⑦ -10% Full Load Airflow (Optional)	⑧ Full Load Airflow and Electric Heat Mode
GV27S3	1/3	0.15	0.50	500	650	800	900	1000
GV38S3	1/2	0.15	0.50	650	725	900	1175	1300
GV51S3	1/2	0.20	0.50	750	925	1150	1350	1500
GV61S3	3/4	0.20	0.50	800	1050	1300	1450	1600
GV71S3	3/4	0.25	0.50	875	1150	1450	1575	1750

- ① Motor will automatically step through the various airflows with thermostatic control.
- ② ESP = External Static Pressure (inches of water)
- ③ Maximum allowable duct static
- ④ Continuous airflow is the CFM being circulated with manual fan operation without any additional function occurring.
- ⑤ Will occur automatically for first 5 minutes of Part Load Cooling Operation.
- ⑥ Will occur automatically after five minutes of Part Load Cooling Operation.
- ⑦ This is a field option for noisy installations to de-rate Full Load airflow (requires change in control panel).
- ⑧ Will occur automatically with control signal input (will not be defeated for electric heat operation).

**TABLE 2A**  
**Rated Flow Rates for Various Fluids**

Various Fluids	MODELS				
	GV27S	GV38S	GV51S	GV61S	GV71S
Flow rate required GPM fresh water ①	7	9	12	15	16
Flow rate required GPM 15% Sodium Chloride	7	9	12	15	16
Flow rate required GPM 25% GS4	7	9	12	15	16

① Rated Flow

**TABLE 2B**  
**Optional Ground Water Flow Rates**

Fresh Water	MODELS				
	GV27S	GV38S	GV51S	GV61S	GV71S
Optional Pump-N-Dump Flow Rates	5	6	7	9	10

**TABLE 3**  
**Specifications**

MODEL	GV27S3AA*	GV38S3AA*	GV51S3AA*	GV61S3AA*	GV71S3AA*
Electrical Rating (60HZ/1PH)	230/208-1	230/208-1	230/208-1	230/208-1	230/208-1
Operating Voltage Range	253-197	253-197	253-197	253-197	253-197
Minimum Circuit Ampacity ①	19	24	32	40	44
+Field Wire Size ①	#12	#10	#8	#6	#6
Delay Fuse Max. or Ckt. Bkr. ①	30	40	50	60	70
<b>COMPRESSOR</b>					
Volts	230/208	230/208	230/208	230/208	230/208
Rated Load Amps 230/208	7.5/8.6	12.0/13.65	15.8/17.6	21.9/24.2	26.3/28.9
Branch Ckt. Selection Current	11.7	15.3	21.2	27.2	29.7
Lock Rotor Amps 230/208	58.3/58.3	83/83	104/104	152.9/152.9	179.2/179.2
<b>BLOWER MOTOR AND EVAPORATOR</b>					
Blower Motor - HP/Speed/Type	1/3 / 5 / ECM	1/2 / 5 / ECM	1/2 / 5 / ECM	3/4 / 5 / ECM	3/4 / 5 / ECM
Blower Motor - Amps	1.5 / 1.6	2.5 / 2.95	2.8 / 3.0	3.8 / 4.1	4.1 / 4.2
Face Area Sq. Ft./Row/Fins Per Inch	3.16 / 4 / 11	3.16 / 4 / 11	5.33 / 3 / 11	5.33 / 4 / 11	5.33 / 5 / 10

+75°C copper wire

\* C - for copper / N for Cupronickel water coil

① Heat pump only. Optional field-installed heaters are separate circuit.

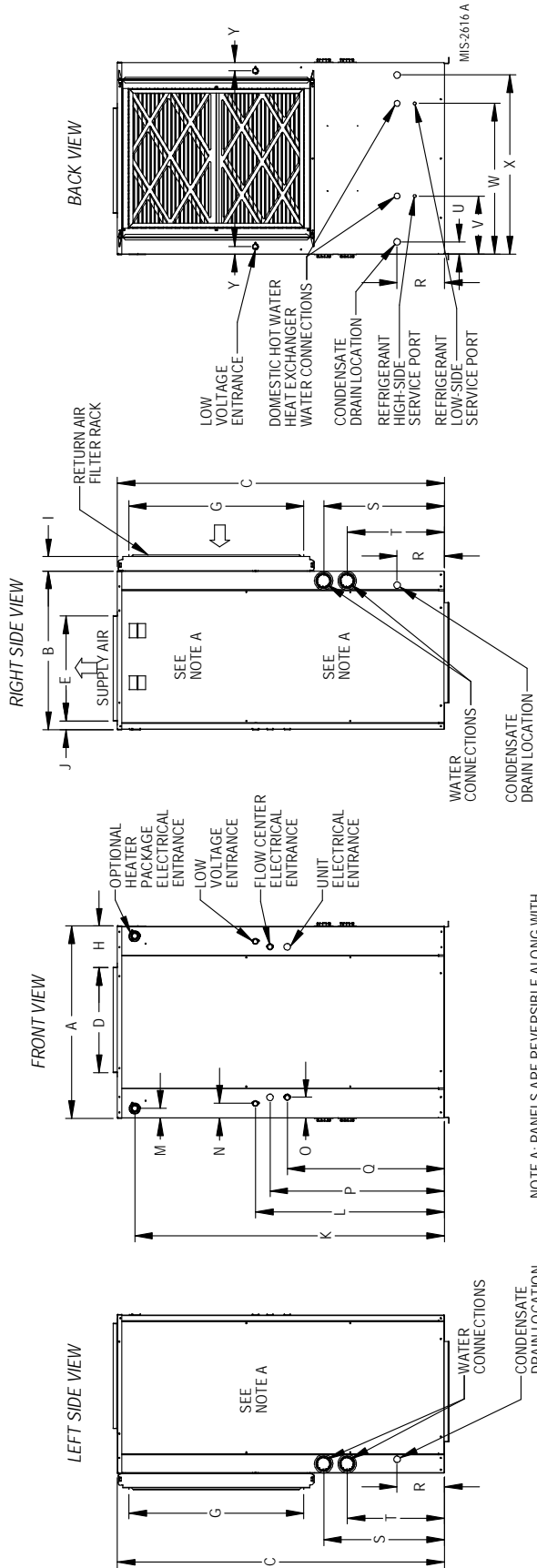
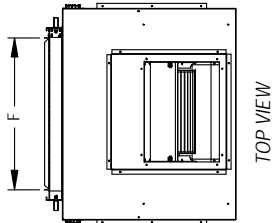
**TABLE 4**  
**Water Coil Pressure Drop**

Model GPM	GV27S3		GV38S3 / GV51S3		GV61S3		GV71S3	
	PSID	Ft. Hd.	PSID	Ft. Hd.	PSID	Ft. Hd.	PSID	Ft. Hd.
3	0.1	0.23						
4	0.5	1.15	0.9	2.08				
5	1.2	2.77	1.4	3.23				
6	1.7	3.92	2.3	5.31				
7	2.3	5.31	3.2	7.38	2	4.61		
8	3.1	7.15	4.1	9.46	2.5	5.77	2	4.61
9	4.1	9.46	5.1	11.77	3.2	7.38	2.4	5.54
10			6.1	14.07	3.9	9.00	2.8	6.46
11			7.1	16.38	4.7	10.84	3.4	7.84
12			8.2	18.92	5.5	12.69	3.9	9.00
13			9.4	21.69	6.4	14.76	4.5	10.38
14			10.6	24.45	7.3	16.84	5.2	12.00
15					8.1	18.69	5.9	13.61
16					9	20.76	6.7	15.46
17					9.9	22.84	7.4	17.07
18							8.4	19.38

**FIGURE 1**  
Unit Dimensions

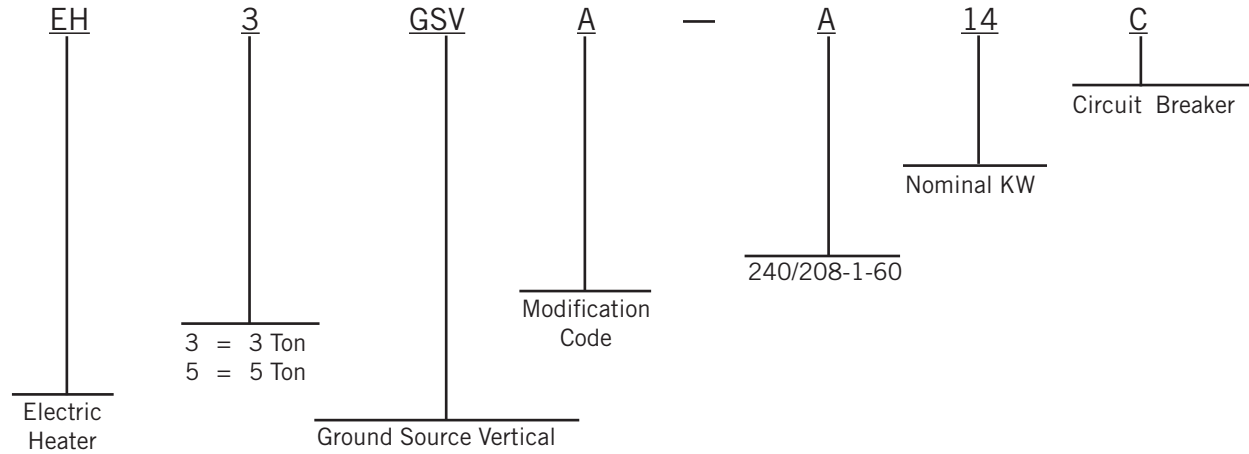
Units	Width		Depth		Supply		Return	
	A	B	C	Height	Duct	Flange	Width	Height
GV27-38S3	27-5/8	26	48		13-7/8	13-7/8	18	22-3/4
GV51-71S3	32-5/8	27	55-5/8		17-7/8	17-7/8	23-1/2	29-7/8

	H	I	J	K	L	M	N	O	P	Q	R	S	T	U	V	W	X	Y
	6-7/8	2-7/16	1-1/2	45-1/4	31-5/8	1-5/8	2-1/4	3-1/4	29-1/16	25-13/16	8-3/16	19-1/2	15-1/2	2-1/16	7-3/8	23-1/8	25-7/16	1-1/4
	7	2-7/16	1-1/2	52-7/8	32-1/4	1-5/8	2-1/2	3-1/2	29-3/4	26-13/16	8-1/16	19-5/16	15-5/16	2-1/16	9-7/8	25-5/8	30-7/16	1-5/16



NOTE A: PANELS ARE REVERSIBLE ALONG WITH CONTROL PANELS FOR HEAT PUMP AND ELECTRIC HEATER PACKAGE FOR BEST INSTALLATION POSITION.

## HEATER PACKAGE NOMENCLATURE



**TABLE 5**  
**Electrical Specifications – Optional Field-Installed Heater Packages**

For Use with Models	Heater Package Model No.	Heater Package Volts/Phase 60 HZ	Heater Amps, KW and Capacity @ 240 Volts			Heater Amps, KW and Capacity @ 208 Volts			Minimum Circuit Ampacity	Maximum Circuit Breaker	Field Wire Size+
			AMPS	KW	BTU	AMPS	KW	BTU			
GV27S3AA GV38S3AA	EH3GSVA-A05C	240/208-1	18.8	4.5	15,345	16.3	3.38	11,525	23.5	25	10
	EH3GSVA-A09C	240/208-1	37.5	9.0	30,690	32.5	6.75	23,018	46.9	50	8
	EH3GSVA-A14C	240/208-1	56.3	13.5	46,035	48.7	10.13	34,543	70.4	80	4
GV51S3AA GV61S3AA GV71S3AA	EH5GSVA-A09C	240/208-1	37.5	9.0	30,690	32.5	6.75	23,018	46.9	50	8
	EH5GSVA-A14C	240/208-1	56.3	13.5	46,035	48.7	10.13	34,543	70.4	80	4
	EH5GSVA-A18C	240/208-1	75.0	18.0	61,380	64.9	13.5	46,035	98.3	100	3

+ Based on 75F copper wire. All wiring must conform to National Electrical Code (latest edition) and all local codes.



# APPLICATION AND LOCATION

## GENERAL

Units are shipped completely assembled and internally wired, requiring only duct connections, thermostat wiring, 230/208 volt AC power wiring and water piping. The equipment covered in this manual is to be installed by trained, experienced service and installation technicians.

These instructions and any instructions packaged with any separate equipment required to make up the entire heat pump system should be carefully read before beginning the installation. Note particularly any tags and/or labels attached to the equipment.

While these instructions are intended as a general recommended guide, they do not in any way supersede any national and/or local codes. Authorities having jurisdiction should be consulted before the installation is made.

## SHIPPING DAMAGE

Upon receipt of the equipment, the carton should be checked for external signs of shipping damage. If damage is found, the receiving party must contact the last carrier immediately, preferably in writing, requesting inspection by the carrier's agent.

## APPLICATION

Capacity of the unit for a proposed installation should be based on heat loss calculations made in accordance with methods of the Air Conditioning Contractors of America. The air duct system should be sized and installed in accordance with Standards of the National Fire Protection Association for the Installation of Air Conditioning and Venting systems of Other than Residence Type NFPA No. 90A and Residence Type Warm Air Heating and Air Conditioning Systems NFPA No. 90B.

## LOCATION

The unit may be installed in a basement, closet or utility room provided adequate service access is ensured. The unit is shipped from the factory as a right-hand return and requires **access clearance of 2' minimum to the access panels on this side of the unit.** If unit is to be field converted to left-hand return the opposite side will require access clearance of 2' minimum.

Unit may be field converted to left-hand return by removing two (2) screws that secure the control panel cover, removing four (4) screws that hold the control panel in place, laying the control panel down, sliding it under the blower and re-securing the control panel on

the opposite side of the unit (see Figure 2 on page 10). The two access doors from the right-hand return can be transferred to the left-hand return side and the one left-hand panel can be transferred to the right-hand side.

Unit casing suitable for 0" clearance with 1" duct clearance for at least the first 3' of duct. These units are not approved for outdoor installation and therefore must be installed inside the structure being conditioned. **Do not locate in areas subject to freezing in the winter or subject to sweating in the summer.**

Before setting the unit, consider ease of piping, drain and electrical connections for the unit. Also, for units which will be used with a field-installed heat recovery unit, consider the proximity of the unit to the water heater or storage tank. Place the unit on a solid base, preferably concrete, to minimize undesirable noise and vibration. **DO NOT** elevate the base pan on rubber or cork vibration eliminator pads as this will permit the unit base to act like a drum, transmitting objectionable noise.

## DUCTWORK

If the unit is to be installed in a closet or utility room which does not have a floor drain, a secondary drain pan under the entire unit is highly recommended.

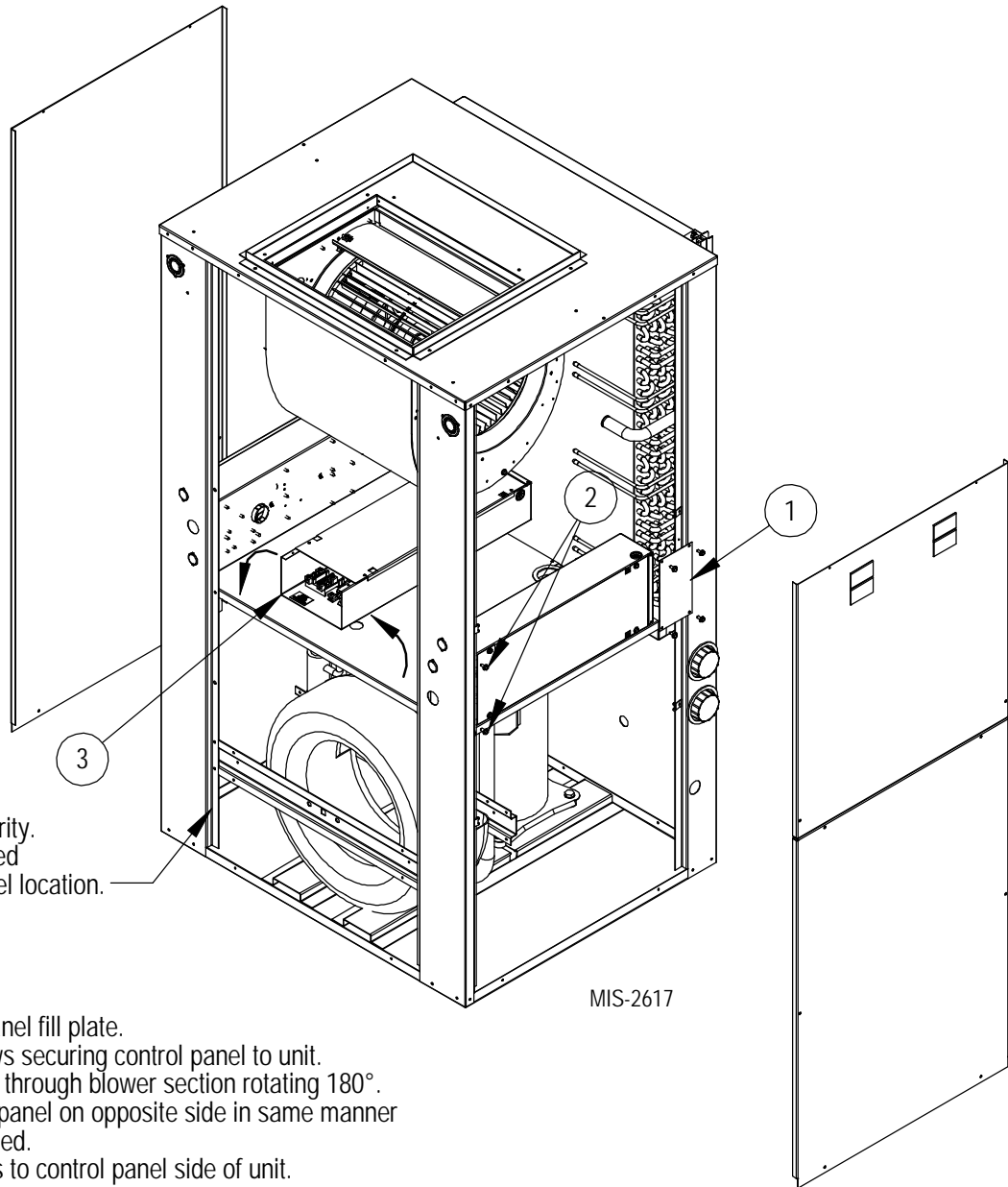
**DO NOT** install the unit in such a way that a direct path exists between any return grille and the unit. Rather, insure that the air entering the return grille will make at least one turn before entering the unit or coil. This will reduce possible objectionable compressor and air noise from entering the occupied space.

Design the ductwork according to methods given by the Air Conditioning Contractors of America. When duct runs through unconditioned spaces, it should be insulated with vapor barrier. It is recommended that flexible connections be used to connect the ductwork to the unit in order to keep the noise transmission to a minimum.

## WARNING

Failure to provide the 1" clearance between the supply duct and a combustible surface for the first 3' of duct can result in a fire.

**FIGURE 2**  
**Field Conversion to Left-Hand Return**



Panel removed for clarity.  
 Does not need removed  
 to change control panel location.

1. Remove control panel fill plate.
2. Remove two screws securing control panel to unit.
3. Pass control panel through blower section rotating 180°.
4. Re-secure control panel on opposite side in same manner as originally attached.
5. Move double doors to control panel side of unit.

**FILTER**

This unit must not be operated without a filter. It comes equipped with 2" disposable filters, which should be checked often and replaced if dirty. Insufficient airflow due to undersized duct systems or dirty filters can result in nuisance tripping of the high or low pressure controls. Refer to Table 1 on page 4 for correct airflow and static pressure requirements.

**NOTE:** The filter rack is installed on the unit as shipped for right-hand return. If left-hand return is required, remove the filter access door and screws holding the filter rack to the unit (slide downward from underneath unit top). Invert the filter rack 180° to move filter

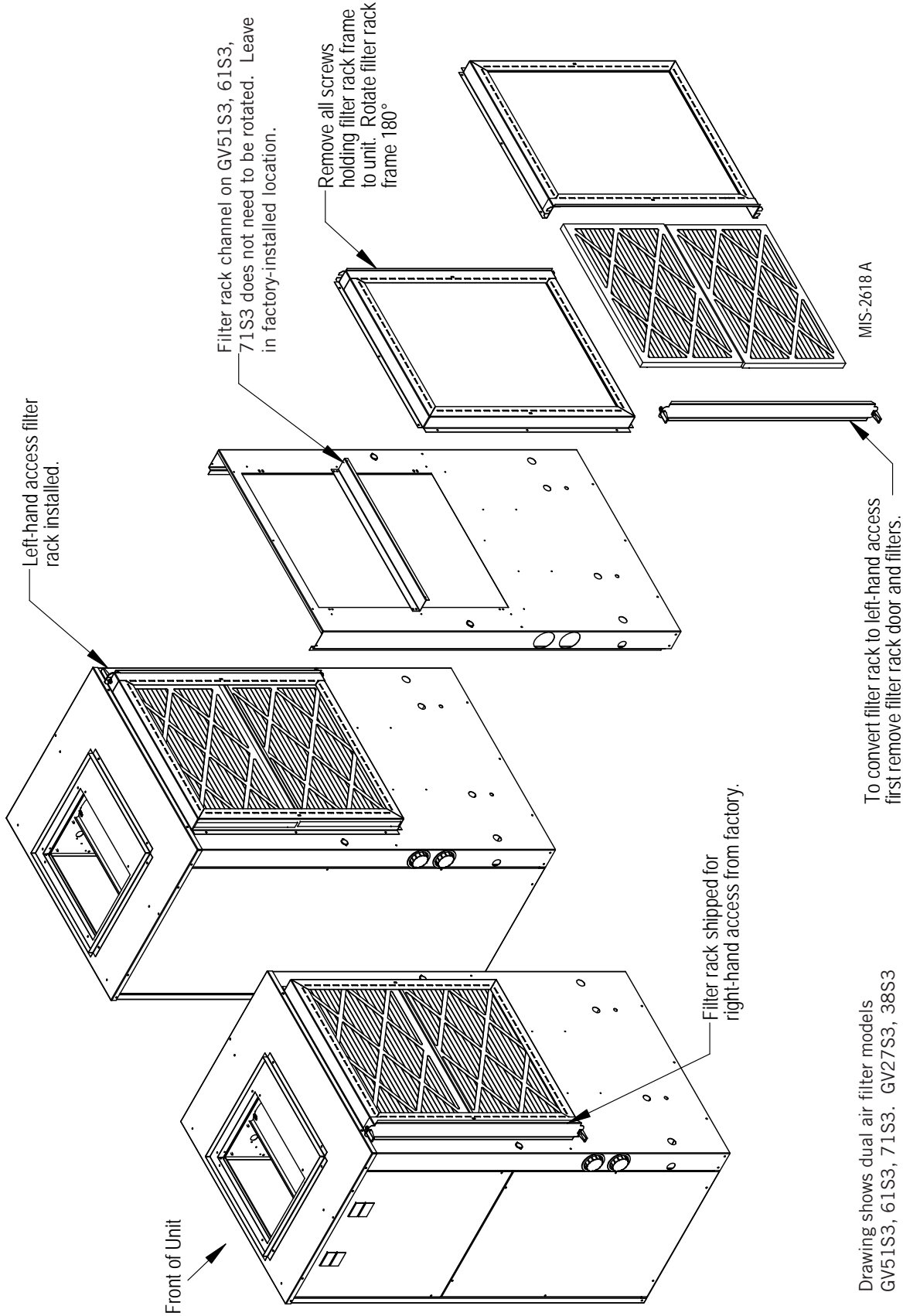
access door to the other side of the unit, and reverse the previous steps (see Figure 3).

**NOTE:** The duct attachment flanges will need to be bent up using duck bill pliers or similar device, as the unit is shipped with them collapsed.

**Air Filters**

Model	Filter Size	Quantity
GV27S GV38S	20" x 25" x 2"	1
GV51S GV61S GV71S	16" x 25" x 2"	2

**FIGURE 3**  
**Filter Rack – GV Models**



Drawing shows dual air filter models GV51S3, 61S3, 71S3. GV27S3, 38S3 have only one air filter.

## CONDENSATE DRAIN

Drain lines must be installed according to local plumbing codes. It is not recommended that any condensate drain line be connected to a sewer main.

Determine where the drain line will run and then select one of four locations for the condensate to exit the unit casing (see Figure 4). There are knockouts in the unit casing that can be selected for the condensate exit. Internal of the unit, there is a clear flexible hose with a termination fitting installed. When installed properly, this hose will create a trap internal of the unit and will remain serviceable if the drain system requires cleaning or service. Supplied in the parts bag of the unit is a 3/4" PVC male adaptor that will secure the internal drain components to the sheet metal casing at the location selected.

**NOTE:** *This drain line will contain cold water and must be insulated to avoid droplets of water from condensing on the pipe and dripping on finished floors or the ceiling below the unit.*

## PIPING ACCESS TO UNIT

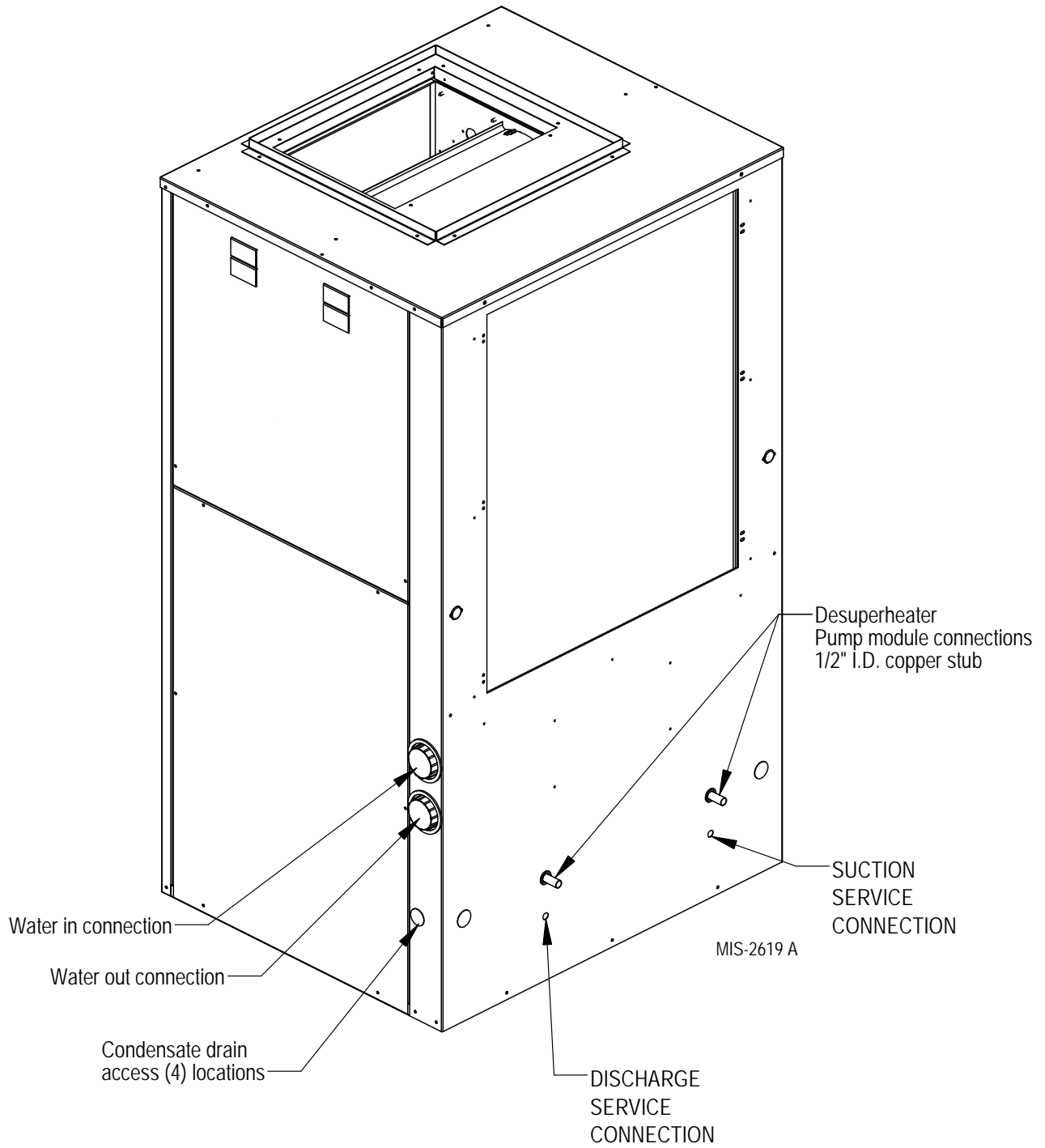
Water piping to and from the unit enters the unit cabinet on either side of the unit. The connection directly at the unit is a special double O-ring fitting with a retainer nut that secures it in place. (It is the same style fitting used for the flow center connection on ground loop applications.) Enter in and out either side of the unit in any combination as the installation dictates. One side has both connections closed off with a double O-ring plug seal with retaining caps. One or both of these can be transferred to the opposite side, depending upon installation requirements.

**NOTE:** *All double O-ring fittings require "hand tightening only". Do not use wrench or pliers as retainer nut can be damaged with excessive force.*

**NOTE:** *Apply petroleum jelly to O-rings to prevent damage and aid in insertion.*

Various fittings are available to connect to the unit with various materials and methods. These methods include 1" barbed fittings (straight and 90°), 1" MPT (straight and 90°), and 1-1/4" hot fusion fitting (straight only) (see Figure 4).

**FIGURE 4**  
**Condensate Drain and Piping Access to Unit**



# WIRING INSTRUCTIONS

## GENERAL

All wiring must be installed in accordance with the National Electrical Code and local codes. In Canada, all wiring must be installed in accordance with the Canadian Electrical Code and in accordance with the regulations of the authorities having jurisdiction. Power supply voltage must conform to the voltage shown on the unit serial plate. A wiring diagram of the unit is attached to the inside of the electrical cover. The power supply shall be sized and fused according to the specifications supplied. A ground lug is supplied in the control compartment for equipment ground.

The unit rating plate lists a maximum circuit breaker or fuse that is to be used with the equipment. The correct size must be used for proper circuit protection and also to assure that there will be no nuisance tripping due to the momentary high starting current of the compressor motor.

## CONTROL CIRCUIT WIRING

The minimum control circuit wiring gauge needed to ensure proper operation of all controls in the unit will depend on two factors.

1. The rated VA of the control circuit transformer.
2. The maximum total distance of the control circuit wiring.

Table 6 should be used to determine proper gauge of control circuit wiring required.

**TABLE 6**  
**Control Circuit Wiring**

Rated VA of Control Circuit Transformer	Transformer Secondary FLA @ 24V	Maximum Total Distance of Control Circuit Wiring in Feet
50	2.1	20 gauge – 45 18 gauge – 60 16 gauge – 100 14 gauge – 160 12 gauge – 250

*Example:*

1. Control circuit transformer rated at 50 VA
2. Maximum total distance of control circuit wiring 85'

Per Table 6, minimum of 16 gauge wire should be used in the control circuit wiring.

## WALL THERMOSTAT

The following thermostat should be used as indicated, depending on the application.

**TABLE 7**  
**Wall Thermostat**

Thermostat	Predominant Features
8403-060 (1120-445)	3 stage Cool; 3 stage Heat Programmable/Non-Programmable Electronic HP or Conventional Auto or Manual changeover

## THERMOSTAT INDICATORS

8403-060 (1120-445) Temperature/Humidity Control:

In heating or cooling, the display may be black and light gray, or backlit in blue depending on configuration. In the event of a system malfunction such as a loss of charge or high head pressure, the heat pump control board will issue a signal to the thermostat causing the screen to be backlit in RED and the display to read "Service Needed". If this occurs, the control will continue to function, but adjustments will not be able to be made until the problem is corrected and the fault device is reset.

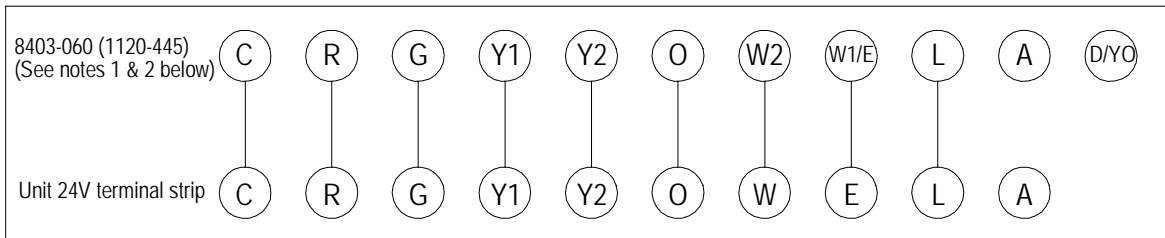
## EMERGENCY HEAT MODE

The operator of the equipment must manually place the system switch in this mode. This is done when there is a known problem with the unit.

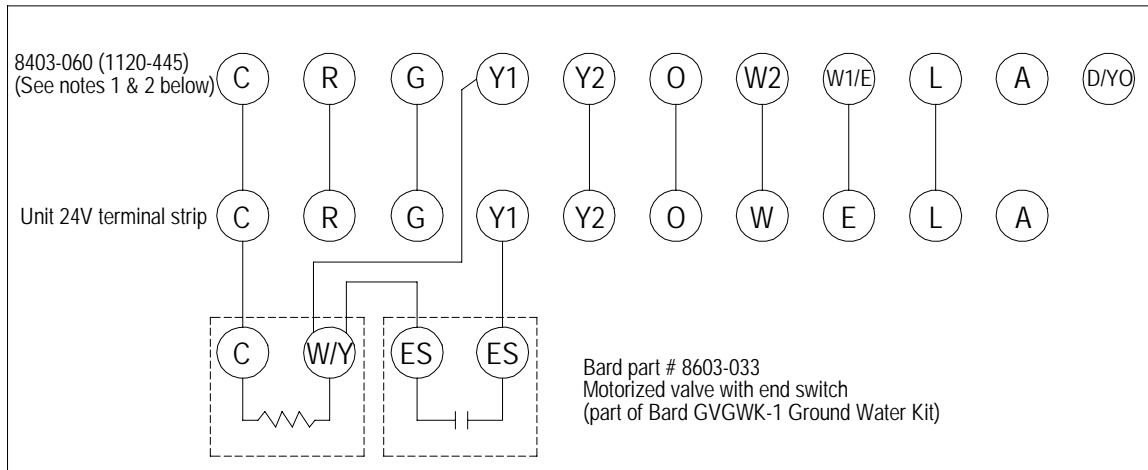
When the 8403-060 (1120-445) Temperature/Humidity Control is placed in the Emergency Heat mode, the display will be backlit in RED to indicate that service is needed. The display will remain backlit in red until the mode is switched out of Emergency Heat.

**FIGURE 5**  
**Thermostat Wiring**

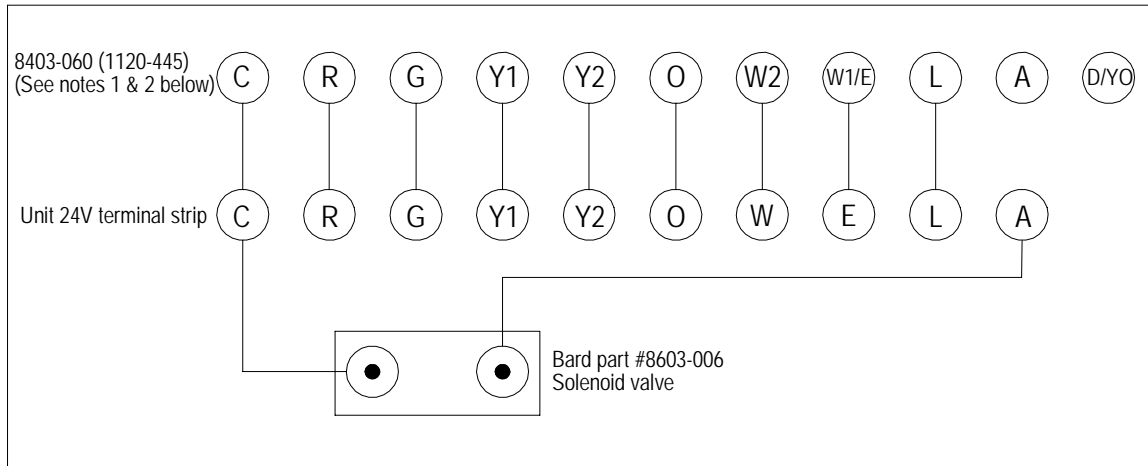
GROUND LOOP APPLICATIONS (when utilized with a flow center)



GROUND WATER APPLICATIONS (when installed with recommended motorized valve with end switch)



GROUND WATER APPLICATIONS (when installed with standard 2-wire solenoid valve)



1. Will need to be programmed for multi-stage heat pump
2. Will need to be configured to energize reversing valve for cooling mode
3. All wiring field supplied low voltage

MIS-2620 E

# GROUND LOOP (EARTH COUPLED WATER LOOP APPLICATIONS)

**NOTE: Unit shipped from factory with 60 PSIG low pressure switch wired into control circuit and must be rewired to 45 PSIG low pressure switch for ground loop applications.** This unit is designed to work on earth coupled water loop systems, however, these systems operate at entering water (without antifreeze) temperature with pressures well below the pressures normally experienced in water well systems.

## CIRCULATION SYSTEM DESIGN

Equipment room piping design is based on years of experience with earth coupled heat pump systems. The design eliminates most causes of system failure.

The heat pump itself is rarely the cause. Most problems occur because designers and installers forget that a ground loop “earth coupled” heat pump system is NOT like a household plumbing system.

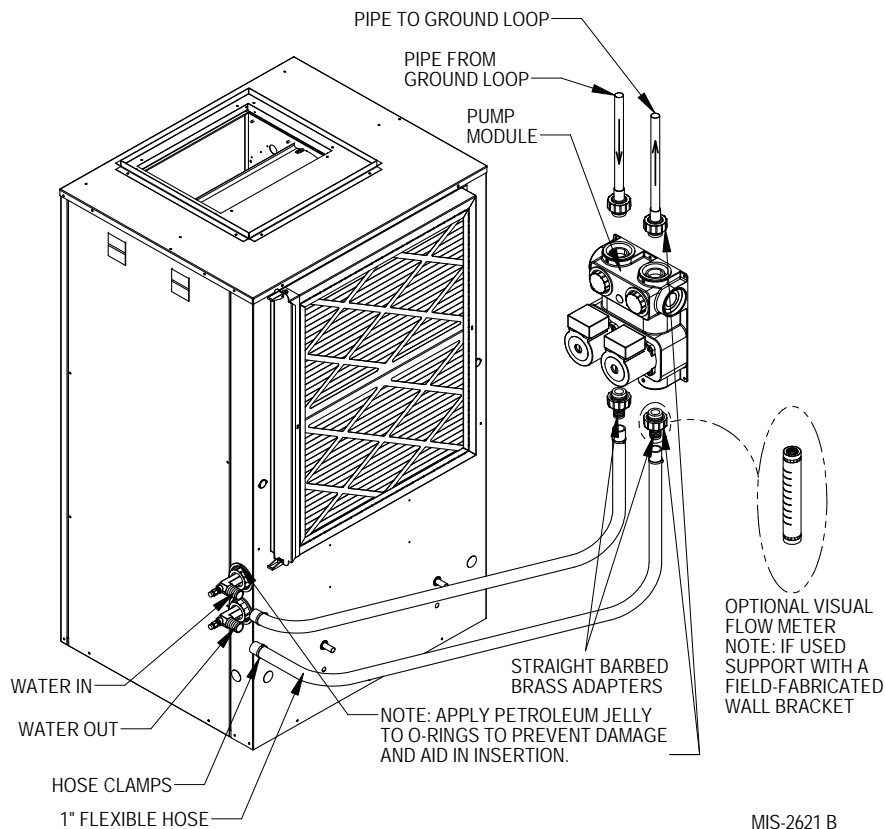
Most household water systems have more than enough water pressure either from the well pump or the municipal water system to overcome the pressure

of head loss in 1/2" or 3/4" household plumbing. A closed loop earth coupled heat pump system, however, is separated from the pressure of the household supply and relies on a small, low wattage pump to circulate the water and antifreeze solution through the earth coupling, heat pump and equipment room components.

The small circulator keeps the operating costs of the system to a minimum. However, the performance of the circulator MUST be closely matched with the pressure of head loss of the entire system in order to provide the required flow through the heat pump. Insufficient flow through the heat exchanger is one of the most common causes of system failure. Proper system piping design and circulator selection will eliminate this problem.

The equipment supplier may provide a worksheet to simplify heat loss calculations and circulator selection. Refer to “Circulating Pump Worksheet” section.

**FIGURE 6  
Circulation System Design**

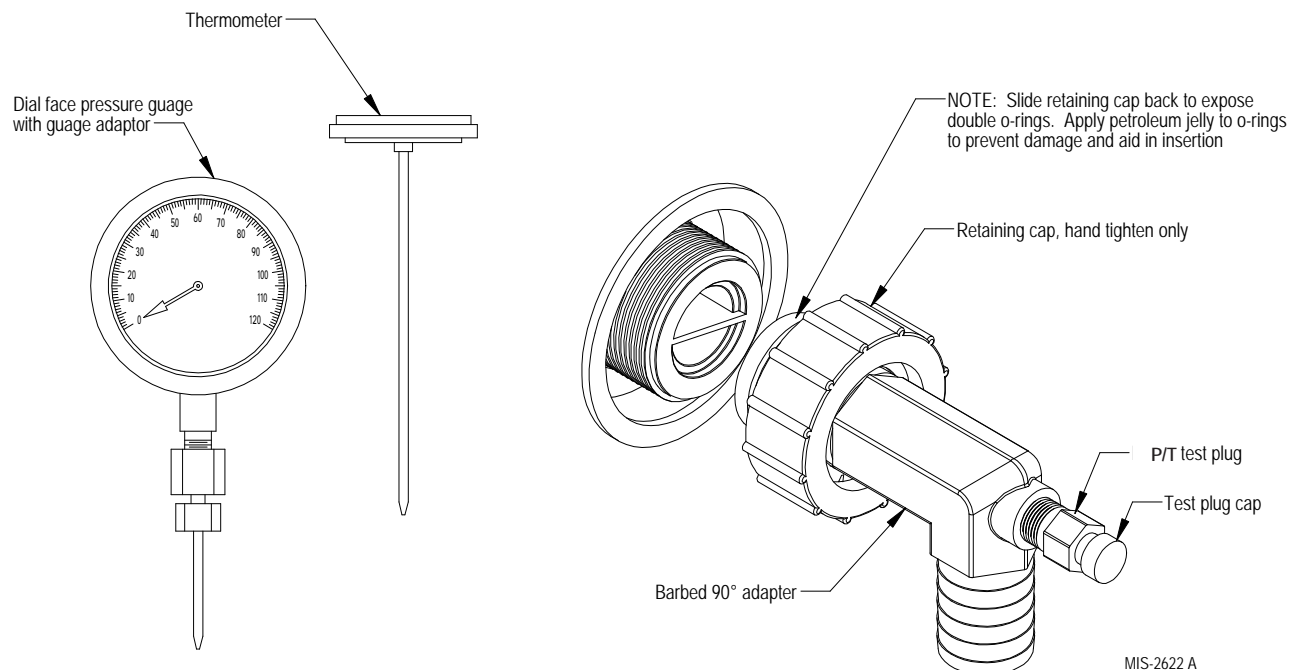




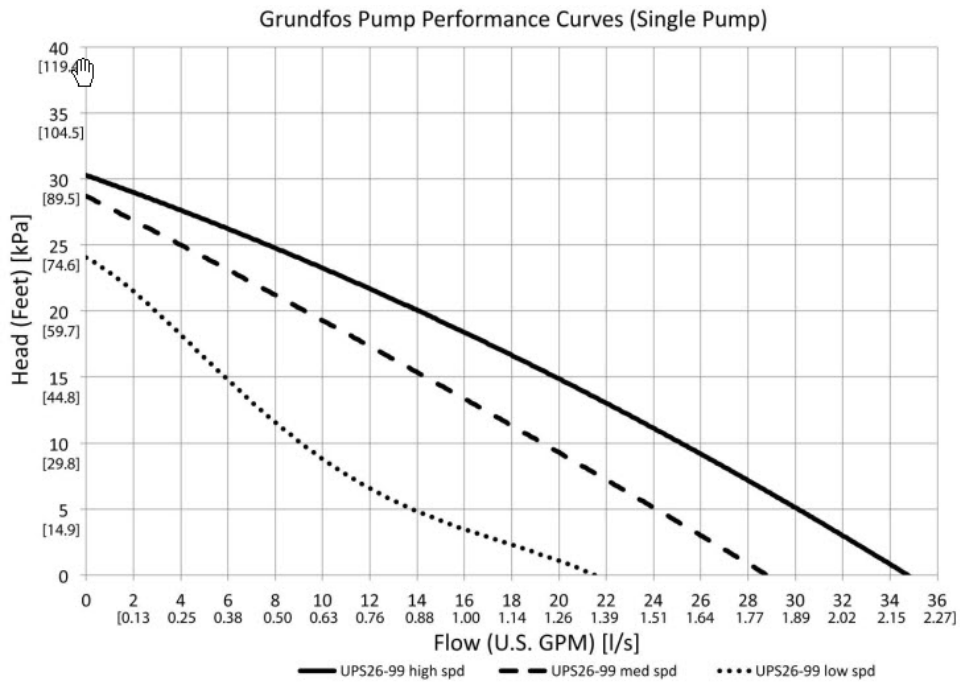
## START UP PROCEDURE FOR GROUND LOOP SYSTEM

1. Be sure main power to the unit is OFF at disconnect.
  2. Set thermostat system switch to OFF and fan switch to AUTO.
  3. Move main power disconnect to ON. Except as required for safety while servicing, **DO NOT OPEN THE UNIT DISCONNECT SWITCH.**
  4. Check system airflow for obstructions.
    - A. Move thermostat fan switch to ON. Blower runs.
    - B. Be sure all registers and grilles are open.
    - C. Move thermostat fan switch to AUTO. Blower should stop.
  5. Flush, fill and pressurize the closed loop system as outlined.
  6. Fully open the manual inlet and outlet valves. Start the loop pump module circulator(s) and check for proper operation. If circulator(s) are not operating, turn off power and diagnose the problem.
  7. Check fluid flow using a direct reading flow meter or a single water pressure gauge; measure the pressure drop at the pressure/temperature plugs across the water coil. Compare the measurement with flow versus pressure drop table to determine the actual flow rate. If the flow rate is too low,
    8. Start the unit in cooling mode by moving the thermostat switch to cool. Fan should be set for AUTO.
    9. Check the system refrigerant pressures against the cooling refrigerant pressure table in the installation manual for rated water flow and entering water temperatures. If the refrigerant pressures do not match, check for airflow problem then refrigeration system problem.
    10. Switch the unit to the heating mode by moving the thermostat switch to heat. Fan should be set for AUTO.
    11. Check the refrigerant system pressures against the heating refrigerant pressure table in installation manual. Once again, if they do not match, check for airflow problems and then refrigeration system problems.
- NOTE:** If a charge problem is determined (high or low):
- A. Check for possible refrigerant leaks.
  - B. Recover all remaining refrigerant from unit and repair leak.
  - C. Evacuate unit down to 29" of vacuum.
  - D. Recharge the unit with refrigerant by weight. This is the only way to ensure a proper charge.

**FIGURE 7**  
Temperature and Pressure Measurement

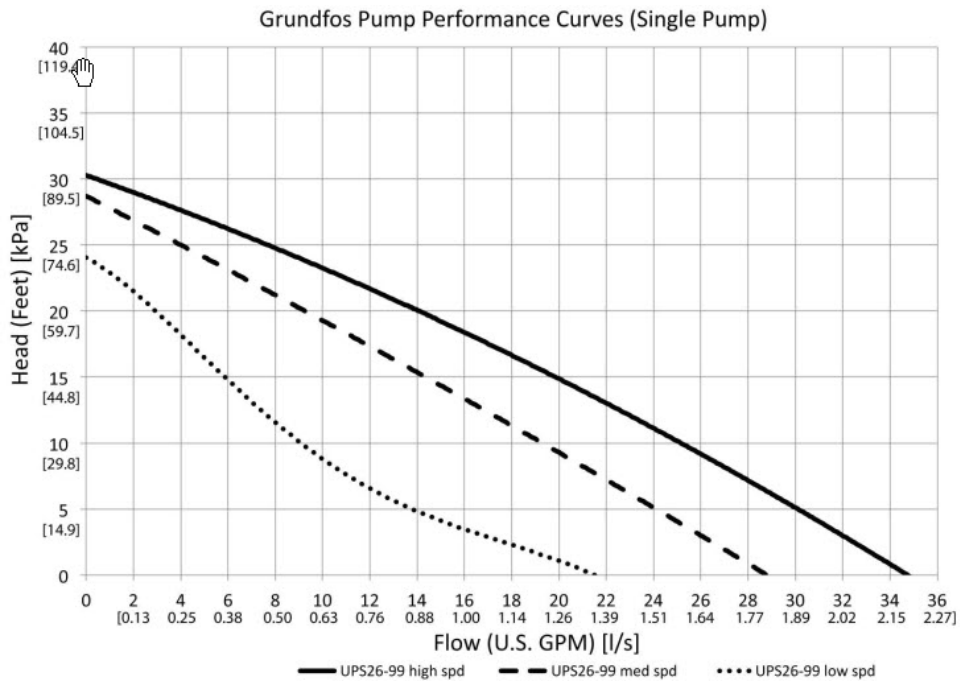


**FIGURE 8**  
Performance Model DORFC-1 Flow Center



Curves are manufacturer's reported averages using water at 68°F [20°C].

**FIGURE 9**  
Performance Model DORFC-2 Flow Center



Curves are manufacturer's reported averages using water at 68°F [20°C].

# GROUND WATER (WELL SYSTEM APPLICATIONS)

**NOTE:** *It is highly recommended on ground water systems (pump & dump) that a cupronickel coaxial coil is utilized on the source side of the system. Not doing so may void the product warranty due to aggressive/corrosive/highly oxygenated water attacking a copper coaxial water coil.*

**NOTE:** *Unit shipped from factory with 60 PSIG low pressure switch wired into control circuit for open loop applications.*

## WATER CONNECTIONS

It is very important that an adequate supply of clean, non-corrosive water at the proper pressure be provided before the installation is made. Insufficient water, in the heating mode for example, will cause the low pressure switch to trip, shutting down the heat pump. In assessing the capacity of the water system, it is advisable that the complete water system be evaluated to prevent possible lack of water or water pressure at various household fixtures whenever the heat pump turns on. All plumbing to and from the unit is to be installed in accordance with local plumbing codes. The use of plastic pipe, where permissible, is recommended to prevent electrolytic corrosion of the water pipe. Because of the relatively cold temperatures encountered with well water, it is strongly recommended that the water lines connecting the unit be insulated to prevent water droplets from condensing on the pipe surface.

Refer to piping shown in Figure 10 on page 20. Slow open/close with **End Switch (2)**, 24V, provides on/off control of the water flow to the unit. Refer to the wiring diagram for correct hookup of the valve solenoid coil.

**Constant Flow Valve (3)** provides correct flow of water to the unit regardless of variations in water pressure. Observe the water flow direction indicated by the arrow on the side of the valve body. Table 8A shows the allowable flow range for each model and Table 8B shows the constant flow valve part numbers.

**Strainer (8)** installed upstream of **water coil inlet** to collect foreign material which would clog the flow valve orifice.

Figure 10 shows the use of **shutoff valves (4)** and **(5)** on the in and out water lines to permit isolation of the unit from the plumbing system should future service work require this. Globe valves should not be used as shutoff valves because of the excessive pressure drop inherent in the valve design. Instead use gate or ball valves as shutoffs to minimize pressure drop.

**TABLE 8A**  
Minimum Required Flow Rates for  
Ground Water Installations

	GV27S3	GV38S3	GV51S3	GV61S3	GV71S3
Flow rate required GPM fresh water (Rated)	5 (7)	6 (9)	7 (12)	9 (15)	10 (16)

**TABLE 8B**  
Constant Flow Valves

Part No.	Min. Available Pressure PSIG	Flow Rate GPM
CFV-5	15*	5
CFV-6	15*	6
CFV-7	15*	7
CFV-9	15*	9
CFV-10	15*	10
CFV-11	15*	11
CFV-12	15*	12
CFV-15	15*	15
CFV-16	15*	16

\* The pressure drop through the constant flow valve will vary depending on the available pressure ahead of the valve. Unless minimum of 15 psig is available **immediately** ahead of the valve, no water will flow.

**Hose bib (6)** and **(7)** and tees should be included to permit acid cleaning the refrigerant-to-water coil should such cleaning be required. See **WATER CORROSION** on page 21.

**Hose bib (1)** provides access to the system to check water flow through the constant flow valve to insure adequate water flow through the unit. A water meter is used to check the water flow rate.

## WELL PUMP SIZING

Strictly speaking, sizing the well pump is the responsibility of the well drilling contractor. It is important, however, that the HVAC contractor be familiar with the factors that determine what size pump will be required. Rule of thumb estimates will invariably lead to under or oversized well pumps. Undersizing the pump will result in inadequate water to the whole plumbing system, but with especially bad results to the heat pump—NO HEAT/NO COOL calls

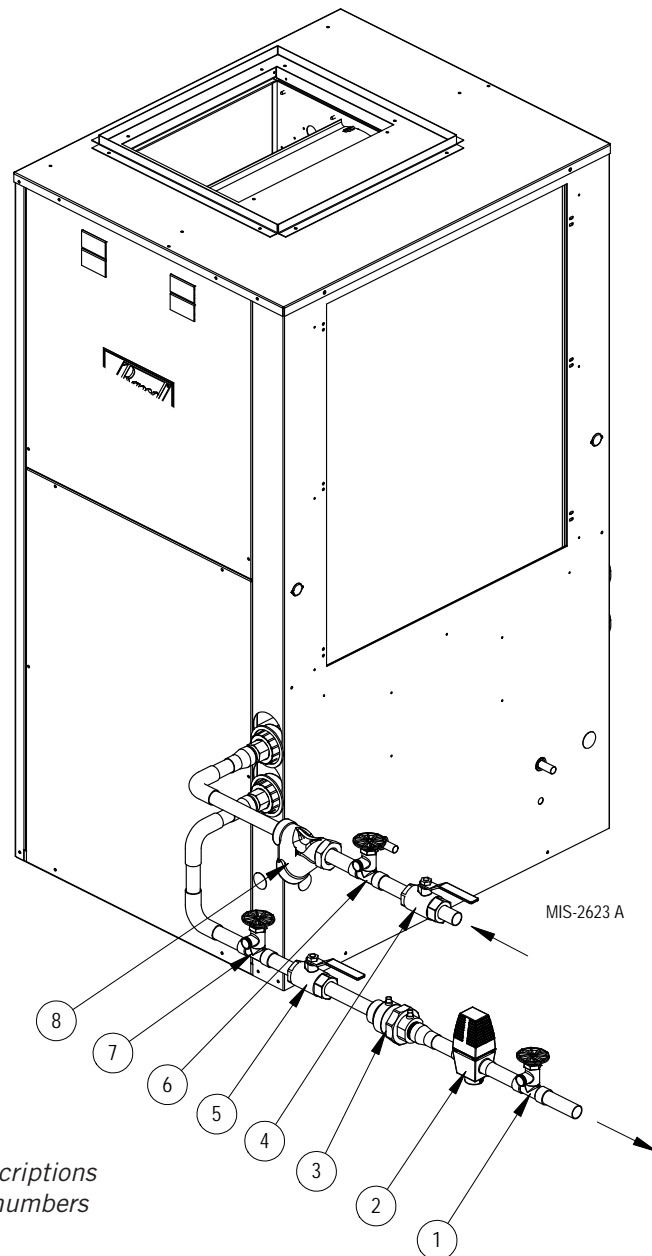
will result. Oversized pumps will short cycle and could cause premature pump motor or switch failures.

The well pump must be capable of supplying enough water and at an adequate pressure to meet competing demands of water fixtures. The well pump must be sized in such a way that three requirements are met:

1. Adequate flow rate in GPM.
2. Adequate pressure at the fixture.
3. Able to meet the above from the depth of the well-feet of lift.

The pressure requirements put on the pump are directly affected by the diameter of pipe being used, as well as, by the water flow rate through the pipe. The worksheet included should guarantee that the well pump has enough capacity. It should also ensure that the piping is not undersized, which would create too much pressure due to friction loss. High pressure losses due to undersized pipe will reduce efficiency and require larger pumps and could also create water noise problems.

**FIGURE 10**  
**Water Connection Components**



*See page 19 for descriptions  
for these reference numbers*

## START UP PROCEDURE FOR GROUND WATER SYSTEM

1. Be sure main power to the unit is OFF at disconnect.
2. Set thermostat system switch to OFF and fan switch to AUTO.
3. Move main power disconnect to ON. Except as required for safety while servicing, **DO NOT OPEN THE UNIT DISCONNECT SWITCH.**
4. Check system airflow for obstructions.
  - A. Move thermostat fan switch to ON. Blower runs.
  - B. Be sure all registers and grilles are open.
  - C. Move thermostat fan switch to AUTO. Blower should stop.
5. Fully open the manual inlet and outlet valves.
6. Check water flow:
  - A. Connect a water flow meter to the drain cock between the constant flow valve and the solenoid valve. Run a hose from the flow meter to a drain or sink. Open the drain cock.
  - B. Check the water flow rate through constant flow valve to be sure it is the same as the unit is rated for. (Example: 5 GPM for a GV27S3.)
  - C. When water flow is okay, close drain cock and remove the water flow meter. The unit is now ready to start.
7. Start the unit in cooling mode by moving thermostat switch to cool. Fan should be set for AUTO. Check to see the solenoid valve opened.
8. Check the system refrigerant pressures against the cooling refrigerant pressure table in the installation manual for rated water flow and entering water temperatures. If the refrigerant pressures do not match, check for airflow problem that refrigeration system problem.
9. Switch the unit to the heat mode by moving thermostat switch to heat. Fan should be set for AUTO. Check to see the solenoid valve opened again.
10. Check the refrigerant system pressures against the heating refrigerant pressure table in installation manual. Once again, if they do not match, check for airflow problems and then refrigeration system problems.

**NOTE:** If a charge problem is determined (high or low):

- A. Check for possible refrigerant loss.
- B. Discharge all remaining refrigerant from unit.
- C. Evacuate unit down to 29" of vacuum.
- D. Recharge the unit with refrigerant by weight. This is the only way to ensure proper charge.

## WATER CORROSION

Two concerns will immediately come to light when considering a water source heat pump, whether for ground water or for a ground loop application: Will there be enough water? And, how will the water quality affect the system?

Water quantity is an important consideration and one which is easily determined. The well driller must perform a pump down test on the well according to methods described by the National Well Water Association. This test, if performed correctly, will provide information on the rate of flow and on the capacity of the well. It is important to consider the overall capacity of the well when thinking about a water source heat pump because the heat pump may be required to run for extended periods of time.

The second concern, about water quality, is equally important. Generally speaking, if the water is not offensive for drinking purposes, it should pose no problem for the heat pump. The well driller or local water softening company can perform tests which will determine the chemical properties of the well water.

Water quality problems will show up in the heat pump in one or more of the following ways:

1. Decrease in water flow through the unit.
2. Decreased heat transfer of the water coil (entering to leaving water temperature difference is less).

There are four main water quality problems associated with ground water:

1. **Biological Growth.** This is the growth of microscopic organisms in the water and will show up as a slimy deposit throughout the water system. Shock treatment of the well is usually required and this is best left up to the well driller. The treatment consists of injecting chlorine into the well casing and flushing the system until all growth is removed.
2. **Suspended Particles in the Water.** Filtering will usually remove most suspended particles (fine sand, small gravel) from the water. The problem with suspended particles in the water is that it will erode metal parts, pumps, heat transfer coils, etc. So long as the filter is cleaned and periodically maintained, suspended particles should pose no serious problem. Consult with the well driller.
3. **Corrosion of Metal.** Corrosion of metal parts results from either highly corrosive water (acid water, generally not the case with ground water) or galvanic reaction between dissimilar metals in the presence of water. By using plastic plumbing or dielectric unions, galvanic reaction is eliminated. The use of corrosion resistant materials such as the Cupronickel coil through the water system will reduce corrosion problems significantly.

4. **Scale Formation.** Of all the water problems, the formation of scale by ground water is by far the most common. Usually this scale is due to the formation of calcium carbonate but magnesium carbonate or calcium sulfate may also be present. Carbon dioxide gas (CO<sub>2</sub>), the carbonate of calcium and magnesium carbonate, is very soluble in water. It will remain dissolved in the water until some outside factor upsets the balance. This outside influence may be a large change in water temperature or pressure. When this happens, enough carbon dioxide gas combines with dissolved calcium or magnesium in the water and falls out of solution until a new balance is reached. The change in temperature that this heat pump produces is usually not high enough to cause the dissolved gas to fall out of solution. Likewise, if pressure drops are kept to a reasonable level, no precipitation of carbon dioxide should occur.

## REMEDIES OF WATER PROBLEMS

### Water Treatment

Water treatment can usually be economically justified for water loop systems. However, because of the large amounts of water involved with a ground water system, water treatment is generally too expensive.

### Acid Cleaning the Water Coil or Heat Pump Recovery Unit

If scaling of the coil is strongly suspected, the coil can be cleaned up with a solution of phosphoric acid (food grade acid). Follow the manufacturer's directions for mixing, use, etc. The acid solution can be introduced into the heat pump coil through hose bib A (see Figure 11). Be sure the isolation valves are closed to prevent contamination of the rest of the system by the coil. The acid should be pumped from a bucket into the hose bib and returned to the bucket through the other hose bib B. Follow the manufacturer's directions for the product used as to how long the solution is to be circulated, but it is usually circulated for a period of several hours.

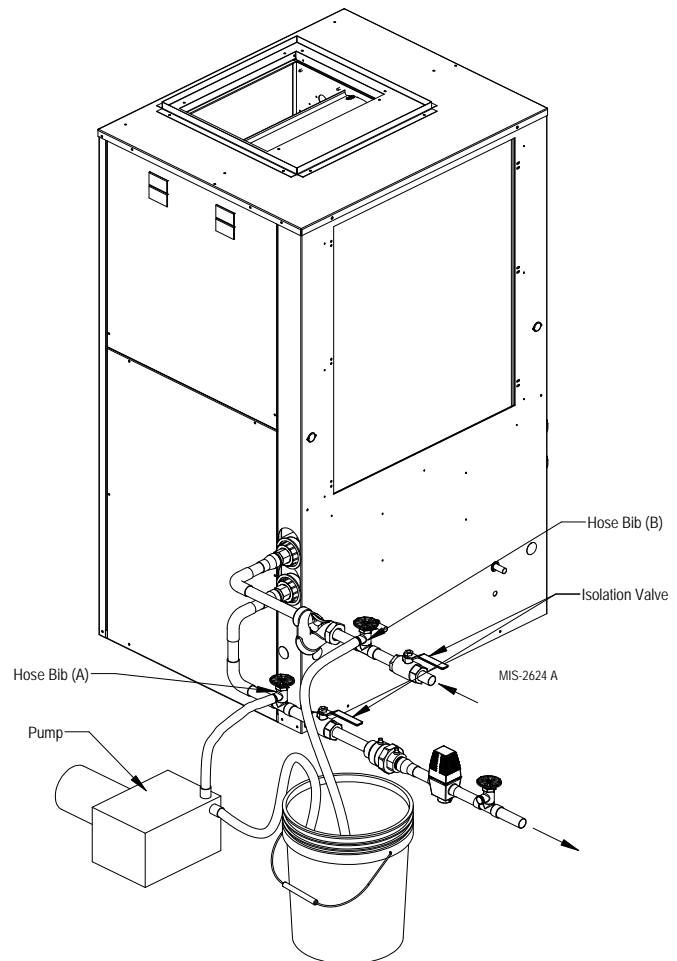
## LAKE AND POND INSTALLATIONS

Lakes and ponds can provide a low cost source of water for heating and cooling with a ground water heat pump. Direct usage of the water without some filtration is not recommended as algae and turbid water can foul the water to refrigerant heat exchanger. Instead, there have been very good results using a dry well dug next to the water line or edge. Normal procedure in installing a dry well is to backhoe a 15' to 20' hole adjacent to the body of water (set backhoe as close to the water's edge as possible). Once excavated, a perforated plastic casing should be installed with gravel backfill placed around the casing. The gravel bed should provide adequate filtration of the water to allow good performance of the ground water heat pump.

The following is a list of recommendations to follow when installing this type of system:


- A. A lake or pond should be at least 1 acre (40,000 square feet) in surface area for each 50,000 BTUs of ground water heat pump capacity or have two times the cubic feet size of the dwelling to be heated (includes basement if heated).
- B. The average water depth should be at least 4' and there should be an area where the water depth is at least 12' to 15' deep.

**FIGURE 11**  
**Cleaning Water Coil**



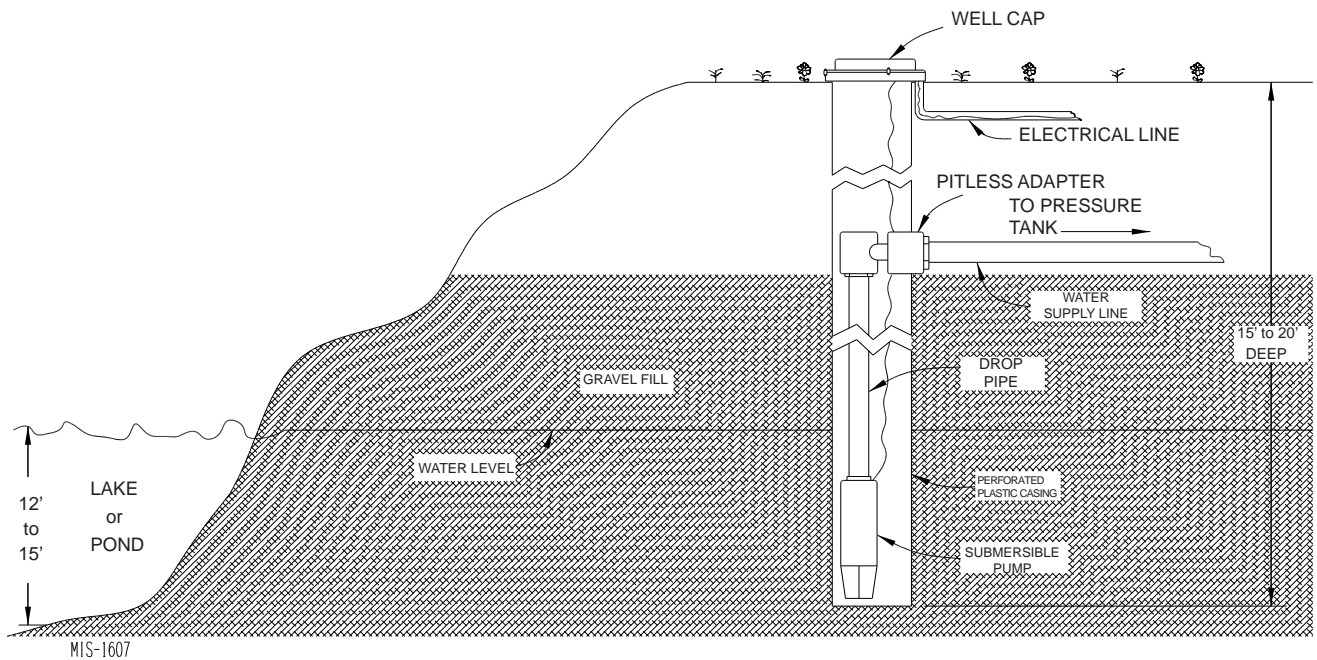
- C. If possible, use a submersible pump suspended in the dry well casing. Jet pumps and other types of suction pumps normally consume more electrical energy than similarly sized submersible pumps. Pipe the unit the same as a water well system.
- D. Size the pump to provide necessary GPM for the ground water heat pump. A 12 GPM or greater water flow rate is required on all models when used on this type system.

- E. A pressure tank should be installed in dwelling to be heated adjacent to the ground water heat pump. A pressure switch should be installed at the tank for pump control.
- F. All plumbing should be carefully sized to compensate for friction losses, etc., particularly if the pond or lake is over 200' from the dwelling to be heated or cooled.
- G. Keep all water lines below low water level and below the frost line.
- H. Most installers use 4" field tile (rigid plastic or corrugated) for water return to the lake or pond.
- I. The drain line discharge should be located at least 100' from the dry well location.
- J. The drain line should be installed with a slope of 2" per 10' of run to provide complete drainage of the line when the ground water heat pump is not operating. This gradient should also help prevent freezing of the discharge where the pipe terminates above the frost line.
- K. Locate the discharge high enough above high water level so the water will not back up and freeze inside the drain pipe.
- L. Where the local conditions prevent the use of a gravity drainage system to a lake or pond, run standard plastic piping out into the pond below the frost and low water level.

	<h1 style="margin: 0;">WARNING</h1>
<p>Thin ice may result in the vicinity of the discharge line.</p>	

For complete information on water well systems and lake and pond applications, refer to manual from the distributor.

**FIGURE 12**  
**Lake and Pond Installation**



# SEQUENCE OF OPERATION

---

## BLOWER

Blower functions are all automatic through the thermostat control. (See Table 1 for the specific airflows on each speed.) Motor control inputs are all 24 VAC with line power to motor being continuous.

On a call for “G” from the thermostat (*call for manual fan*), speed tap #1 on the blower motor is energized.

On a call for “Y1” from the thermostat (heating or cooling), speed tap #2 of the blower motor is energized immediately. Simultaneously, the “Y1” tap of the blower control board is also energized, and following 5 minutes, the blower control will power speed tap #3 of the blower motor.

On a call for “Y2” operation from the thermostat (heating or cooling), speed tap #5 will be energized through the blower control board. *The exception is a jumper pin connection on the blower control board. It comes from the factory by default jumpering pins #4 and #5 together to run the blower at nominal rated full load airflow. If this is too noisy, this jumper can be removed from pins #4/#5 to allow the full load airflow to be reduced by 10% (see unit wiring diagram).*

On any call for “W” (electric heat operation) from the thermostat, speed tap #5 is always energized. (It is not affected by the #4/#5 jumper on the blower control board.)

## PART LOAD COOLING

When thermostat system switch is placed in COOL, it completes a circuit from “R” to “O”, energizing the reversing valve solenoid. On a call for cooling, the thermostat completes a circuit from “R” to “Y1”, which energizes the compressor contactor and blower motor on speed tap #2 initially, then speed tap #3 after 5 minutes (see **BLOWER** above).

## FULL LOAD COOLING

The system should already be in part load cooling operation prior to full load cooling being energized. Additionally, the thermostat completes a circuit from “R” to “Y2”. This sends a signal to both the staging solenoid on the side of the compressor and energizes either tap #5 or tap #4 of the blower motor (see **BLOWER** above).

## PART LOAD HEATING (No Electric Heat)

When thermostat system switch is placed in HEAT, the reversing valve solenoid is no longer energized. On a call for part load heating, the thermostat completes a circuit from “R” to “Y1”, which energizes the compressor contactor and blower motor on speed tap #2 initially, then speed tap #3 after 5 minutes (see **BLOWER** above).

## FULL LOAD HEATING (No Electric Heat)

The system should already be in part load heating operation prior to full load heating being energized. Additionally, the thermostat completes a circuit from “R” to “Y2”. This sends a signal to both the staging solenoid on the side of the compressor and energizes either tap #5 or tap #4 of the blower motor (see **BLOWER** above).

## SUPPLEMENTARY ELECTRIC HEAT

The system should already be in full load heating operation (above). The thermostat completes a circuit from “R” to “W2”, which energizes up to 9 KW of electric heat (depending on heater package installed). 9 KW of electric heat is the limit when operating with the heat pump and is controlled through the emergency heat relay.

## EMERGENCY HEAT MODE

When thermostat system switch is placed in EMERGENCY HEAT MODE and the thermostat calls for heat, it completes a circuit from “R” to “E” and from “R” to “W2”. This will energize the heater package for all available KW per the installed heater package. (*The call from “R” to “E” locks out compressor operation.*) The blower motor is automatically energized with this function and will run on speed #5 (see **BLOWER** above).

## GEOTHERMAL LOGIC CONTROL

If the controller operates in normal mode, the green Status LED blinks. This indicates that 24 volt power is applied to the board and the controller is running in normal operation.

On initial power up and call for compressor operation, a 5-minute delay + a random start delay of 0 to 60-second is applied. After the random delay, the compressor relay is energized (terminals CC and CCG). When the “Y” input opens, the compressor de-energizes.

**NOTE:** *The time delay + random start can be disabled by removing the Test jumper on the Geothermal Logic Control Board. However, this is NOT recommended. This is only intended to be a function for factory run-in processes.*

Water Solenoid – When “Y” signal is sent to Geothermal Logic Control, the water solenoid output “A” terminal will energize 10 seconds prior to “CC” output that starts compressor.

**NOTE:** *The 10-second time delay between the energization of the “A” terminal and the “CC” terminal can be disabled by removing the WSD jumper on the Geothermal Logic Control Board.*



Anti-Short Cycle Timer – After compressor shutdown or power disruption, a 5-minute timer is applied and prevents the compressor from operating.

## HIGH PRESSURE SWITCH

(Terminals HP1 and HP2) Circuit will be proved as “closed” prior to energizing “A” or “CC” terminals. If pressure switch opens, compressor will go into soft lockout mode and compressor operation will be terminated; green fault light illuminated. Logic control will then go through 5-minute delay on break + random start sequence. If no fault found on next run cycle, compressor will continue operation. If fault reoccurs, hard lockout occurs, and fault signal is sent to “L” terminal.

## LOW PRESSURE SWITCH

(Terminals LP1 and LP2) Circuit will be proved as “closed” prior to energizing “A” or “CC” terminals. The conditions of the LP terminals will then be ignored for the first 90 seconds after a demand for compressor operation. Following this 90-second period, if pressure switch opens, compressor will go into soft lockout mode and compressor operation will be terminated; orange fault light illuminated. The control board will then go through a 5-minute delay on break + random start sequence. If no fault found on next run cycle, compressor will continue operation. If fault reoccurs, hard lockout occurs, and fault signal is sent to “L” terminal.

## FLOW SWITCH

(Terminals FS and FS2) Circuit will be proved as “closed” prior to energizing “CC” terminal. If flow switch opens, compressor will go into soft lockout mode and compressor operation will be terminated; red fault light illuminated. Logic control will then go through 5-minute delay on break + random start sequence. If no fault found on next run cycle, compressor will continue operation. If fault reoccurs, hard lockout occurs and fault signal is sent to “L” terminal.

**NOTE:** Jumper wire is factory installed.

## EVAPORATOR CONDENSATE OVERFLOW

(Terminals CO and CO<sub>2</sub>) This input operates when the water level in the evaporator pan rises and completes a signal across the terminals of the terminal block located in the indoor coil drain pan; yellow fault light illuminates. If fault clears, the logic control will go through 5-minute delay + random start. If fault reoccurs, or didn't clear the first time after 30 seconds, the control will go into hard lockout, and will energize the “L” output signal.

## UNDER AND OVER VOLTAGE PROTECTION

When an under or over voltage condition exists, the controller locks out the unit. When condition clears, the controller automatically releases the unit to normal operation and the compressor restarts after the random start and anti-short cycle timings are met. The under and

over voltage protection starts at plus or minus 20% from nominal voltage and returns to operation at plus or minus 10% from nominal voltage. All four (4) LED fault lights will flash when an under or over voltage condition occurs.

**NOTE:** The over voltage protection can be disabled by removing the O/V jumper on the Geothermal Logic Control Board.

## INTELLIGENT RESET

The Geothermal Logic Control has an intelligent reset feature after a safety control is activated. The controller locks out the unit for 5 minutes; at the end of this period, the controller checks to verify that all faults have been cleared. If faults have been cleared, the controller restarts the unit. If a second fault occurs, the controller will lock out the unit until the unit is manually reset by breaking “Y” signal from thermostat. The last fault will be kept in memory after a full lockout; this is only cleared by cycling the power.

## ALARM OUTPUT

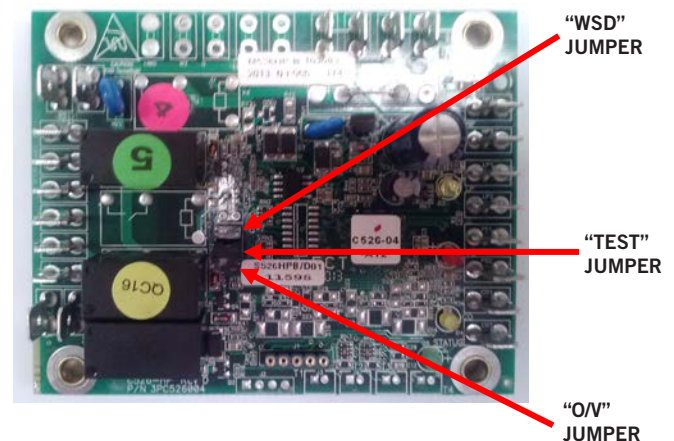
The “L” terminal has 24 volts applied when a hard lockout occurs. This can be used to drive a fault light or a low voltage relay.

## PRESSURE SERVICE PORTS

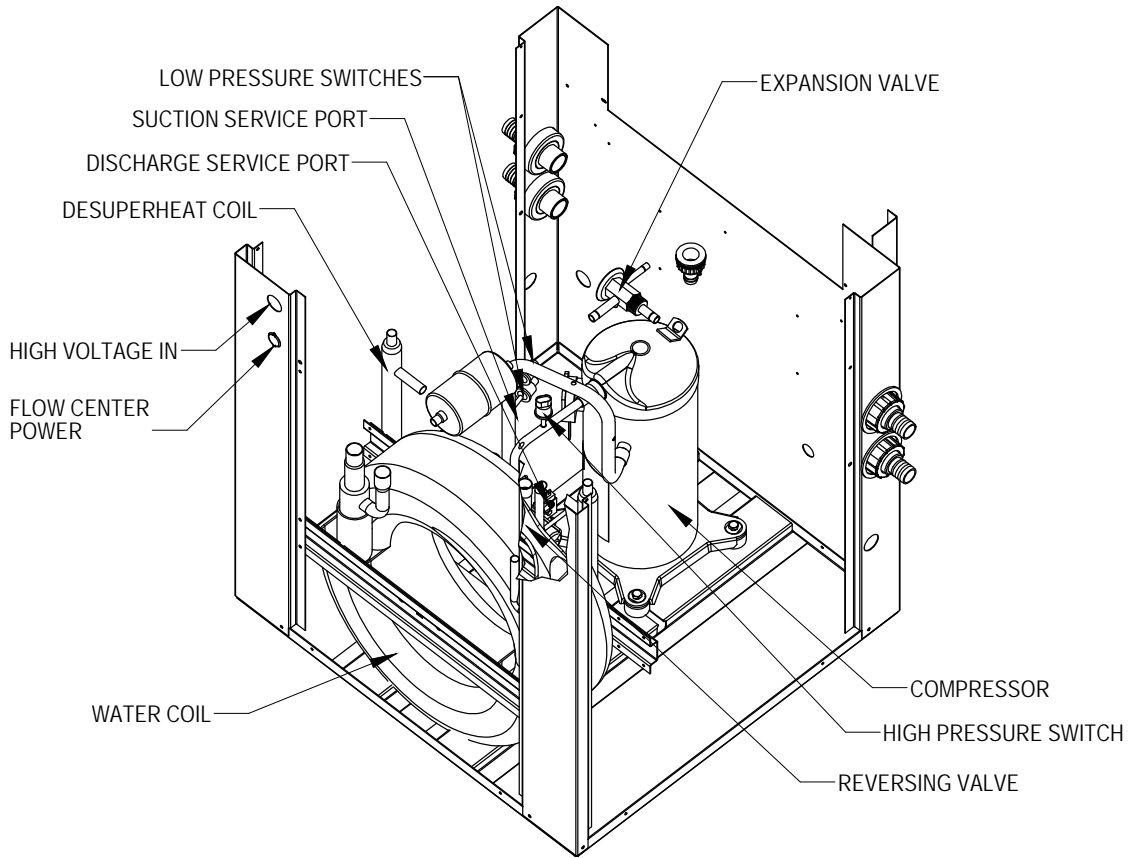
High and low pressure service ports are installed on all units so that the system operating pressures can be observed. Pressure tables can be found later in the manual covering all models. It is imperative to match the correct pressure table to the unit by model number.

## SYSTEM START UP

- Step 1 – Close disconnect switch(es) and set the thermostat to cool and the temperature to the highest setting.
- Step 2 – Check for proper airflow across the indoor coil.
- Step 3 – Connect the service gauges and allow the unit to run for at least 10 minutes or until pressures are stable. Check pressures to the system pressure table attached to the unit service panel.
- Step 4 – Fill out Ground Source Heat Pump Performance Report.

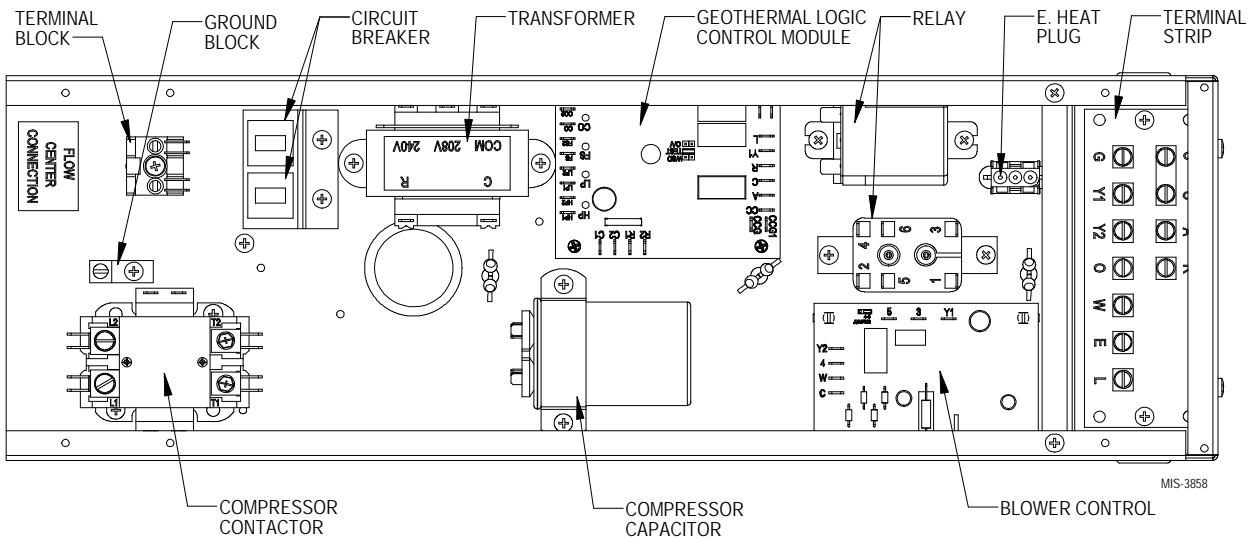


**FIGURE 13**  
**Component Location**



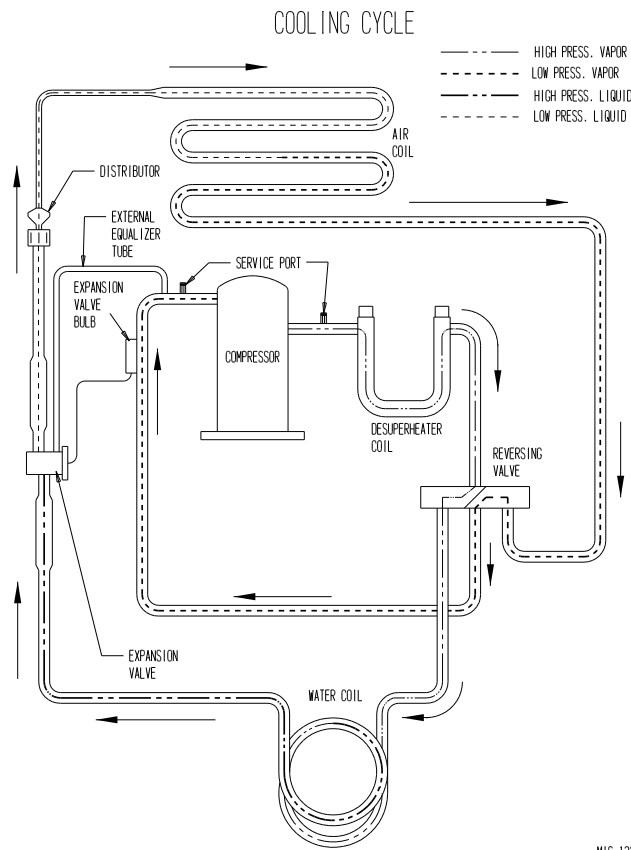
MIS-2625

**FIGURE 14**  
**Control Panel**

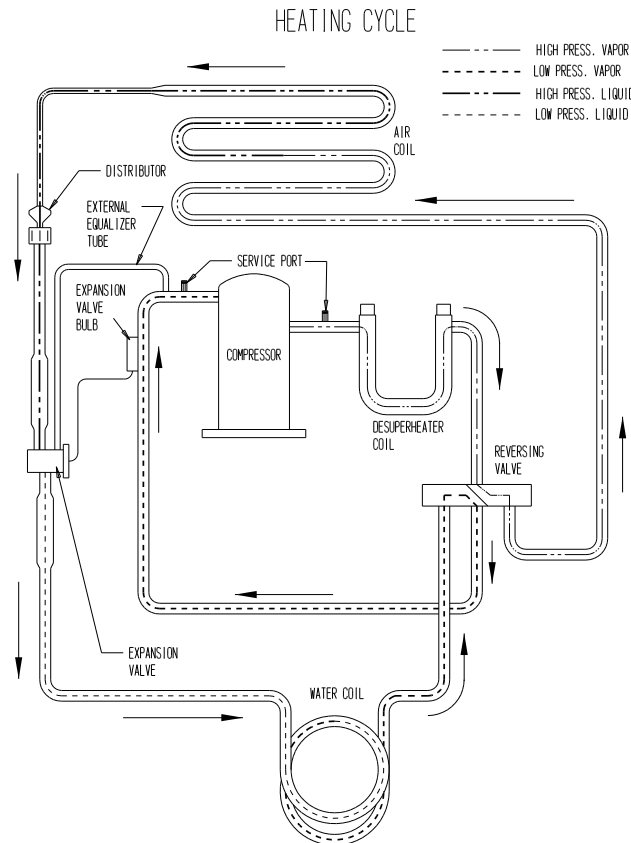


MIS-3858

**FIGURE 15**  
**Refrigerant Flow Diagrams**



MIS-1229



MIS-1228

**FIGURE 16A Pressure Tables**

Model	Return Air Temperature	Pressure	FULL LOAD COOLING — Fluid Temperature Entering Water Coil °F																
			30°F	35°F	40°F	45°F	50°F	55°F	60°F	65°F	70°F	75°F	80°F	85°F	90°F	95°F	100°F	105°F	110°F
GV27S3	75° DB	Low Side	111	115	118	121	124	128	131	134	137	138	139	140	141	142	143	144	145
	62° WB	High Side	135	150	165	180	195	210	224	239	254	275	296	317	338	358	379	400	421
	80° DB	Low Side	119	123	126	130	133	137	140	144	147	148	149	150	151	152	153	154	155
	67° WB	High Side	138	153	169	184	200	215	230	246	261	282	304	325	346	368	389	410	432
GV38S3	85° DB	Low Side	128	132	135	139	143	147	151	154	158	159	160	161	162	163	164	166	167
	72° WB	High Side	143	159	175	191	206	222	238	254	270	292	314	336	358	381	403	425	447
	75° DB	Low Side	101	104	108	111	115	118	121	125	128	129	131	132	134	135	137	138	139
	62° WB	High Side	145	160	175	189	204	218	233	248	262	283	304	324	345	365	386	407	427
GV38S3	80° DB	Low Side	108	112	115	119	123	126	130	133	137	139	140	142	143	145	146	148	149
	67° WB	High Side	149	164	179	194	209	224	239	254	269	290	311	333	354	375	396	417	438
	85° DB	Low Side	116	120	124	128	132	136	139	143	147	149	151	152	154	155	157	159	160
	72° WB	High Side	154	170	185	201	216	232	247	263	278	300	322	344	366	388	410	432	454

Model	Return Air Temperature	Pressure	FULL LOAD HEATING — Fluid Temperature Entering Water Coil °F																
			5°F	10°F	15°F	20°F	25°F	30°F	35°F	40°F	45°F	50°F	55°F	60°F	65°F	70°F	75°F	80°F	85°F
GV27S3	70° DB	Low Side	--	49	58	66	75	83	92	100	109	117	125	134	142	150	158	167	175
		High Side		265	274	282	291	299	308	316	325	333	343	353	363	373	383	393	403
GV38S3	70° DB	Low Side	52	58	64	70	75	81	87	93	98	104	112	121	129	137	145	154	162
		High Side	215	228	241	255	268	281	294	308	321	334	343	352	361	370	379	388	397

Model	Return Air Temperature	Pressure	PART LOAD COOLING — Fluid Temperature Entering Water Coil °F																
			30°F	35°F	40°F	45°F	50°F	55°F	60°F	65°F	70°F	75°F	80°F	85°F	90°F	95°F	100°F	105°F	110°F
GV27S3	75° DB	Low Side	104	109	113	118	123	128	133	137	142	143	144	145	146	147	148	149	150
	62° WB	High Side	114	130	146	161	177	193	208	224	240	260	280	301	321	341	362	382	402
	80° DB	Low Side	111	116	121	126	132	137	142	147	152	153	154	155	156	157	158	159	160
	67° WB	High Side	117	133	149	165	182	198	214	230	246	267	288	309	329	350	371	392	413
GV38S3	85° DB	Low Side	119	125	130	136	141	147	152	158	163	164	166	167	168	169	170	171	172
	72° WB	High Side	121	138	154	171	188	205	221	238	255	276	298	319	341	362	384	406	427
	75° DB	Low Side	104	108	112	116	120	124	128	132	137	138	139	140	141	143	144	145	146
	62° WB	High Side	126	140	155	169	184	198	213	227	242	262	282	302	322	343	363	383	403
GV38S3	80° DB	Low Side	111	115	120	124	129	133	137	142	146	147	149	151	153	154	155	157	158
	67° WB	High Side	129	144	159	174	189	203	218	233	248	269	289	310	331	351	372	393	413
	85° DB	Low Side	119	124	129	133	138	143	148	152	157	158	160	161	163	164	166	167	168
	72° WB	High Side	134	149	164	180	195	210	226	241	257	278	299	321	342	364	385	406	428

**FIGURE 16B Pressure Tables**

Model	Return Air Temp.	Pressure	FULL LOAD COOLING — Fluid Temperature Entering Water Coil °F																
			30°F	35°F	40°F	45°F	50°F	55°F	60°F	65°F	70°F	75°F	80°F	85°F	90°F	95°F	100°F	105°F	110°F
GV51S3	75° DB 62° WB	Low Side High Side	104 141	106 157	109 173	112 189	115 205	117 221	120 236	123 252	125 268	127 289	128 309	129 330	130 351	132 371	133 392	134 413	135 433
	80° DB 67° WB	Low Side High Side	111 145	114 161	117 178	120 194	123 210	125 226	128 243	131 259	134 275	135 296	137 317	138 339	139 360	141 381	142 402	143 423	145 444
	85° DB 72° WB	Low Side High Side	119 150	122 167	126 184	129 201	132 217	135 234	138 251	141 268	144 285	145 307	147 328	148 350	150 372	151 394	153 416	154 438	156 460
GV61S3	75° DB 62° WB	Low Side High Side	108 143	110 160	112 176	114 192	116 208	118 224	120 241	122 257	123 273	125 293	126 314	127 334	128 354	130 375	131 395	132 415	133 436
	80° DB 67° WB	Low Side High Side	116 147	118 164	120 180	122 197	124 214	126 230	128 247	130 263	132 280	133 301	135 322	136 343	137 363	139 384	140 405	141 426	143 447
	85° DB 72° WB	Low Side High Side	125 152	127 169	129 187	131 204	133 221	135 238	138 255	140 273	142 290	143 311	145 333	146 354	148 376	149 398	151 419	152 441	153 462
GV71S3	75° DB 62° WB	Low Side High Side	110 175	111 186	112 197	113 209	115 220	116 231	117 243	118 254	119 265	119 286	119 307	120 328	120 348	120 369	121 390	121 411	121 432
	80° DB 67° WB	Low Side High Side	118 179	119 191	120 202	121 214	123 226	124 237	125 249	126 260	127 272	127 293	128 315	128 336	128 357	129 379	129 400	129 421	130 443
	85° DB 72° WB	Low Side High Side	127 185	128 197	129 209	130 221	132 233	133 245	134 257	135 269	137 282	137 304	137 326	138 348	138 370	138 392	139 414	139 436	139 458
Model	Return Air Temp.	Pressure	FULL LOAD HEATING — Fluid Temperature Entering Water Coil °F																
			5°F	10°F	15°F	20°F	25°F	30°F	35°F	40°F	45°F	50°F	55°F	60°F	65°F	70°F	75°F	80°F	85°F
GV51S3	70° DB	Low Side High Side	-- --	-- --	50 291	58 300	65 308	73 317	81 326	89 335	96 343	104 352	113 363	123 374	132 385	141 396	150 407	160 418	169 429
GV61S3	70° DB	Low Side High Side	-- --	45 283	53 294	61 305	69 315	77 326	85 337	93 348	101 358	109 369	118 382	127 395	136 408	145 421	154 434	163 447	172 460
GV71S3	70° DB	Low Side High Side	-- --	45 268	52 278	59 287	66 297	73 306	80 316	87 325	94 335	101 344	111 355	121 366	131 376	141 387	151 398	161 409	171 419

Model	Return Air Temp.	Pressure	PART LOAD COOLING — Fluid Temperature Entering Water Coil °F																
			30°F	35°F	40°F	45°F	50°F	55°F	60°F	65°F	70°F	75°F	80°F	85°F	90°F	95°F	100°F	105°F	110°F
GV51S3	75° DB 62° WB	Low Side High Side	106 127	109 142	112 157	115 172	119 187	122 202	125 217	129 233	132 248	133 268	135 288	136 308	137 328	139 348	140 369	142 389	143 409
	80° DB 67° WB	Low Side High Side	113 130	117 146	120 161	124 177	127 192	131 208	134 223	138 239	141 254	143 275	144 295	146 316	147 337	149 357	150 378	152 399	153 419
	85° DB 72° WB	Low Side High Side	121 135	125 151	129 167	133 183	137 199	140 215	144 231	148 247	152 263	153 284	155 306	156 327	158 348	160 370	161 391	163 413	164 434
GV61S3	75° DB 62° WB	Low Side High Side	108 136	111 150	114 165	117 179	120 194	123 209	126 223	129 238	132 253	133 273	134 293	135 312	136 332	137 352	138 372	139 392	141 412
	80° DB 67° WB	Low Side High Side	115 139	118 154	122 169	125 184	128 199	131 214	135 229	138 244	141 259	142 280	143 300	145 321	146 341	147 362	148 382	149 403	150 423
	85° DB 72° WB	Low Side High Side	124 144	127 159	131 175	134 190	138 206	141 221	145 237	148 253	152 268	153 289	154 311	155 332	157 353	158 374	159 395	160 417	162 438
GV71S3	75° DB 62° WB	Low Side High Side	108 139	111 153	113 167	115 181	117 195	119 209	121 223	123 237	125 251	127 271	128 291	129 312	130 332	132 352	133 372	134 393	135 413
	80° DB 67° WB	Low Side High Side	116 143	118 157	121 172	123 186	125 200	127 214	130 229	132 243	134 257	135 278	137 299	138 320	139 340	141 361	142 382	143 403	145 424
	85° DB 72° WB	Low Side High Side	125 148	127 163	130 178	132 192	134 207	137 222	139 236	142 251	144 266	145 288	147 309	148 331	150 352	151 374	153 395	154 417	156 438
Model	Return Air Temp.	Pressure	PART LOAD HEATING — Fluid Temperature Entering Water Coil °F																
			5°F	10°F	15°F	20°F	25°F	30°F	35°F	40°F	45°F	50°F	55°F	60°F	65°F	70°F	75°F	80°F	85°F
GV51S3	70° DB	Low Side High Side	-- --	49 264	57 273	65 281	73 290	81 298	89 307	97 315	105 324	113 332	123 342	132 351	142 361	151 370	161 380	170 389	180 399
GV61S3	70° DB	Low Side High Side	-- --	49 261	58 271	66 281	75 291	83 301	92 311	100 321	109 331	117 341	126 351	135 362	144 372	153 382	162 392	171 403	180 413
GV71S3	70° DB	Low Side High Side	-- --	47 258	55 267	64 277	72 286	80 295	88 304	97 314	105 323	113 332	123 341	132 351	142 360	151 369	161 378	170 388	180 397

LOW SIDE PRESSURE +/- 2 PSIG HIGH SIDE PRESSURE +/- 5 PSIG

Tables based upon rated CFM (airflow) across the evaporator coil.

If incorrect charge suspected (more than ±2 psig suction, ±5 psig liquid), it is recommended refrigerant charge be reclaimed, system evacuated and charged to serial plate quantity.



## SERVICE HINTS

1. Caution owner to maintain clean air filters at all times and to not needlessly close off supply and return air registers. This reduces airflow through the system, which shortens equipment service life as well as increasing operating costs.
2. Check all power fuses or circuit breakers to be sure that they are the correct rating.

## UNBRAZING SYSTEM COMPONENTS

If the refrigerant charge is removed from a scroll equipped unit by bleeding the high side only, it is sometimes possible for the scrolls to seal, preventing pressure equalization through the compressor. This may leave low side shell and suction line tubing pressurized. If the brazing torch is then applied to the low side while the low side shell and suction line contains pressure, the pressurized refrigerant and oil mixture could ignite when it escapes and contacts the brazing flame. To prevent this occurrence, it is important to check both the high and low side with manifold gauges before unbrazing.

This unit is equipped with an ECM motor. It is important that the blower motor plugs are not plugged in or unplugged while the power is on. Failure to remove power prior to unplugging or plugging in the motor could result in motor failure.



## WARNING

Both the high and low side of the scroll compressor must be checked with manifold gauges before unbrazing system components. Failure to do so could cause pressurized refrigerant and oil mixture to ignite if it escapes and contacts the brazing flame causing property damage, bodily harm or death.



## CAUTION

Do not plug in or unplug blower motor connectors while the power is on. Failure to do so may result in motor failure.

## COMPRESSOR SOLENOID

(See **Sequence of Operation** on pages 24 and 25 for function.) A nominal 24-volt direct current coil activates the internal compressor solenoid. The input control circuit voltage must be 18 to 28 volt ac. The coil power requirement is 20 VA. The external electrical connection is made with a molded plug assembly. This plug contains a full wave rectifier to supply direct current to the unloader coil.

**Compressor Solenoid Test Procedure** – If it is suspected that the unloader is not working, the following methods may be used to verify operation.

1. Operate the system and measure compressor amperage. Cycle the compressor solenoid on and off at 10-second intervals. The compressor amperage should go up or down at least 25%.
2. If Step 1 does not give the expected results, shut unit off. Apply 18 to 28 volt ac to the solenoid molded plug leads and listen for a click as the solenoid pulls in. Remove power and listen for another click as the solenoid returns to its original position.
3. If clicks can't be heard, shut off power, remove the control circuit molded plug from the compressor and measure the solenoid coil resistance (see Table 9).

**TABLE 9**  
**Solenoid Coil Resistance**

Compressor Model	Solenoid Ohms
ZPS***K4	33.6 Ω
ZPS***K5	350 Ω or 1640 Ω
ZPS***K6	1640 Ω

4. Next, check the molded plug.

**Voltage check:** Apply control voltage to the plug wires (18 to 28 volt ac). The measured **dc** voltage at the female connectors in the plug should be around 15 to 27 vdc.

**Resistance check:** Measure the resistance from the end of one molded plug lead to either of the two female connectors in the plug. One of the connectors should read close to 0 ohms, while the other should read infinity. Repeat with other wire. The same female connector as before should read zero, while the other connector again reads infinity. Reverse polarity on the ohmmeter leads and repeat. The female connector that read infinity previously should now read close to 0 ohms.

Replace plug if either of these test methods does not show the desired results.

## TROUBLESHOOTING GE ENDURA PRO SERIES ECM MOTORS

### If the Motor Is Running

1. It is normal for the motor to rock back and forth on start up. Do not replace the motor if this is the only problem identified.
2. If the system is excessively noisy, does not appear to change speeds in response to a demand (Heat, Cool, Other) or is having symptoms during the cycle such as tripping limit or freezing coil, check the following:
  - A. Wait for programmed delays to time out.
  - B. Ensure that the motors control inputs are wired as shown in the factory-supplied wiring diagram to ensure motor is getting proper control signals and sequencing.
  - C. Remove the filter and check that all dampers, registers and grilles are open and free flowing. If removing the filters corrects the problem, clean or replace with a less restrictive filter. Also check and clean the blower wheel or coil as necessary.
  - D. Check the external static pressure (total of both supply and return) to ensure it is within

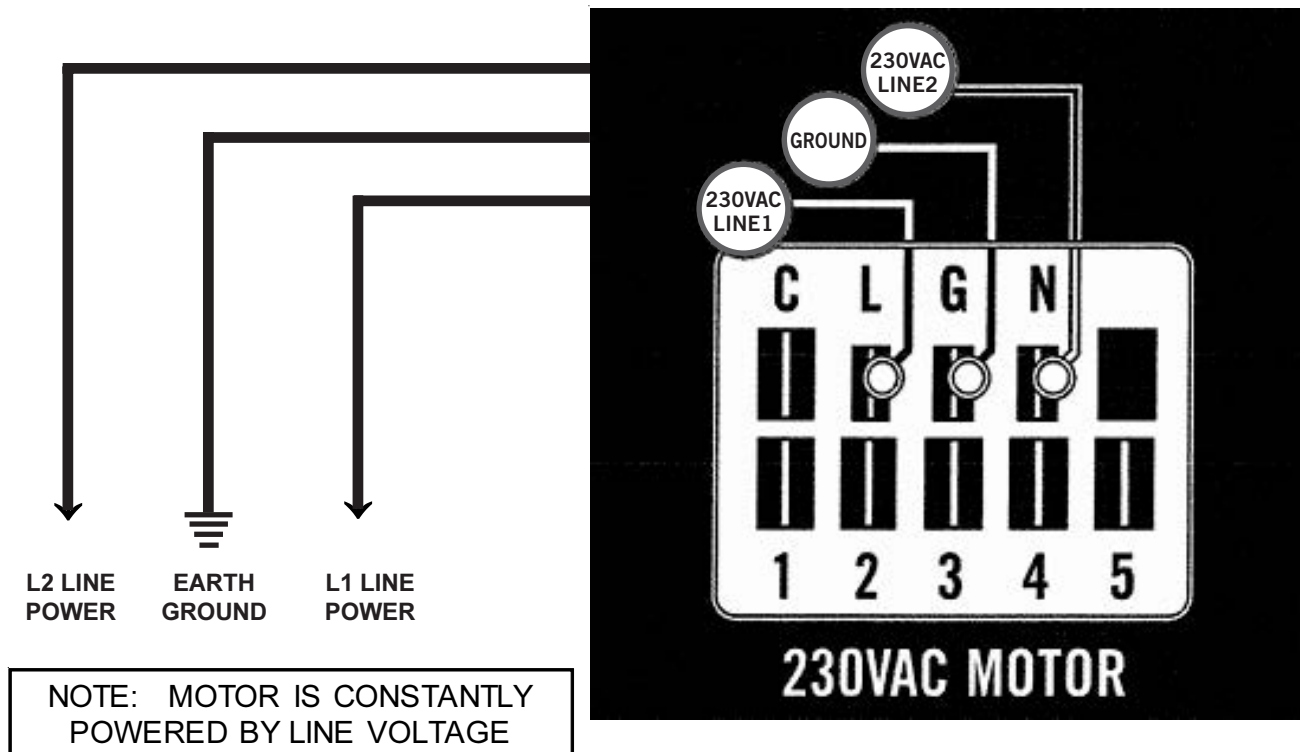
the range as listed on the unit serial plate. If higher than allowed, additional duct work is needed.

- E. If the motor does not shut off at the end of the cycle, wait for any programmed delays to time out (no more than 90 seconds). Also make sure that there is no call for "Continuous Fan" on the "G" terminal.
- F. If the above diagnostics do not solve the problem, confirm the voltage checks in the next section below, then continue with the "Model Endura Pro Communication Diagnostics".

### If the Motor Is Not Running

1. Check for proper high voltage and ground at the (L/L1) (G) (N/L2) connections at the motor (see Figure 17). Correct any voltage issues before proceeding to the next step. The Endura Pro motor is voltage specific. Only the correct voltage should be applied to the proper motor. Input voltage within plus or minus 10% of the nominal 230 VAC is acceptable.
2. If the motor has proper high voltage and ground at the (L/L1) (G) (N/L2) connections, then continue with the "Model Endura Pro Communication Diagnostics".

FIGURE 17  
Motor Connections





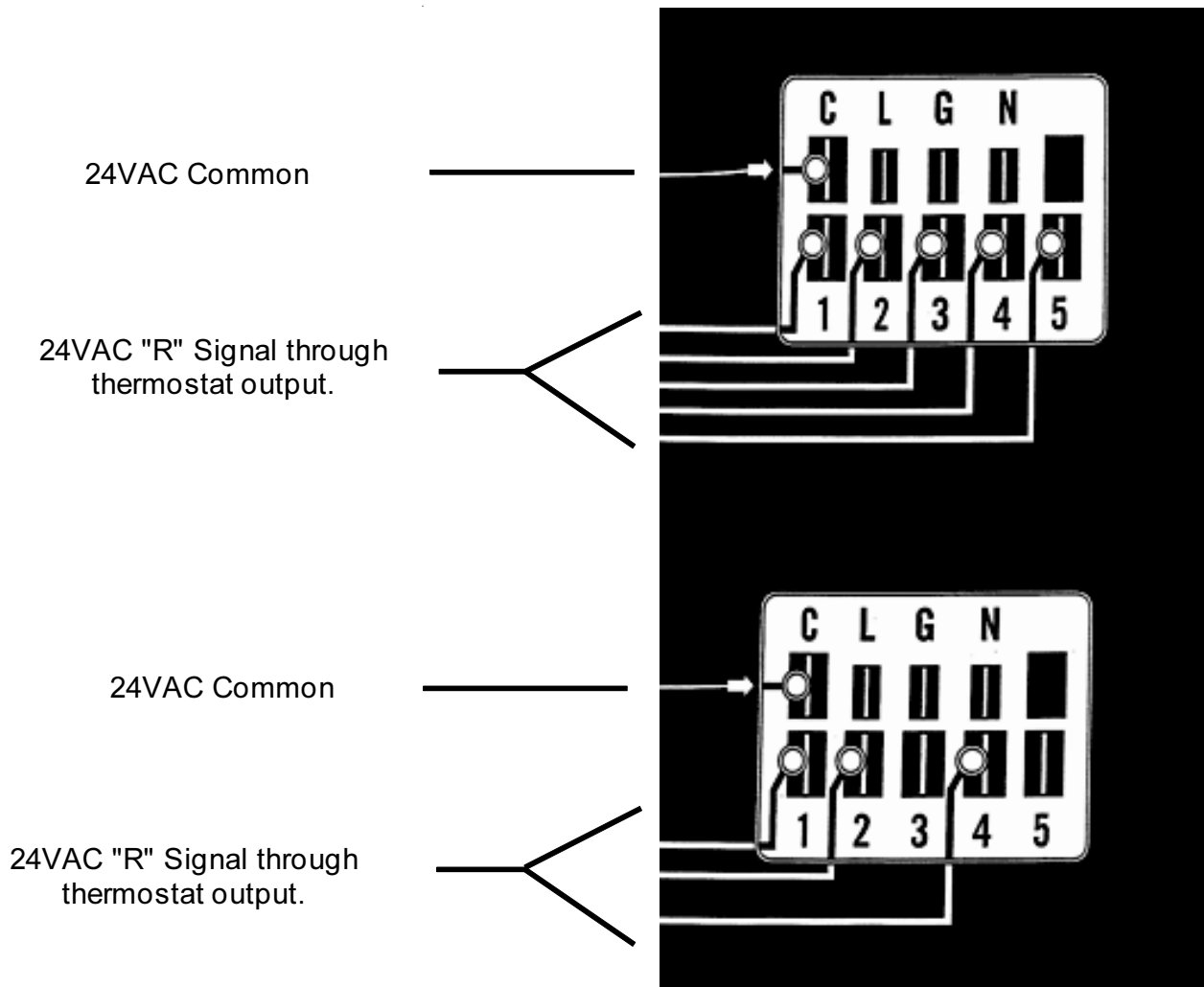
### Model Endura Pro Communication Diagnostics

The Endura Pro motor is communicated through 24 VAC low voltage (Thermostat Control Circuit Wiring).

1. Start with unit wiring diagram to confirm proper connections and voltage (see Figure 18).
2. Initiate a demand from the thermostat and check the voltage between the common and the appropriate motor terminal (1-5). ("G" input is typically on terminal #1, but refer to wiring diagram!)

- A. If the low voltage communication is not present, check the demand from the thermostat. Also check the output terminal and wire(s) from the terminal strip or control relay(s) to the motor.
- B. If the motor has proper high voltage as identified above (Motor not Running #1), and proper low voltage to a programmed terminal, and is not operating, the motor is failed, and will require replacement.

**FIGURE 18**  
Motor Connections



# ACCESSORIES

## ADD-ON GVDM-26 PUMP MODULE KIT

**NOTE:** This section applies only if a GVDM-26 pump module is added. Refer to GVDM-26 instructions for complete installation details.

### GENERAL

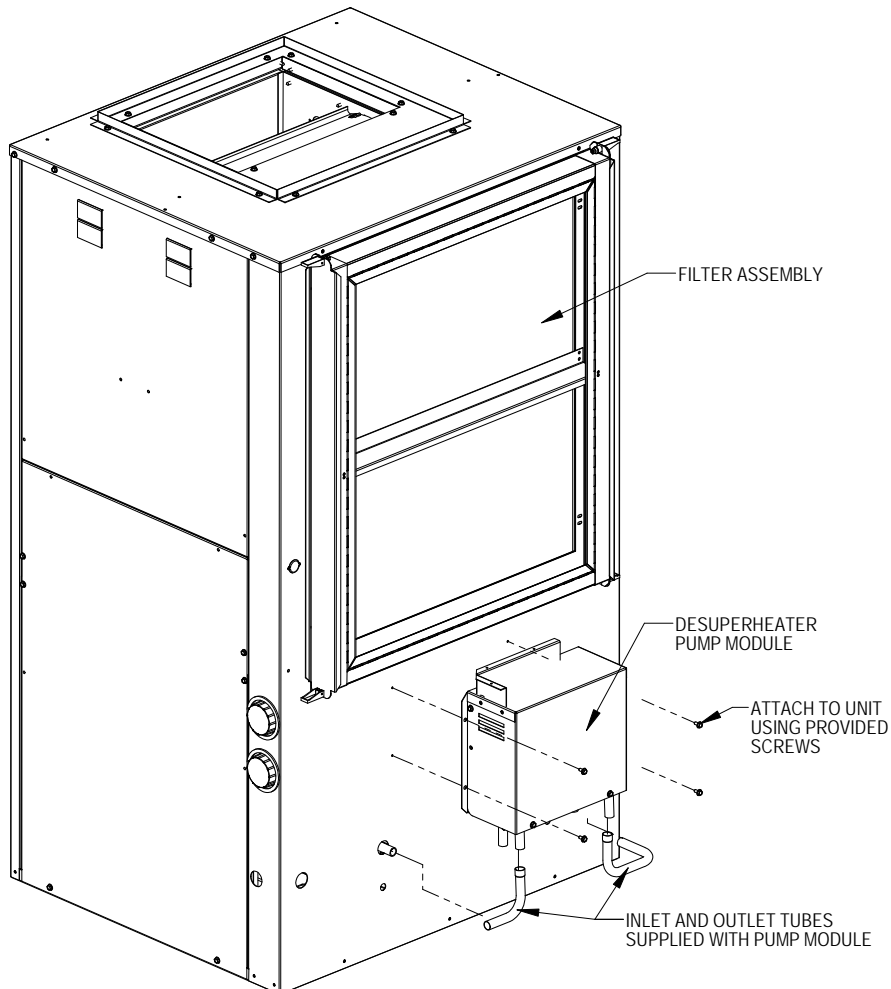
This high efficiency water source heat pump series was designed with a refrigerant to water heat exchanger commonly known as a desuperheater coil factory-installed for ease in installing optional GVDM-26 pump module kit. The addition of this optional kit allows for heat recovery for hot water heating when connected to a home water heater. The amount of annual hot water supplied and thus additional energy cost savings will depend on the amount of hot water usage and the number of hours the heat pump operates. This pump kit is suitable for potable water.

## INSTALLATION

1. Follow all local, state and national codes applicable to the installation of the pump module kit.
2. Follow the installation instructions received with the GVDM-26 pump module kit.
3. Connect the water lines between the unit, pump module kit and the water heater.
4. Pump power is 115V-60Hz 1-phase. A 6' 3-prong cord is supplied. Pump control is accomplished by 18 gauge 3-wire connection (field supplied) from pump module to the GV heat pump 24V terminal strip.

**NOTE:** The GVDM-26 pump module can be installed on adjacent surface or nearer to hot water storage tank if that better facilitates the plumbing or electrical connection.

**FIGURE 19**  
Typical Pump Kit Connection to Unit



MIS-2647 B

# Ground Source Heat Pump Performance Report

Date: \_\_\_\_\_ Technician: \_\_\_\_\_

Company Reporting: \_\_\_\_\_ Contact Phone: \_\_\_\_\_

Owner's Name: \_\_\_\_\_ Owner's Address: \_\_\_\_\_

1. Model/Serial Numbers: (For 3-Pc. Geo-Trio system, include coil/compressor/blower information)

- Model Number(s): \_\_\_\_\_
- Serial Number(s): \_\_\_\_\_

2. Accessory Information:

- Thermostat Mfgr. \_\_\_\_\_ Model/Part Number: \_\_\_\_\_
- Flow-Center\* Mfgr. \_\_\_\_\_ Model/Part Number: \_\_\_\_\_  
\*if applicable

3. Open-Loop Water Source Information:

- Where/how is water discharged \_\_\_\_\_

4. Closed-Loop Water Source Information:

- Horizontal Trenches       Horizontally Bored       Vertical       Pond/Lake  
 Other (Describe) \_\_\_\_\_

- Type of Antifreeze \_\_\_\_\_ % of Antifreeze \_\_\_\_\_ Freezepoint °F \_\_\_\_\_
- Piping Material \_\_\_\_\_ Diameter of Loop Pipe \_\_\_\_\_ Diameter of Header Pipe \_\_\_\_\_
- Length of Loops \_\_\_\_\_ Pressurized/Non-Pressurized Flow Center \_\_\_\_\_
- If Horz. Trench: Loops per trench \_\_\_\_\_ L x W x D of trenches \_\_\_\_\_  
Total Number of Trenches \_\_\_\_\_ Total Number of Loops \_\_\_\_\_
- If Horz. Bored: Avg. Depth of Bores \_\_\_\_\_ Grout was used (Y/N) \_\_\_\_\_  
Total Number of Bores \_\_\_\_\_ Total Number of Loops \_\_\_\_\_
- If Vert. Bored: Depth of Bores \_\_\_\_\_ Grout was used (Y/N) \_\_\_\_\_  
Total Number of Bores \_\_\_\_\_ Total Number of Loops \_\_\_\_\_
- If Pond/Lake: Approx. Acreage of Pond/Lake \_\_\_\_\_ Depth of Loops \_\_\_\_\_  
Style of Loops: (coils, mats, Lake Plates) \_\_\_\_\_ Total Number of Loops \_\_\_\_\_

General Notes: \_\_\_\_\_

\_\_\_\_\_  
\_\_\_\_\_

**The following information is needed to verify performance of the system.**

**Note:** Before testing, disable desuperheater, auxiliary electric heat, and any ventilation equipment that may allow outdoor air into the system. Measurements should be taken after a minimum 10 min. run time to ensure “steady-state” of operation. Temperature and pressure measurements should be taken with a single thermometer and pressure gauge to eliminate discrepancies between multiple devices.

<b>Fluid Data:</b>	<b>1<sup>st</sup> Stg. Cool</b>	<b>2<sup>nd</sup> Stg. Cool</b>	<b>1<sup>st</sup> Stg. Heat</b>	<b>2<sup>nd</sup> Stg. Heat</b>
5. Entering Fluid Temperature °F	_____	_____	_____	_____
6. Leaving Fluid Temperature °F	_____	_____	_____	_____
7. Entering Fluid Pressure psi	_____	_____	_____	_____
8. Leaving Fluid Pressure psi	_____	_____	_____	_____
9. Pressure Drop through coil (psi)	_____	_____	_____	_____

*Using the specific model number and pressure drop, refer to Water Coil Pressure Drop Chart on page 6 to find gallons-per-minute flow through water coil.*

10. GPM through coil	_____	_____	_____	_____
----------------------	-------	-------	-------	-------

<b>Air Data:</b>	<b>1<sup>st</sup> Stg. Cool</b>	<b>2<sup>nd</sup> Stg. Cool</b>	<b>1<sup>st</sup> Stg. Heat</b>	<b>2<sup>nd</sup> Stg. Heat</b>
11. Dry Bulb Return Air Temp °F	_____	_____	_____	_____
12. Wet Bulb Return Air Temp °F	_____	_____	_____	_____
13. Dry Bulb Supply Temperature °F	_____	_____	_____	_____
14. Wet Bulb Supply Air Temp °F	_____	_____	_____	_____
15. Return Static Pressure “WC	_____	_____	_____	_____
16. Supply Static Pressure “WC	_____	_____	_____	_____

<b>Refrigerant Data:</b>	<b>1<sup>st</sup> Stg. Cool</b>	<b>2<sup>nd</sup> Stg. Cool</b>	<b>1<sup>st</sup> Stg. Heat</b>	<b>2<sup>nd</sup> Stg. Heat</b>
17. Head Pressure psi	_____	_____	_____	_____
18. Suction Pressure psi	_____	_____	_____	_____
19. Liquid Line Temperature °F	_____	_____	_____	_____

Note: Liquid line temperature should be measure directly before metering device.

20. Suction Line Temperature °F	_____	_____	_____	_____
---------------------------------	-------	-------	-------	-------

Note: Suction line temperature should be measured approximately 6” from compressor.

*Calculate the subcooling from line #17 and Line #19 (Typically 10°F to 30°F)*

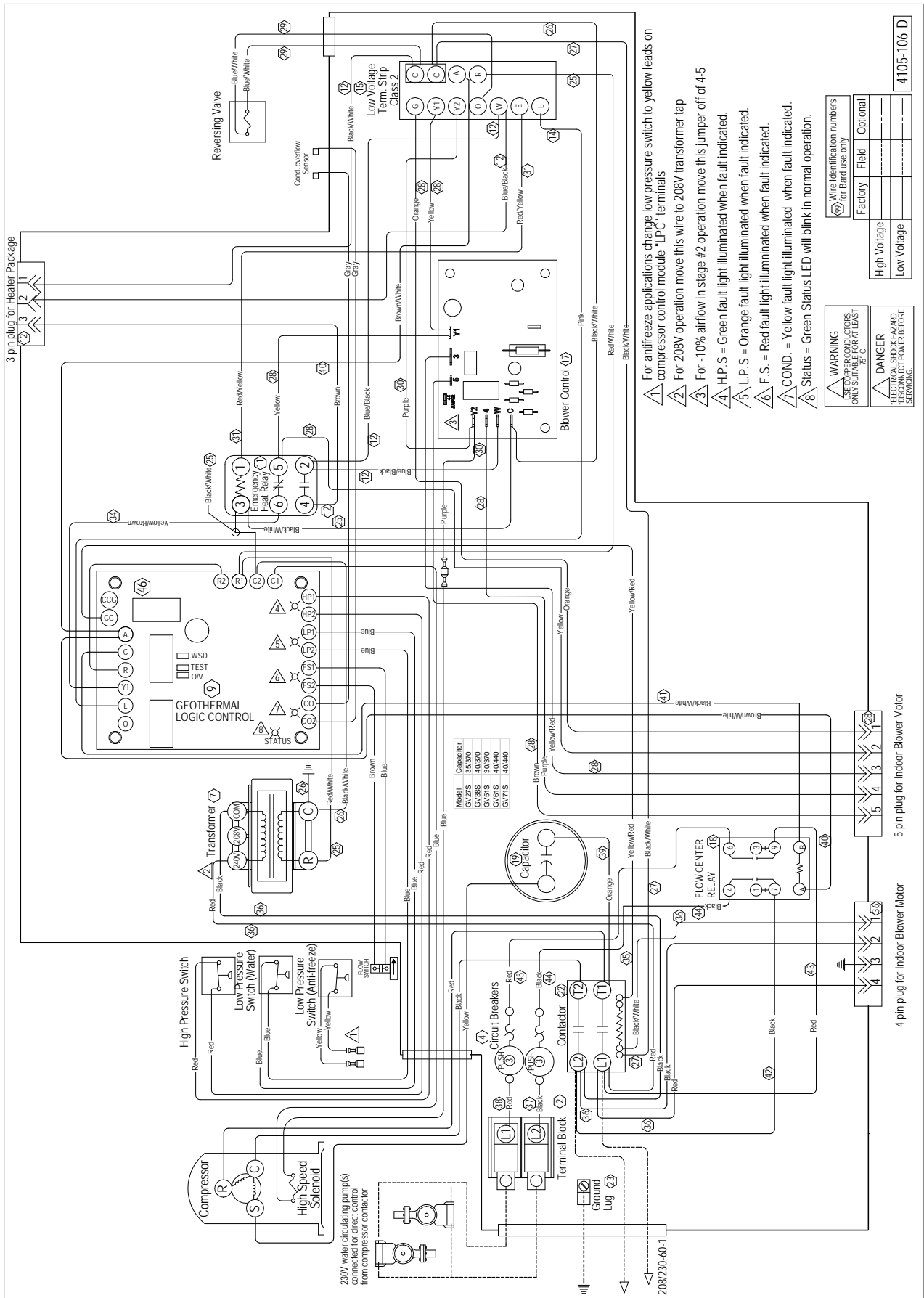
21. Coil Subcooling °F	_____	_____	_____	_____
------------------------	-------	-------	-------	-------

*Calculate the superheat from line #18 and Line #20 (Typically 6°F to 12°F)*

22. Coil Superheat °F	_____	_____	_____	_____
-----------------------	-------	-------	-------	-------

<b>Electrical Data:</b>	<b>1<sup>st</sup> Stg. Cool</b>	<b>2<sup>nd</sup> Stg. Cool</b>	<b>1<sup>st</sup> Stg. Heat</b>	<b>2<sup>nd</sup> Stg. Heat</b>
23. Voltage at Load Side of Contactor	_____	_____	_____	_____
Note: Voltage must be within 197VAC to 253VAC (for 208V/230V), 414VAC to 506VAC (for 460V)				
24. Amperage Draw of Compressor	_____	_____	_____	_____
25. Amperage Draw of Blower Motor	_____	_____	_____	_____

Note: consult Electrical Table on page 5 to compare against typical run load amps.



- ⚠ For antifreeze applications change low pressure switch to yellow leads on compressor control module "LPC" terminals
- ⚠ For 208V operation move this wire to 208V transformer tap
- ⚠ For -10% airflow in stage #2 operation move this jumper off of 4-5
- ⚠ H.P.S = Green fault light illuminated when fault indicated.
- ⚠ L.P.S = Orange fault light illuminated when fault indicated.
- ⚠ F.S. = Red fault light illuminated when fault indicated.
- ⚠ COND. = Yellow fault light illuminated when fault indicated.
- ⚠ Status = Green Status LED will blink in normal operation.

WARNING	
USE COPPER CONDUCTORS ONLY SUITABLE FOR AT LEAST 35 C.	
DANGER ELECTRICAL SHOCK HAZARD DISCONNECT POWER BEFORE SERVICING.	

Wire Identification numbers for Bard use only.	Factory	Field	Optional
High Voltage			
Low Voltage			

4105-106 D