INSTALLATION INSTRUCTIONS & REPLACEMENT PARTS LIST

MC4002 Series Solid State Dual Unit Lead/Lag Controller



Climate Control Solutions

Bard Manufacturing Company, Inc.
Bryan, Ohio 43506
www.bardhvac.com

Manual : 2100-614L
Supersedes: 2100-614K
Date: 8-16-21

CONTENTS

Getting Other Information and Publications.....	3
Shipping Damage	3
General.....	3
Theory of Operation	3
Controller Certifications.....	4
Specifications/Features for Basic Controller.....	4
Mounting the Controller.....	4
Temperature Sensors.....	4
Temperature Sensor Logic	5
Basic MC4002 Controller Input/Output Specifications..	5
MC4002 Controller Connections	5
Specifications/Features for Alarm Boards	6
MC4002-A with Optional Base Alarm	6
MC4002-B with Enhanced Version Alarm.....	6
Low Voltage Field Wiring	6
Controller Grounding.....	6
Controller Power-Up.....	6
Fire Suppression Circuit.....	6
Staging Delay Periods	7
Blower Operation	7
Advance (Swap) Lead/Lag Unit Feature.....	7
Accelerate Timer Feature.....	7
General Programming Overview	8
Humidity Reduction Options.....	9
Synchronized Dehumidification Option	9
Hot Gas Reheat Dehumidification Option	10
Cooling Operating Sequences for Alternating Lead/Lag/Lead/Lag Configuration.....	11
Cooling Operating Sequences for Non-Alternating Lead/Lead/Lag/Lag Configuration.....	13
Heating Sequence of Operation.....	15
Specifications for Optional Remote Communication Board	15
Controller Wiring.....	23
Security (Locking) Feature.....	23
Generator Run Feature	23
Backup DC Power Connection	23
Controller Connections Diagrams.....	24
Single Unit Application for MC4002 with Alarm Board.....	53
Alarm Wiring	54
2nd Stage Cooling Alarm	54
Refrigerant Pressure Alarms.....	54
Emergency Ventilation Sequence.....	54
Programming Instructions.....	57
Parts List.....	60

FIGURES

Figure 1	Mechanical Humidistat Connection for "D" Dehumidification Models	9
Figure 2	Electronic Humidistat Connection for "D" Dehumidification Models	10
Figure 3	Alarm Board Connections for Normally Closed "NC" Open-On-Alarm Strategy	55
Figure 4	Alarm Board Connections for Normally Open "NO" Close-On-Alarm Strategy	56
Figure 5	Parts List Description Diagram	59

TABLES

Table 1	Controller Connections Diagrams Index....	24
Table 2	Temperature Sensor Table	61

GETTING OTHER INFORMATION AND PUBLICATIONS

These publications can help when installing the air conditioner or heat pump. They can usually be found at the local library or purchased directly from the publisher. Be sure to consult the current edition of each standard.

Standard for the InstallationANSI/NFPA 90A of Air Conditioning and Ventilating Systems

Standard for Warm Air Heating.....ANSI/NFPA 90B and Air Conditioning Systems

For more information, contact these publishers:

ACCA Air Conditioning Contractors of America
1712 New Hampshire Avenue, NW

Washington, DC 20009
Telephone: (202) 483-9370
Fax: (202) 234-4721

ANSI American National Standards Institute

11 West Street, 13th Floor
New York, NY 10036
Telephone: (212) 642-4900
Fax: (212) 302-1286

ASHRAE American Society of Heating, Refrigerating, and Air Conditioning Engineers, Inc.

1791 Tullie Circle, N.E.
Atlanta, GA 30329-2305
Telephone: (404) 636-8400
Fax: (404) 321-5478

BARD Bard Manufacturing Company, Inc.

1914 Randolph Drive
Bryan, OH 43506
Telephone: (419) 636-1194
Fax: (419) 636-2640

**** IMPORTANT ****

The equipment covered in this manual is to be installed by trained, experienced service and installation technicians. Please read entire manual before proceeding.

SHIPPING DAMAGE

Upon receipt of equipment, the carton should be checked for external signs of shipping damage. If damage is found, the receiving party must contact the last carrier immediately, preferably in writing, requesting inspection by the carrier's agent.

GENERAL

These instructions explain the operation, installation and troubleshooting of the MC4002 controller.

All internal wiring is complete. Only attach low voltage field wiring to designated terminal strips.

The MC4002 is for use with units with or without economizers, can be configured for use with heat pumps, and has a dehumidification control feature if an optional humidity controller is connected. Dehumidification control cannot be used with heat pump.

Each unit should be sized to handle the total load of the structure if 100% redundancy is required.

It is recommended that a 5-minute compressor time delay relay be installed in each unit if not so equipped.

The MC4002 controller is suitable for both 50 and 60 HZ operation, and is fully configurable such that it can be used in virtually any installation. See Controller Programmable Features and Default Settings.

THEORY OF OPERATION

The controller is used to control two wall mount air conditioners from one control system. It provides total redundancy for the structure and equal wear on both units. It can be used with units with or without economizers and it is recommended that both units be equipped alike.

The MC4002 controller can be configured for alternative (lead/lag/lead/lag) sequence, which is default setting. It can be changed to non-alternating (lead/lead/lag/lag) sequence as required for special applications or user preference.

The MC4002 can be equipped with one of two alarm boards, and these can be factory-installed or installed at any time in the field if so desired.

Should the base controller alone be initially installed, it is easily upgradeable by simple snap-in, plug-in field installation of either one of the alarm boards, requiring only the connection of the building alarm circuitry to the alarm boards. Form C dry contact alarm relays are used, offering both NO and NC switching to meet the user's specific alarm protocol, providing complete flexibility to meet any user's requirements. All alarm actuations are individually indicated on the controller front panel.

There is an Ethernet-based remote communication option that can be either factory or field installed. See section on Communication Module.

CONTROLLER CERTIFICATIONS

The MC4002 main controller board, optional alarm boards, optional communication module, and remote sensors have undergone extensive testing for immunity and emissions. This system is FCC-compliant, in accordance with CE requirements, and meets the following standards:

MC4002 Series Master Controller



This device complies with FCC Rule Part 15, Subpart B, Class A. Operation is subject to the following two conditions:

1. This device may not cause harmful interference
2. This device must accept any interference received, including that which may cause undesired operation.

This device complies with CE Standards EN55011/ EN50081 and EN55024 for ISM Equipment, Class A.

This ISM device also complies with Canadian ICES – 001.

Bard Manufacturing Company, Inc.
Bryan, OH 43506



**CONFORMS TO UL STD 916
CERTIFIED TO
CSA STD C22.2 NO. 205**

SPECIFICATIONS/FEATURES FOR BASIC CONTROLLER

MC4002 Basic Controller

- Input power: 18-32 VAC, 60/50Hz, power is supplied from A/C #1 and/or A/C #2
- Isolation circuitry: no line or low voltage phasing required
- Backup power: connection for -24 VDC or -48 VDC (-20 to -56V) maintains microprocessor operation, front panel indication & alarm relay operation during commercial power outages.
- Digital display: 4-character LCD
- Temperature display: F or C
- HVAC outputs: Form A (NO) relays (1A @ 24 VAC)
- Cooling control stages:
 - 2 for each A/C unit (4 total) when configured for economizers

1 for each A/C unit (2 total) when configured for no economizers

•Heating Control stages:

1 for each A/C unit, 2 for each heat pump if so configured

- Dehumidification circuit: requires optional humidity controller as input signal
- Operating temperature range: 0 to 120F (-18 to 49C)
- Storage temperature range: -20 to 140F (-29 to 60C)
- Temperature accuracy: +/- 1F from 60-85F (16-30C)
+/- 1% outside 60-85F
- Lead/lag changeover time: 0 to 30 days
- Timing accuracy: +/- 1%
- Inter-stage time delay: 10 seconds between stages
- Inter-stage differential:
 - Stage 1 to 2 - Range 2-6F, default is 4
 - Stage 2 to 3 - Range 2-3F, default is 2
 - Stage 3 to 4 - Range 2-3F, default is 2
- On-Off differential: 2F (1C) is standard, 4F (3C) when "excessive cycling" mode is enabled
- Cooling setpoint range: 65 to 90F (18.3 to 32.2C)
- Comfort setting-Cooling 72F (22C), Heating 68F(20C), for 1 hour
- Dead band (difference between cooling and heating setpoints): 2F to 40F (1.1C to 22.2C)
- Fire/smoke interface: standard NC circuit jumper, remove for connection to building system control, shuts down outputs to both A/C units immediately
- Memory: EEPROM for setpoint and changeable parameters (maintains settings on power loss)
- Space temperature sensors: One (1) local is standard, will accept up to twp (2) optional 35' remote sensors, Bard part number 8612-023B. When multiple sensors are used, temperatures are averaged
- Controller Enclosure: 20-gauge pre-painted steel, 9.25"W x 13.50"H x 3.00"D, hinged cover, thirteen (13) .875" diameter electrical knockouts
- LEDs for basic controller: Lead unit, Cooling stages 1 through 4, Heating Stages 1 – 4, Dehumidification operation
- Six (6) Push-button controls: On/Off switch-Change lead unit-Increase and Decrease setpoints-Program/ Save-Comfort.

MOUNTING THE CONTROLLER

Included in the controller carton is the controller and installation instructions.

The controller should be installed on a vertical wall approximately 4 feet above the floor-away from drafts and outside doors or windows. Four (4) mounting holes are provided for mounting to the wall and 7/8" holes for conduit connections are provided in both the base, sides and top of the controller.

TEMPERATURE SENSORS

The standard (local) temperature sensor has 12" leads and comes installed from the factory.

A secondary sensor is located internally on the main controller board and serves as a reference and back-up sensor to the local sensor. If the difference between the two sensors is less than the differential setpoint, the local sensor will be used as the controller's temperature point of reference. The differential is adjustable from 12-20°F. 12°F is the default setting. If the difference between the two sensors is greater than the differential set-point, then the controller will check to determine if the on-board sensor is reading a temperature that is between the SP (set-point), plus the differential and the SP minus the DB (dead-band) minus the differential. If it is, the on-board sensor will become the valid sensor reading and the controller will ignore the local sensor reading. If not, then the controller, will still use the local sensor reading. This is to add additional levels of operational capability in the rare event the local sensor fails. If the controller is operating in this mode, it is indicated by the lower left decimal point flashing in the display. If this feature is not desired, set the differential set-point to OFF. This disables the on-board sensor. This may be necessary if the controller is located in one room and the local sensor has been relocated to a different room. **NOTE: For purposes of testing when the local sensor is manually driven higher or lower by applying warm or cool water to the probe the on-board sensor is inhibited for the first 30-minutes following power up, or when power is cycled off and back on.**

The controller is designed to accept 1 or 2 additional sensors and those have 35-foot leads. The Bard part number for the optional sensor with 35-foot leads is 8612-023B. These can be installed as required in the structure to address hot spots, barriers to airflow, etc. If a remote sensor(s) is used, the on-board sensor is disabled. The local sensor remains active.

It is recommended that the sensor lead wires be installed in conduit for protective purposes.

NOTE: All sensors are polarity sensitive. The copper lead must connect to terminal CU, and the silver lead to AG. Sensors are solid state, not RTD. Use only sensors supplied by Bard. Sensor leads can be extended up to 200 feet. Use 18-gauge twisted pair with soldered connections.

TEMPERATURE SENSOR LOGIC

The standard local (**LSEn**) sensor monitors the temperature at the controller location. If this is the only sensor connected, it will control the temperature read-out, the space (building) temperature, and also be used for Low and High Temperature alarm functions.

If one or more **REMOTE** sensors are installed and connected (**Rem 1** or **Rem 2**), the temperature read-out will display and the building will be controlled to an **average** of all connected sensors. If there is more than 10F difference from the highest to the lowest connected

sensor, the actual control will be governed by the hottest sensor for cooling and the coldest sensor for heating.

If alarm boards are utilized, the highest reading of any connected sensor will be used for high temperature alarm and the lowest reading sensor will be used for low temperature alarm. The on-board sensor is ignored if two (2) or more sensors are connected to the Local, Rem 1 or Rem 2 sensor inputs.

BASIC MC4002 CONTROLLER INPUT/OUTPUT SPECIFICATIONS

MC4002 Controller Connections Located on Main Controller Board

Unit #1	C – 24VAC common R – 24VAC hot G – fan (Form A, NO) Y1 – 1 st -stage cool (Form A, NO) Y2 – 2 nd -stage cool (Form A, NO) W – heat (Form A, NO)
Unit #2	C – 24VAC common R – 24VAC hot G – fan (Form A, NO) Y1 – 1 st -stage cool (Form A, NO) Y2 – 2 nd -stage cool (Form A, NO) W – heat (Form A, NO)
F1-F2	Fire/smoke interface Shipped with jumper installed (a)
48Vdc	Back-up power input -24Vdc or -48Vdc -20V to -56V range
Local	Main sensor, 12-inch leads CU – copper, AG – silver Polarity sensitive
Rem 1	Optional remote indoor sensor CU – copper, AG – silver Polarity sensitive
Rem 2	Optional remote indoor sensor CU – copper, AG – silver Polarity sensitive
Gen	Generator interface G1-G2 Shipped with jumper installed (a)
H1-H2	Humidity controller input Requires optional controller Field installed

NOTE:

*Sensors are solid state, not RTD.
Use Bard sensors only.*

(a) These connections require either jumper or Normally Closed (NC) relay contact at the Fire/Smoke and Generator interface for Controller to function.

NOTE: All alarm and output relays are dry contacts rated 1A @ 24 VAC.

NOTE: All alarm relay outputs have 10-second delay before issuing to protect against nuisance alarm signals.

Alarm relays can be wired for NO (close on alarm) or NC (open on alarm) strategy. Alarm relays can be used individually if there are enough available building alarm points, or can be arranged into smaller groups or even a single group so that all alarm capabilities can be utilized. When multiple alarms are grouped together and issued as a single alarm there will be no off-site indication of which specific problem may have occurred, only that one of the alarms in the group has been triggered. The individual alarm problem will be displayed on the LED display on face of the controller.

SPECIFICATIONS/FEATURES FOR ALARM BOARDS

MC4002-A w/Optional Base Alarm Board (Inputs/Outputs)

NOTE: If this alarm board was not originally factory installed, it can be field-installed at anytime. Bard part number is AB3000-A.

Inputs

Lockout 1 2,3 – input from HVAC #1
 Lockout 2 2, 3 – input from HVAC #2

Outputs

Smoke/Fire Form C (SPDT)
 Lockout 1 Form C (SPDT)
 Refrigerant alarm HVAC #1
 Lockout 2 Form C (SPDT)
 Refrigerant alarm HVAC #2
 Power Loss 1 Form C (SPDT)
 Power loss HVAC #1
 Power Loss 2 Form C (SPDT)
 Power loss HVAC #2
 Low Temp Form C (SPDT)
 Low temperature alarm
 High Temp 1 Form C (SPDT)
 High temperature alarm #1

MC4002-B w/Enhanced Version Alarm Board (Additional Outputs) plus MC4002-A Inputs/Outputs

NOTE: If this alarm board was not originally factory installed, it can be field-installed at anytime. Bard part number is AB3000-B.

High Temp 2 Form C (SPDT)
 High temperature alarm #2
 Controller Form C (SPDT)
 Controller failure alarm – see note (a)
 Econ 1 E, F - Form A (NO) – see note (b)
 Econ 2 E, F - Form A (NO) – see note (b)
 2nd Stage Form C (SPDT) – see note (c)
 2nd-stage cooling alarm

(a) Alarm will only activate if main board processor fails or if alarm board to main board cable is damaged.

(b) Make these connections to terminals E & F in HVAC 1 and 2 respectively if desired to have economizers open for emergency ventilation at High Temp Alarm #2 setpoint condition.

(c) For units with 2-stage compressors, 2nd stage cooling alarm activates on cooling Stage 3 initiation.

LOW VOLTAGE FIELD WIRING

The MC4002 is powered from the air conditioners that it is controlling, 24 VAC (18-32V) low voltage only.

Circuitry in the MC4002 isolates the power supplies of the two air conditioners so that no back feeds or phasing problems can occur. Additionally, if one air conditioner loses power, the MC4002 and the other air conditioner are unaffected and will continue to operate normally.

Connect the low voltage field wiring from each unit per the low voltage field wiring diagrams in Section on “Controller Wiring”. **NOTE:** Maximum of 18-gauge control wiring should be used. Using heavier gauge wiring can create excessive stress on the control board as door is opened and closed. Create a wiring loop so the door can open and close without stressing terminal blocks.

CONTROLLER GROUNDING

A reliable, verified earth ground must be connected in addition to any grounding from conduit. Grounding lugs are supplied for this purpose. All other alternative grounding methods must meet all applicable national, state and local codes per the product application.

CONTROLLER POWER-UP

Whenever power is first applied to the controller, there is a twenty (20) second time-delay prior to any function (other than display) becoming active. This time-delay is in effect if the controller On/Off button is used when 24VAC from air conditioners is present, and also if controller is in “ON” position and 24VAC from air conditioners is removed and then restored.

FIRE SUPPRESSION CIRCUIT

To disable the MC4002 and shut down both air conditioners, terminals F1 and F2 may be used. The F1 and F2 terminals must be jumpered together for normal operation. A normally closed (nc) set of dry contacts may be connected across the terminals and the factory jumper removed for use with a field-installed fire suppression system. The contacts must open if a fire is detected. See appropriate connection diagram - Figures 1, 2 or 3 for this connection. Contacts should be rated for pilot duty operation at 2 amp 24VAC minimum. Shielded wire (22-gauge minimum) must be used, and the shield must be grounded to the controller enclosure.

IMPORTANT NOTE: Older Bard R-22 models employ an electronic blower control that has a 60-second blower off-delay. Current production R-410A models do not use a blower off-delay device and the remainder of this (paragraph) does not apply. In order to have immediate shutdown of the blower motor, in addition to disabling the run function of the air conditioners will require a simple wiring modification at the blower control located in the electrical control panel of the air conditioners being controlled by the lead/lag controller. To eliminate the 60-second blower off-delay, disconnect and isolate the wire that is factory-connected to the "R" terminal on the electronic blower control, and then connect a jumper from the "G" terminal on the blower control to the "R" terminal on the blower control. The electronic blower control will now function as an on-off relay with no off-delay, and the blower motor will stop running immediately when the F1-F2 fire suppression circuit is activated (opened).

STAGING DELAY PERIODS

The following delays are built in for both cooling and heating:

- Stage 1** – 0 seconds for blower (if not already on as continuous)
10 seconds for cooling or heating output
- Stage 2** – 10 seconds after Stage 1 for blower
10 additional seconds for cooling or heating output
- Stage 3** – 10 seconds after Stage 2
- Stage 4** – 10 seconds after Stage 3

NOTE: For cooling Stages 1 and 2, the stage LED will blink for 10 seconds while the cooling output is delayed after that stage is called for. There is also a delay after the stage is satisfied, and after the LED stops blinking, the stage will turn off. There is a minimum 10-second delay between stages 2 & 3, and 3 & 4, but no delayed output when stage is turned on or off, and LED for those stages will not blink.

BLOWER OPERATION

The controller can be configured to have main HVAC blowers cycle on and off on demand; have all blowers run continuously; or have the lead unit blower run continuously with the lag unit blower cycling on demand. Default setting is the blower(s) start and stop on demand. There is also an option to have all blowers cycle on if one remote sensor is connected, and a temperature difference of more than 5F between any two sensors is observed. This helps to redistribute the heat load within the structure and should reduce compressor operating time.

When any of the stages are satisfied, the stage LED will blink for ten (10) seconds before the stage is actually turned off.

ADVANCE (SWAP) LEAD/LAG UNIT FEATURE

Pressing the Advance button for one (1) second will cause the lead and lag units to change positions. This may be useful during service and maintenance procedures. This function not available when LLCO is set to zero.

ACCELERATE TIMER FEATURE

Pressing the UP arrow button for five (5) seconds will activate an accelerate (speed-up) mode, causing the normal changeover time increments of days to be reduced to seconds. Example: 7 days becomes 7 seconds. When "ACC" displays, release button. Whichever LED is on, indicating lead unit will blink over for each second until the controller switches. This is a check for the timer functionality.

GENERAL PROGRAMMING OVERVIEW

MC4002 CONTROLLER BUTTONS AND FUNCTION

On/Off Button

1. Press and release the On/Off button to turn On controller, 4-character display will illuminate and Lead unit LED will light.
2. Press and release the On/Off button to turn Off controller. Controller will go dark and A/C units will stop.

Comfort Button

1. Press and release the Comfort button to change the Cooling Setpoint to 72F and the Heating Setpoint to 68F for a period of 1 hour.
2. Setpoints will return to the programmed settings automatically after 1 hour.
3. Pressing the Comfort button during the 1 hour period will deactivate the Setpoint change.
4. The temperature display will flash the current temperature while in override mode.

Program Button

1. Press the Program button and release it when the message “Prog” appears on the display.
2. Refer to Programming Instructions and follow these commands to change from Default settings.

Advance/Change/Save Button

1. Press and release the Advance button to swap lead and lag unit positions.
2. When in Program mode the Down and Up buttons are used to scroll through the programming steps.
3. A flashing display means that the particular function of that programming step is “set”, and the display will alternate between the step function and the setting.
4. To change the setting press the Change button and the display will stop flashing, allowing change to the setting.
5. Use Down or Up arrows to change setting as desired, and press the Save button and proceed as desired.
6. When done with programming changes press the Program button until display stops flashing and room temperature is shown.

Up and Down Buttons

These buttons are used to change the settings in conjunction with the Advance/Change/Save button when in programming mode.

CONTROLLER PROGRAMMABLE FEATURES AND DEFAULT SETTINGS

Order/Display	Description	Range/Choice	Default
LSEn	Temperature at local (main) sensor	—	—
SP	Cooling setpoint temperature	65 to 90F (18 to 32C)	77F (25C)
db	Deadband between cooling SP and heating setpoint	2 to 40F (1 to 24C)	17F (9.4C)
r1	Temperature at remote sensor 1 location, if connected	—	—
r2	Temperature at remote sensor 2 location, if connected	—	—
cFAn	Continuous blower operation	None, Lead, Both	None
deg	Controller system operates in F or C	F or C	F
Alt	Alternating Lead-Lag-Lead-Lag sequence or Non-Alternating Lead-Lead-Lag-Lag sequence — Yes = Alternating	Yes or No	Yes
LLCO	Lead-Lag changeover time (Days)	1 - 30 days, or 0 for disabled	7
HP	Heat pump logic enabled — only for 1-stage heat pumps and forces Lead-Lag sequence (overrides a Non-Alt setting)	Yes or No	No
Cbd5	Unit 1 and 2 blowers automatically both run if delta T >5F between any 2 connected sensors	Yes or No	Yes
OFde	3-minute lead unit & 4-minute lag unit off-delay enabled	Yes or No	No
crun	Minimum 3-minute compressor runtime enabled	Yes or No	No
LoAL	Low temperature alarm setpoint	28 to 65F (-2 to 18C)	45F (7.2C)
HAL1	High temperature alarm level #1 setpoint	70F to 120F (21 to 49C)	90F (32C)
HAL2	High temperature alarm level #2 setpoint	70F to 120F (21 to 49C)	95F (35C)
Locd	Controller is locked and no changes can be made. Consult building authority.	If locked, display will show Locd if changes attempted	Unlocked
Inter-Stage Differential			
ISd2	From Stage 1 to Stage 2	2, 3, 4, 5 or 6F	4
ISd3	From Stage 2 to Stage 3	2 or 3F	2
ISd4	From Stage 3 to Stage 4	2 or 3F	2
On/Off Differential (Hysteresis)			
CSon	Turn "On" above SP for Stage 1 Cooling	+1 or 2F	2
CSoF	Turn "Off" below SP for Stage 1 Cooling	-1, 2, 3 or 4F	-2
	Stage 2, 3 and 4 Cooling automatically set same as Stage 1 decisions		
HSoo	All Heating Stages are equal +/- on & off differential	-1/+1 or -2/+2	-2/+2
CoPr	1 or 2-stage compressor, if set to 1 the 2nd stage Cooling Alarm activates on Cooling Call 2, if set to 2 the 2nd stage Cooling Alarm activates on Cooling Call 3	1 or 2	1
ob5d	Differential between Local and On-Board Sensor	12 to 20, OFF	12

HUMIDITY REDUCTION OPTIONS

The MC4002 does not include an indoor humidity sensor, and humidity reduction operation will require additional equipment installation. The following two methods are typically used with the MC4002 to reduce humidity.

- A humidistat may be connected to the controller. When a humidistat is connected to the MC4002, it will be used to operate one wall mount in heating and one wall mount in cooling for a limited period of time when humidity levels are above the humidistat setpoint. This method of humidity control is referred to as **synchronized dehumidification**. Two wall mount units must be installed and operated using the MC4002. When purchasing equipment to be used with this humidity reduction method, it is important to have electric heat installed in both units and both units to have matching heating and cooling capacities.
- Another method of humidity control is when one or both wall mount units are purchased with hot gas reheat dehumidification coils installed (“D” model option). A humidistat is connected directly to each of the wall mount units that have the hot gas reheat option. When the humidity level rises above the humidistat setpoint, the unit will operate in dehumidification mode. This method of humidity control is referred to as **hot gas reheat dehumidification**. One or two wall mount units can be connected directly to humidistats when used

to reduce humidity levels. Each wall mount unit is connected independently of the MC4002 controller for hot gas reheat humidity reduction and will not alternate using lead/lag operation when running in dehumidification mode. Cooling and heating operation will use lead/lag operation controlled by the MC4002. When purchasing equipment to be used with this humidity reduction method, it is important that one or both wall mount units include the “D” hot gas reheat dehumidification option.

Synchronized Dehumidification Option

NOTE: This function is not available if controller is configured for heat pump.

The standard wall mount air conditioning system can be adapted to perform dehumidification control by addition of a simple humidistat that closes-on-rise and is connected to terminals H1 and H2 on the main controller board. See Figure 1 for connection of the humidistat. The recommended humidistat is Bard P/N 8403-038 (H600A 1014). Both HVAC units must be equipped with electric heat for this sequence to work properly.

Sequence of operation with default setpoints:

1. Temperature control always has priority over dehumidification. If there is any stage of cooling demand active, the dehumidification sequence is locked out by the MC4002 logic.

FIGURE 1
Mechanical Humidistat Connection for "D" Dehumidification Models

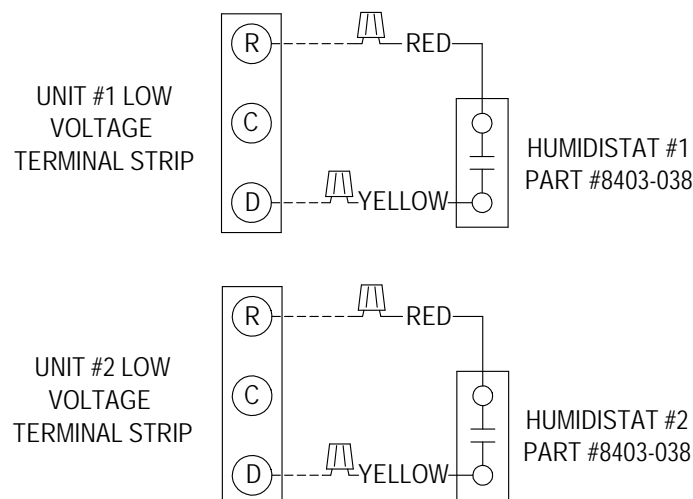

- NOTES:
- 1.) SEPARATE HUMIDISTAT IS REQUIRED FOR "D" DEHUMIDIFICATION UNIT OPERATION.
 - 2.) TH, TS, CH, AND OLDER WA**/WH** MODELS DO NOT HAVE A "D" TERMINAL ON THE LOW VOLTAGE TERMINAL STRIP. MODELS THAT DO NOT HAVE THE "D" TERMINAL USE THE "W3" TERMINAL. REVIEW LOW VOLTAGE TERMINAL STRIP CONNECTIONS PROVIDED IN UNIT INSTALLATION INSTRUCTIONS.

MIS-4304A

2. If all stages of cooling are satisfied, and relative humidity is above the set point of humidity controller:
 - A. The green “Dehumidification Operation” light will come on and the lag unit compressor (Y1 and Y2) and blower (G) will operate until the setpoint of humidity controller is satisfied (or cancelled by a call for cooling).
 - B. If the space temperature drops to 67°F, the electric heater (W) of the lead unit will cycle to help maintain building temperature. It will cycle off at 69°F.
 - C. If space temperature drops to 64°F, the Stage 2 Heating light will come on and the lag unit compressor operating for dehumidification mode will cycle off until the building temperature rises above 65°F from 1st stage heat and building load. The green “Dehumidification Operation” light stays on during this sequence and when Stage 2 Heating light is Off, the compressor is On. The electric heater in lag unit is locked out in dehumidification mode.

Lag unit controller 24VAC outputs G, Y1 and Y2 are all energized during dehumidification sequence. This is true for both alternating and non-alternating controller configurations.

Hot Gas Reheat Dehumidification Option

A hot gas dehumidification wall mount air conditioning system can perform dehumidification control by addition of a humidistat that closes-on-rise, and is connected to the “D” terminal on the unit low voltage terminal strip. See Figure 2 for connection of the humidistat. The recommended humidistat is Bard Part #8403-038 or #8403-047. One or both units must be equipped with the “D” hot gas reheat dehumidification option. Dehumidification operation will be independent from the MC4002 controller.

Sequence of operation with default set points:

1. Temperature control always has priority over dehumidification regarding individual unit operation. If there is any stage of cooling demand active, the dehumidification sequence is locked out by the wall mount unit. It is possible, however, if only a single stage of cooling or heating is required that can be met with operation of the lead unit, the lag unit can still run in dehumidification mode.
2. If all stages of cooling are satisfied, and relative humidity is above the setpoint of humidity controller:
 - A. The humidistat will call for dehumidification operation by sending a signal directly to the wall mount unit (D). This operation will continue until the humidity level falls below the humidistat setpoint.

FIGURE 2
Electronic Humidistat Connection for "D" Dehumidification Models

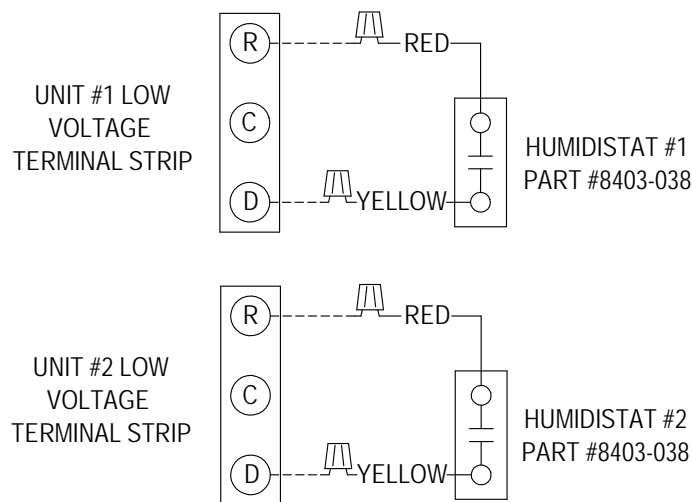

- NOTES:
- 1.) SEPARATE HUMIDISTAT IS REQUIRED FOR "D" DEHUMIDIFICATION UNIT OPERATION.
 - 2.) TH, TS, CH, AND OLDER WA**/WH** MODELS DO NOT HAVE A "D" TERMINAL ON THE LOW VOLTAGE TERMINAL STRIP. MODELS THAT DO NOT HAVE THE "D" TERMINAL USE THE "W3" TERMINAL. REVIEW LOW VOLTAGE TERMINAL STRIP CONNECTIONS PROVIDED IN UNIT INSTALLATION INSTRUCTIONS.

MIS-4304B

- B. If the space temperature rises above the cooling setpoint of the MC4002, the unit will receive a signal to operate in cooling mode (Y1, Y2). The wall mount unit will still receive a signal for dehumidification operation (D) but the cooling call will override the dehumidification call.
- C. If the space temperature falls below the heating setpoint of the MC4002, the unit will receive a signal to operate in heating mode (W). The wall mount unit will still receive a signal for dehumidification operation (D) but the heating call will override the dehumidification call.

Hot gas reheat dehumidification operation is controlled separately from the MC4002 using a humidistat and remote communication regarding humidity level or setpoint adjustment through SNMP or the webpages is not possible. Emergency shutdown features of the MC4002 will not shut down units connected to the controller. Unit shutdown by removing the jumper between the “R” and “RT” terminals on the unit low voltage terminal strip and installing a relay to disable unit low voltage power will shut down the units connected to the MC4002 controller.

Each unit using hot gas reheat dehumidification will require a separate humidistat. Dehumidification staging is only possible by using offset values in each humidistat. An example would be setting the first humidistat/wall mount unit to 60% RH and the second humidistat/wall mount unit to 65% RH. The first humidistat/wall mount unit will operate when the room reaches 60% RH. The second humidistat/wall mount unit will operate when the room reaches 65% RH. The lead unit regarding dehumidification operation will not rotate.

	<h2>CAUTION</h2>
<p>Humidity controller setpoint should be in 50-60% relative humidity area: Setting controller to lower settings will result in excessive operating time and operating costs for the electric reheat, and in extreme cases could cause evaporator (indoor) coil freeze-up if there are periods of light internal equipment (heat) loading.</p>	

COOLING OPERATING SEQUENCES FOR ALTERNATING LEAD/LAG/LEAD/LAG CONFIGURATION

<h1>IMPORTANT</h1>
<p>Balanced Climate™ mode is not available when W**AC series units are used with the MC4002 controller.</p>

1. 1-Stage Compressor Units No Economizer

1st stage cooling setpoint is the setting (SP) input into the controller. Factory default is 77F (25C). On a call for cooling the blower of the lead unit will come on immediately (if not already on – See Blower Operation), and the Stage 1 LED will blink for 10-seconds before going solid, at which time the compressor will start.

2nd cooling setpoint is 4F (default setting, user selectable 2-6F) warmer than Stage 1. On a call for 2nd Stage cooling the blower of the lag unit is turned on (if not already on – See Blower Operation), and the Stage 2 LED will blink for 10-seconds before going solid, at which time the compressor will start.

3rd and 4th stages are functional outputs but there is nothing to be controlled.

2. 2-Stage Compressor Units No Economizer

1st stage cooling setpoint is the setting (SP) input into the controller. Factory default is 77F (25C). On a call for cooling the blower of the lead unit will come on immediately (if not already on – See Blower Operation), and the Stage 1 LED will blink for 10-seconds before going solid, at which time the lead unit compressor will start in compressor Stage 1 partial capacity operation.

2nd cooling setpoint is 4F (default setting, user selectable 2-6F) warmer than Stage 1. On a call for 2nd Stage cooling the blower of the lag unit is turned on (if not already on – See Blower Operation), and the Stage 2 LED will blink for 10-seconds before going solid, at which time the lag unit compressor will start in compressor Stage 1 partial capacity operation.

3rd cooling setpoint is 2F (default setting, user selectable 2-3F) warmer than Stage 2. On a call for 3rd Stage cooling the Stage 3 LED comes on solid (no delay), and the lead unit compressor will switch to compressor Stage 2 full capacity operation.

4th cooling setpoint is 2F (default setting, user selectable 2-3F) warmer than Stage 3. On a call for 4th Stage cooling the Stage 4 LED comes on solid (no delay), and the lag unit compressor will switch to compressor Stage 2 full capacity operation.

3. 1-Stage Compressor Units with EIFM Economizers (Enthalpy OD Sensor)

1st stage cooling setpoint is the setting (SP) input into the controller. Factory default is 77F (25C). On a call for cooling the blower of the lead unit will come on immediately (if not already on – See Blower Operation), and the Stage 1 LED will blink for 10-seconds before going solid, at which time the lead unit Y1 cooling output turns on. If the outdoor temperature and humidity conditions are below the setpoint of the economizer control the lead unit economizer will operate instead of the compressor. If outdoor conditions are not acceptable for free cooling the compressor will automatically operate instead of the economizer.

2nd cooling setpoint is 4F (default setting, user selectable 2-6F) warmer than Stage 1. On a call for 2nd Stage cooling the blower of the lag unit is turned on (if not already on – See Blower Operation), and the Stage 2 LED will blink for 10-seconds before going solid, at which time the lag unit Y1 cooling output turns on. If the outdoor temperature and humidity conditions are below the setpoint of the economizer control the lag unit economizer will operate instead of the compressor. If outdoor conditions are not acceptable for free cooling the compressor will automatically operate instead of the economizer.

3rd cooling setpoint is 2F (default setting, user selectable 2-3F) warmer than Stage 2. On a call for 3rd Stage cooling the lead unit economizer will close and the compressor will operate.

4th cooling setpoint is 2F (default setting, user selectable 2-3F) warmer than Stage 3. On a call for 4th Stage cooling the lag unit economizer will close and the compressor will operate.

4. 1-Stage Compressor Units with ECONWM* or WECOP Economizers (See Note A)

1st stage cooling setpoint is the setting (SP) input into the controller. Factory default is 77F (25C). On a call for cooling the blower of the lead unit will come on immediately (if not already on – See Blower Operation), and the Stage 1 LED will blink for 10-seconds before going solid, at which time the lead unit Y1 cooling output turns on. If the outdoor temperature and humidity conditions are below the setpoint of the economizer control the lead unit economizer will operate instead of the compressor. If outdoor conditions are not acceptable for free cooling the compressor will automatically operate instead of the economizer.

2nd cooling setpoint is 4F (default setting, user selectable 2-6F) warmer than Stage 1. On a call for 2nd Stage cooling the blower of the lag unit is turned on (if not already on – See Blower Operation), and the Stage 2 LED will blink for 10-seconds before going solid, at which time the lag unit Y1 cooling output turns on. If

the outdoor temperature and humidity conditions are below the setpoint of the economizer control the lag unit economizer will operate instead of the compressor. If outdoor conditions are not acceptable for free cooling the compressor will automatically operate instead of the economizer.

3rd cooling setpoint is 2F (default setting, user selectable 2-3F) warmer than Stage 2. On a call for 3rd Stage cooling the lead unit economizer will continue to operate as long as outdoor conditions are acceptable, and the compressor will operate.

4th cooling setpoint is 2F (default setting, user selectable 2-3F) warmer than Stage 3. On a call for 4th Stage cooling the lag unit economizer will continue to operate as long as outdoor conditions are acceptable, and the compressor will operate.

5. 2-Stage Compressor Units with EIFM Economizers

1st stage cooling setpoint is the setting (SP) input into the controller. Factory default is 77F (25C). On a call for cooling the blower of the lead unit will come on immediately (if not already on – See Blower Operation), and the Stage 1 LED will blink for 10-seconds before going solid, at which time the lead unit Y1 cooling output turns on. If the outdoor temperature and humidity conditions are below the setpoint of the economizer control the lead unit economizer will operate instead of the compressor. If outdoor conditions are not acceptable for free cooling the compressor will automatically operate on compressor Stage 1 partial capacity instead of the economizer.

2nd cooling setpoint is 4F (default setting, user selectable 2-6F) warmer than Stage 1. On a call for 2nd Stage cooling the blower of the lag unit is turned on (if not already on – See Blower Operation), and the Stage 2 LED will blink for 10-seconds before going solid, at which time the lag unit Y1 cooling output turns on. If the outdoor temperature and humidity conditions are below the setpoint of the economizer control the lag unit economizer will operate instead of the compressor. If outdoor conditions are not acceptable for free cooling the compressor will automatically operate on compressor Stage 1 partial capacity instead of the economizer.

3rd cooling setpoint is 2F (default setting, user selectable 2-3F) warmer than Stage 2. On a call for 3rd Stage cooling the lead unit economizer will close and the compressor will operate on full capacity compressor Stage 2.

4th cooling setpoint is 2F (default setting, user selectable 2-3F) warmer than Stage 3. On a call for 4th Stage cooling the lag unit economizer will close and the compressor will operate on full capacity compressor Stage 2.

6. 2-Stage Compressor Units with ECONWM* or WECOP Economizers (See Note A)

1st stage cooling setpoint is the setting (SP) input into the controller. Factory default is 77F (25C). On a call for cooling the blower of the lead unit will come on immediately (if not already on – See Blower Operation), and the Stage 1 LED will blink for 10-seconds before going solid, at which time the lead unit Y1 cooling output turns on. If the outdoor temperature and humidity conditions are below the setpoint of the economizer control the lead unit economizer will operate instead of the compressor. If outdoor conditions are not acceptable for free cooling the compressor will automatically operate on compressor Stage 1 partial capacity instead of the economizer.

2nd cooling setpoint is 4F (default setting, user selectable 2-6F) warmer than Stage 1. On a call for 2nd Stage cooling the blower of the lag unit is turned on (if not already on – See Blower Operation), and the Stage 2 LED will blink for 10-seconds before going solid, at which time the lag unit Y1 cooling output turns on. If the outdoor temperature and humidity conditions are below the setpoint of the economizer control the lag unit economizer will operate instead of the compressor. If outdoor conditions are not acceptable for free cooling the compressor will automatically operate on compressor Stage 1 partial capacity instead of the economizer.

3rd cooling setpoint is 2F (default setting, user selectable 2-3F) warmer than Stage 2. On a call for 3rd Stage cooling the lead unit economizer will continue to operate as long as outdoor conditions are acceptable, and the compressor will operate on compressor Stage 1 partial capacity. If outdoor conditions are not acceptable for free cooling the lead unit compressor will automatically be operating on compressor Stage 1 partial capacity and will go to Stage 2 full capacity operation.

4th cooling setpoint is 2F (default setting, user selectable 2-3F) warmer than Stage 3. On a call for 4th Stage cooling the lag unit economizer will continue to operate as long as outdoor conditions are acceptable, and the compressor will operate on compressor Stage 1 partial capacity. If outdoor conditions are not acceptable for free cooling the lag unit compressor will automatically be operating on compressor Stage 1 partial capacity and will go to Stage 2 full capacity operation.

COOLING OPERATING SEQUENCES FOR NON-ALTERNATING LEAD/LEAD/LAG/LAG CONFIGURATION

***NOTE:** Heat pumps cannot be operated in Non-Alternating Lead/Lead/Lag/Lag sequence. Selecting Heat Pump = Yes will override a Non-Alternating selection and force system to Alternating Lead/Lag/Lead/Lag sequence.*

1. 2-Stage Compressor Units No Economizer

1st stage cooling setpoint is the setting (SP) input into the controller. Factory default is 77F (25C). On a call for cooling the blower of the lead unit will come on immediately (if not already on – See Blower Operation), and the Stage 1 LED will blink for 10-seconds before going solid, at which time the lead unit compressor will start in compressor Stage 1 partial capacity operation.

2nd cooling setpoint is 4F (default setting, user selectable 2-6F) warmer than Stage 1, at which time the lead unit compressor will switch to compressor Stage 2 full capacity.

3rd cooling setpoint is 2F (default setting, user selectable 2-3F) warmer than Stage 2. On a call for 3rd Stage cooling the blower of the lag unit will come on immediately (if not already on – See Blower Operation), and Stage 3 LED will blink for 10-seconds before going solid, and then the lag unit compressor will start in compressor Stage 1 partial capacity.

4th cooling setpoint is 2F (default setting, user selectable 2-3F) warmer than Stage 3. On a call for 4th Stage cooling the Stage 4 LED comes on solid (no delay), and the lag unit compressor will switch to compressor Stage 2 full capacity operation.

2. 1-Stage Compressor Units with EIFM Economizers

1st stage cooling setpoint is the setting (SP) input into the controller. Factory default is 77F (25C). On a call for cooling the blower of the lead unit will come on immediately (if not already on – See Blower Operation), and the Stage 1 LED will blink for 10-seconds before going solid, at which time the lead unit Y1 cooling output turns on. If the outdoor temperature and humidity conditions are below the setpoint of the economizer control the lead unit economizer will operate instead of the compressor. If outdoor conditions are not acceptable for free cooling the compressor will automatically operate instead of the economizer.

2nd cooling setpoint is 4F (default setting, user selectable 2-6F) warmer than Stage 1. On a call for 2nd Stage cooling the lead unit Y2 cooling output turns on. The lead unit economizer will close and the compressor will operate. If the compressor is already running from 1st stage cooling call due to outdoor conditions being outside of free cooling range no action occurs at 2nd stage setpoint.

3rd cooling setpoint is 2F (default setting, user selectable 2-3F) warmer than Stage 2. On a call for 3rd Stage cooling the blower of the lag unit is turned on (if not already on – See Blower Operation), and the Stage 3 LED will blink for 10-seconds before going solid, and the lag unit economizer will operate if the outdoor temperature and humidity conditions are below the setpoint of the economizer control. If outdoor conditions are not acceptable for free cooling

the compressor will automatically operate instead of the economizer.

4th cooling setpoint is 2F (default setting, user selectable 2-3F) warmer than Stage 3. On a call for 4th Stage cooling the lag unit economizer will close and the compressor will operate. If the compressor is already running from 3rd stage cooling call due to outdoor conditions being outside of free cooling range no action occurs at 2nd stage setpoint.

3. 1-Stage Compressor Units with ECONWM* or WECOP Economizers (See Note A)

1st stage cooling setpoint is the setting (SP) input into the controller. Factory default is 77F (25C). On a call for cooling the blower of the lead unit will come on immediately (if not already on – See Blower Operation), and the Stage 1 LED will blink for 10-seconds before going solid, at which time the lead unit Y1 cooling output turns on. If the outdoor temperature and humidity conditions are below the setpoint of the economizer control the lead unit economizer will operate instead of the compressor. If outdoor conditions are not acceptable for free cooling the compressor will automatically operate instead of the economizer.

2nd cooling setpoint is 4F (default setting, user selectable 2-6F) warmer than Stage 1. On a call for 2nd stage cooling the lead unit Y2 cooling output turns on. If the outdoor temperature and humidity conditions are below the setpoint of the economizer control the lead unit economizer will continue to operate, and the compressor will operate. If the compressor is already operating on 1st stage cooling because outside free cooling range no action occurs at 2nd cooling setpoint.

3rd cooling setpoint is 2F (default setting, user selectable 2-3F) warmer than Stage 2. On a call for 3rd Stage cooling the blower of the lag unit will come on immediately (if not already on – See Blower Operation), and the Stage 3 LED will blink for 10-seconds before going solid, at which time the lag unit Y1 cooling output turns on. The lag unit economizer will operate if the outdoor temperature and humidity conditions are below the setpoint of the economizer control. If outdoor conditions are not acceptable for free cooling the compressor will automatically operate instead of the economizer.

4th cooling setpoint is 2F (default setting, user selectable 2-3F) warmer than Stage 3. On a call for 4th Stage cooling the lag unit Y2 cooling output turns on activating the lag unit compressor. If the outdoor temperature and humidity conditions are below the setpoint of the economizer control the lag unit economizer will continue to operate. If the compressor is already operating on 3rd stage cooling because outside free cooling range no action occurs at 4th cooling setpoint.

4. 2-Stage Compressor Units with EIFM Economizers

1st stage cooling setpoint is the setting (SP) input into the controller. Factory default is 77F (25C). On a call for cooling the blower of the lead unit will come on immediately (if not already on – See Blower Operation), and the Stage 1 LED will blink for 10-seconds before going solid, at which time the lead unit Y1 cooling output turns on. If the outdoor temperature and humidity conditions are below the setpoint of the economizer control the lead unit economizer will operate instead of the compressor. If outdoor conditions are not acceptable for free cooling the compressor will automatically operate on compressor Stage 1 partial capacity instead of the economizer.

2nd cooling setpoint is 4F (default setting, user selectable 2-6F) warmer than Stage 1. On a call for 2nd stage cooling the lead unit Y2 cooling output turns on, at which time the lead unit compressor will operate on compressor Stage 2 full capacity. If the compressor is already operating on Stage 1 partial capacity because outside free cooling range the compressor will switch to compressor Stage 2 full capacity.

3rd cooling setpoint is 2F (default setting, user selectable 2-3F) warmer than Stage 2. On a call for 3rd Stage cooling the blower of the lag unit will come on immediately (if not already on – See Blower Operation), and the Stage 3 LED will blink for 10-seconds before going solid. The lag unit economizer will operate if the outdoor temperature and humidity conditions are below the setpoint of the economizer control. If outdoor conditions are not acceptable for free cooling the compressor will automatically operate on compressor Stage 1 partial capacity instead of the economizer.

4th cooling setpoint is 2F (default setting, user selectable 2-3F) warmer than Stage 3. On a call for 4th Stage cooling the lag unit Y2 cooling output turns on, at which time the lag unit compressor will operate on compressor Stage 2 full capacity. If the compressor is already operating on Stage 1 partial capacity because outside free cooling range the compressor will switch to compressor Stage 2 full capacity.

5. 2-Stage Compressor Units with ECONWM* or WECOP Economizers (See Note A)

1st stage cooling setpoint is the setting (SP) input into the controller. Factory default is 77F (25C). On a call for cooling the blower of the lead unit will come on immediately (if not already on – See Blower Operation), and the Stage 1 LED will blink for 10-seconds before going solid, at which time the lead unit Y1 cooling output turns on. If the outdoor temperature and humidity conditions are below the setpoint of the economizer control the lead unit economizer will operate instead of the compressor. If outdoor conditions are not acceptable for free cooling the compressor will

automatically operate on compressor Stage 1 partial capacity instead of the economizer.

2nd cooling setpoint is 4F (default setting, user selectable 2-6F) warmer than Stage 1. On a call for 2nd stage cooling the lead unit Y2 cooling output turns on. If the outdoor temperature and humidity conditions are below the setpoint of the economizer control the lead unit economizer will continue to operate, and the compressor will operate on compressor Stage 1 partial capacity. If the compressor is already operating on Stage 1 partial capacity because outside free cooling range the compressor will switch to compressor Stage 2 full capacity.

3rd cooling setpoint is 2F (default setting, user selectable 2-3F) warmer than Stage 2. On a call for 3rd Stage cooling the blower of the lag unit will come on immediately (if not already on – See Blower Operation), and the Stage 3 LED will blink for 10-seconds before going solid, at which time the lag unit Y1 cooling output turns on. The lag unit economizer will operate if the outdoor temperature and humidity conditions are below the setpoint of the economizer control. If outdoor conditions are not acceptable for free cooling the compressor will automatically operate on compressor Stage 1 partial capacity instead of the economizer.

4th cooling setpoint is 2F (default setting, user selectable 2-3F) warmer than Stage 3. On a call for 4th Stage cooling the lag unit Y2 cooling output turns on activating the compressor. If the outdoor temperature and humidity conditions are below the setpoint of the economizer control the lag unit economizer will continue to operate, and the compressor will operate on compressor Stage 2 full capacity. If the compressor is already operating on Stage 1 partial capacity because outside free cooling range the compressor will switch to compressor Stage 2 full capacity.

NOTE A: Economizers in ECONWM* or WECOP Series are available with either “T” temperature only outdoor sensor or “E” enthalpy (temperature and humidity) outdoor sensor. The “T” versions will have a fixed (but selectable) outdoor temperature decision whereas on the “E” versions the outdoor temperature decision will float based on outdoor humidity and the selected Enthalpy curve in the economizer control module.

HEATING SEQUENCE OF OPERATION

NOTE: All heating sequences for air conditioners with electric heat or heat pumps will automatically operate in Alternating Lead/Lag/Lead/Lag sequence even if controller is set to Non-Alternating for cooling with or without economizers.

1. Air Conditioners with Electric Heat

1st stage heating setpoint is the dead-band (db) below the 1st stage cooling setpoint (the SP entered into the

program). The dead-band is adjustable from 2-40F, and factory default is 17F.

2nd stage heating setpoint will operate at same inter-stage differential as set for cooling mode.

2. Heat Pumps with Electric Heat

When the MC4002 controller is configured for heat pump installations the 2nd-stage (Y2) outputs for both units 1 and 2 are redefined and used to control the reversing valves, and which are energized in heating mode.

1st stage heating setpoint is the dead-band (db) below the 1st stage cooling setpoint (the SP entered into the program). The dead-band is adjustable from 2-40F, and factory default is 17F.

1st-stage heating consists of lead unit blower coming on (if not already on – See Blower Operation), and reversing valve being energized. The Stage 1 heating LED will blink for 10-seconds, at which time the compressor turns on.

2nd heating setpoint is 4F (default setting, user selectable 2-6F) cooler than Stage 1. On a call for 2nd Stage heating the blower of the lag unit is turned on (if not already on – See Blower Operation), the reversing valve is energized, and the Stage 2 LED will blink for 10-seconds before going solid, at which time the compressor will start.

3rd-stage heating will be the electric heater, if so equipped, in the lead unit. Stage 3 heating LED comes on solid with no blinking.

4th-stage heating will be the electric heater, if so equipped, in the lag unit. Stage 4 heating LED comes on solid with no blinking.

SPECIFICATIONS FOR OPTIONAL REMOTE COMMUNICATION BOARD

CB5000 Series Communication Board

NOTE: If the communication board (Bard CB5000 Series) was not originally factory installed, it can be field installed at anytime. It allows remote access via Ethernet, depending upon level of authority assigned, to all functions of the controller system the same as if one was in the building where the controller system is physically installed.

Required input connections to the CB5000 Series (these are all internal connections from either the alarm board or main controller board):

1. Fire/smoke connection from MC4002 main controller board.
2. Refrigerant lockout inputs.
3. If economizers are used, an additional 24V signal wire is required from each air conditioner to the controller system.

- Communication cable from CB5000 Series plugs into the Ethernet connection on main MC4002 controller board.

CB5000 Series Communication Board

Reset button to return to default controller settings. Also use to reset user name to "Admin" and password to "Bard". See page 17.

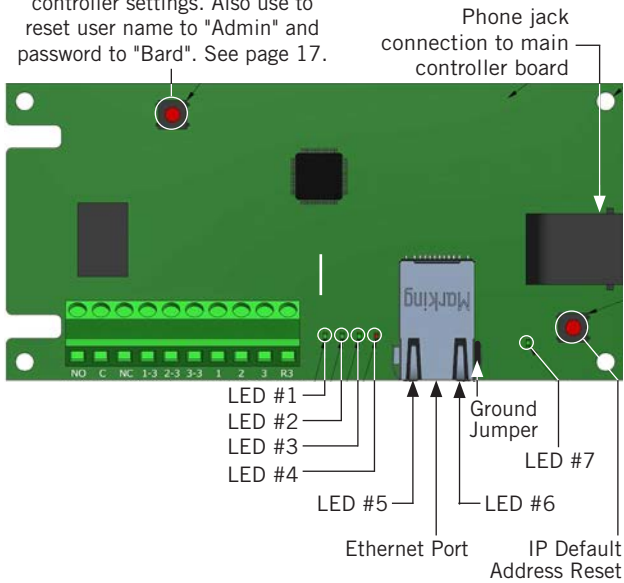

LED Light Diagnostics			
Light	Description	Normal Operation	Notes
LED #1	Power	Solid Green	If off, no power to board.
LED #2	Not Used	Not Used	Used for debugging only.
LED #3	Serial Communication	Blinking Red	If solid, reset controller power.
LED #4	Not Used	Not Used	Used for debugging only.
LED #5	Ethernet Link	Solid Green	If not on, ethernet is not connected.
LED #6	Ethernet Activity	Blinking Green/Yellow	If not on, board is not communicating.
LED #7	Speed	Solid Green or Off	100MB/S if on, 10MB/S if off.

Operating System

No special software is required to access the system. The CB5000 Series has a default address, simply follow these instructions.

To Access the System

IMPORTANT: The CB5000 Series is shipped with the Ethernet shield ungrounded. Before moving jumper to ground the shield, check for voltage between the ground on the MC/MV and the shield of the Ethernet cable that will be plugged into the Ethernet port on the

CB5000 Series board. This cable must be connected to the network before testing for voltage. If voltage exists, do not move the jumper as the CB5000 Series will be damaged. If no voltage exists, ground the shield by moving the ground jumper on the right side of the Ethernet port to jumper both pins together.

- Connect CAT 5 or CAT 6 Ethernet cable from computer to Ethernet port on the CB5000 Series.
- Change the computer's IP address as shown below to gain initial access to the CB5000 Series.

NOTE 1: Record the computer's current IP settings BEFORE making any changes. Reset back to these original settings once an IP address to the CB5000 Series has been assigned.

For XP or Windows 2000:

- Open Control Panel, double click Network Connections.
- Double click Local Area Connection on the General tab and select Properties.
- Using the General tab, scroll to Internet Protocol (TCP/IP).
- Highlight Internet Protocol (TCP/IP) and select Properties.
- Change the addresses as follows:
 IP address: 192.168.1.50
 Subnet mask: 255.255.255.0
 Default gateway: 192.168.1.1
 Preferred DNS server: 192.168.1.10
 Alternate DNS server: 192.168.1.11
- Click OK and close all windows.
- Start the browser, enter the CB5000 Series default IP address **192.168.1.67** and hit Enter.
- The MC4000 log in page should appear.

For Vista, Windows 7 or Windows 10:

- Open Control Panel, click Network & Internet.
- Click Network & Sharing Center.
- Click Local Area Connection or Ethernet link.
- Click Properties.
- Highlight Internet Protocol Version 4 (TCP/IPV4) and select Properties.
- Change the addresses as follows:
 IP address: 192.168.1.50
 Subnet mask: 255.255.255.0
 Default gateway: 192.168.1.1
 Preferred DNS server: 192.168.1.10
 Alternate DNS server: 192.168.1.11
- Click OK and close all windows.

8. Start the browser, enter the CB5000 Series default IP address **192.168.1.67** and hit Enter.
9. The MC4000 log in page should appear.

Log In Page

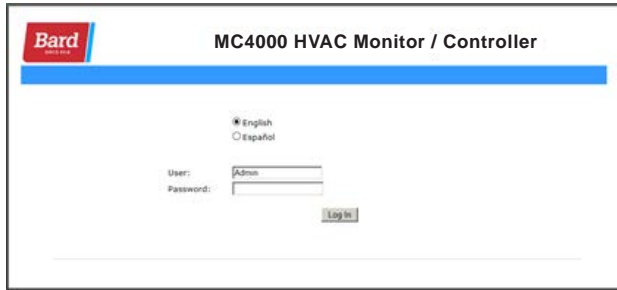

1. Type "Admin" for user name and "Bard" for password. These are case sensitive. Hit "Log In". The System Status Page will appear.

NOTE: Pressing the controller reset button shown in the **CB5000 Series Communication Board** image will reset the user and password to "Admin" and "Bard", respectively. This default password can only be used to first establish communication with the controller. Upon using this password to login, the controller will navigate to users screen and prompt user to input new username and password. The password cannot be set to the default.

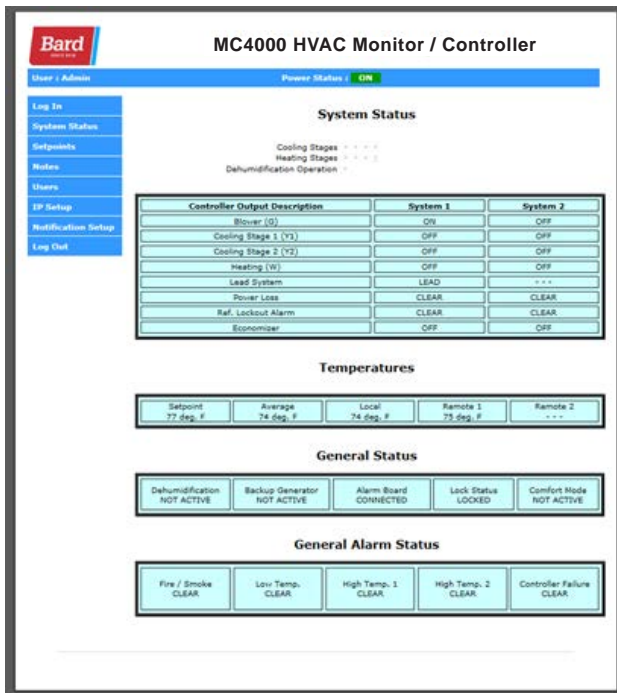

System Status Page

The System Status Page shows:

1. The overall HVAC status of:

- a. Active cooling or heating stages or dehumidification mode (requires humidity sensor)
- b. Active controller outputs (blower, cooling Stage 1 or 2, heating) to each air conditioner
- c. Which unit is the Lead unit
- d. Power loss or refrigerant lockout for each air conditioner
- e. If economizers are used if on or off (**NOTE:** Older style EIFM economizers require a simple relay kit for this feature to work, Bard P/N 8620-221)

2. General status of:

- a. Dehumidification Active or not
- b. Backup Generator Active or not (if tied to generator run controls to inhibit lag unit operation during generator run)
- c. Alarm board connected or not
- d. Controller system Locked or Unlocked
- e. Comfort mode Active or not

3. Temperatures:

- a. Average temperature (if more than one sensor used, if not will read same as Local sensor)
- b. Local sensor at controller
- c. Remote 1 or Remote 2 if connected

4. General Alarm Status:

- a. Fire/Smoke, Clear or Alarm
- b. Low Temp, Clear or Alarm
- c. High Temp #1, Clear or Alarm
- d. High Temp #2, Clear or Alarm
- e. Controller Failure, Clear or Alarm

Click the "IP Setup" button on the left side of the page.

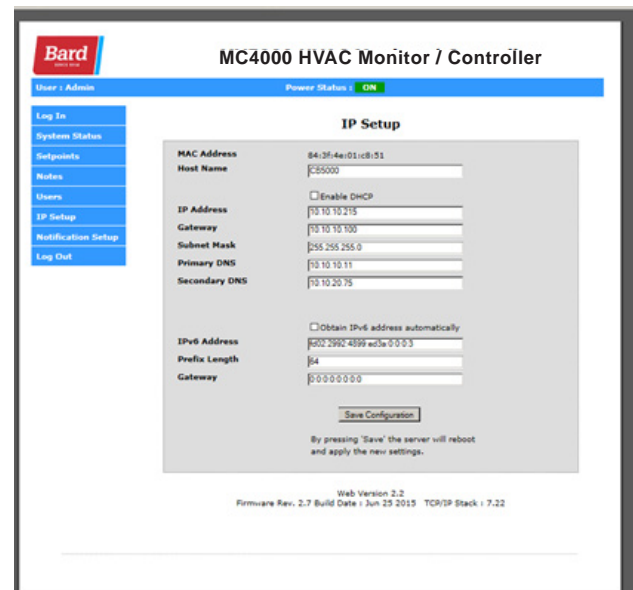

NOTE: If the remote user is on a different subnet than the CB5000 Series, it is recommended that Static IP Addressing be used rather than DHCP.

If Network Uses Static IP Addressing

1. Enter the correct address information provided by the IT department and click the “Save Config” button.
2. The assumption is that the new IP address has already been configured into the network to get through any firewall(s).
3. Disconnect the Ethernet cable from the computer and plug into the router.
4. Change the computer system's IP address back to their previous settings recorded in **NOTE 1**.
5. Type the new IP address into the browser and make any changes to the MC4000 system before logging out.

If Network Uses DHCP

1. Check the “Enable DHCP” box.
2. Click “Save Config” box. It will take several seconds before receiving a message that it is now offline. At this point the unit is now running in DHCP mode.
3. Change the computer system's IP address back to their previous settings from **NOTE 1** on page 16.
4. Type CB5000 Series in the browser's URL address bar to access the CB5000 Series.

NOTE 2: To get back to the CB5000 Series default IP setting, simply hold the reset button next to the Ethernet jack for 5+ seconds, then release.

Connect to Network

1. After initial set up using laptop computer, disconnect computer cable from the Ethernet port and connect the CAT 5 or CAT 6 network cable.
2. Remote access is now available using the assigned IP address and valid user name and password (case sensitive).

Setpoints Page

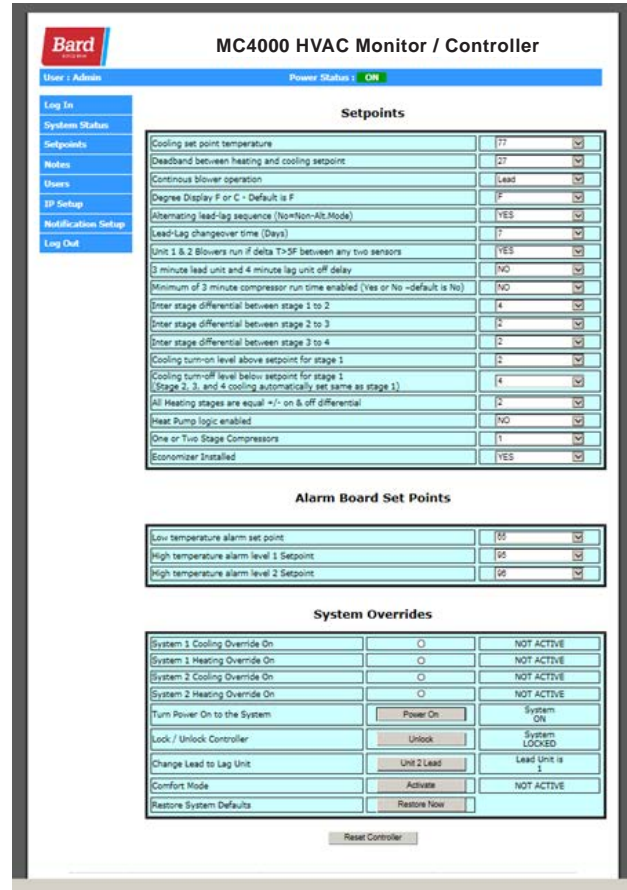

NOTE: “Read” level authority can view this screen but cannot make any changes. “Admin” and “Write” authority can make changes.

1. General Setpoints
 - a. On initial installation and start up, all selectable characteristics are set to factory default settings.
 - b. Each of these points has a drop-down menu for ease of use.
2. Alarm Board Setpoints
 - a. Low temperature alarm setpoint
 - b. High temperature alarm #1 setpoint
 - c. High temperature alarm #2 setpoint
3. System Overrides
 - a. System 1 Cooling Override
 - b. System 1 Heating Override
 - c. System 2 Cooling Override
 - d. System 2 Heating Override
 - e. Turn Power On to the System (**NOTE:** Cannot remotely turn the controller system Off)
 - f. Lock/Unlock Controller
 - g. Advance Lead to Lag Unit

- h. Comfort Mode
- i. Restore System Defaults
- j. Reset Controller. There are built-in routines to prevent the controller system from getting “locked up”, but this also allows a manual remote reset as a backup before having a service call to the site.

Notes Page

This screen provides a place to leave notes about the site for the technician or engineer.

Users Page

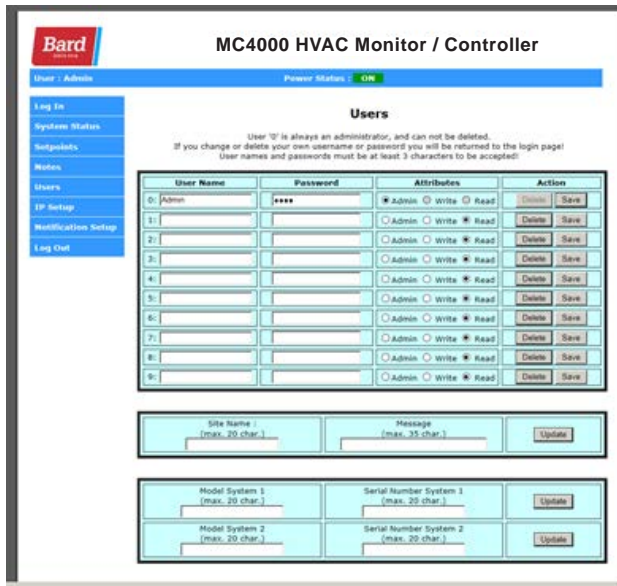

1. The designated Admin person can assign up to nine additional users and set up as Admin, Write or Read authority.
2. User name and password must be assigned. Each must be at least three characters long and are case sensitive.
3. Only “Admin” can add, change or delete users and has access to all controller pages.
4. “Write” can make changes to the controller settings and operating characteristics and has access to only Log In, System Status, Setpoints and Log Out pages.
5. “Read” can only view Status and Setpoints pages and cannot make any changes.

Notification Setup Page

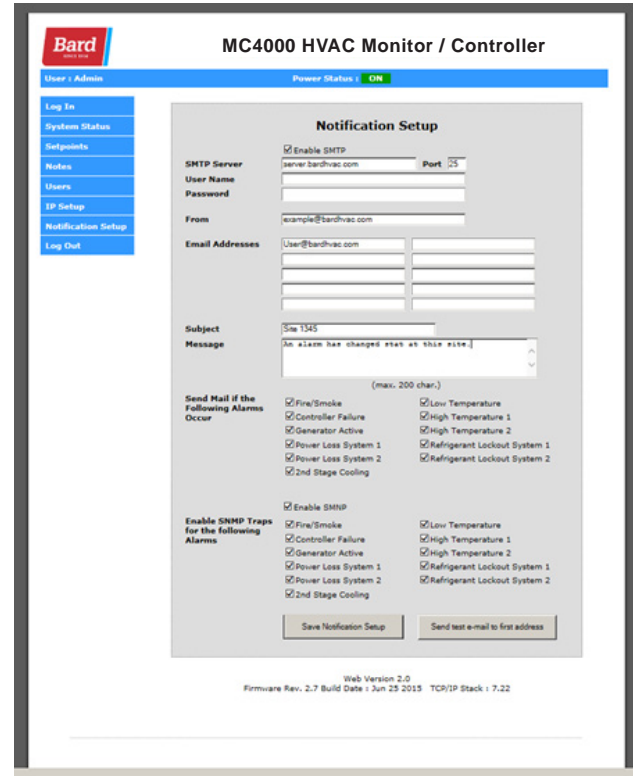

The notification setup page is used to determine which alarms are remotely communicated to the offsite monitoring systems. The CB5000 Series has the capability to communicate using SNMP v2 protocol as well as email notifications for specific events.

Email Notifications

To enable email notifications, ensure that the check box is checked next to “Enable SMTP” and “Enable SNMP” even if traps are not going to be used. After the feature is enabled, the controller needs to be configured with the SMTP Server name, the port, username and password. This information will need to be provided by the network administrator from where the controller will be installed.

SMTP Server – This is the IP address of the SMTP Server.

Port – The configured port for the SMTP Server.

User Name – The username used to authenticate with the server.

Password – The password used to authenticate with the server.

Once the server settings have been entered, the destination for the notification can be set and the message customized to include relevant information.

From – Enter the email address that the email notification should come from.

Email Addresses – Add up to 10 valid email addresses that will receive the email notification.

Subject – Customize the subject line of the email notification.

Message – Add a custom message to the notification to include relevant information regarding the equipment or building the equipment is installed on.

Send Mail if the Following Alarms Occur – Select the alarms that will generate an email notification.

Once all of the information above has been set, be sure to check that the email notifications are working by pressing the button “Send test e-mail to first address”. As the button indicates, this test email will only be sent to the email address in the first box. When the button is pressed the message will contain “MC4001 Test Message!” When the message is generated by an event it will contain the status of all alarms the controller offers.

Example:

- ALARM : Fire/Smoke
- CLEAR : Controller Failure
- CLEAR : 2nd Stage Cooling
- CLEAR : Low Temperature
- CLEAR : High Temperature 1
- CLEAR : High Temperature 2
- CLEAR : Power Loss System 1
- CLEAR : Power Loss System 2
- CLEAR : Refrigerant Lockout System 1
- CLEAR : Refrigerant Lockout System 2
- CLEAR : Generator Active

SNMP

Enable the Traps

Ensure that the check box is checked next to “Enable SNMP”. After enabling SNMP, select which events will

generate traps by checking the box next each item that should generate a trap.

Network Traffic Limitation

The CB5000 Series has limitations regarding how fast the controller can be polled for data. It is recommended that polling be limited to no faster than once per minute. In addition to this, it is also recommended that the network administrator for the network in which the device will be connected is contacted regarding a network inventory scan. If the network has a scheduled network scan, the IP address assigned to the controller should be added to an exclusion list. The network scan, in addition to the scheduled polling, can cause the communication board to lock up and require a power cycle before communication can be re-established.

Set the Trap Destination

The configuration of the controller through SNMP will require the MIB file and an MIB browser to set the trap destination. The MIB file for the SNMP configuration on the controller is available at <http://bardhvac.com/software-download>. Once the file has been downloaded, be sure to unzip the file before opening the MIB file in an MIB browser. Enter the IP address of the controller into the MIB browser and, with the MIB loaded, navigate through the MIB tree to Setup>ipv4TrapTable > ipv4TrapEntry and open the IPv4 in Table View as shown in **Set Trap Destination**.

NOTE: *ipv6TrapTable is configured to operate with IPv6.*

The ipv4TrapEnabled needs to be set to Yes and ipv4TrapReceiverIPAddress need to be set to the destination IP address for the traps. This can be configured for up to four destinations by setting these two settings for each row within this table (see **ipv4 Trap Table**).

ipv4 Trap Table

	ipv4TrapRecei...	ipv4TrapEnabled	ipv4TrapRecei...	ipv4TrapCom...	Index Value
1	0	yes	192.168.0.25		0
2	1	no	0.0.0.0		1
3	2	no	0.0.0.0		2
4	3	no	0.0.0.0		3

SNMP SET

OID: .1.3.6.1.4.1.44433.1.1.0.1.1.3.1

Data Type: IpAddress

Value: IPv4 or IPv6 address. IPv6 Format: 2x:2x:2x:2x:2x:2x:2x - e.g. 2001:0db8:85a3:0000:0000:8a2e

Buttons: Ok, Cancel

Set Trap Destination

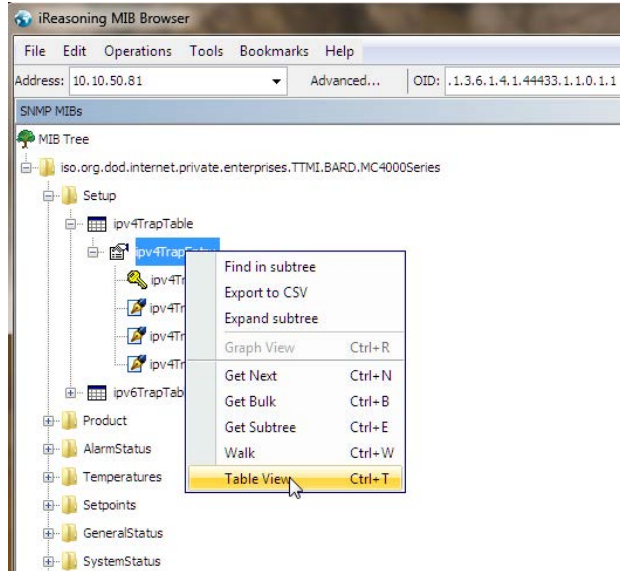

To adjust a cell within this table, highlight the cell to be changed and press the “SNMP SET” button. A popup will appear and the value can be changed.

MIB File Structure Contents

The following commands are used with the MIB browser to access information.

Get – Used to retrieve information from a single variable. Used on product, alarmstatus, temperatures, setpoints, generalstatus, systemstatus and operationstatus folders.

Get Next – Used to retrieve the information from the next variable in the MIB file. Used on product, alarmstatus, temperatures, setpoints, generalstatus, systemstatus and operation status folders.

Get Subtree – Used to retrieve the information from a single folder or multiple folders. Used on product, alarmstatus, temperatures, setpoints, generalstatus, systemstatus, and operation status folders. This can also be used to poll all data by selecting “iso.org.dod.internet.private.enterprises.TTMI.BARD.MC4000Series” and using get subtree.

Table View – Used to view the information in the setup folder. Displays the table to configure trap receiver settings.

Folder	SNMP Points List	Description
Setup	ipv4TrapReceiverNumber	Used to indicate the row of the table and is not configurable
Setup	ipv4TrapEnabled	Used to enable up to 4 IPv4 trap recipients
Setup	ipv4TrapReceiverIPAddress	Used to set the IP address destination for each IPv4 recipients
Setup	ipv4TrapCommunity	Used to set the community for each IPv4 recipient
Setup	ipv6TrapReceiverNumber	Used to indicate the row of the table and is not configurable
Setup	ipv6TrapEnabled	Used to enable up to 4 ipv6 trap recipients
Setup	ipv6TrapReceiverIPAddress	Used to set the IP address destination for each ipv6 recipients
Setup	ipv6TrapCommunity	Used to set the community for each ipv6 recipient
Product	Site	The name of the site where the equipment is located
Product	Name	The product name
Product	Version	The product version
Product	Date	The product date
Product	ModelSystem1	The model number of unit 1
Product	SerialSystem1	The serial number of unit 1
Product	ModelSystem2	The model number of unit 2
Product	SerialSystem2	The serial number of unit 2
AlarmStatus	FireSmokeShutdown	Fire Smoke Shutdown Alarm
AlarmStatus	ControllerFailure	Controller Failure Alarm
AlarmStatus	SecondStageCooling	Second stage cooling alarm
AlarmStatus	LowTempAlarm	Low temperature alarm
AlarmStatus	HighTempAlarm1	High temperature 1 alarm

Continued on page 22

Folder	SNMP Points List	Description
AlarmStatus	HighTempAlarm2	High temperature 2 alarm
AlarmStatus	PowerLossUnit1	Power loss alarm for unit 1
AlarmStatus	PowerLossUnit2	Power loss alarm for unit 2
AlarmStatus	Unit1Lockout	Unit 1 lockout alarm
AlarmStatus	Unit2Lockout	Unit 2 lockout alarm
Temperatures	LocalRoomTemp	Local room temperature
Temperatures	RemoteSensor1Temp	Remote sensor 1 temperature
Temperatures	RemotesSensor2Temp	Remote sensor 2 temperature
Setpoints	CoolingSetpoint	Cooling Setpoint
Setpoints	HeatingSetpoint	Heating Setpoint
Setpoints	HighTempAlarm1Setpoint	High Temperature alarm 1 setpoint
Setpoints	HighTempAlarm2Setpoint	High temperature 2 alarm setpoint
Setpoints	LowTempAlarmSetpoint	Low temperature alarm setpoint
GeneralStatus	GeneratorRunning	Generator run status
GeneralStatus	AlarmBoardConnected	Alarm board connected status
GeneralStatus	ComfortMode	Comfort mode status
GeneralStatus	ControllerLocked	Controller Locked Status
SystemStatus	LeadUnitHVAC1	Lead unit is HVAC 1
SystemStatus	LeadUnitHVAC2	Lead unit is HVAC 2
SystemStatus	Unit1Fan	Unit 1 fan status
SystemStatus	Unit2Fan	Unit 2 fan status
Operation Status	CoolingStage1	Stage 1 cooling status
Operation Status	CoolingStage2	Stage 2 cooling status
Operation Status	CoolingStage3	Stage 3 cooling status
Operation Status	CoolingStage4	Stage 4 cooling status
Operation Status	HeatingStage1	Stage 1 heating status
Operation Status	HeatingStage2	Stage 2 heating status
Operation Status	HeatingStage3	Stage 3 heating status
Operation Status	HeatingStage4	Stage 4 heating status
Operation Status	DehumidificationActive	Dehumidificaiton status
Events	trapFireSmokeShutdown	Fire smoke shutdown trap
Events	trapControllerFailure	Controller failure trap
Events	trapHighTempAlarm1	High temperature alarm 1 trap
Events	trapHighTempAlarm2	High temperature alarm 2 trap
Events	trapPowerLossUnit1	Power loss alarm for unit 1 trap
Events	trapPowerLossUnit2	Power loss alarm for unit 2 trap
Events	trapUnit1Lockout	Unit 1 Lockout alarm trap
Events	trapUnit2Lockout	Unit 2 lockout alarm trap
Events	trapGeneratorRunning	Generator running trap

Log Out Button

1. Clicking this button will automatically log off the controller remote access.
2. To log back in will require entering assigned IP address into the browser and entering valid user name and password.

CONTROLLER WIRING

The MC4002 can be used for controlling two (2) air conditioners with or without economizers. It can also be configured for two (2) heat pumps without economizers. Units with economizers will connect differently than units without economizers; therefore, it is important to use the correct connection diagram.

There are older style EIFM economizers and newer style ECONWM* or WECOP economizers that the MC4002 controller system can work with, and also an option for a remote Ethernet communication board. Therefore, it is important to select the correct low voltage hook-up diagram. See Controller Connection Diagrams beginning on page 24.

SECURITY (LOCKING) FEATURE

The MC4002 controller can be locked such that unauthorized persons cannot make any changes to temperature setpoints or any other selectable parameters of the controller system.

The ON/OFF and Comfort buttons remain fully active for their normal intent. The Advance/Change/Save button remains active for the Advance feature only, which allows the position of the lead and lag air conditioners to be swapped (reversed). The Program button remains partially active—allowing the review of temperature sensor(s) actual reading of temperature, and the current settings/choices that have been chosen. However, no changes can be made when the controller is locked, and if the change button is pressed when in the Program mode, the display will come up showing “Locd” instead of flashing the selectable choices for that parameter. The default (DEF) reset capability is also disabled when the controller is in locked mode.

Locking and Unlocking the MC4002 Controller:

1. Locking the controller requires using 3 buttons while the controller is in the normal operating (run) mode.
2. Press and hold the Advance/Change/Save button and the Up and Down arrow buttons simultaneously for 20 seconds until the display shows “Locd”.
3. To unlock the controller, press the Change, Up and Down arrow buttons simultaneously for 20 seconds until the display reads “uLoc”.

GENERATOR RUN FEATURE

If desired, the MC4002 controller can be signaled from a standby generator system to lockout (disable operation) of the lag air conditioning system. This is sometimes mandated if the generator size is not sufficient to handle the building load (amperage) and that of both air conditioning systems.

A normally closed (NC) dry contact as part of generator controls is required. These contacts must open when the generator is started, and such action will signal the MC4002 controller to this condition and disable lag air conditioner run function.

A wire jumper is factory installed across the G1 and G2 terminals or main controller board. To utilize the generator run feature, remove the jumper from G1 and G2, and connect the generator normally closed (NC) contacts that will open-on-run generator condition to the G1 and G2 terminals.

BACKUP DC POWER CONNECTION

There are input connections available for -24VDC or -48VDC (-20 to -56V) backup power connection. Making this connection will maintain microprocessor operation, front panel display, LED signaling, alarm relay and communication board (CB500*) operation during periods of commercial power outages and when no standby generator is available. This circuit is protected by a replaceable .5A (500mA) circuit breaker.

IMPORTANT: *The shelter DC battery power must be connected to the controller and wired as shown in controller wiring diagrams.*

The backup DC power connection is polarity sensitive. If polarity is reversed, the controller will not function on backup power, no display and no alarm functions will be evident.

CONTROLLER CONNECTIONS DIAGRAMS

TABLE 1
Controller Connections Diagrams Index

Diagram #	Controller Connection Diagram	Page #
1	1-Stage (W**AB/W**LB/W**AC Series) Air Conditioners – No Economizers	25
2	1-Stage (W**AB/W**LB/W**AC Series) Air Conditioners – No Economizers with Alarm Board & CB5000 Series Communication Board	26
3	1-Stage (W**AB/W**LB/W**AC Series) Air Conditioners with JADE™ Economizers	27
4	1-Stage (W**AB/W**LB/W**AC Series) Air Conditioners with JADE™ Economizers and Alarm Board & CB5000 Series Communication Board	28
5	2-Stage (W*SAC Series) Air Conditioners – No Economizers	29
6	2-Stage (W*SAC Series) Air Conditioners – No Economizers with Alarm Board & CB5000 Series Communication Board	30
7	2-Stage (W*SAC Series) Air Conditioners with JADE™ Economizers	31
8	2-Stage (W*SAC Series) Air Conditioners with JADE™ Economizers and Alarm Board & CB5000 Series Communication Board	32
9	1-Stage (W**AA/W**LA Series) Air Conditioners – No Economizers	33
10	1-Stage (W**AA/W**LA Series) Air Conditioners – No Economizers with Alarm Board & CB5000 Series Communication Board	34
11	1-Stage (W**AA/W**LA Series) Air Conditioners with WECOP Economizers	35
12	1-Stage (W**AA/W**LA Series) Air Conditioners with WECOP Economizers and with Alarm Board & CB5000 Series Communication Board	36
13	1-Stage (WA/WL, W**A/W**L Series) Air Conditioners – No Economizers	37
14	1-Stage (WA/WL, W**A/W**L Series) Air Conditioners – No Economizers with Alarm Board & CB5000 Series Communication Board	38
15	1-Stage (WA/WL, W**A/W**L Series) Air Conditioners with ECONWM* Economizers	39
16	1-Stage (WA/WL, W**A/W**L Series) Air Conditioners with ECONWM* Economizers and with Alarm Board & CB5000 Series Communication Board	40
17	1-Stage (WA/WL, W**A/W**L Series) Air Conditioners with EIFM Economizers	41
18	1-Stage (WA/WL, W**A/W**L Series) Air Conditioners with EIFM Economizers and with Alarm Board & CB5000 Series Communication Board	42
19	2-Stage (WA*S/WL*S Series) Air Conditioners – No Economizers	43
20	2-Stage (WA*S/WL*S Series) Air Conditioners – No Economizers with Alarm Board & CB5000 Series Communication Board	44
21	2-Stage (WA*S/WL*S Series) Air Conditioners with ECONWM* Economizers	45
22	2-Stage (WA*S/WL*S Series) Air Conditioners with ECONWM* Economizers and with Alarm Board & CB5000 Series Communication Board	46
23	2-Stage (WA*S/WL*S Series) Air Conditioners with EIFM Economizers	47
24	2-Stage (WA*S/WL*S Series) Air Conditioners with EIFM Economizers and with Alarm Board & CB5000 Series Communication Board	48
23	W**HB/W**HC Series Heat Pumps – No Economizers	49
26	W**HB/W**HC Series Heat Pumps – No Economizers and with Alarm Board & CB5000 Series Communication Board	50
27	WH/W**H/SH/S**H Heat Pumps – No Economizers	51
28	WH/W**H/SH/S**H Heat Pumps – No Economizers and with Alarm Board & CB5000 Series Communication Board	52
29	Single Unit with Alarm Board	53

CONTROLLER CONNECTIONS DIAGRAM 1

1-Stage (W**AB/W**LB/W**AC Series) Air Conditioners – No Economizers

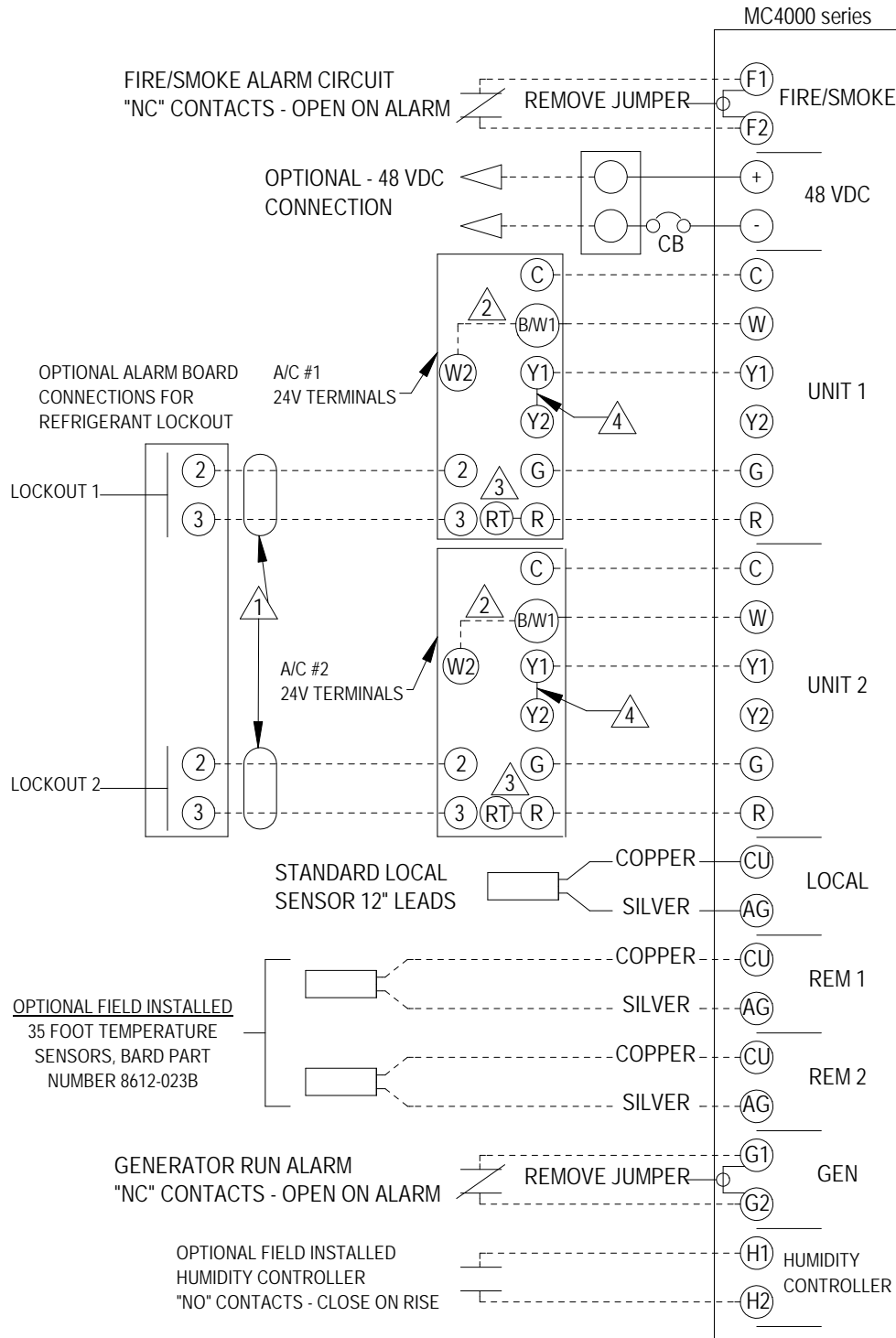

NOTE: DC BACK-UP POWER IS POLARITY SENSITIVE AND MUST BE CONNECTED AS SHOWN OR CONTROLLER WILL NOT OPERATE ON DC POWER ONLY

NOTE: ALL SENSORS ARE POLARITY SENSITIVE. COPPER LEAD MUST CONNECT TO CU, AND SILVER LEAD TO AG.

- ① REQUIRES ALARM RELAY IN EACH A/C UNIT, WHICH IS PART OF "J" CONTROL MODULE.
- ② ADD JUMPER IF 15KW OR HIGHER ELECTRIC HEAT IS INSTALLED
- ③ THE JUMPER BETWEEN RT AND R MUST BE INSTALLED
- ④ FACTORY INSTALLED JUMPER. REMOVE JUMPER AND CONNECT Y2 IN CONTROLLER TO Y2 IN UNIT FOR BALANCED CLIMATE OPERATIONS. SEE UNIT MANUAL FOR INFORMATION ON BALANCED CLIMATE.

MIS-4279 A

CONTROLLER CONNECTIONS DIAGRAM 2

1-Stage (W**AB/W**LB/W**AC Series) Air Conditioners – No Economizers with Alarm Board & CB5000 Series Communication Board

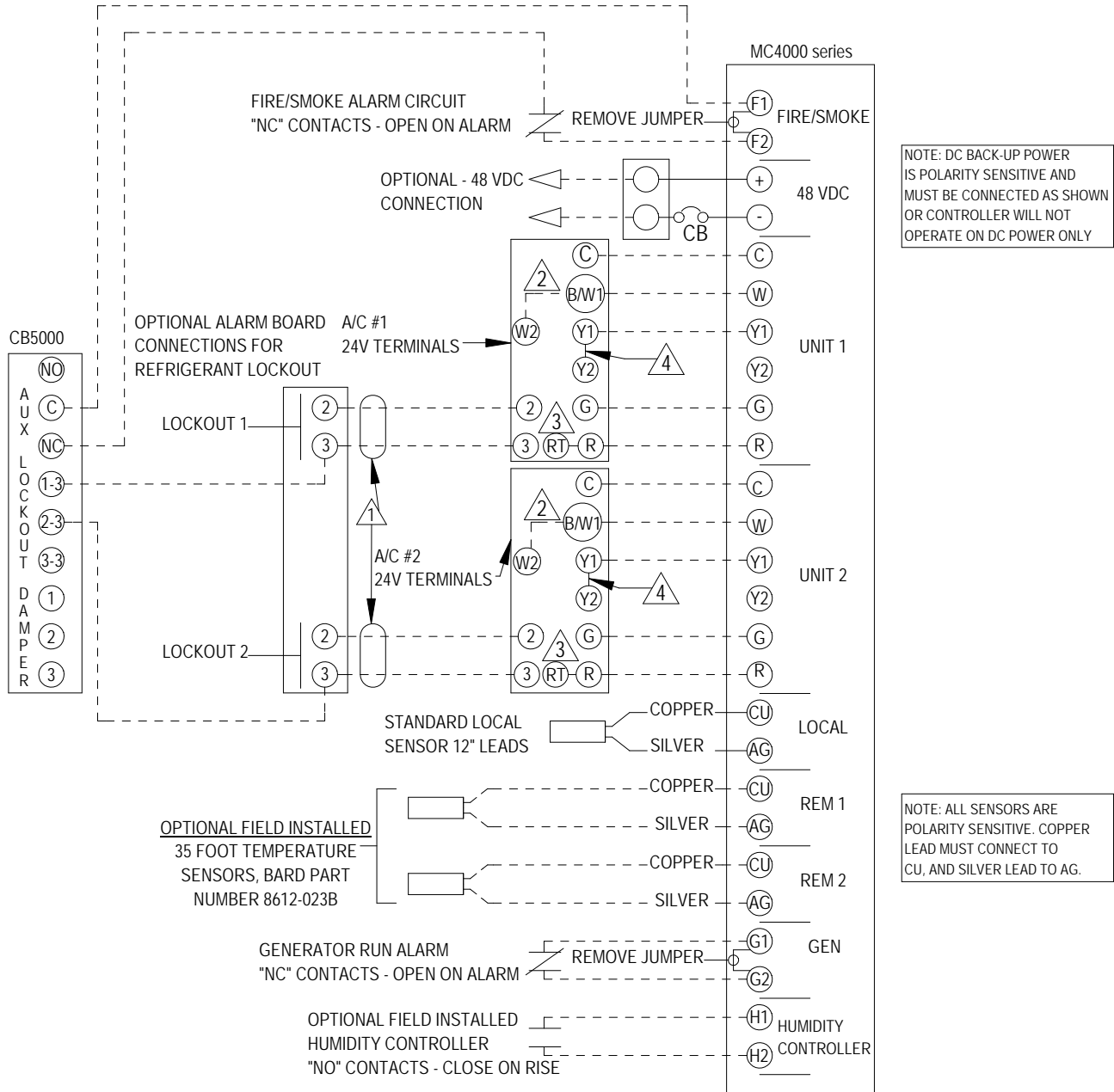

- 1 REQUIRES ALARM RELAY IN EACH A/C UNIT, WHICH IS PART OF "J" CONTROL MODULE.
- 2 ADD JUMPER IF 15KW OR HIGHER ELECTRIC HEAT IS INSTALLED
- 3 THE JUMPER BETWEEN RT AND R MUST BE IN PLACE
- 4 FACTORY INSTALLED JUMPER. REMOVE JUMPER AND CONNECT Y2 IN CONTROLLER TO Y2 IN UNIT FOR BALANCED CLIMATE OPERATIONS. SEE UNIT MANUAL FOR INFORMATION ON BALANCED CLIMATE.

MIS-4278 A

CONTROLLER CONNECTIONS DIAGRAM 3

1-Stage (W**AB/W**LB/W**AC Series) Air Conditioners with JADE™ Economizers

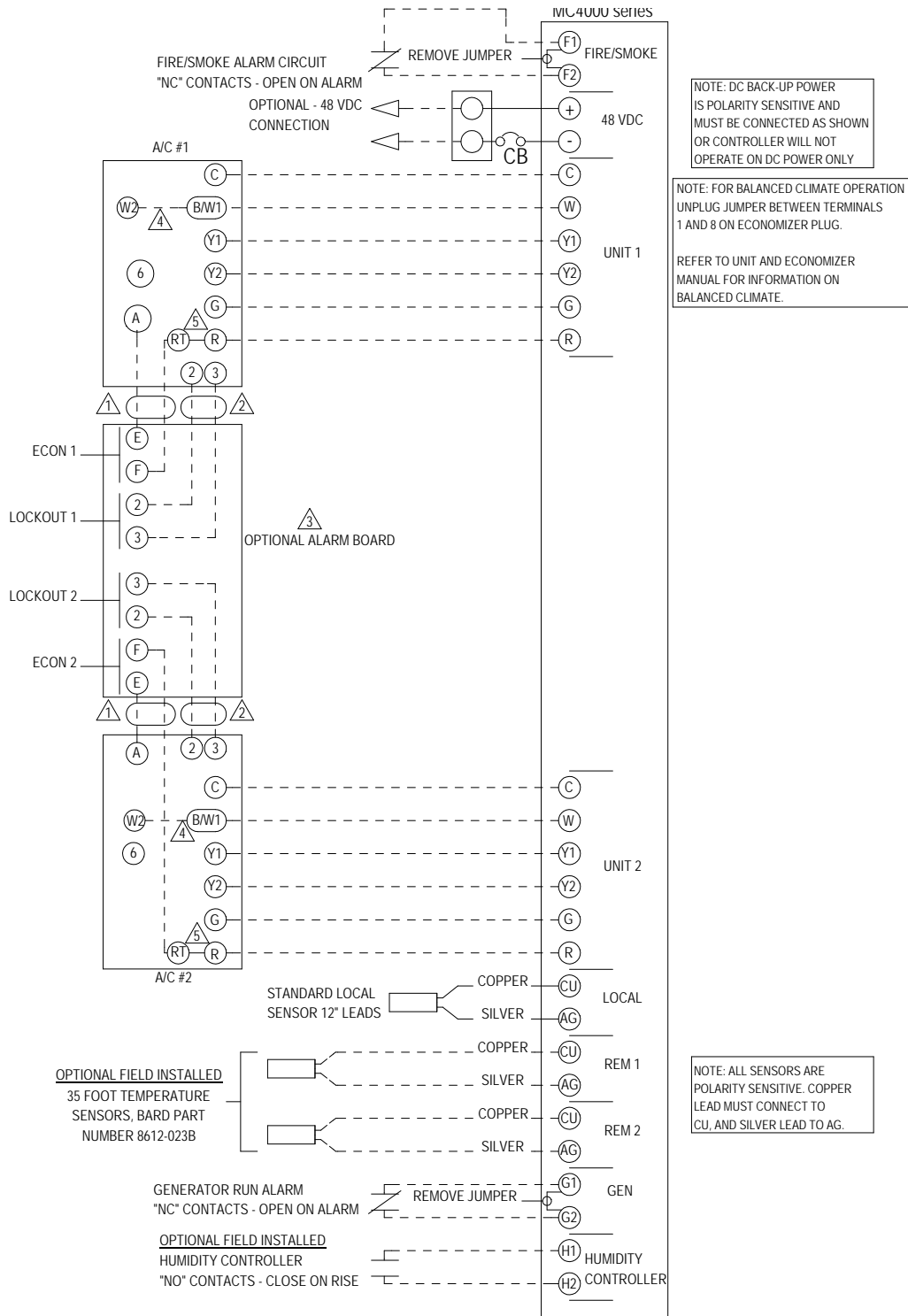

MIS-4280 A

CONTROLLER CONNECTIONS DIAGRAM 4

1-Stage (W**AB/W**LB/W**AC Series) Air Conditioners with JADE™ Economizers and Alarm Board & CB5000 Series Communication Board

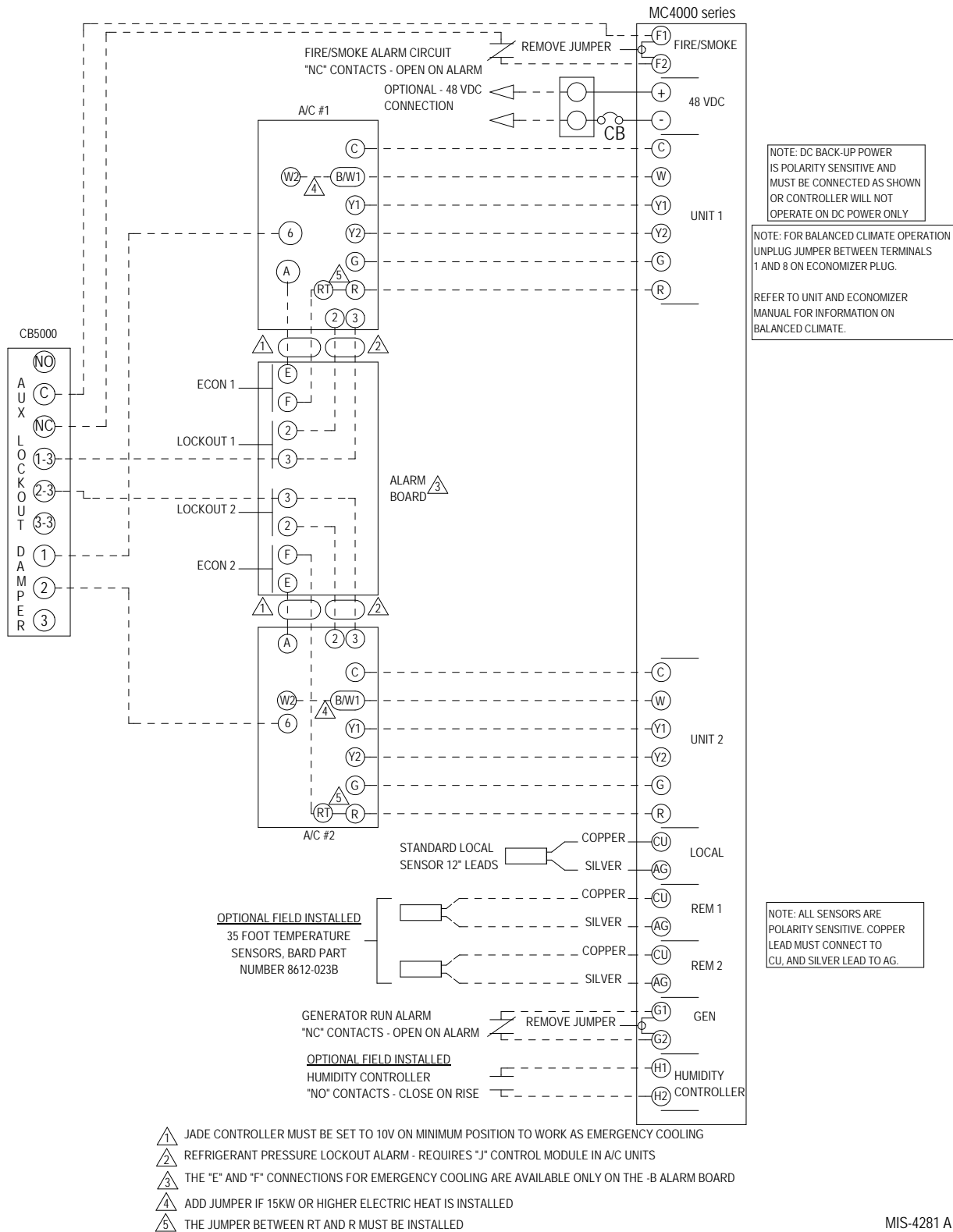

CONTROLLER CONNECTIONS DIAGRAM 5

2-Stage (W*SAC Series) Air Conditioners – No Economizers

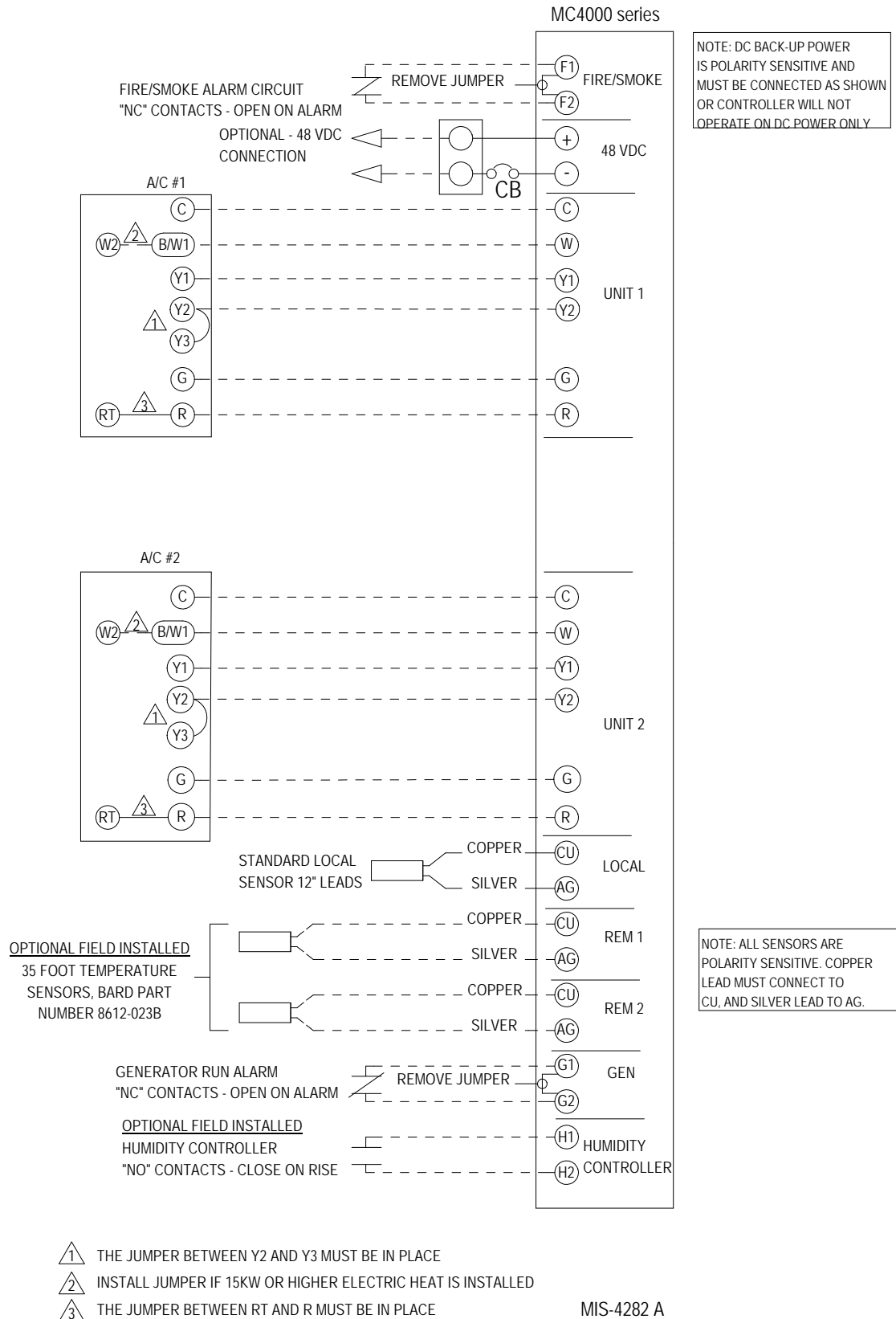

CONTROLLER CONNECTIONS DIAGRAM 6

2-Stage (W*SAC Series) Air Conditioners – No Economizers with Alarm Board & CB5000 Series Communication Board

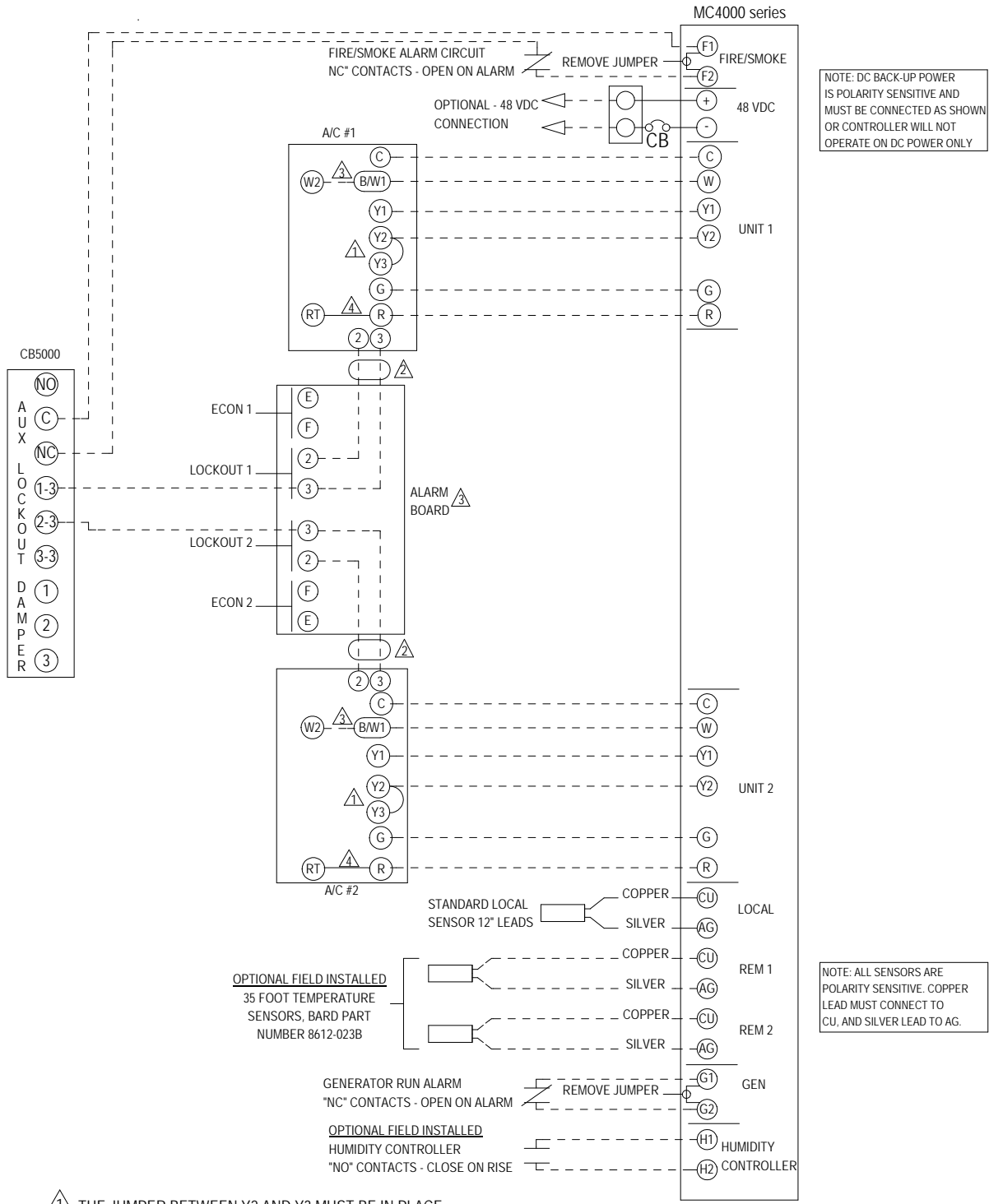

- 1 THE JUMPER BETWEEN Y2 AND Y3 MUST BE IN PLACE
- 2 REFRIGERANT PRESSURE LOCKOUT ALARM - REQUIRES "J" CONTROL MODULE IN A/C UNITS
- 3 INSTALL JUMPER IF 15 KW OR HIGHER ELECTRIC HEAT IS INSTALLED
- 4 THE JUMPER BETWEEN RT AND R MUST BE IN PLACE

WIS-4283 A

CONTROLLER CONNECTIONS DIAGRAM 7

2-Stage (W*SAC Series) Air Conditioners with JADE™ Economizers

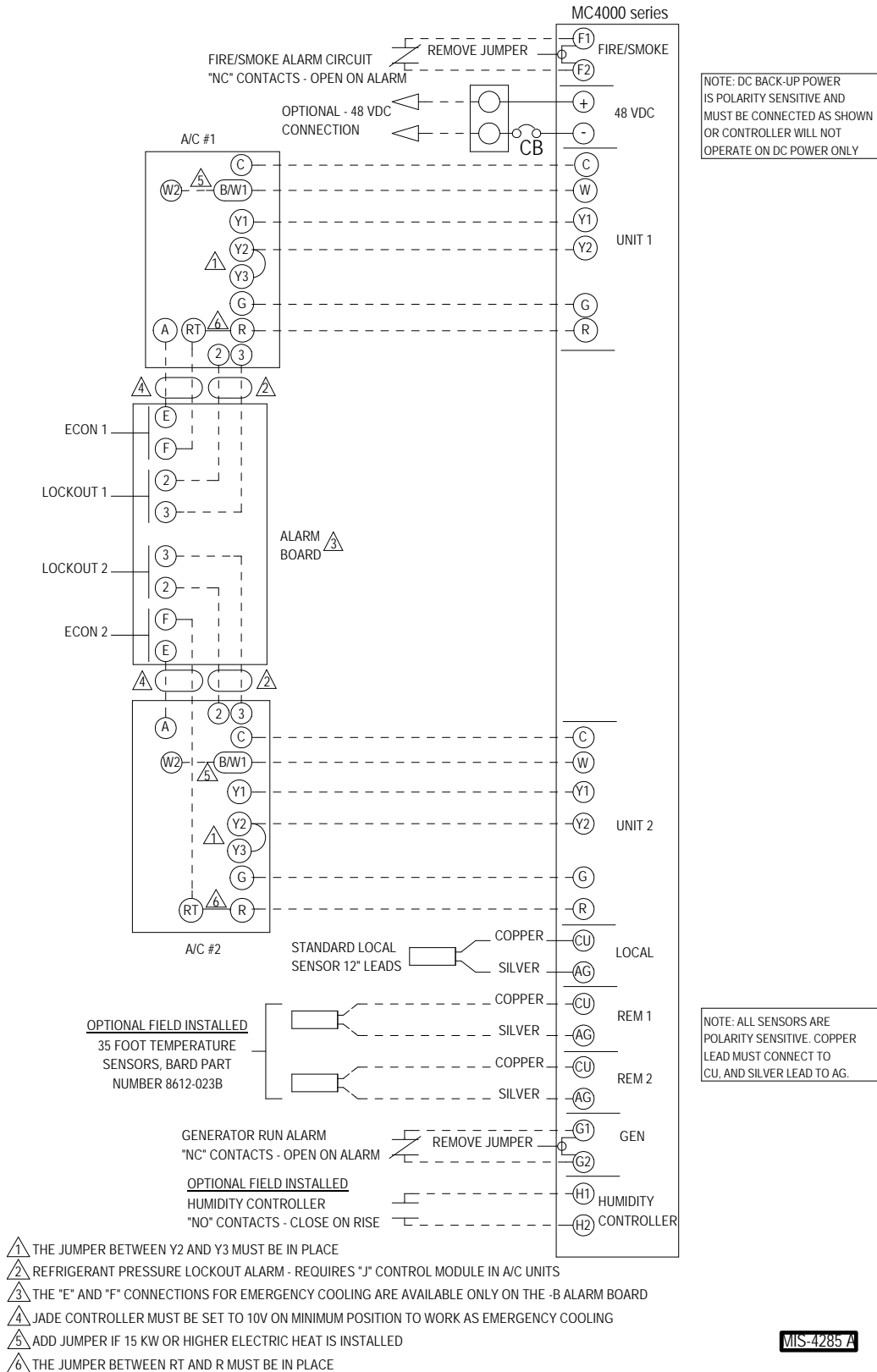

MIS-4285 A

CONTROLLER CONNECTIONS DIAGRAM 8

2-Stage (W*SAC Series) Air Conditioners

with JADE™ Economizers and Alarm Board & CB5000 Series Communication Board

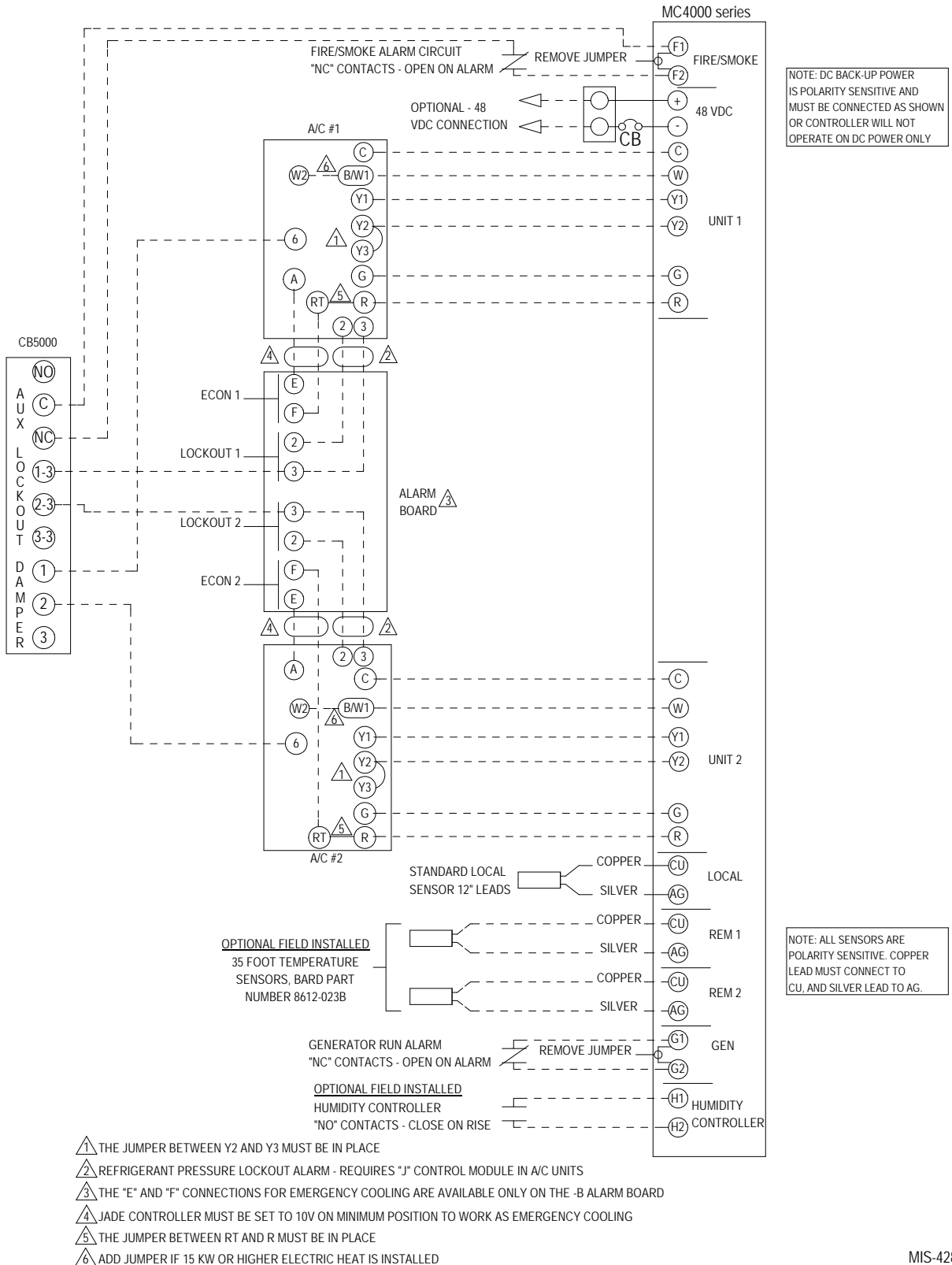

MIS-4286 A

CONTROLLER CONNECTIONS DIAGRAM 9

1-Stage (W**AA/W**LA Series) Air Conditioners – No Economizers

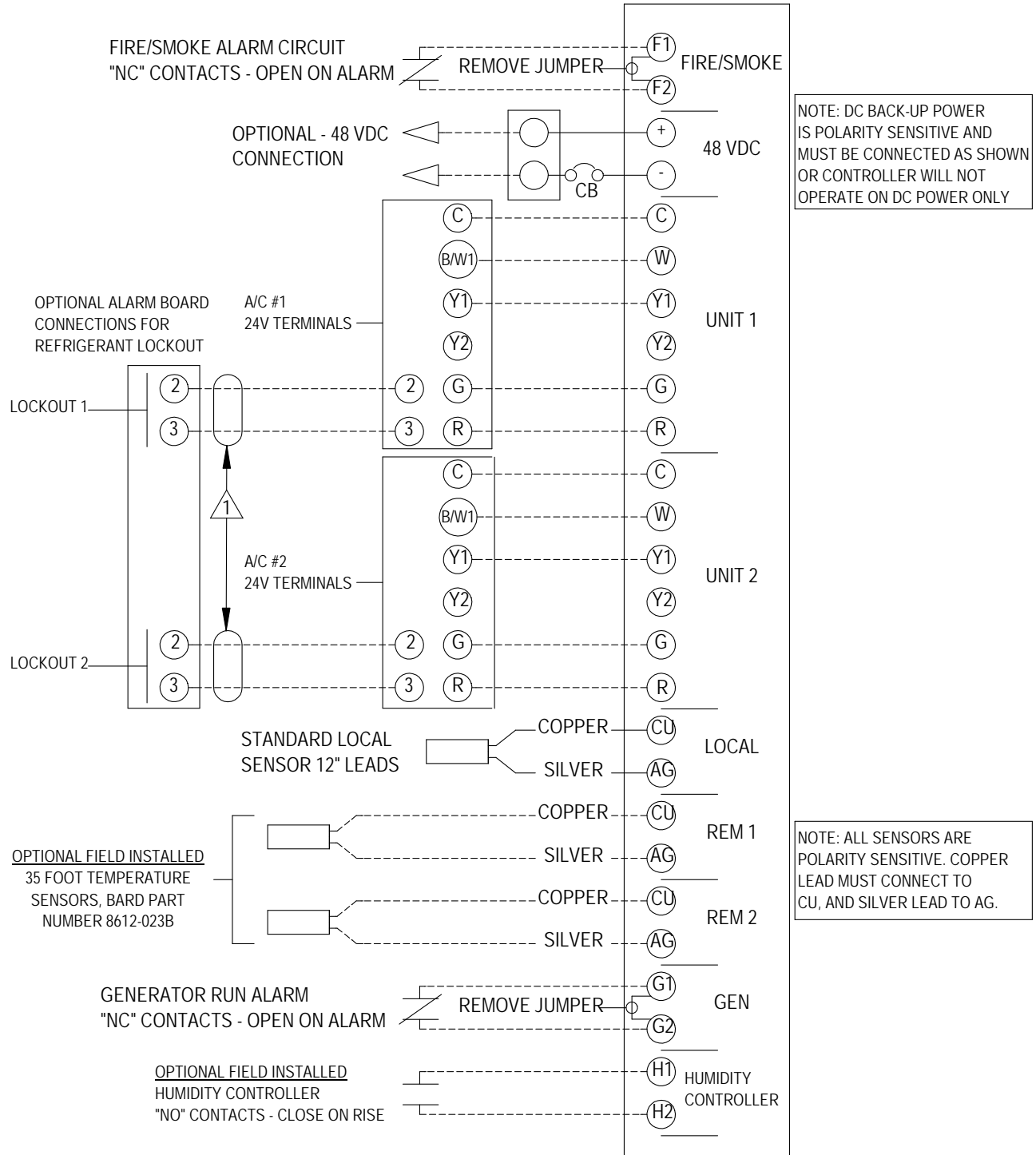

REQUIRES ALARM RELAY IN EACH A/C UNIT, WHICH IS PART OF "J" CONTROL MODULE.

MIS-3827 B

CONTROLLER CONNECTIONS DIAGRAM 10

1-Stage (W**AA/W**LA Series) Air Conditioners – No Economizers with Alarm Board & CB5000 Series Communication Board

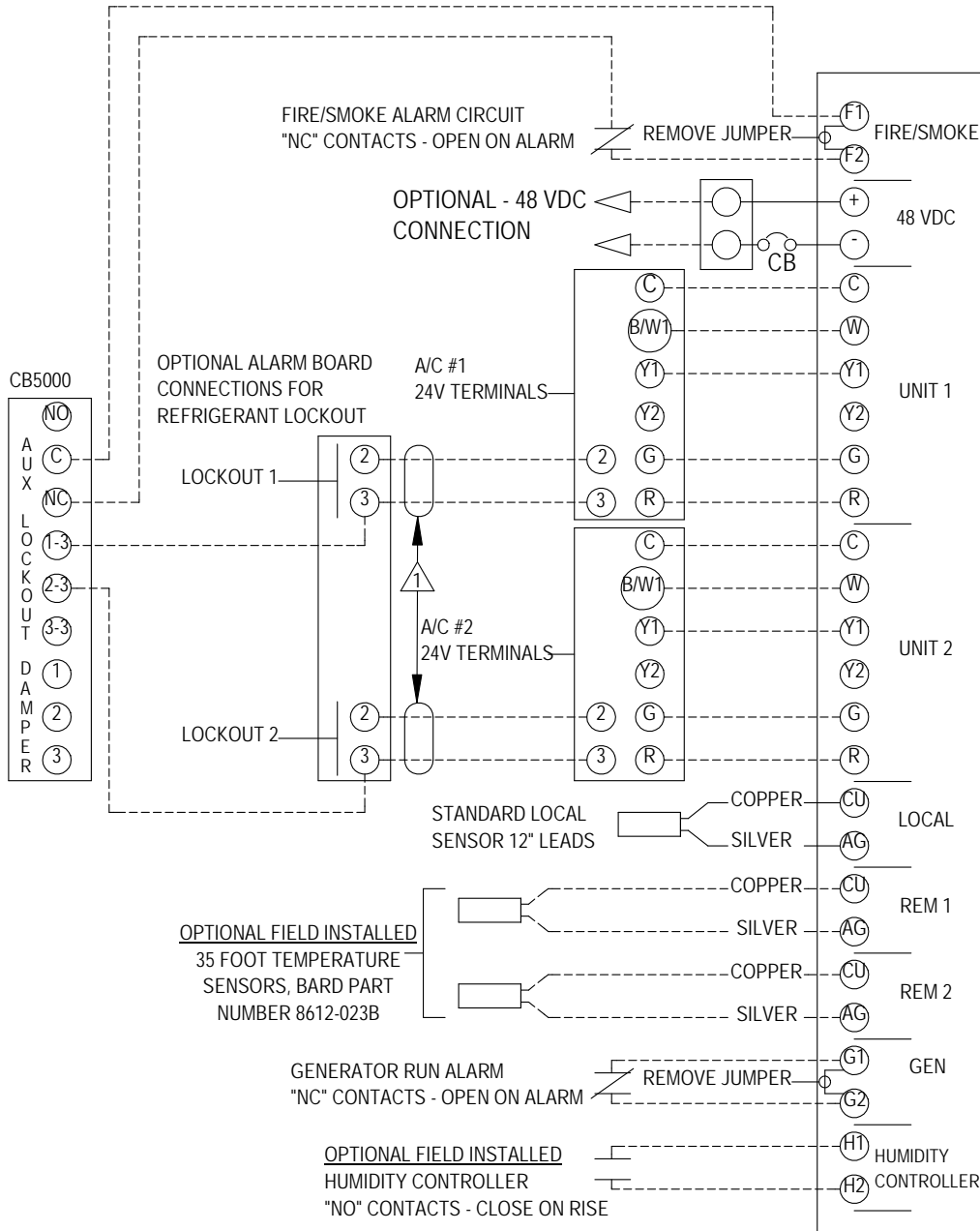

NOTE: DC BACK-UP POWER IS POLARITY SENSITIVE AND MUST BE CONNECTED AS SHOWN OR CONTROLLER WILL NOT OPERATE ON DC POWER ONLY

NOTE: ALL SENSORS ARE POLARITY SENSITIVE. COPPER LEAD MUST CONNECT TO CU, AND SILVER LEAD TO AG.

△ REQUIRES ALARM RELAY IN EACH A/C UNIT, WHICH IS PART OF "J" CONTROL MODULE.

MIS-3828 B

CONTROLLER CONNECTIONS DIAGRAM 11

1-Stage (W**AA/W**LA Series) Air Conditioners with WECOP Economizers

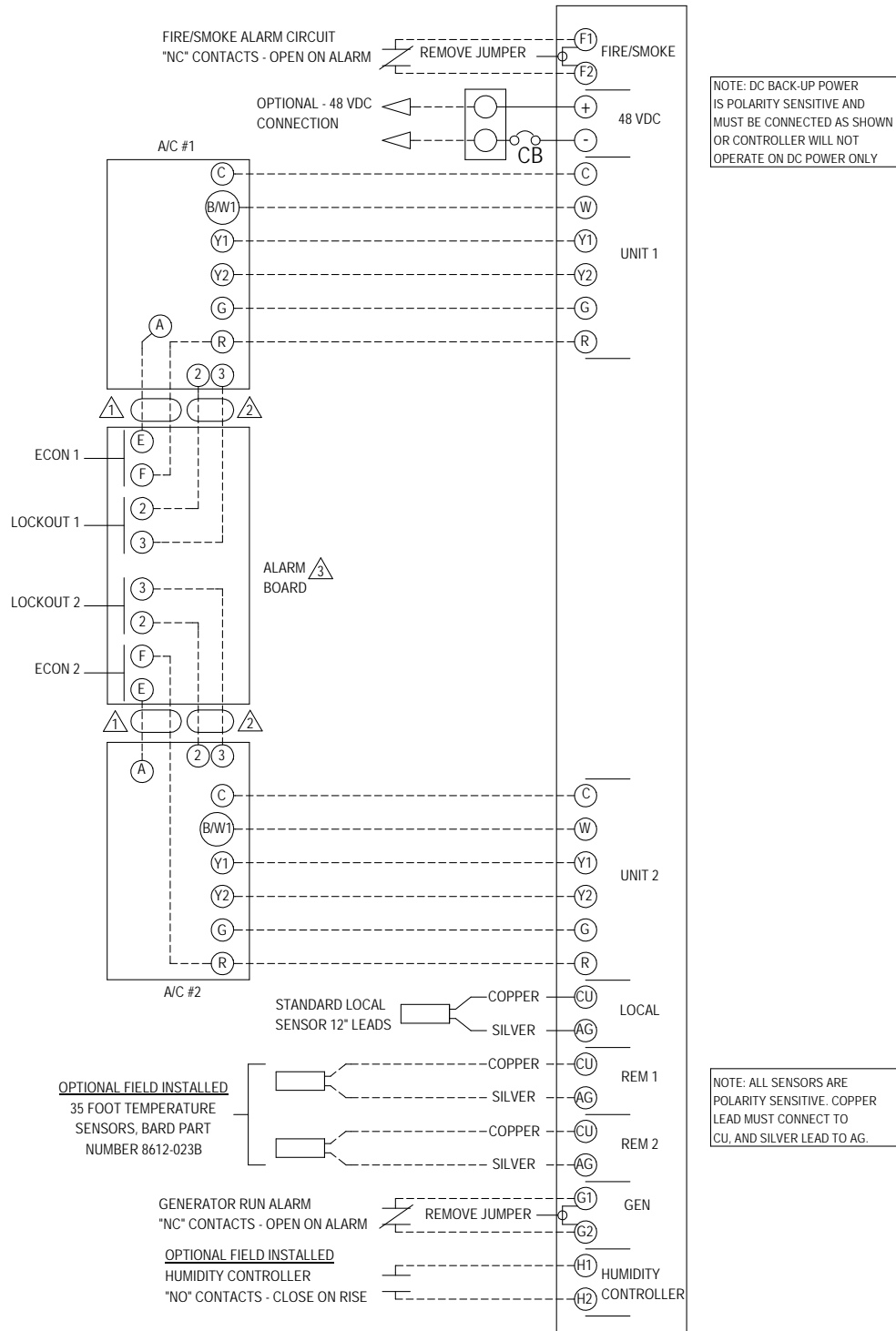

- ① JADE CONTROLLER MUST BE SET TO 10V ON MINIMUM POSITION TO WORK AS EMERGENCY COOLING
- ② REFRIGERANT PRESSURE LOCKOUT ALARM - REQUIRES "J" CONTROL MODULE IN A/C UNITS
- ③ THE "E" AND "F" CONNECTIONS FOR EMERGENCY COOLING ARE AVAILABLE ONLY ON THE -B ALARM BOARD

MIS-3829 B

CONTROLLER CONNECTIONS DIAGRAM 12
1-Stage (WAA/W**LA Series) Air Conditioners**
with WECOP Economizers
and with Alarm Board & CB5000 Series Communication Board

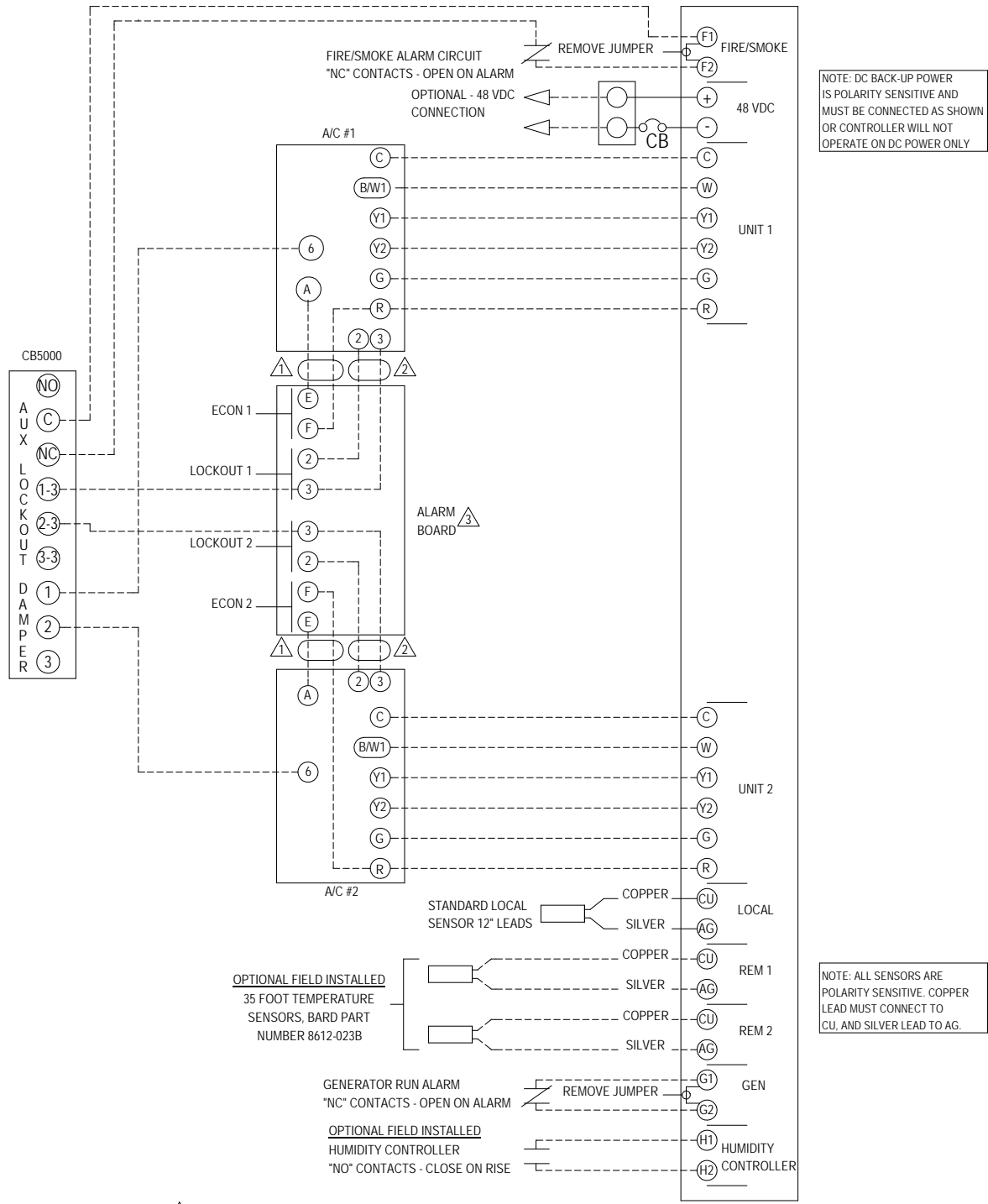

NOTE: DC BACK-UP POWER IS POLARITY SENSITIVE AND MUST BE CONNECTED AS SHOWN OR CONTROLLER WILL NOT OPERATE ON DC POWER ONLY

NOTE: ALL SENSORS ARE POLARITY SENSITIVE. COPPER LEAD MUST CONNECT TO CU, AND SILVER LEAD TO AG.

- △1 JADE CONTROLLER MUST BE SET TO 10V ON MINIMUM POSITION TO WORK AS EMERGENCY COOLING
- △2 REFRIGERANT PRESSURE LOCKOUT ALARM - REQUIRES "J" CONTROL MODULE IN A/C UNITS
- △3 THE "E" AND "F" CONNECTIONS FOR EMERGENCY COOLING ARE AVAILABLE ONLY ON THE -B ALARM BOARD

MIS-3830 C

CONTROLLER CONNECTIONS DIAGRAM 13

1-Stage (WA/WL, W**A/W**L Series) Air Conditioners – No Economizers

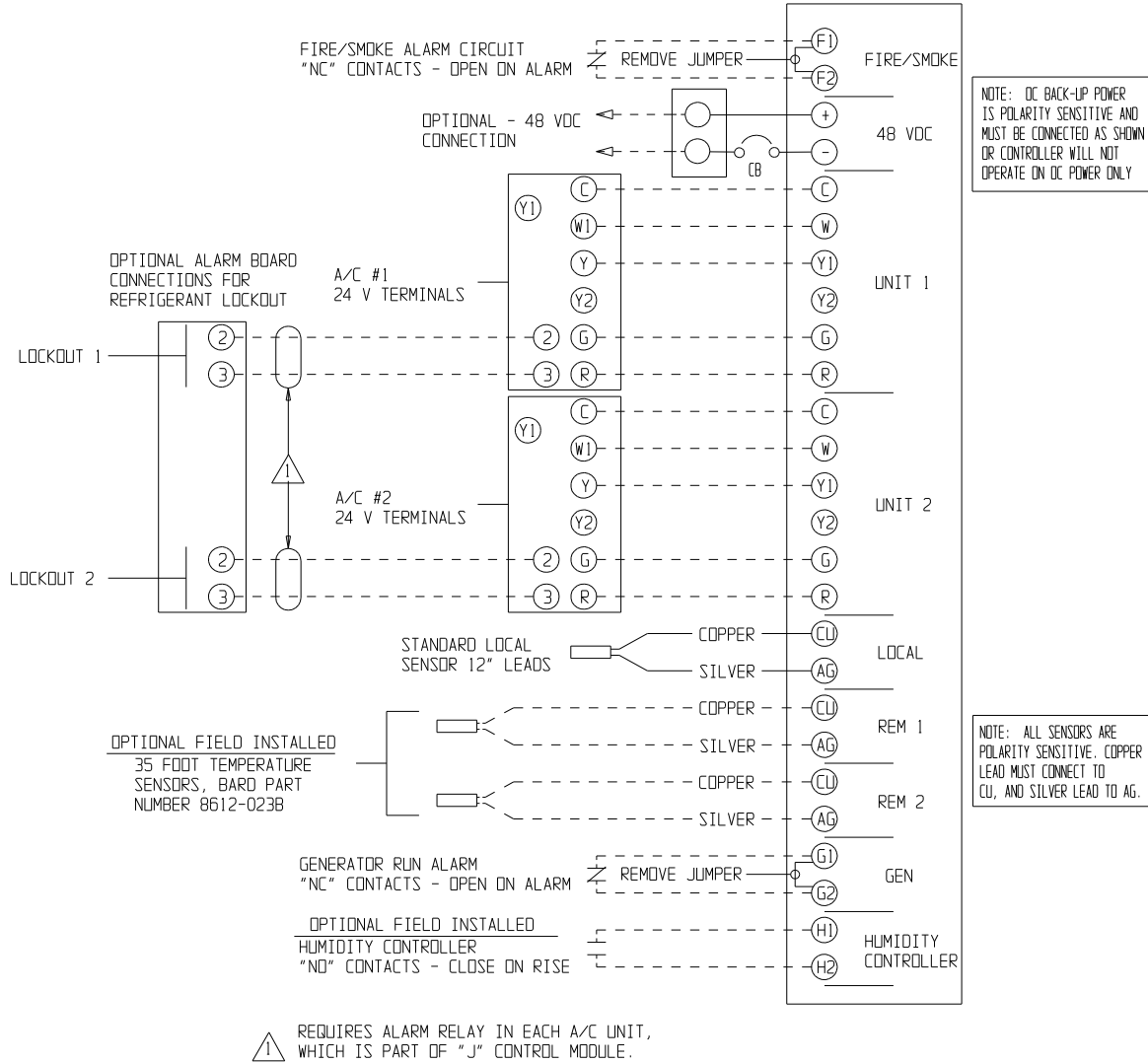

MIS-2012 E

CONTROLLER CONNECTIONS DIAGRAM 14

1-Stage (WA/WL, W**A/W**L Series) Air Conditioners – No Economizers with Alarm Board & CB5000 Series Communication Board

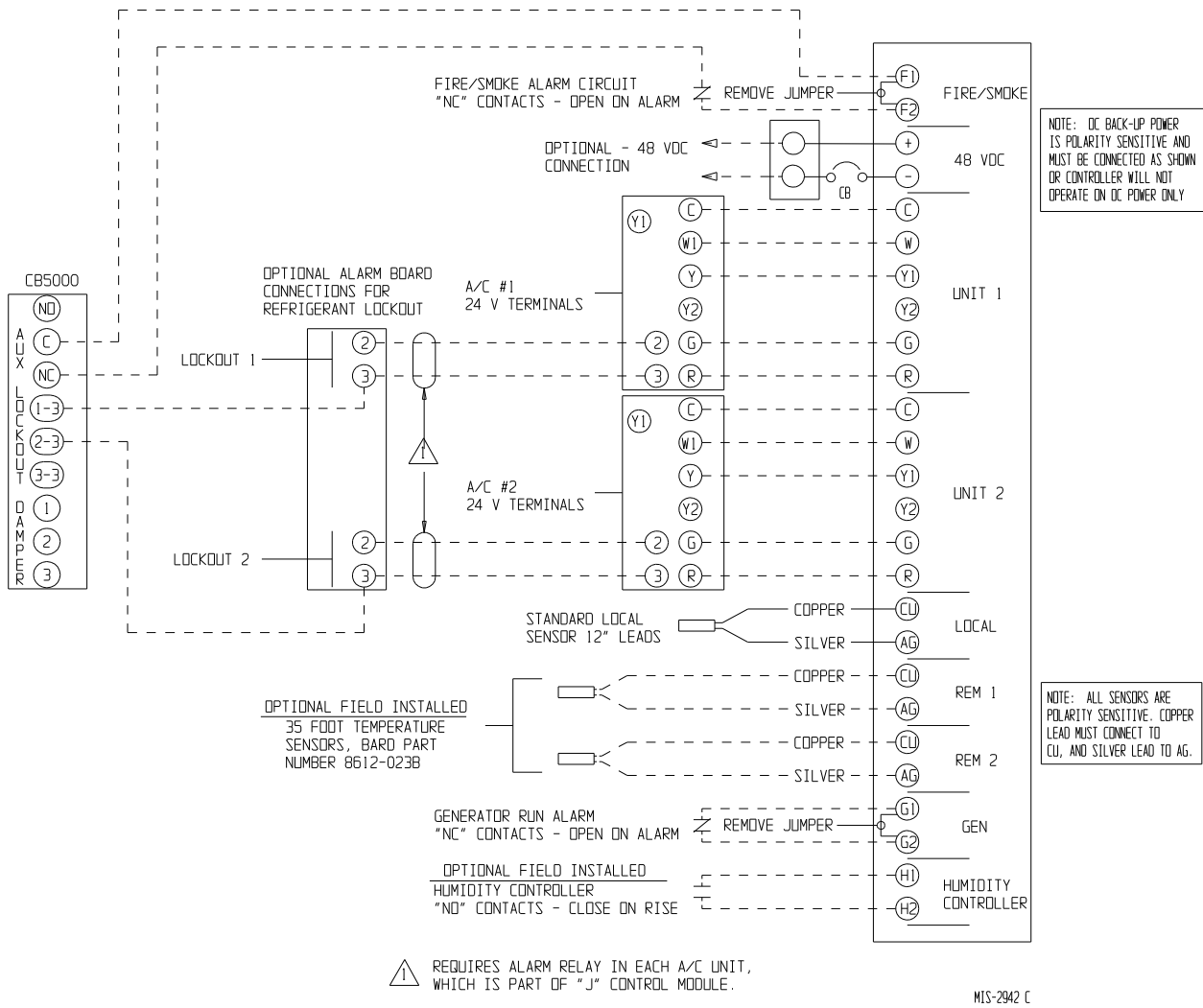

CONTROLLER CONNECTIONS DIAGRAM 15

1-Stage (WA/WL, W**A/W**L Series) Air Conditioners with ECONWM* Economizers

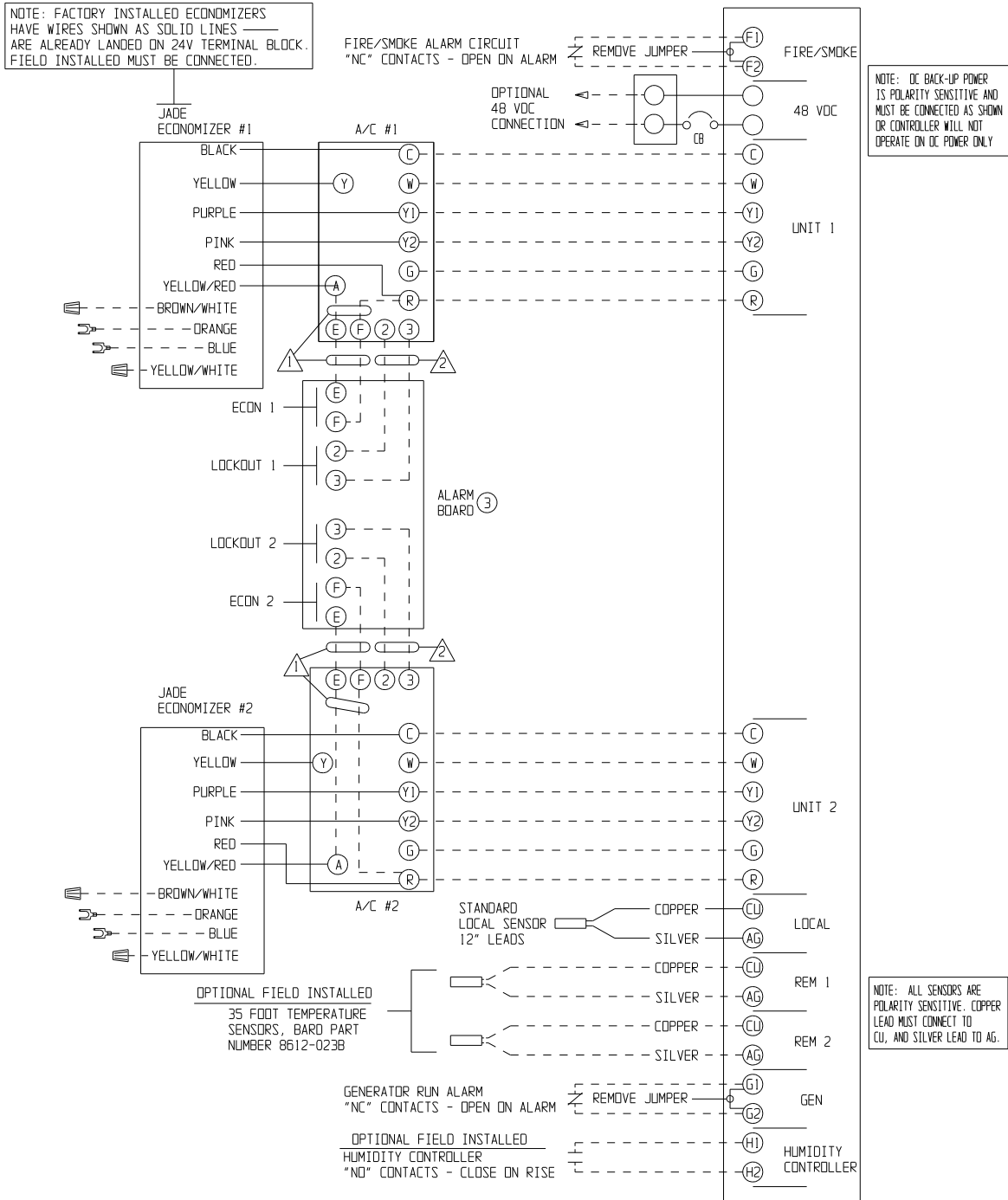

① FOR EMERGENCY COOLING WIRE AS SHOWN. IN JADE ECONOMIZER CONTROLLER SET THE ECONOMIZER MIN. POS. TO 10V.

② REFRIGERANT PRESSURE LOCKOUT ALARM - REQUIRES "J" CONTROL MODULE IN A/C UNITS.

③ THE "E" AND "F" CONNECTIONS FOR EMERGENCY COOLING ARE AVAILABLE ONLY ON THE -B ALARM BOARD.

MIS-2948 F

CONTROLLER CONNECTIONS DIAGRAM 16

1-Stage (WA/WL, W**A/W**L Series) Air Conditioners with ECONWM* Economizers and with Alarm Board & CB5000 Series Communication Board

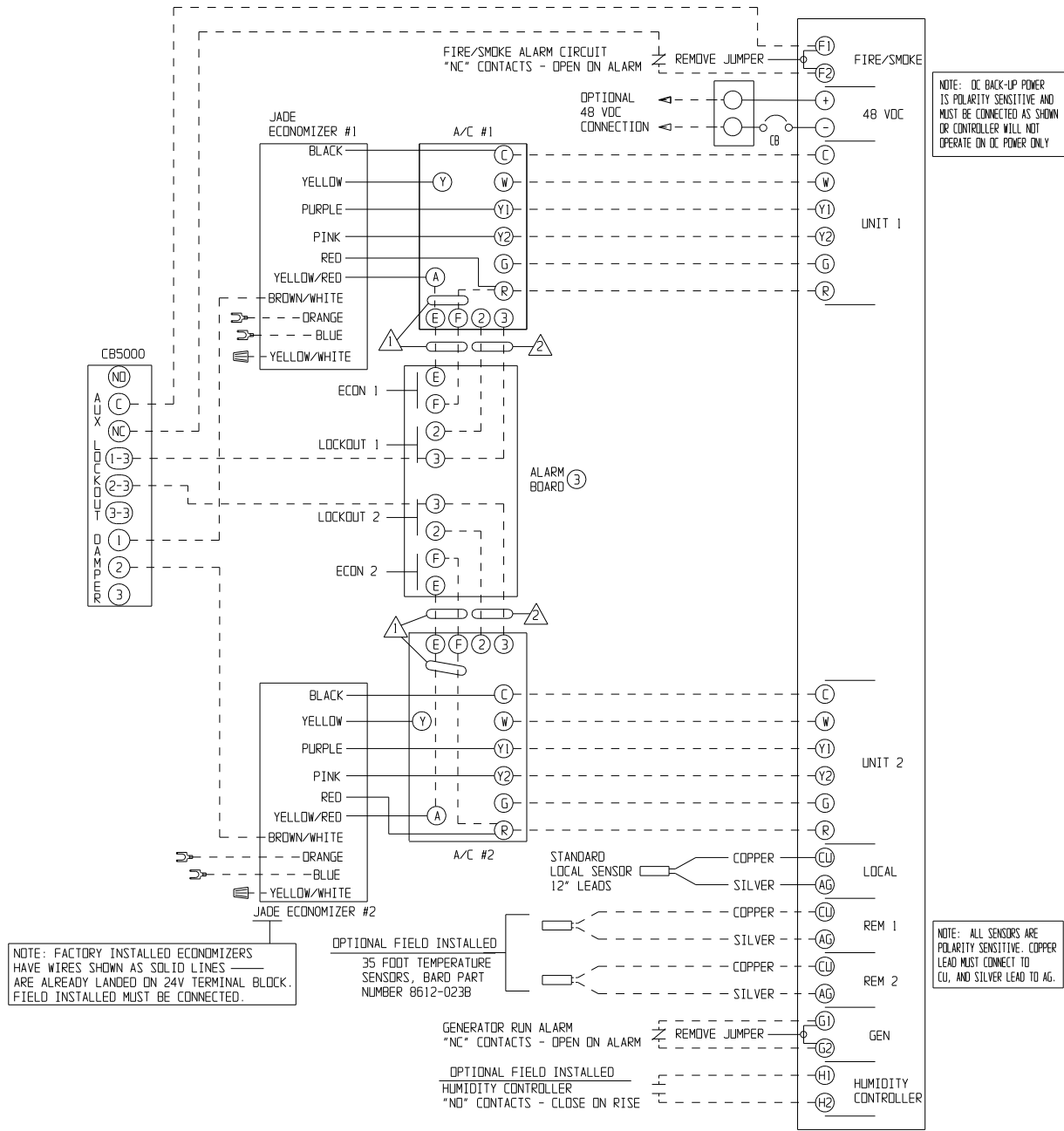

CONTROLLER CONNECTIONS DIAGRAM 17

1-Stage (WA/WL, W**A/W**L Series) Air Conditioners with EIFM Economizers

NOTE: FACTORY INSTALLED ECONOMIZERS HAVE WIRES SHOWN AS SOLID LINES — ARE ALREADY LANDED ON 24V TERMINAL BLOCK. FIELD INSTALLED MUST BE CONNECTED.

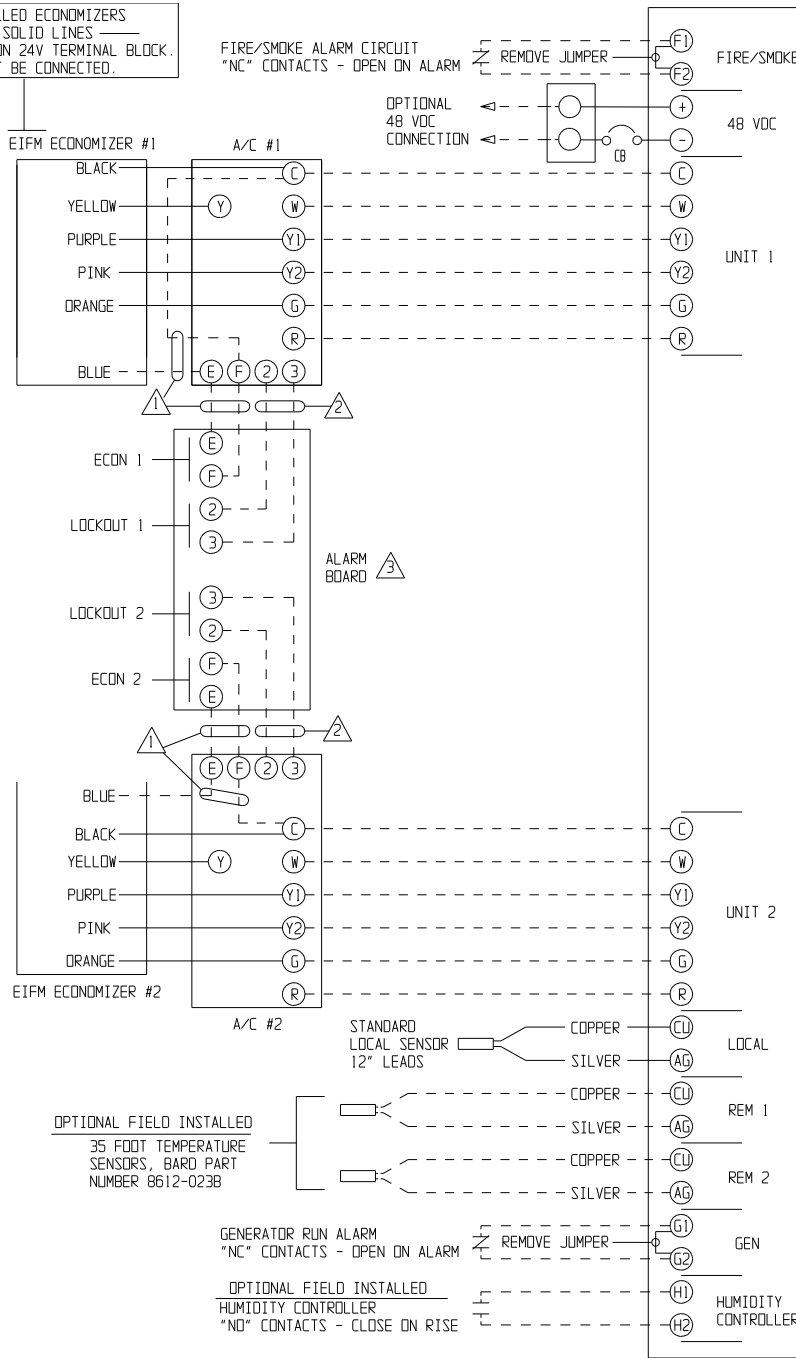

NOTE: DC BACK-UP POWER IS POLARITY SENSITIVE AND MUST BE CONNECTED AS SHOWN OR CONTROLLER WILL NOT OPERATE ON DC POWER ONLY.

NOTE: ALL SENSORS ARE POLARITY SENSITIVE. COPPER LEAD MUST CONNECT TO CU, AND SILVER LEAD TO AG.

- ⚠ FOR EMERGENCY COOLING IN THE JADE ECONOMIZER CONTROLLER SET THE ECONOMIZER MINIMUM POSITION TO 10 VOLTS.
- ⚠ REFRIGERANT PRESSURE LOCKOUT ALARM - REQUIRES "J" CONTROL MODULE IN A/C UNITS.
- ⚠ THE "E" AND "F" CONNECTIONS FOR EMERGENCY COOLING ARE AVAILABLE ONLY ON THE -B ALARM BOARD.

MIS-2944 0

CONTROLLER CONNECTIONS DIAGRAM 18

1-Stage (WA/WL, W**A/W**L Series) Air Conditioners with EIFM Economizers and with Alarm Board & CB5000 Series Communication Board

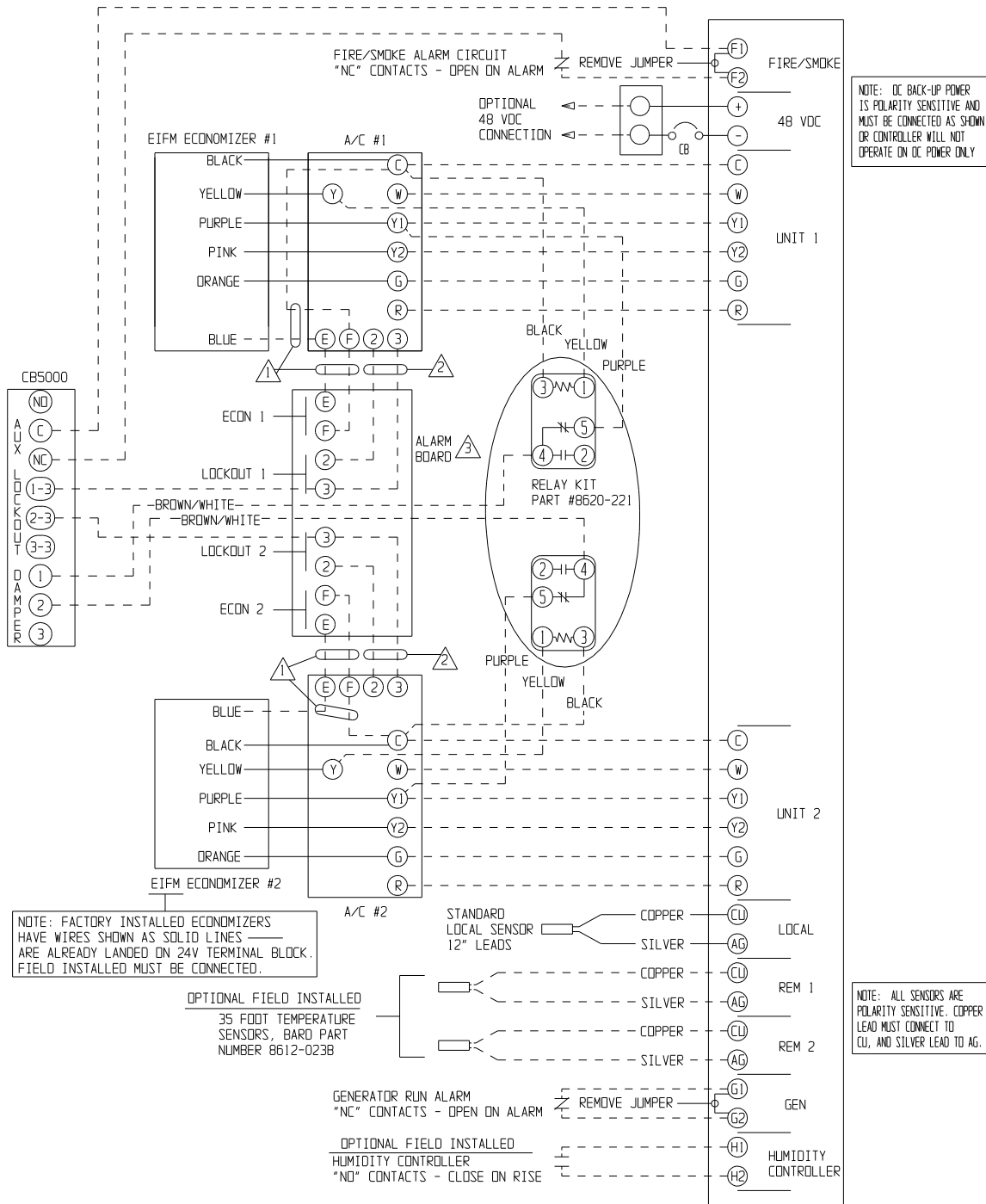

- ⚠ FOR EMERGENCY COOLING IN THE JADE ECONOMIZER CONTROLLER SET THE ECONOMIZER MINIMUM POSITION TO 10 VOLTS.
- ⚠ REFRIGERANT PRESSURE LOCKOUT ALARM - REQUIRES "J" CONTROL MODULE IN A/C UNITS.
- ⚠ THE "E" AND "F" CONNECTIONS FOR EMERGENCY COOLING ARE AVAILABLE ONLY ON THE -B ALARM BOARD.

MIS-2946 D

CONTROLLER CONNECTIONS DIAGRAM 19

2-Stage (WA*S/WL*S Series) Air Conditioners – No Economizers

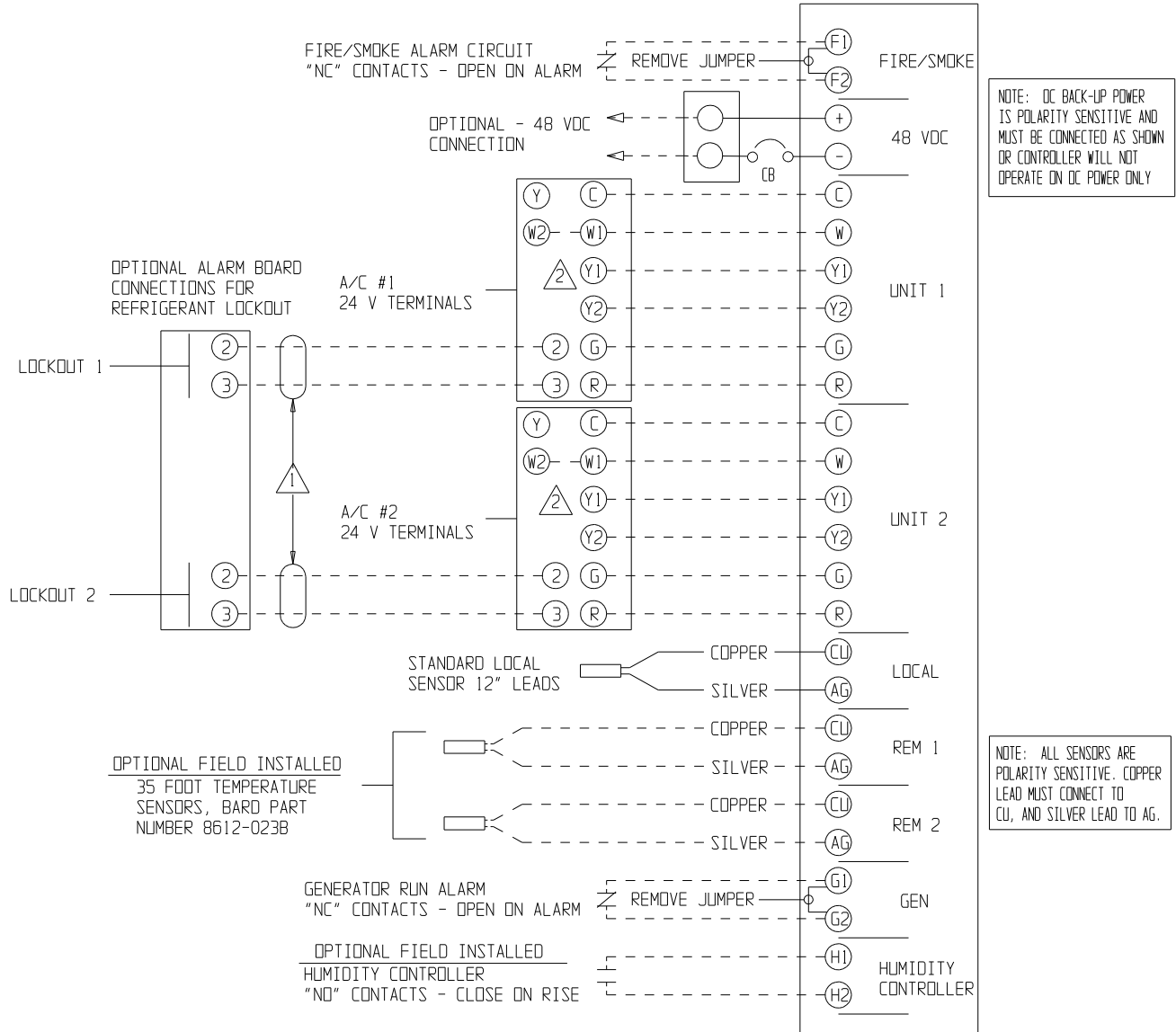

① REQUIRES ALARM RELAY IN EACH A/C UNIT, WHICH IS PART OF "J" CONTROL MODULE.

② INSTALL JUMPER IF 15K OR HIGHER ELECTRIC HEAT IS INSTALLED

MIS-2421 E

CONTROLLER CONNECTIONS DIAGRAM 20

2-Stage (WA*S/WL*S Series) Air Conditioners – No Economizers with Alarm Board & CB5000 Series Communication Board

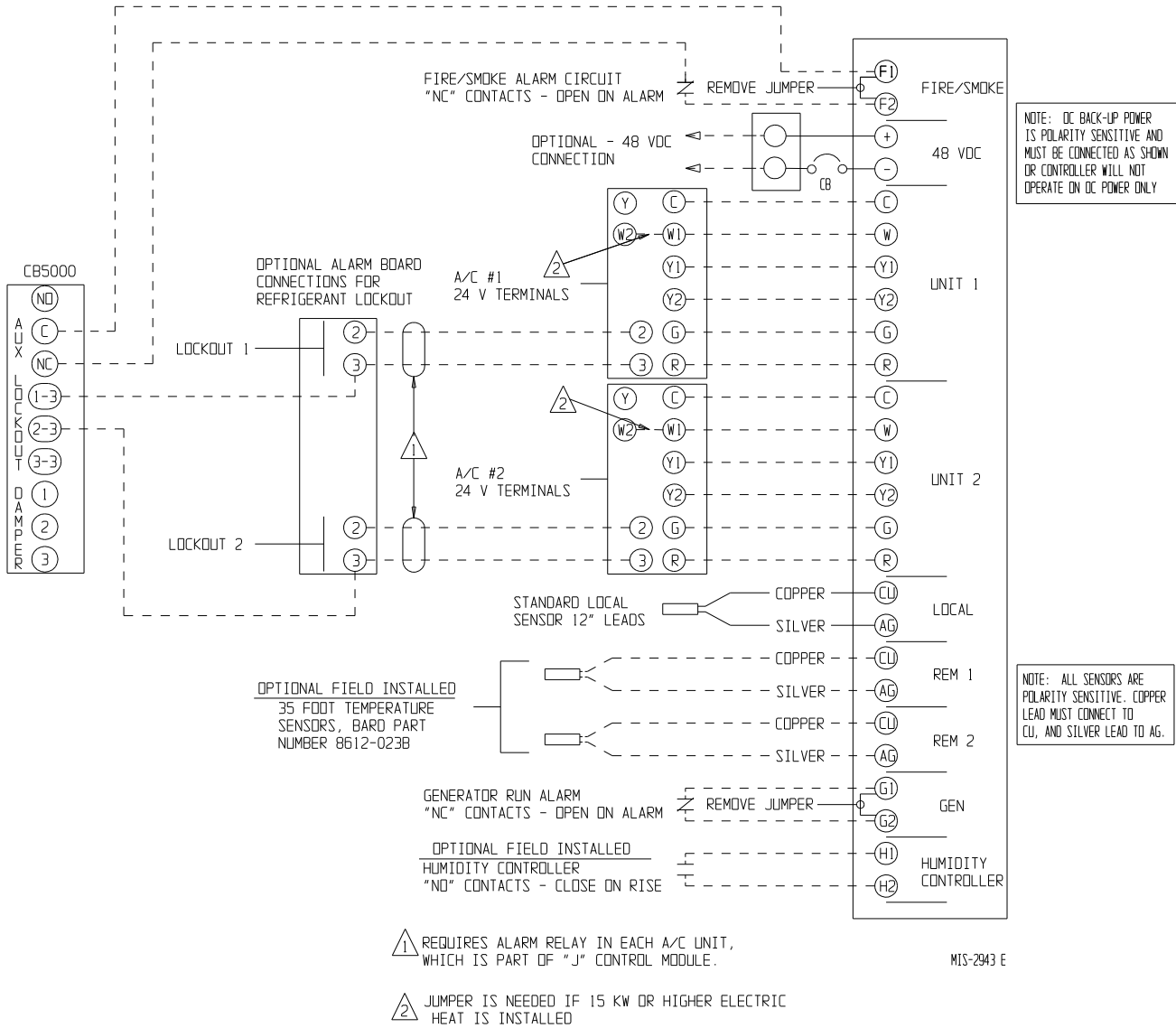

CONTROLLER CONNECTIONS DIAGRAM 21

2-Stage (WA*S/WL*S Series) Air Conditioners with ECONWM* Economizers

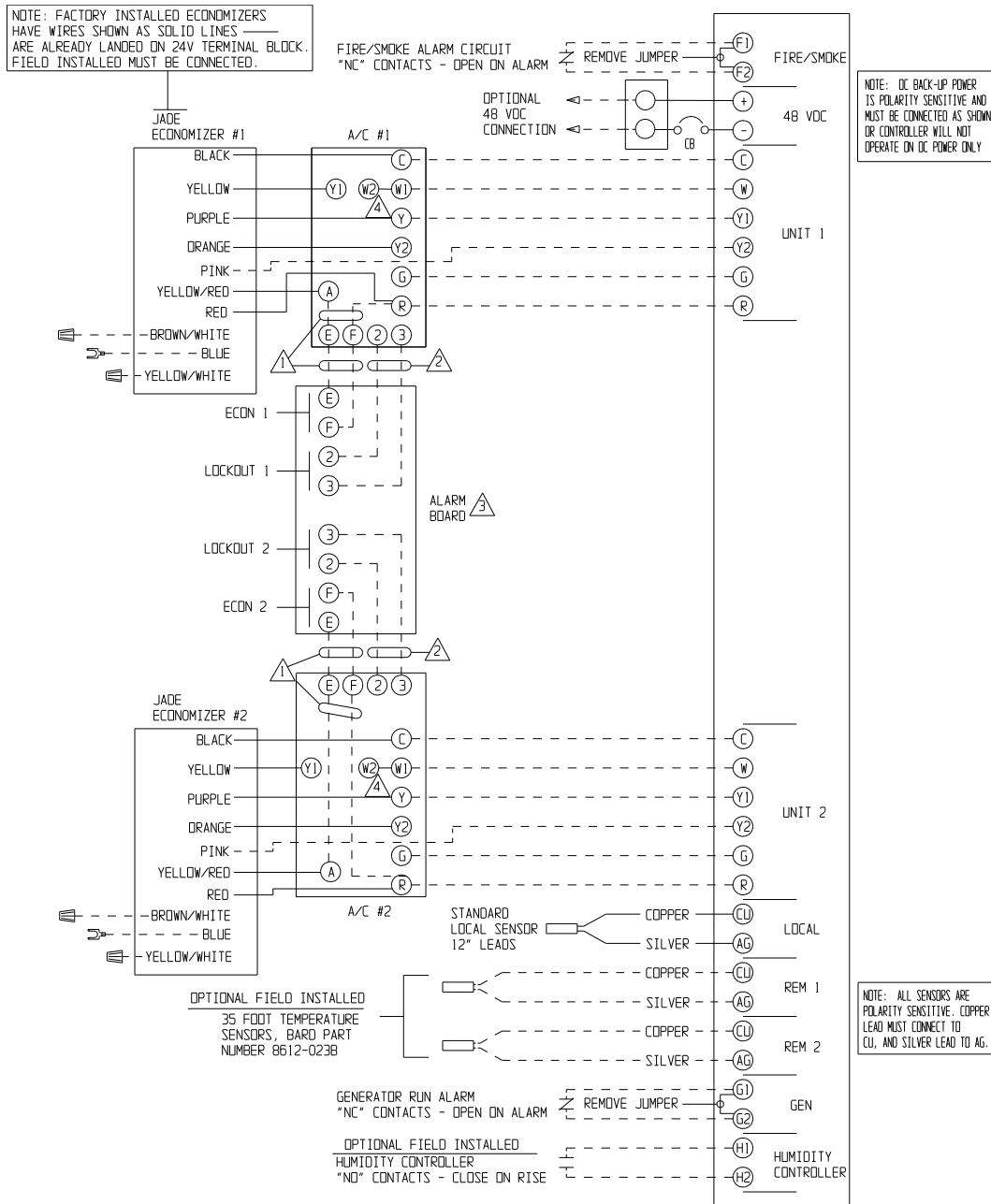

- ⚠ FOR EMERGENCY COOLING WIRE AS SHOWN. IN JADE ECONOMIZER CONTROLLER SET THE ECONOMIZER MIN. POS. TO 10V.
- ⚠ REFRIGERANT PRESSURE LOCKOUT ALARM - REQUIRES "J" CONTROL MODULE IN A/C UNITS.
- ⚠ THE "E" AND "F" CONNECTIONS FOR EMERGENCY COOLING ARE AVAILABLE ONLY ON THE -B ALARM BOARD.
- ⚠ INSTALL JUMPER IF 15K OR HIGHER ELECTRIC HEAT IS INSTALLED

MIS-2949 G

CONTROLLER CONNECTIONS DIAGRAM 23

2-Stage (WA*S/WL*S Series) Air Conditioners with EIFM Economizers

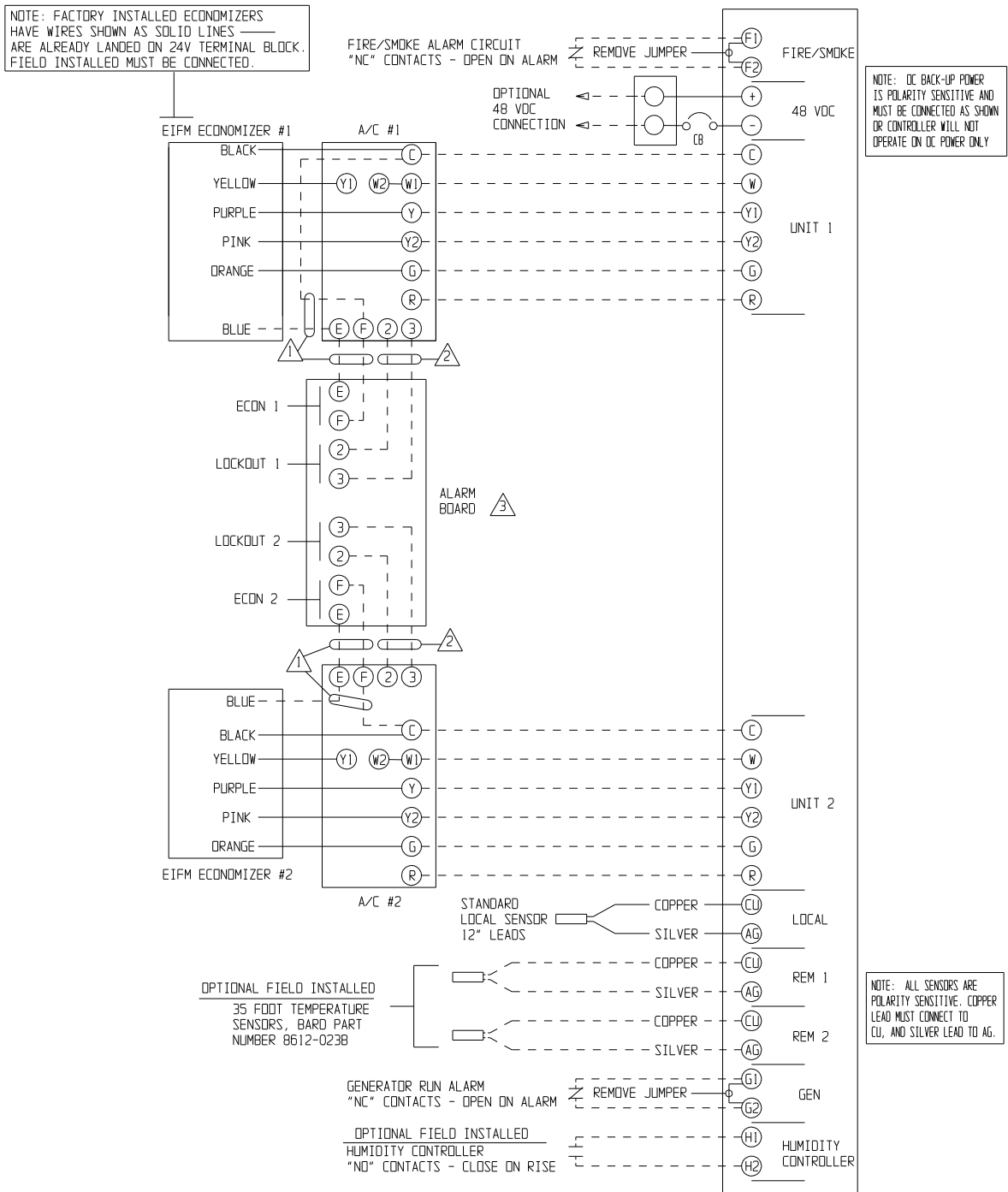

- ⚠ FOR EMERGENCY COOLING IN THE JADE ECONOMIZER CONTROLLER SET THE ECONOMIZER MINIMUM POSITION TO 10 VOLTS.
- ⚠ REFRIGERANT PRESSURE LOCKOUT ALARM - REQUIRES "J" CONTROL MODULE IN A/C UNITS.
- ⚠ THE "E" AND "F" CONNECTIONS FOR EMERGENCY COOLING ARE AVAILABLE ONLY ON THE -B ALARM BOARD.

MIS-2945 E

CONTROLLER CONNECTIONS DIAGRAM 25

W**HB/W**HC Series Heat Pumps – No Economizers

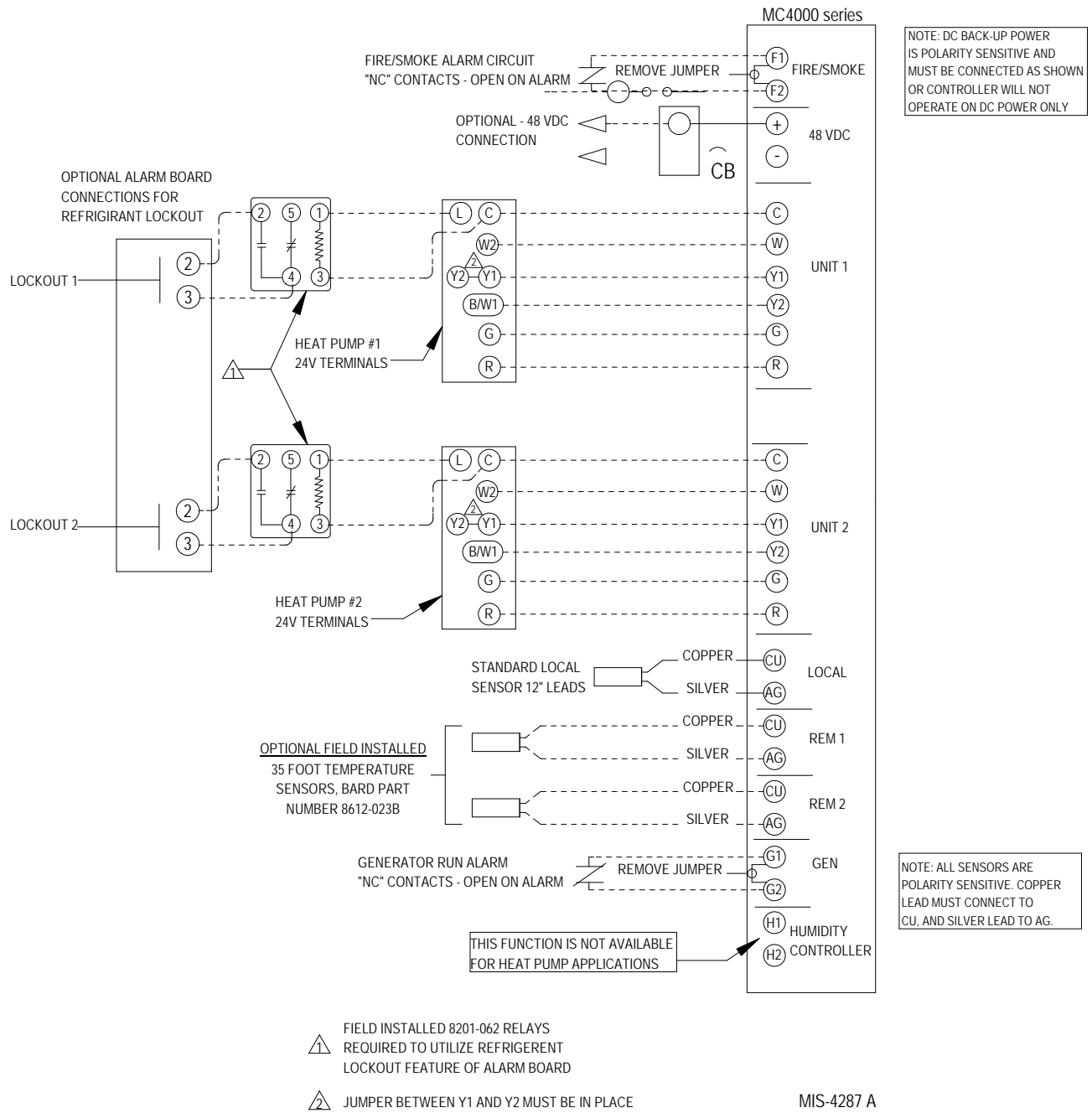

CONTROLLER CONNECTIONS DIAGRAM 26
WHB/W**HC Series Heat Pumps – No Economizers**
and with Alarm Board & CB5000 Series Communication Board

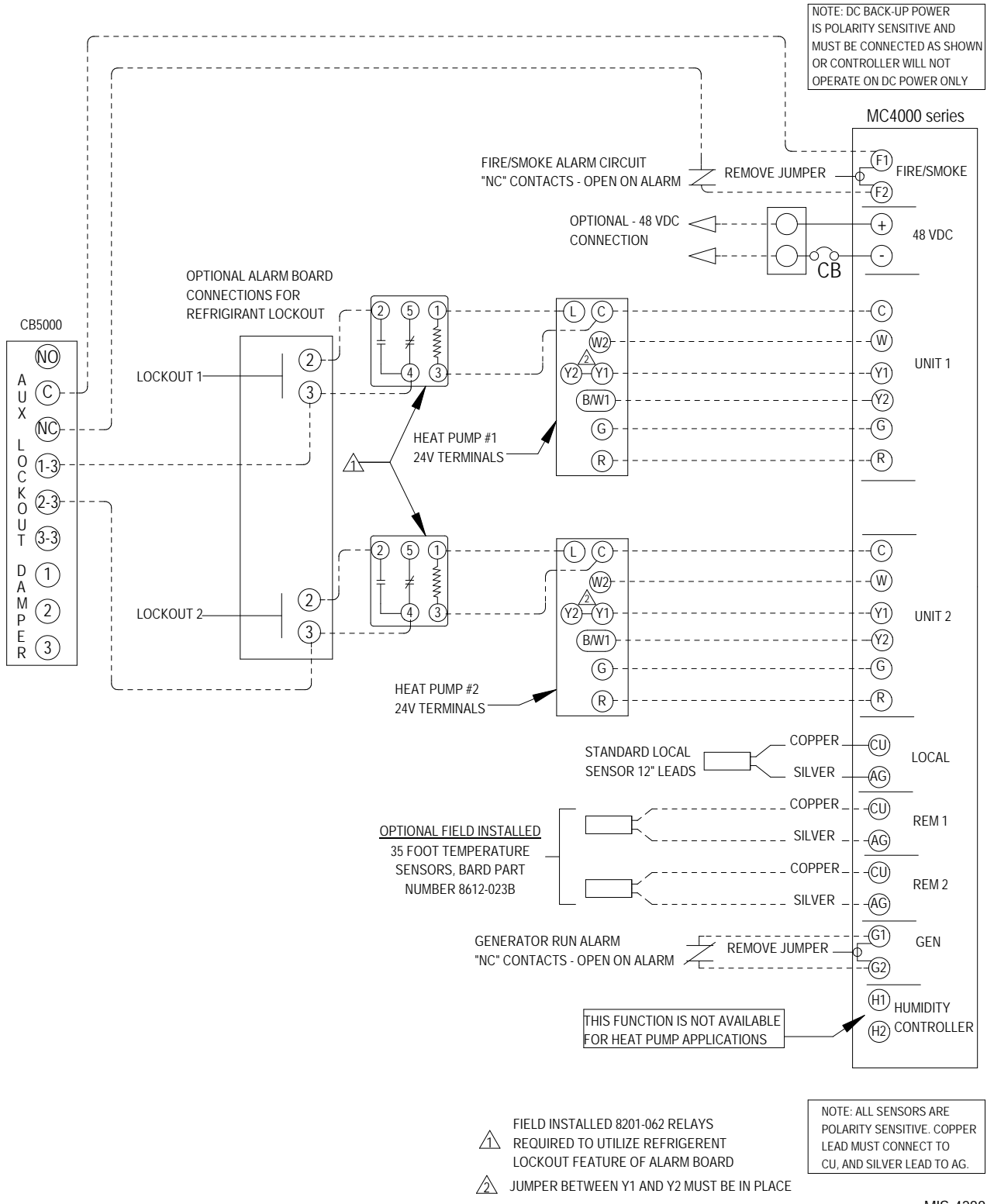

MIS-4288 A

CONTROLLER CONNECTIONS DIAGRAM 27

WH/W**H/SH/S**H Heat Pumps – No Economizers

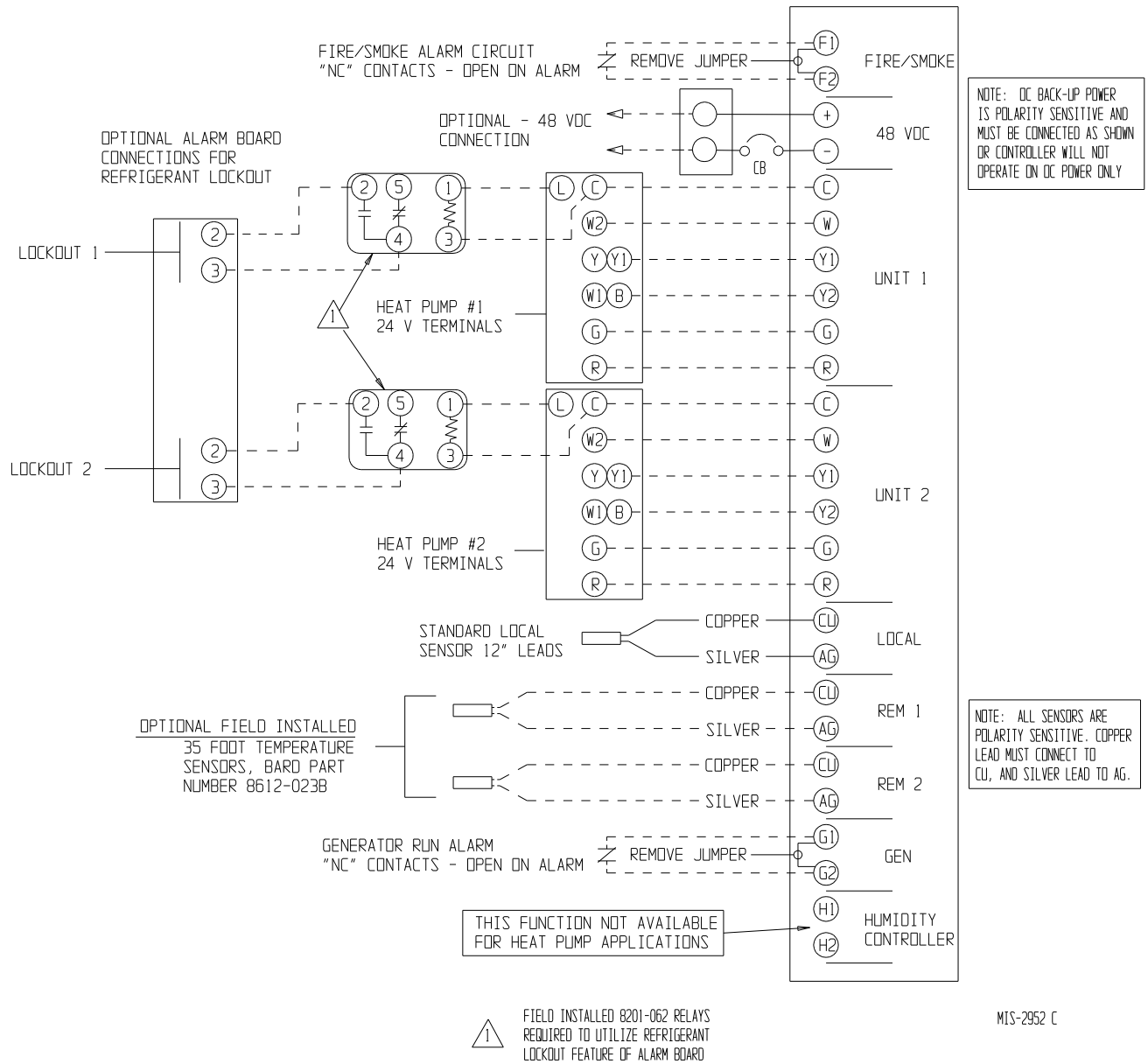

MIS-2952 C

CONTROLLER CONNECTIONS DIAGRAM 28

WH/W**H/SH/S**H Heat Pumps – No Economizers and with Alarm Board & CB5000 Series Communication Board

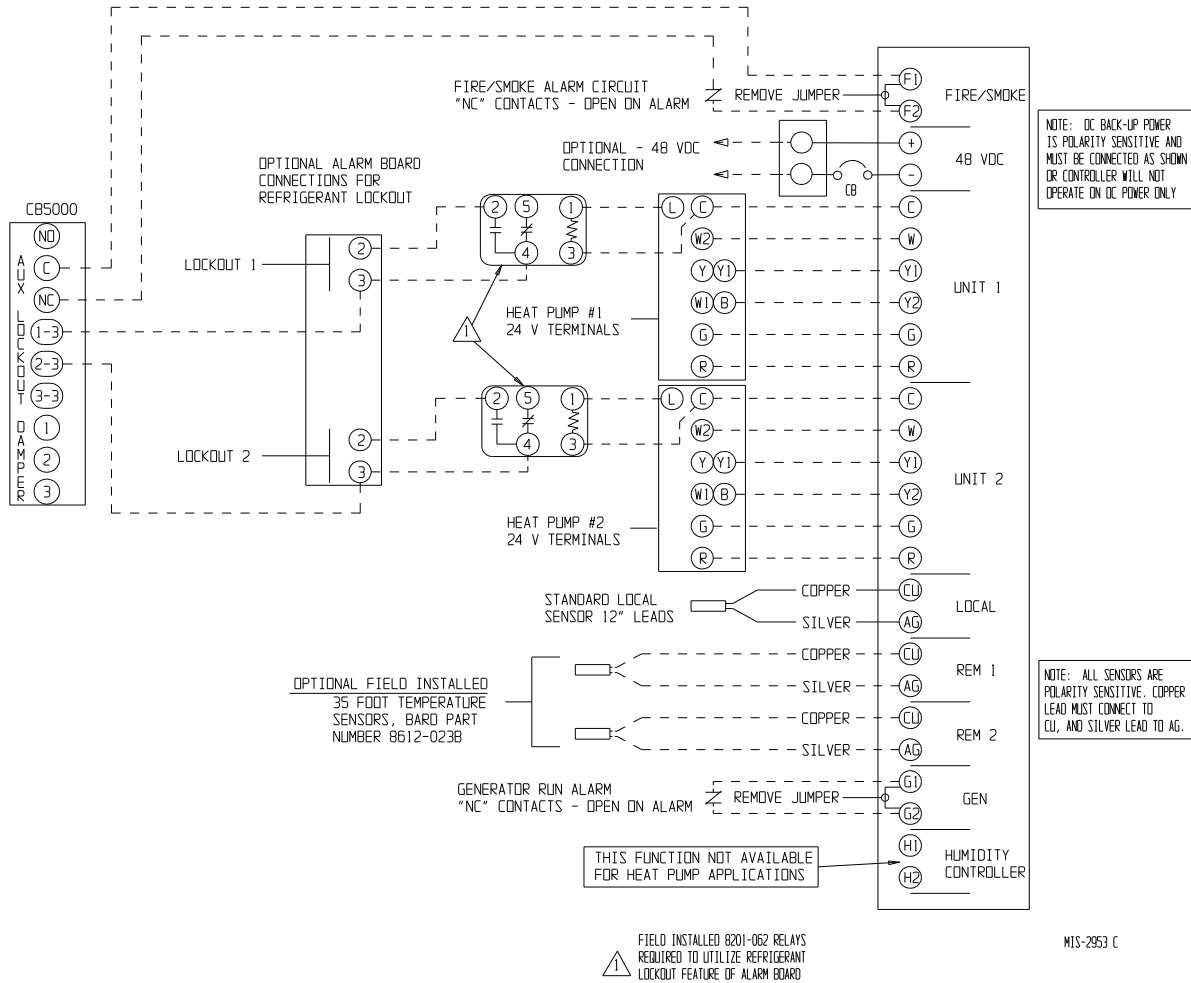

Single Unit Application for MC4002 with Alarm Board

When connecting an MC4002 with alarm board to a single unit, the unit must be wired to the Unit 1 position on the MC4002 board. A power loss alarm will appear for Unit 2. To eliminate this nuisance alarm, jumpers must be placed from Unit 1 "R" terminal to Unit 2 "R" terminal and Unit 1 "C" terminal to unit 2 "C" terminal on the control board (see Figure 21).

The control must be configured as follows: Number 8 "ALT" must be set to "NO"; Number 9 "LLCO" must be set to "O".

Wire the unit according to the correct diagram for the model being applied; see appropriate connection diagram.

CONTROLLER CONNECTIONS DIAGRAM 29

Single Unit with Alarm Board

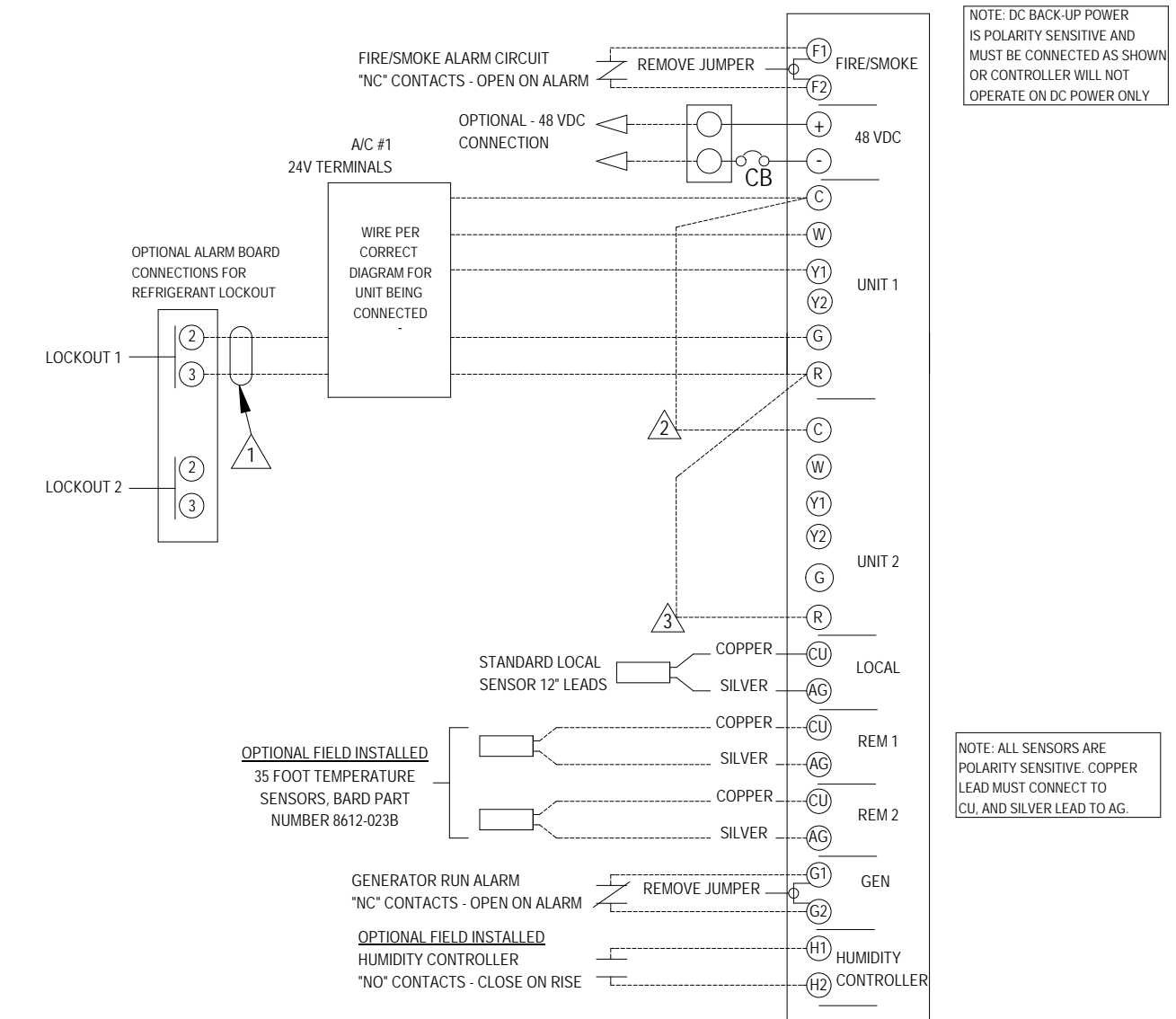

△ REQUIRES ALARM RELAY IN EACH A/C UNIT WHICH IS PART OF "J" CONTROL MODULE

△△ ADDED WIRES TO KEEP "UNIT 2 POWER LOSS" ALARM OFF

MIS-4303 A

ALARM WIRING

Alarm relays can be wired for NO (close on alarm) or NC (open on alarm) strategy.

Alarm relays can be used individually if there are enough available building alarm points, or can be arranged into smaller groups or even a single group so that all alarm capabilities can be utilized.

When multiple alarms are grouped together and issued as a single alarm, there will no off-site indication of which specific problem may have occurred, only that one of the alarms in the group has been triggered. The individual alarm problem will be shown on the LED display on the face of the controller.

NOTE: All alarm and output relays are Form C (SPDT) dry contacts rated 1A @ 24 VAC.

NOTE: All alarm relay outputs have 10-second delay in actually issuing to protect against nuisance alarm signals.

The Power Loss 1, Power Loss 2 and controller alarm relays are all “reverse actuated”, which means they are continuously energized (the NO contact is closed) and switched to NC position upon alarm condition. Therefore, it is important to closely follow the alarm board connection diagrams that follow.

Any alarm feature that is not desired can simply be ignored (not connected).

NOTE: The alarm LED display board is shipped uninstalled to protect it from possible damage during installation of the wiring to main controller board and/or the alarm board. It is polarity sensitive and is keyed so it can only be installed in correct position.

ALARM LED DISPLAY BOARD

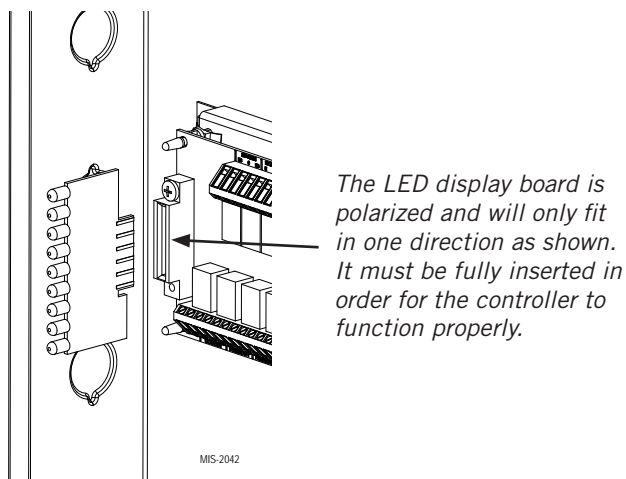

NOTE: The LED display board can be replaced if needed independently of the alarm board. Bard part number is 8612-022.

2ND STAGE COOLING ALARM

This alarm output is available for use if desired. It is important to note that in some installations, due to A/C system sizing and internal heat load, that the secondary (lag) air conditioning unit may be called upon to assist the lead air conditioner some of the time. If this is the case, or possibly when additional heat load is added, using the 2nd stage cooling alarm will cause nuisance alarm conditions.

NOTE: For units with 2-stage compressors, the dual stage cooling alarm activates on cooling Stage 3 initiation. Menu Step 23, CoPr, must be set to “2” for this to occur, otherwise alarm will activate on cooling call Stage 2 causing nuisance alarm.

For installations where it is known that there is 100% redundancy (one air conditioning unit can handle 100% of the load 100% of the time), use of the 2nd Stage Cooling Alarm is a method to issue an alarm signal that the lead air conditioner is down (or not delivering full capacity) and that the lag air conditioner is now operating.

REFRIGERANT PRESSURE ALARMS

Air conditioners with “J” control module are equipped with an alarm relay that is activated upon high or low refrigerant pressure lockout conditions. Connecting terminals 2 and 3 from the air conditioner 24V terminal block to the matching terminals 2 and 3 on the alarm board will allow these alarms to function.

EMERGENCY VENTILATION SEQUENCE

For units with economizers, there are two emergency ventilation sequences designed into the controller. Both require the -B alarm board and connection of terminals E and F from the alarm board to the specified terminals on the air conditioner 24V terminal block.

NOTE: The E and F wiring connections at the 24V terminal block in the A/C units are different for the older EIFM, ECONWM* and WECOP economizers than for newer economizers. Refer to the appropriate controller connection diagrams (see page 24).

Sequence one requires a refrigerant pressure alarm, coupled with high temperature alarm condition No. 1 (HAL 1 setpoint). If both of these conditions occur, the economizer in the air conditioner that issued the refrigerant alarm will drive open to ventilate the building.

Sequence two (HAL 2 setpoint) is activated by high temperature alarm No. 2 and will initiate even without a refrigerant pressure alarm signal. Both economizers will be activated to provide emergency ventilation. This strategy help protect against building overheating if air conditioner(s) are inoperative for non-pressure related reasons (bad compressor, contactor, run capacitor, etc.).

**FIGURE 3
ALARM BOARD CONNECTIONS
FOR NORMALLY CLOSED "NC" OPEN-ON-ALARM STRATEGY**

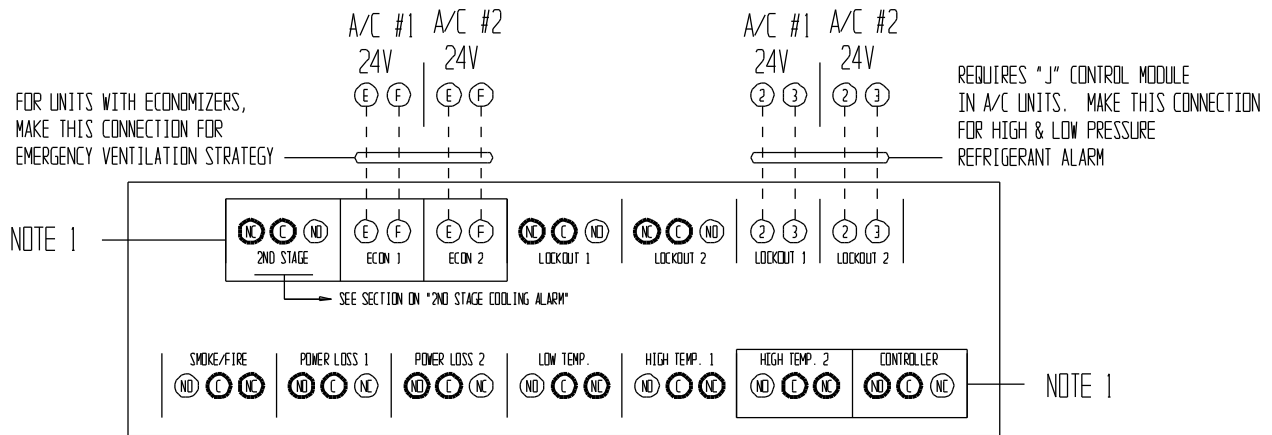

USE SHADED TERMINALS FOR DESIGNATED ALARMS AS DESIRED. SOME RELAYS ARE REVERSE ACTIVATED TO ACHIEVE "NC" OPEN-ON-ALARM SEQUENCE. EACH CAN BE USED INDIVIDUALLY IF THERE ARE ENOUGH BUILDING ALARM POINTS AVAILABLE OR CAN BE ARRANGED INTO SMALLER GROUPS OR EVEN A SINGLE GROUP SO THAT ALL ALARM CAPABILITIES CAN BE UTILIZED. FOR "NC" OPEN-ON-ALARM STRATEGY MULTIPLE ALARMS IN A GROUP ARE WIRED IN SERIES.

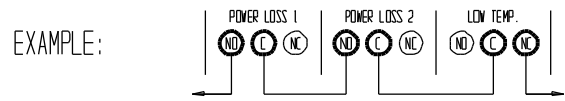

MIS-2014

NOTE 1: 2nd Stage, Econ 1, Econ 2, High Temp 2 and Controller alarms are only on -B alarm board. All other alarms are on both -A and -B alarm boards.

IMPORTANT: LED display board is shipped loose to protect it from possible damage during installation of the wiring to main controller board and/or the alarm board. It is polarity sensitive and is keyed so it can only be installed in correct position (see **ALARM LED DISPLAY BOARD** on page 54).

**FIGURE 4
ALARM BOARD CONNECTIONS
FOR NORMALLY OPEN "NO" CLOSE-ON-ALARM STRATEGY**

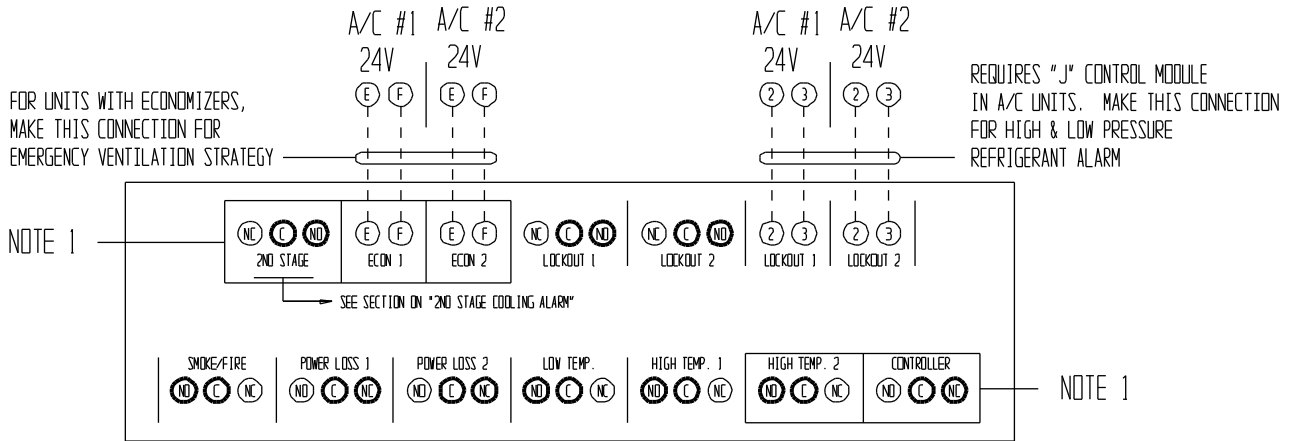

USE SHADED TERMINALS FOR DESIGNATED ALARMS AS DESIRED. SOME RELAYS ARE REVERSE ACTIVATED TO ACHIEVE "NO" CLOSE-ON-ALARM SEQUENCE. EACH CAN BE USED INDIVIDUALLY IF THERE ARE ENOUGH BUILDING ALARM POINTS AVAILABLE OR CAN BE ARRANGED INTO SMALLER GROUPS OR EVEN A SINGLE GROUP SO THAT ALL ALARM CAPABILITIES CAN BE UTILIZED. FOR "NO" CLOSE-ON-ALARM STRATEGY MULTIPLE ALARMS IN A GROUP ARE WIRED IN PARALLEL.

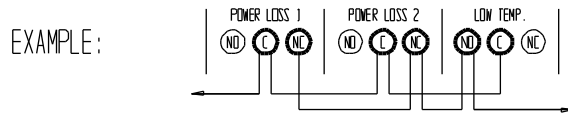

MIS-2015

NOTE 1: 2nd Stage, Econ 1, Econ 2, High Temp 2 and Controller alarms are only on -B alarm board. All other alarms are on both -A and -B alarm boards.

IMPORTANT: LED display board is shipped loose to protect it from possible damage during installation of the wiring to main controller board and/or the alarm board. It is polarity sensitive and is keyed so it can only be installed in correct position (see **ALARM LED DISPLAY BOARD** on page 54).

PROGRAMMING INSTRUCTIONS

To swap lead and lag unit positions, press the ADVANCE button.

To enter the Program mode, press the PROGRAM button and release it when the message PROG appears on the display. When in Program mode, the DOWN and UP arrows are used to scroll through the programming steps.

A FLASHING display means that the function or choice is "SET", and the display will alternate between the step function and setting.

To change the setting of any step, press the CHANGE button and the display will stop flashing, allowing change to the setting by using the DOWN or UP arrows. When desired setting is reached, press the SAVE button, and proceed as desired. When done with programming changes, press the PROGRAM button until display stops flashing and room temperature display is shown. If no buttons are pushed within 30 seconds, the controller will automatically revert back to "RUN" mode.

To reset all controller settings to the factory default values, press the PROGRAM button for 10 seconds until display reads dEF.

NOTE: When the controller has the security locking feature enabled, no changes to any selectable features can be made and the default reset feature is also locked out. All of the programmable features/settings can be reviewed using the Program button and Up or Down arrows, but any attempt to change settings using the Change button will result in display showing "Locd" indicating controller is locked. See **Security (Locking) Feature** on page 23.

See next page for Programmable Features, Default Settings and MC4002 front panel label layout.

NOTE: When using the controller buttons to review settings or making changes, ***push and hold*** the buttons for approximately 1 second or until the display changes. Quickly pushing or jabbing the buttons will not allow the controller to respond.

MC Series

Solid State Dual Unit Lead/Lag Controller

Alarms

Alarm boards are optional and can be factory or field installed. See inside of controller for any alarm functions.

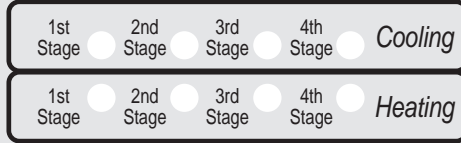
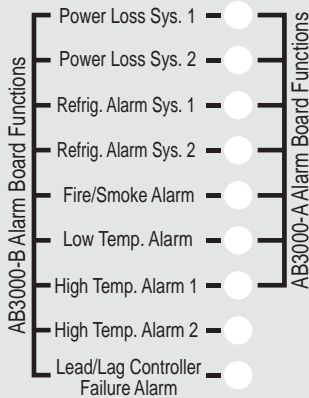

Digital Display

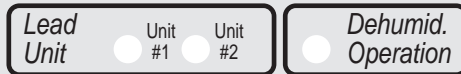

Operating Instructions

- To swap lead and lag units press "ADVANCE".
- To enter the Program mode press the "Program" button and release it when "Pro9" appears. Use "DOWN" or "UP" arrows to scroll through menu.
- A "Flashing" display means that the function or choice is "Set", and the display will alternate between the step function and setting.
- To change the setting of any step press the "Change" button and the display will stop flashing, allowing change to the setting by using the "Down" or "Up" arrows. When desired setting is reached press the "Save" button, and proceed as desired.
- When done programming press the "Program" button until display stops flashing and room temperature is shown. If no buttons are pushed within 30-seconds the controller will automatically revert back to "Run" mode.

Comfort Mode

Press "Comfort" button once to reset to 72F/22C Cooling and 68F/20C Heating for 1-hour. Display will flash during override period. Press 2nd-time to cancel during override if desired, or controller will automatically revert to selected SP after 1-hour.

Program Menu

NOTE: Push and hold Up or Down arrows for 1-second until display blanks to move between steps.

1	LSEn	Temperature at local (main) Sensor	
2	r 1	Temperature at Remote 1 sensor location*	
3	r 2	Temperature at Remote 2 sensor location*	
4	SP	Cooling setpoint temperature (65 to 90F or 18.3 to 32.2C - Default is 77F/25C)	
5	db	Deadband between cooling and heating setpoint (2 to 40F or 1.1 to 22.2C - Default is 17F/9.4C)	
6	cFRn	Continuous blower operation (None, Lead, Both - Default is None)	
7	dES	Degree display (F or C - Default is F)	
8	ALT	Alternating Lead-Lag-Lead-Lag Sequence or Non-Alternating Lead-Lead-Lag-Lag Sequence (Yes or No - Default is Yes for Alternating)	
9	LLCO	Lead-Lag changeover time (Days) (1 to 30 days, or 0 for disabled - Default is 7)	
10	HP	Heat pump logic enabled - only for 1-stage heat pumps and forces Lead-Lag sequence and overrides a Non-Alt setting (Yes or No - Default is No)	
11	cbds	Unit 1 and 2 blowers automatically both run if delta T > 5F between any 2 connected sensors (Yes or No - Default is Yes)	
12	DFdE	3-minute lead unit & 4-minute lag unit off-delay enabled	(Yes or No - Default is No)
13	crun	Minimum of 3-minute compressor runtime enabled	(Yes or No - Default is No)
14	LoAL	Low temperature alarm setpoint	(28 to 65F or 21.1 to 48.8C - Default is 45F/7.2C)
15	HRL 1	High temperature alarm Level 1 setpoint	(70F to 120F or 21.1 to 48.8C - Default is 90F/32.2C)
16	HRL 2	High temperature alarm Level 2 setpoint	(70F to 120F or 21.1 to 49C - Default is 95F/35C)
17	ISd2	Inter-stage differential from Stage 1 to 2	(2, 3, 4, 5 or 6F - Default is 4)
18	ISd3	Inter-stage differential from Stage 2 to 3	(2 or 3F - Default is 2)
19	ISd4	Inter-stage differential from Stage 3 to Stage 4	(2 or 3F - Default is 2)
20	CSon	Turn "On" above SP for Stage 1 Cooling	(+1 or +2 - Default is +2)
21	CSoF	Turn "Off" below SP for Stage 1 Cooling	(-1, -2, -3, or -4F - Default is -2) Note: For CSon and CSoF Stage 2, 3 and 4 Cooling are automatically same as Stage 1
22	HSoo	All Heating stages are equal -/+ On & Off differential	(-1/+1 or -2/+2 - Default is -2/+2)
23	CoPr	1 or 2-stage compressor, if set to 1 the 2nd-Stage Cooling Alarm activates on Cooling Call 2 If set to 2 the 2nd-Stage Cooling Alarm activates on Cooling Call 3.	(1 or 2 - Default is 1)
24	Locd	Controller is Locked. Consult building authority for further instructions.	

FIGURE 3
PARTS LIST DESCRIPTION DIAGRAM

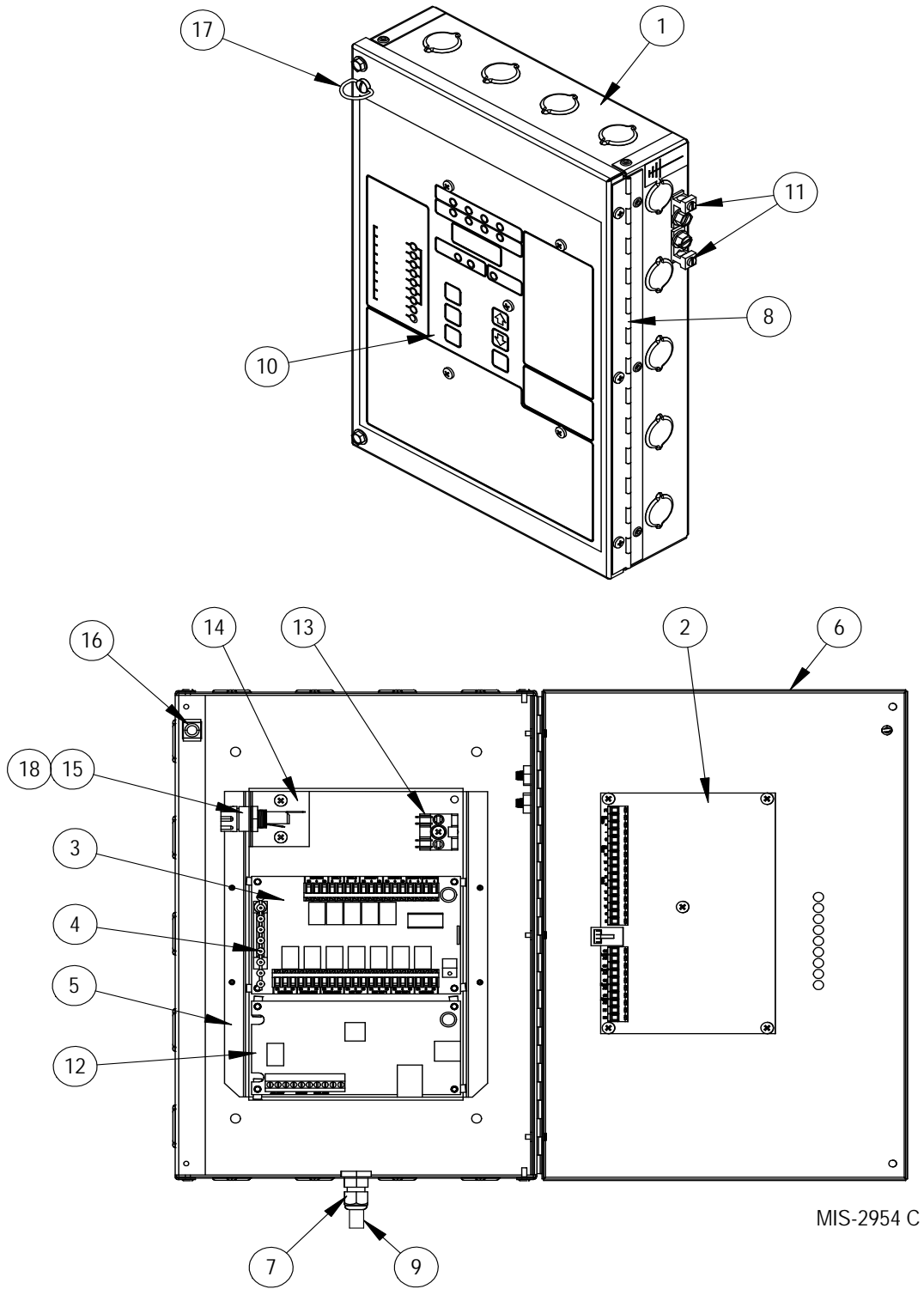

Parts list on following page

Parts List

Dwg. No.	Part No.	Description	MC4002	MC4002-A	MC4002-AC	MC4002-B	MC4002-BC	AB3000-A	AB3000-B	CB5000 Series
1	127-343-4	Control Box	X	X	X	X	X			
2	8612-043	Controller Board	X	X	X	X	X			
3	8612-049	Alarm Board A*		X	X			X		
3	8612-050	Alarm Board B*				X	X		X	
4	8612-022	Alarm Display		X	X	X	X	X	X	
5	113-430-4	Support Bracket	X	X	X	X	X			
6	152-625-4	Control Box Door	X	X	X	X	X			
7	8611-099	LTF Fitting	X	X	X	X	X			
8	5400-002	Hinge	X	X	X	X	X			
9	8612-023B	Sensor	X	X	X	X	X			
10	7961-731	Label/Keypad	X	X	X	X	X			
11	8611-006	Ground Lug	2	2	2	2	2			
12	8612-047	Communication Board			X		X			X
13	8607-030	Terminal Block	X	X	X	X	X			
14	113-588	Fuse Bracket	X	X	X	X	X			
15	8614-056	Fuse Holder	X	X	X	X	X			
16	1171-023	1/4 Turn Receptacle	X	X	X	X	X			
17	1171-022	1/4 Turn Fastener	X	X	X	X	X			
18	8614-057	Fuse	X	X	X	X	X			
NS	8612-039	Communication Cable			X		X			X
NS	8612-051	Alarm Board Cable		X	X	X	X	X	X	
NS	8301-103	Board Standoff	4	4	4	4	4			4

* 8612-051 alarm board cable included with these alarm boards

NS – Not Shown

TABLE 2
Temperature Sensor Table

Value measured at sensor connections to the main controller board with controller powered up

F	Kelvin	VDC	F	Kelvin	VDC
60	288.7056	2.887	83	301.4822	3.015
61	289.2611	2.893	84	302.0377	3.020
62	289.8167	2.898	85	302.5932	3.026
63	290.3722	2.904	86	303.1487	3.031
64	290.9277	2.909	87	303.7042	3.037
65	291.4832	2.915	88	304.2597	3.043
66	292.0387	2.920	89	304.8152	3.048
67	292.5942	2.926	90	305.3707	3.054
68	293.1497	2.931	91	305.9262	3.059
69	293.7052	2.937	92	306.4817	3.065
70	294.2607	2.943	93	307.0372	3.070
71	294.8162	2.948	94	307.5927	3.076
72	295.3717	2.954	95	308.1482	3.081
73	295.9272	2.959	96	308.7037	3.087
74	296.4827	2.965	97	309.2592	3.093
75	297.0382	2.970	98	309.8147	3.098
76	297.5937	2.976	99	310.3702	3.104
77	298.1492	2.981	100	310.9257	3.109
78	298.7047	2.987	101	311.4812	3.115
79	299.2602	2.993	102	312.0367	3.120
80	299.8157	2.998	103	312.5922	3.126
81	300.3712	3.004	104	313.1477	3.131
82	300.9267	3.009	105	313.7032	3.137

NOTES

1. If sensor is connected in reverse (copper wire to AG terminal and silver wire to CU terminal), the voltage across the two terminals will measure approximately .7vDC. Controller must be "On".
2. If sensor connected with reverse polarity, the display should read 00.
3. Cannot check sensor by disconnecting leads and measuring ohms, but ohmmeter can be used to check for bad sensor (infinity would = open and continuity = shorted).
4. If sensor is open or lead broken/disconnected, the display will show the setpoint.
5. If sensor appears to be OK, try reconnecting to either R1 or R2 input terminals. If controller now works OK, something wrong with "Loc" input circuit. OK to leave this way.
6. If more than one sensor is connected and one fails, the controller will operate OK from the functional sensor.
7. If only one sensor and it fails or is disconnected, 1st stage cooling will default "On" if it was calling for cooling when sensor went out. If additional stages were on at the time, they will turn off.