INSTALLATION INSTRUCTIONS

Two Stage Heat Pump Low Voltage Control Circuit Wiring

Heat Pump Models:

T**S T**S*D C**H

Ventilation Packages:

CRVP-3	CHCRV-5	ERVF-A3
CRVS-3	CHCRV-5A	ERVF-C3
CRVS-3A		ERVF-A5
CRVP-5		ERVF-C5
CRVS-5		
CRVS-5A		



Climate Control Solutions

Bard Manufacturing Company, Inc.
Bryan, Ohio 43506
www.bardhvac.com

Manual: 2100-554K
Supersedes: 2100-554J
Date: 4-4-23

CONTENTS

Installation

Low Voltage Wiring	3
--------------------------	---

Figures

Figure 1 HP w/Opt. Elec. Heat No Economizer or Vent. Pkgs.	5
Figure 2 HP w/Opt. MFAD, CRVS-*, CRVP-* or ERV Vent. Pkg. w/Programmable T-Stat ...	6
Figure 3 HP w/Opt. Economizer	7
Figure 4 HP w/Dehumidification Sequence & No Vent Pkg. Using T-Stat #8403-060 Combination Temp. & Humidity Control	8
Figure 5 HP w/Dehumidification Sequence & Opt. MFAD, CRVS-*, CRVP-* or ERV Vent Pkg. Using Elec.T-Stat w/Combination Temp. & Humidity Control with Optional CO ₂ Controller	9
Figure 6 Dehumidification HP with Opt. Economizer	10
Figure 7 2 Stage HP w/Opt. Elec. Heat w/ ECONWM* Style Economizer.....	11
Figure 8 2 Stage HP w/Dehumidification & Opt. Elec. Heat w/ECONWM* Style Economizer	12
Figure 9 2 Stage HP w/CHCRV-5 or CRVMWH-3 Vent Option Pkg. w/Prog. T-Stat w/Opt. On/Off CO ₂ Controller	13
Figure 10 2 Stage HP w/CHCRV-5 or CRVMWH-3 Vent Option Pkg. w/Prog. T-Stat w/Opt. Modulating CO ₂ Controller.....	14
Figure 11 HP w/Opt. CRVS-*A or CHCRV-5A Vent. Pkg. w/Programmable Thermostat, with or without Optional CO ₂ Controller	15
Figure 12 HP w/Opt. CRVS-*A or CHCRV-5A Vent. Pkg. w/Thermostat (No Occupied Signal), with or without Optional CO ₂ Controller..	16
Figure 13 HP w/Dehumidification Sequence & Opt. CRVS-*A Vent. Pkg. Using Elec. T-Stat with Combination Temp. & Humidity Control with Optional CO ₂ Controller	17
Figure 14 HP w/Dehumidification Sequence & Opt. CRVS-*A Vent. Pkg. Using T-Stat (No Occupied Signal), with or without Optional CO ₂ Controller.....	18

Tables

Table 1 Diagram to Use w/Unit and Vents.....	3
Table 2 Operating Voltage Range.....	3
Table 3 Wall Thermostat.....	4
Table 4 Humidity Controls	4
Table 5 CO ₂ Controller.....	4
Table 6 Thermostat Wire Size.....	4

TABLE 1
Diagram to Use With Unit and Vents

Model Series	Vent	None	CRVS-*, CRVP-*, ERV, MFAD	CRVMWH-3, CHCRV-5	Economizer "E" Vent Option	T, W, S ECONWMT	CRVS-3A, CRVS-5A		CHCRV-5A	
	Vent Code	X	R, M, V, P	C	E	T, W, S	V		C	
	Programmable Thermostat	--	--	--	--	--	No	Yes	No	Yes
T**S C**H	--	1	2	9,10	3	7	12	11	12	11
T**S*D	--	4	5	9,10	6	8	14	13	N/A	N/A

Low Voltage Wiring

230/208V, 1 phase and 3 phase equipment dual primary voltage transformers. All equipment leaves the factory wired on 240V tap. For 208V operation, reconnect from 240V to 208V tap. The acceptable operating voltage range for the 240V and 208V taps are:

TABLE 2
Operating Voltage Range

Tap	Range
240V	253 - 216
208V	215 - 187

NOTE: The voltage should be measured at the field power connection point in the unit and while the unit is operating at full load (maximum amperage operating condition).

An 18 gauge copper, color-coded thermostat cable is recommended. The connection points are shown in Table 2.

Low Voltage Connection

These units use a grounded 24-volt AC low voltage circuit.

The "R" terminal is the *hot* terminal and the "C" terminal is *grounded*.

"G" terminal is the *fan input*.

"Y" terminal is the *compressor input* Stage 1.

"B" terminal is the *reversing valve input*. The reversing valve must be energized for heating mode.

"R" terminal is the *24 VAC hot*.

"RT" terminal is the *24 VAC hot from transformer* (used with "R" for fire/smoke shutdown).

"C" terminal is the *24 VAC grounded*.

"Y1" terminal is the *compressor input* Stage 2.

"L" terminal is *compressor lockout output*. This terminal is activated on a high or low pressure trip by the electronic heat pump control. This is a 24 VAC output.

"W2" terminal is *second stage heat* (if equipped).

"O1" terminal is the *ventilation input*. This terminal energizes any factory installed ventilation option.

"E" terminal is the *emergency heat input*. This terminal energizes the emergency heat relay.

"W3" terminal is the *dehumidification input*. This terminal energizes compressor, blower and three-way valve. This applies only to models equipped for dehumidification sequence.

LOW VOLTAGE CONNECTIONS FOR DDC CONTROL

Fan Only	Energize G
Cooling Mode 1 st Stage	Energize Y, G
Cooling Mode 2 nd Stage	Energize Y, Y1, G
Heat Pump Heating 1 st Stage	Energize Y, G, B
Heat Pump Heating 2 nd Stage	Energize Y, Y1, B, G
3 rd Stage Heating w/Heat Pump (if employed)	Energize G, W2, Y, B, Y1
Ventilation	Energize G, O1
Emergency Heat	Energize B, W2, E, G
Dehumidification	Energize W3

TABLE 3
Wall Thermostat

Part Number	Predominate Features
8403-058 (TH5220D1151) <i>No Longer Available</i>	2 stage Cool, 2 stage Heat - Conventional 1 stage Cool, 2 stage Heat - Heat Pump Electronic Non-Programmable Auto or Manual changeover
8403-060 (1120-445)	3 stage Cool; 3 stage Heat HP or Conventional Auto or Manual changeover Dehumidification Output
8403-090 (T6 Pro) 8403-092 (T6 Pro w/Wi-Fi)	2 stage Cool, 2 stage Heat - Conventional 2 stage Cool, 3 stage Heat - Heat Pump Programmable/Non-Programmable Electronic Auto or Manual changeover

TABLE 4
Humidity Controls

Part Number	Predominate Features
8403-100* (H6062A1000)	Electronic humidistat DPST Humidity range 10-90% with adjustable stops
8403-047 (H200-10-21-10)	Electronic dehumidistat SPST closes-on-rise Humidity range 10-90% with adjustable stops

* If using Honeywell HumidiPRO (H6062A1000) 8403-100 humidistat, it must be configured for dehumidification in the menu.

TABLE 5
CO₂ Controller

Part Number	Predominate Features
8403-067 <i>No Longer Available</i>	Normally Open SPST relay closes-on-rise 24V dual wave length sensor. Default setting 950ppm, adjustable to 0-2000ppm Default off setting 1000ppm, adjustable to 0-200 ppm can be calibrated
8403-096	Normally Open SPST relay closes-on-rise 24V dual wave length sensor with 0-10V output. Default relay setting 1000ppm, adjustable to 0-2000/5000ppm. Default relay-off setting 950ppm, adjustable to 0-2000/5000ppm can be calibrated. 0-10V low-output range set to 0ppm, adjustable to 0-2000/5000ppm. 0-10V high-output range set to 2000/5000ppm, adjustable to 0-2000/5000ppm.

TABLE 6
Thermostat Wire Size

Transformer VA	FLA	Wire Gauge	Maximum Distance in Feet
55	2.3	18 gauge	60
		16 gauge	100
		14 gauge	160
		12 gauge	250

FIGURE 1
Low Voltage Wiring Diagram:
Heat Pump With Optional Electric Heat
No Economizer or Ventilation Packages

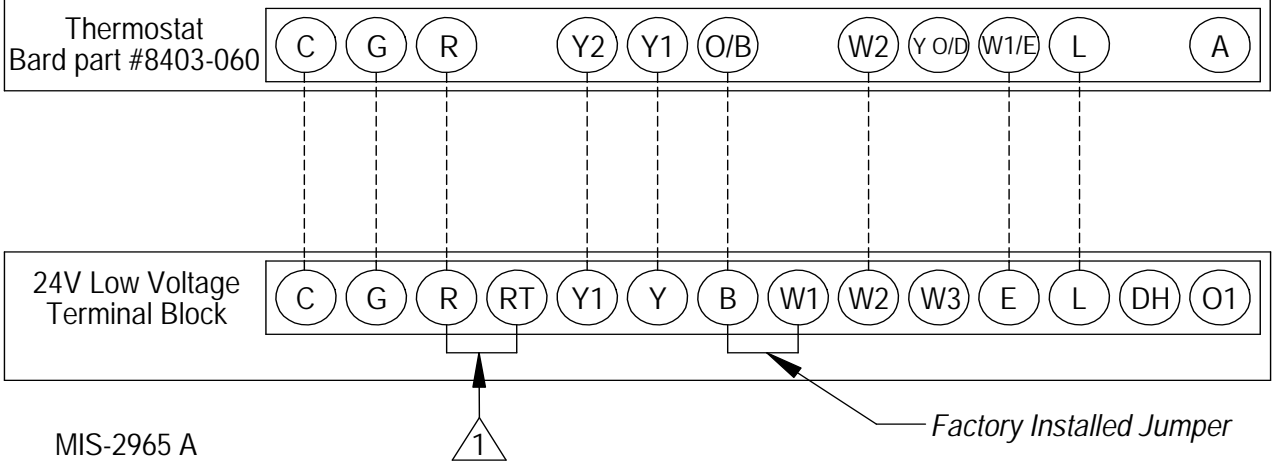

 *Factory installed jumper (on applicable models). Remove jumper and connect to N.C fire alarm circuit if emergency shutdown required.*

FIGURE 2
Low Voltage Wiring Diagram:
Heat Pump With Optional MFAD, CRVS-*, CRVP-* or ERV Ventilation Package With Programmable Thermostat
*For CRVS-*A information, refer to Figure 11 on page 15.*



MIS-2966 F

FIGURE 3
Low Voltage Wiring Diagram:
Heat Pump With Optional Economizer

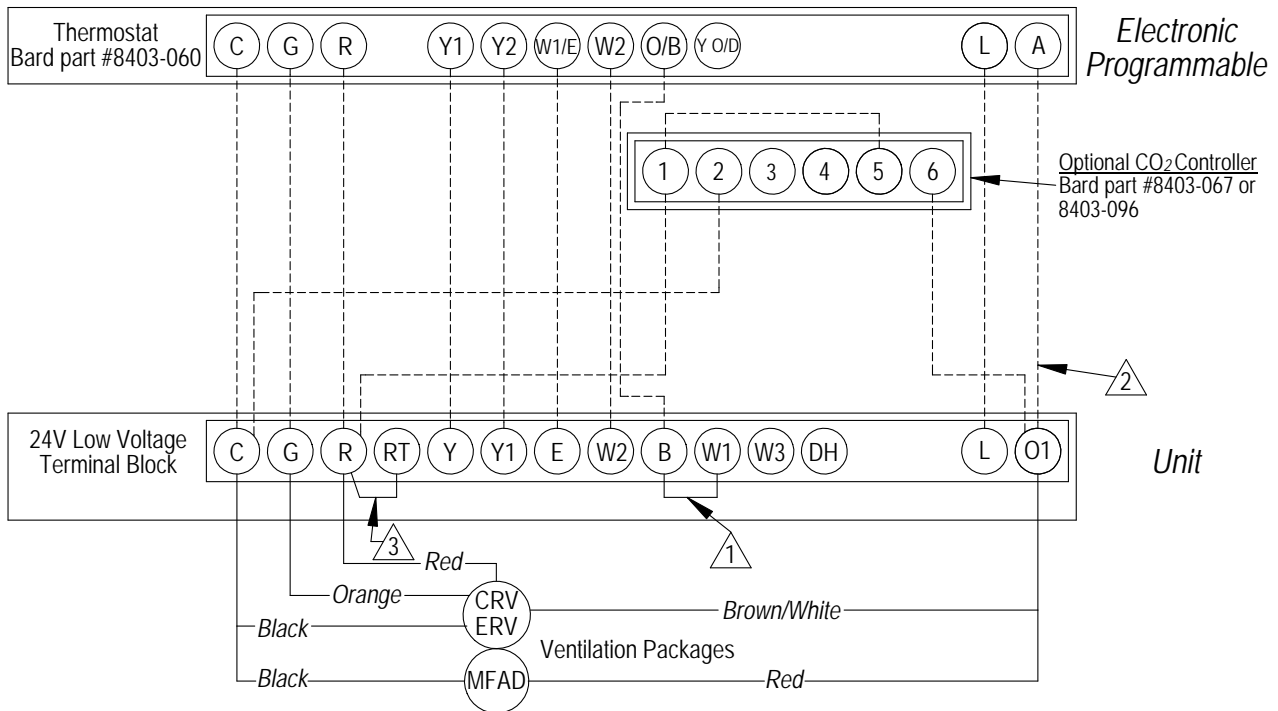
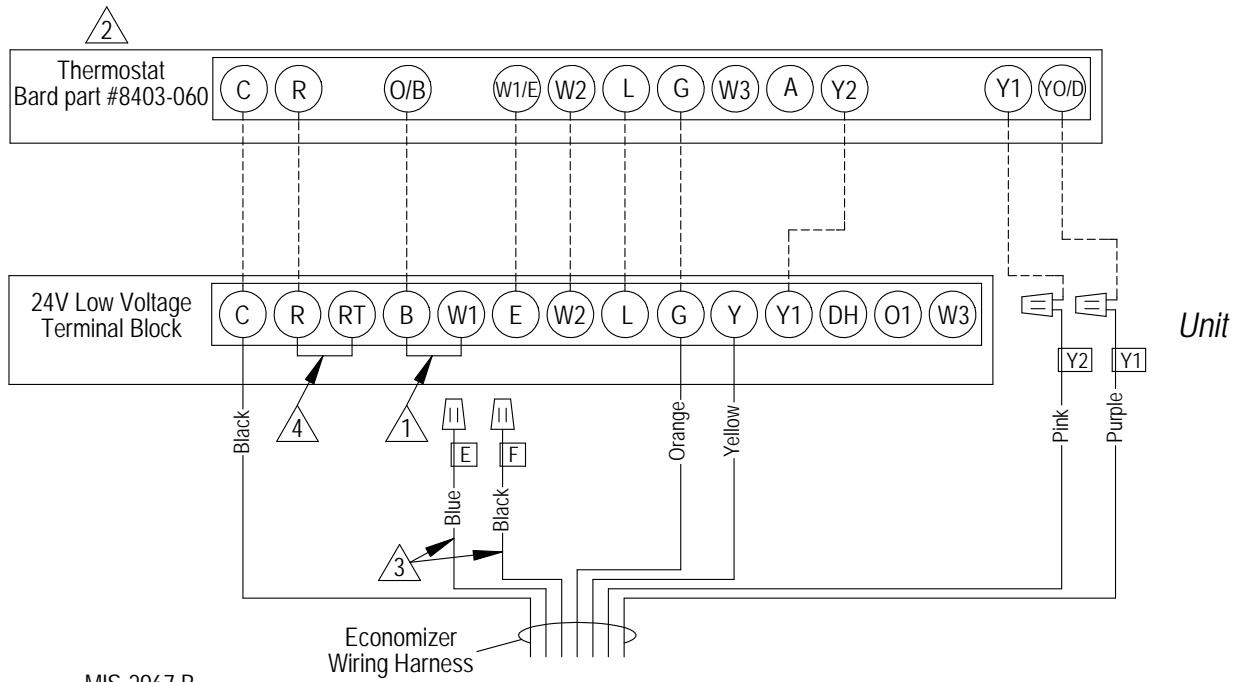

MIS-2967 B

- ⚠️ 1 Factory Jumper Installed.
- ⚠️ 2 Must be configured for economizer with YO/D output to be active as first stage cooling.
- ⚠️ 3 These wires are used in special control applications only.
- ⚠️ 4 Factory installed jumper (on applicable models). Remove jumper and connect to N.C fire alarm circuit if emergency shutdown required.

FIGURE 4
Low Voltage Wiring Diagram:
Heat Pump With Dehumidification Sequence and No Ventilation Package
Using Thermostat #8403-060 Combination Temperature & Humidity Controller

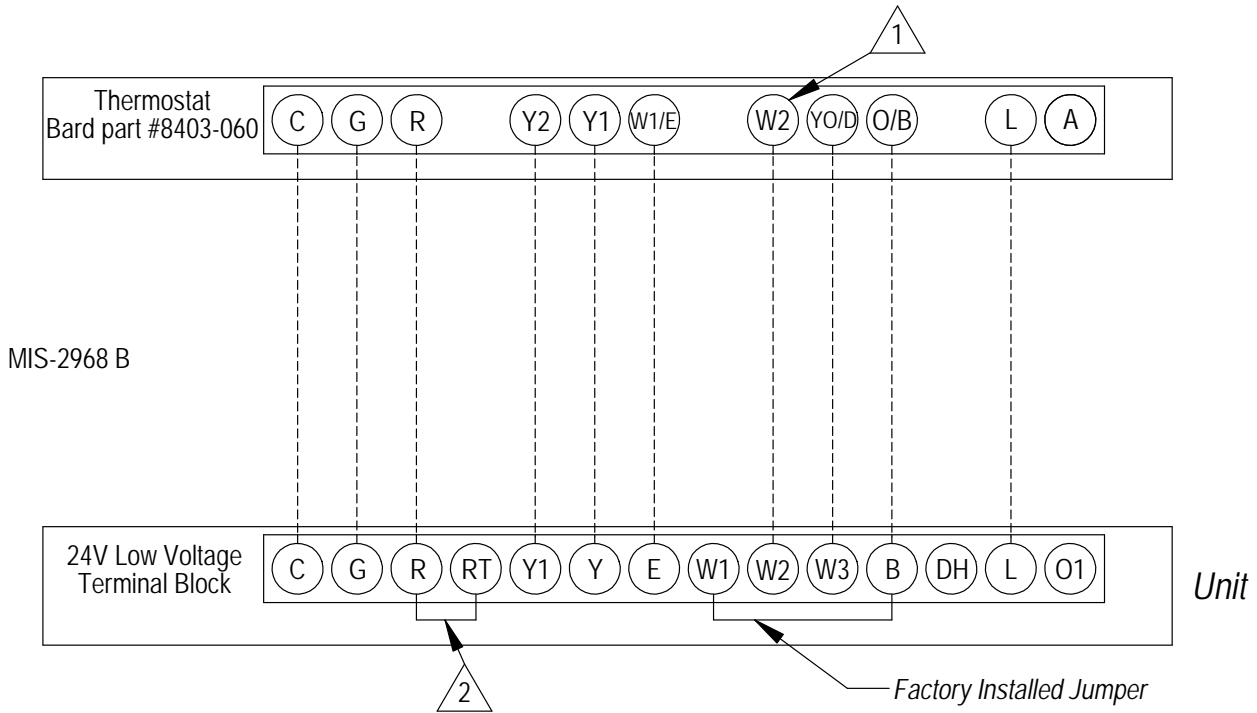

1 Must be configured for "no economizer" to make YO/D output active for humidity control.

2 Factory installed jumper (on applicable models). Remove jumper and connect to N.C fire alarm circuit if emergency shutdown required.

FIGURE 5
Low Voltage Wiring Diagram:
Heat Pump With Dehumidification Sequence & Optional MFAD, CRVS-*, CRVP-* or ERV Ventilation
Package Using Electronic Thermostat With Combination Temperature & Humidity Control
With Optional CO₂ Controller

*For CRVS-*A information, refer to Figure 13 on page 17.*

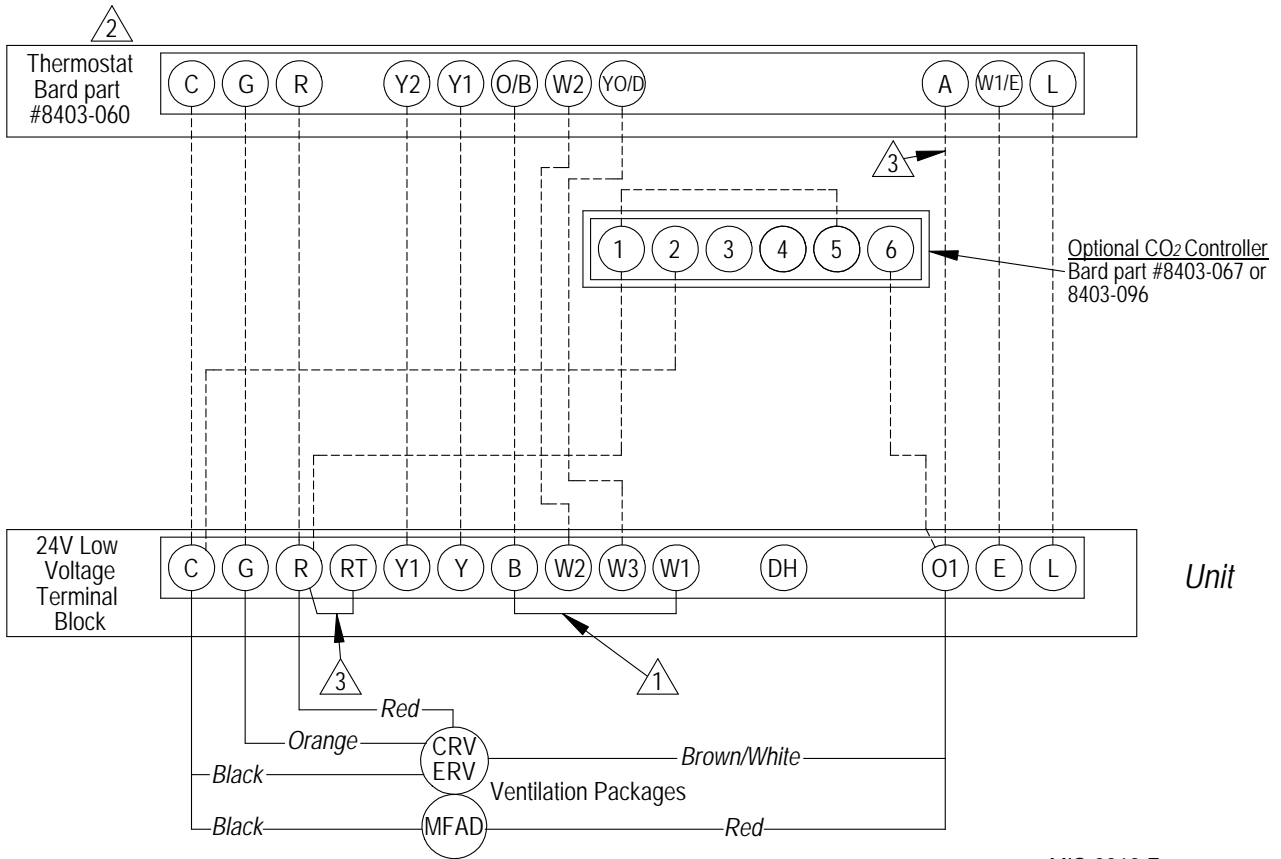

- △1 Factory Jumper Installed
- △2 Must be configured for "no economizer" to make YO/D output active for humidity control.
- △3 Factory installed jumper (on applicable models). Remove jumper and connect to N.C fire alarm circuit if emergency shutdown required.

MIS-2969 E

FIGURE 6
Low Voltage Wiring Diagram:
Dehumidification Heat Pump With Optional Economizer

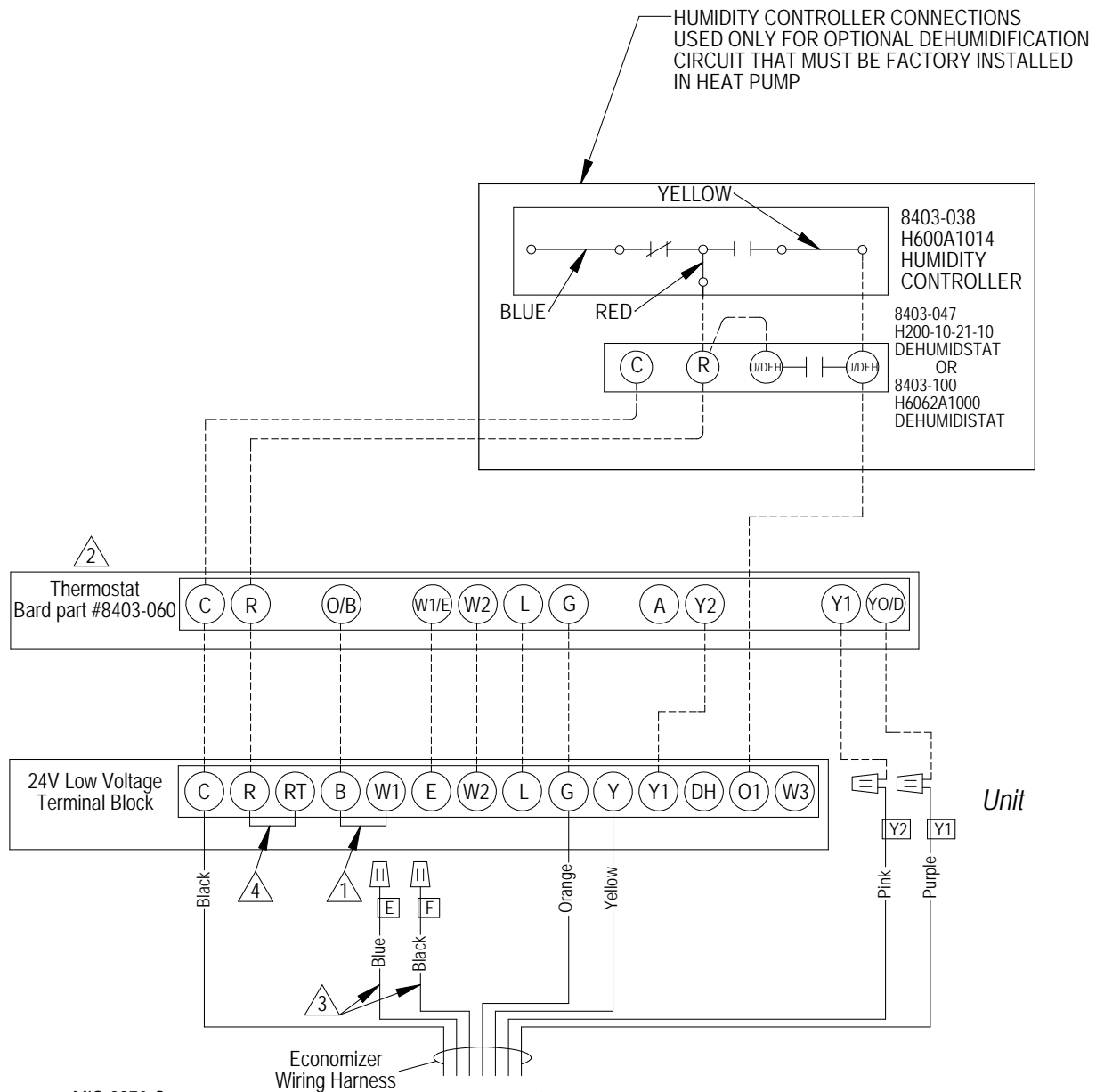

MIS-2970 C

- 1 Factory Jumper Installed.
- 2 Must be configured for economizer with YO/D output to be active as first stage cooling.
- 3 These wires are used in special control applications only.
- 4 Factory installed jumper (on applicable models). Remove jumper and connect to N.C fire alarm circuit if emergency shutdown required.
- 5 Humidistat 8403-100 will need to be configured for dehumidification in the menu. see user's manual.

FIGURE 7
Low Voltage Wiring Diagram:
2 Stage Heat Pump With Optional Electric Heat With ECONWM* Style Economizer

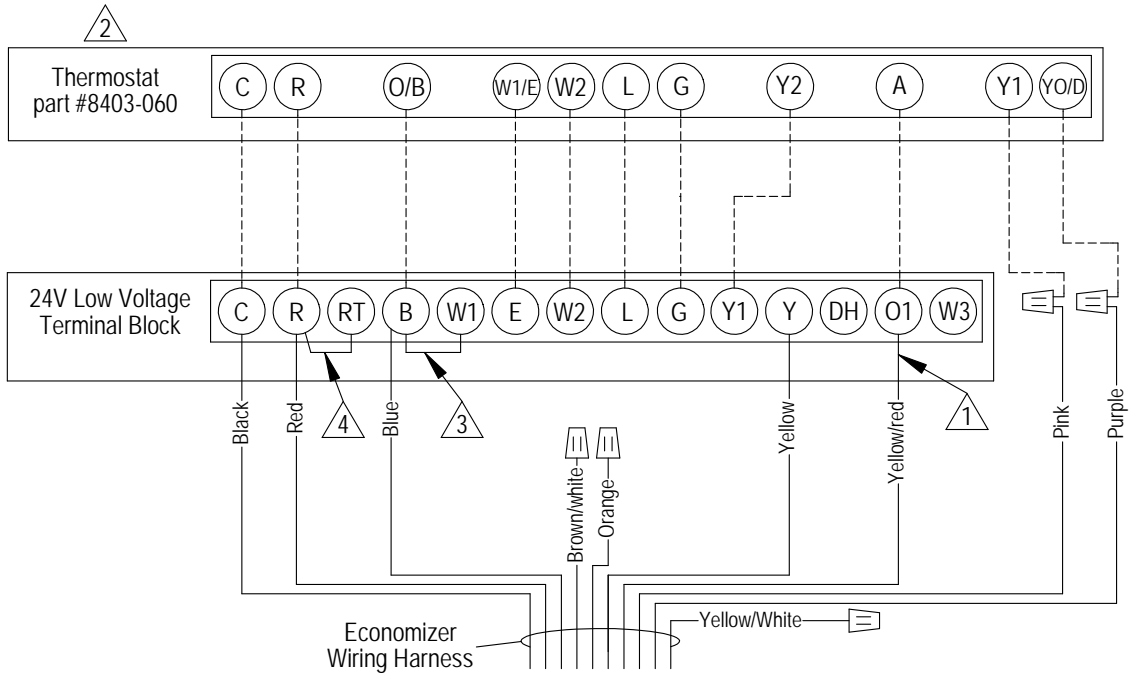

- ⚠️ **1** Must be energized to enable minimum position. NOTE: Economizer Control Default Setting is 10V (100%). Depending upon application may require setting to lower value.
- ⚠️ **2** Must be configured for heat pump and economizer to enable YO/D output to be active as 1st-stage cooling
- ⚠️ **3** Factory Jumper Installed.
- ⚠️ **4** Factory installed jumper (on applicable models). Remove jumper and connect to N.C fire alarm circuit if emergency shutdown required.

MIS-2982 C

FIGURE 8
Low Voltage Wiring Diagram:
2 Stage Heat Pump With Dehumidification & Optional Electric Heat With ECONWM* Style Economizer

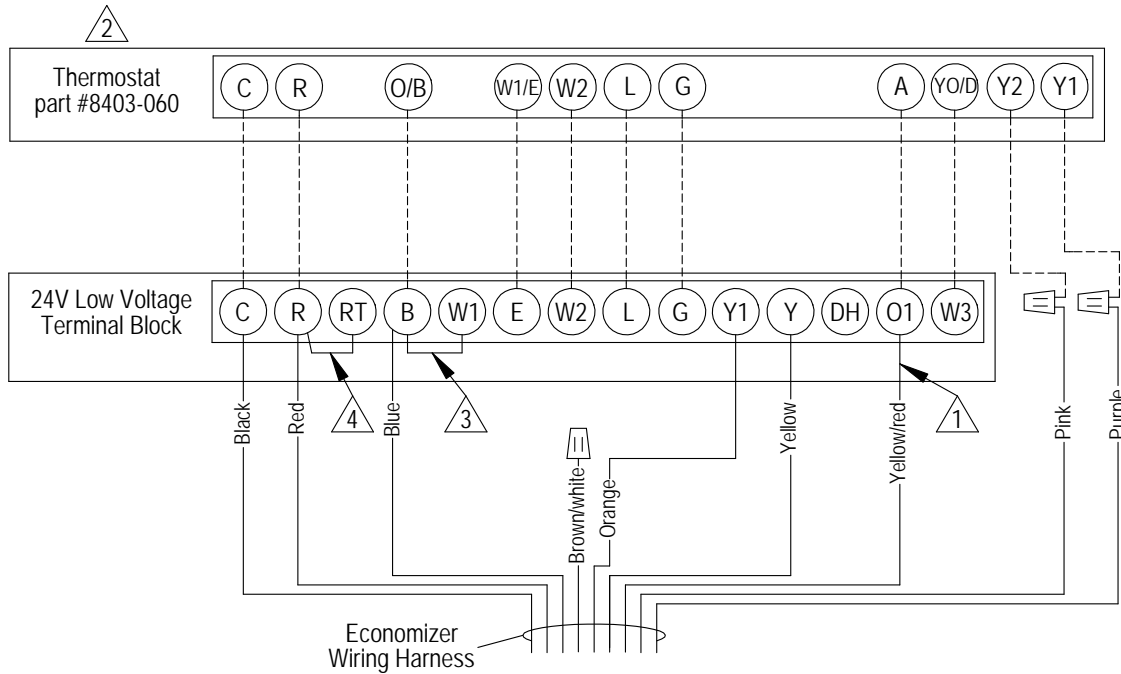

- △ 1 Must be energized to enable minimum position. NOTE: Economizer Control Default Setting is 10V (100%). Depending upon application may require setting to lower value.
- △ 2 Must be configured for heat pump to enable YO/D output to be active dehumidification output
- △ 3 Factory Jumper Installed.
- △ 4 Factory installed jumper (on applicable models). Remove jumper and connect to N.C fire alarm circuit if emergency shutdown required.

MIS-2999 A

FIGURE 9
Low Voltage Wiring Diagram:
2 Stage Heat Pump With CHCRV-5 or CRVMWH-3 Vent Option Package With Programmable Thermostat
With Optional On/Off CO₂ Controller

For CHCRV-5A information, refer to Figure 11 on page 15.

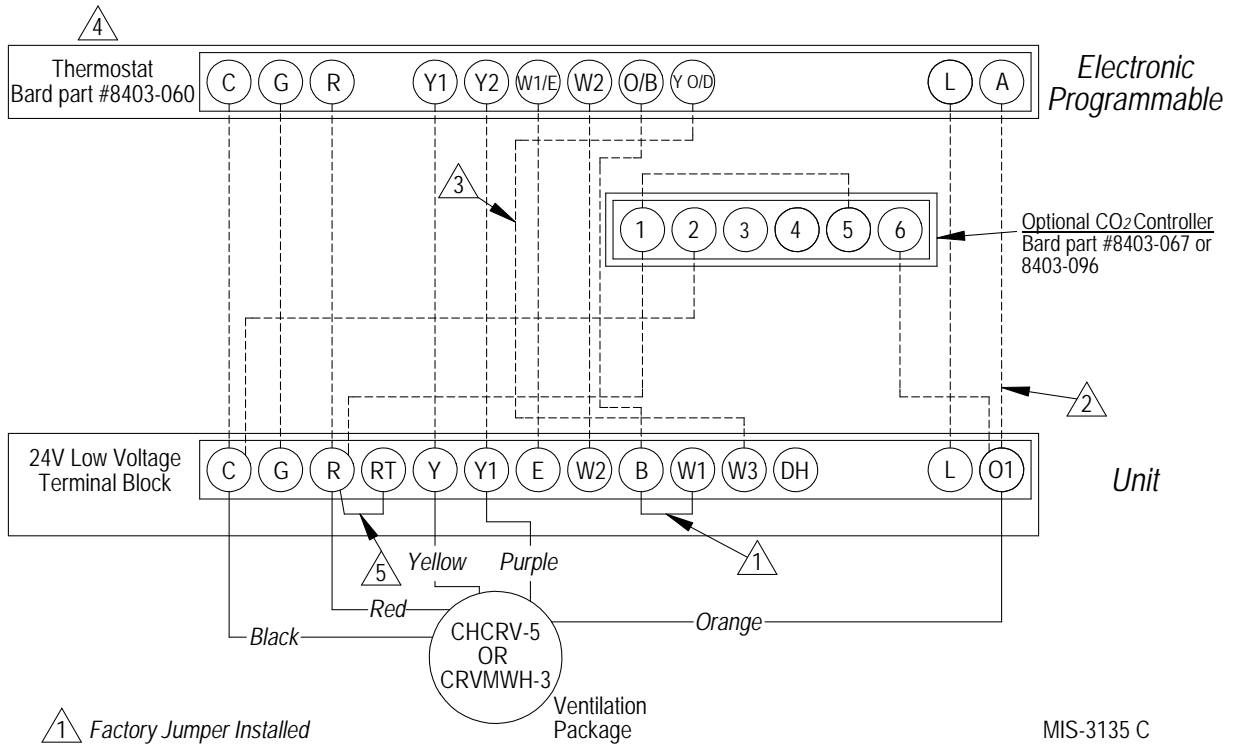

- △1 Factory Jumper Installed
- △2 Do not connect "A" from tstat #8403-060 if optional CO₂ controller is used.
- △3 Wire only needed for dehumidification units
- △4 Must be configured to programmable and fan set to programmed for the "A" output to function during scheduled occupied periods
- △5 Factory installed jumper (on applicable models). Remove jumper and connect to N.C fire alarm circuit if emergency shutdown required.

MIS-3135 C

FIGURE 10

**Low Voltage Wiring Diagram:
2 Stage Heat Pump With CHCRV-5 or CRVMWH-3 Vent Option Package With Programmable Thermostat
With Optional Modulating CO₂ Controller**

For CHCRV-5A information, refer to Figure 13 on page 17.

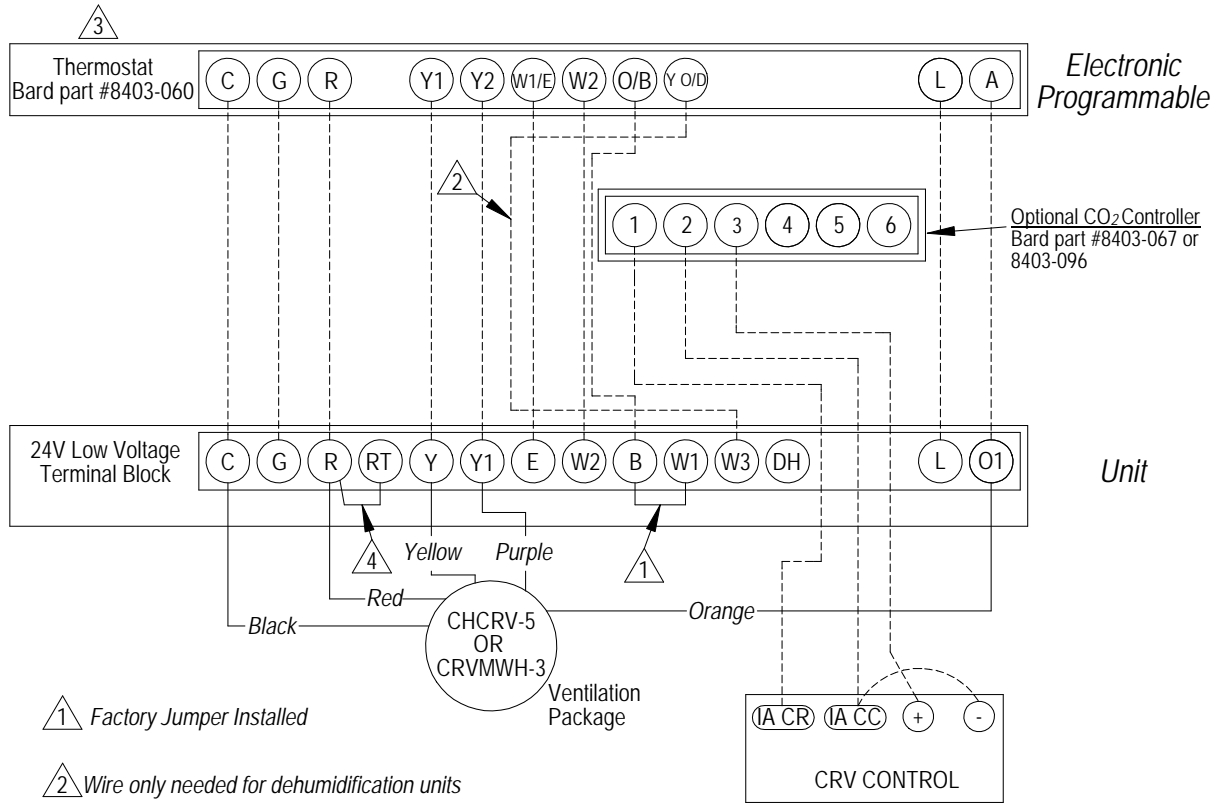

- 1** Factory Jumper Installed
- 2** Wire only needed for dehumidification units
- 3** Must be configured to programmable and fan set to programmed for the "A" output to function during scheduled occupied periods
- 4** Factory installed jumper (on applicable models). Remove jumper and connect to N.C fire alarm circuit if emergency shutdown required.

MIS-3334 B

FIGURE 11
Low Voltage Wiring Diagram:
Heat Pump with Optional CRVS-*A or CHCRV-5A Ventilation Package
with Programmable Thermostat (Recommended), with or without Optional CO₂ Controller

For CRVS- (non A version) information, refer to Figure 2 on page 6.
 For CHCRV-5 (non A version) information, refer to Figure 10 on page 14.*

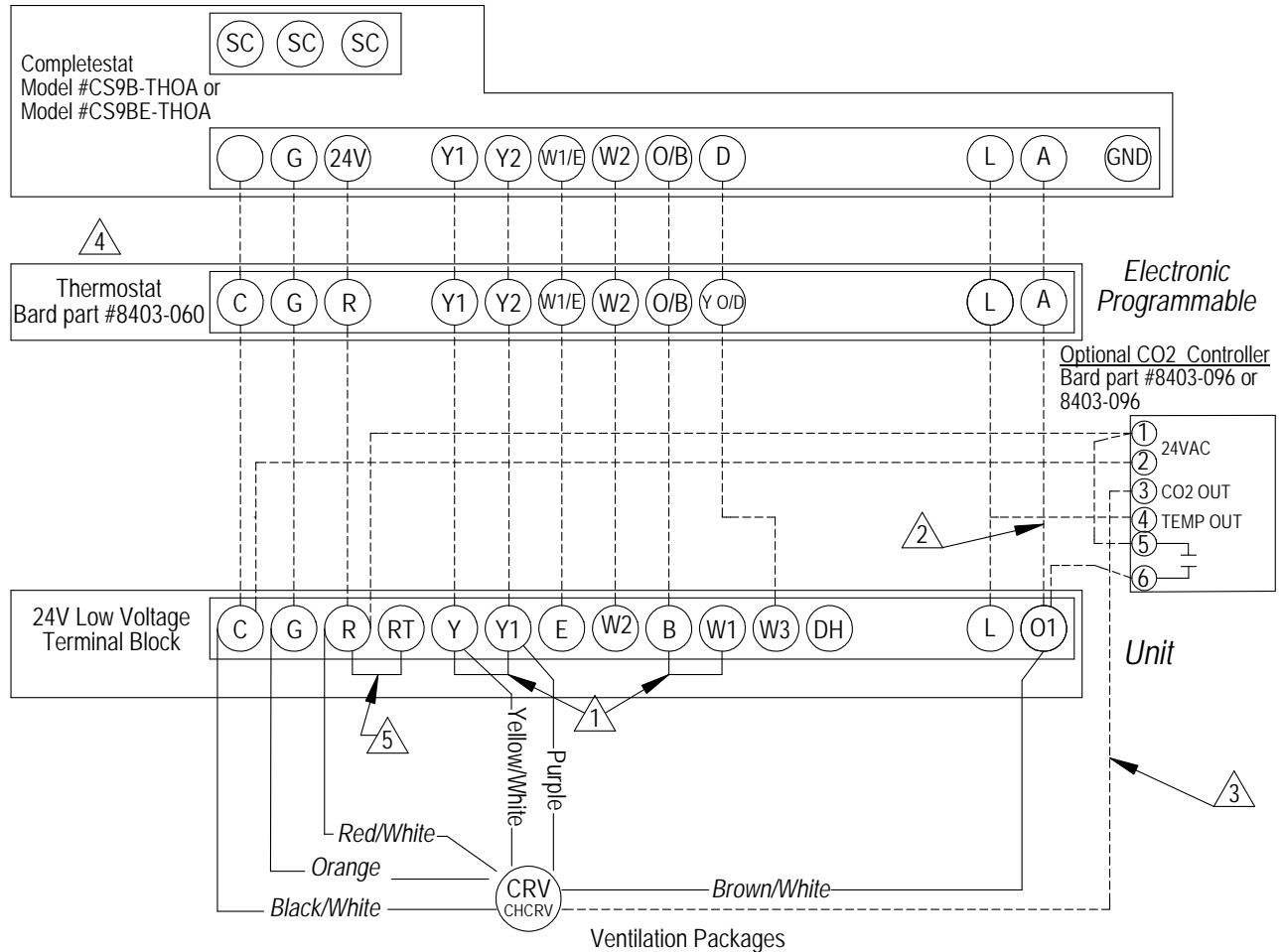

- ① Factory Jumper Installed
- ② Do not connect "A" from tstat #8403-060 if optional CO₂ controller is used.
- ③ Connect orange wire to "G" only if optional CO₂ controller is used.
- ④ Must be configured to programmable and fan set to programmed for the "A" output to function during scheduled occupied periods
- ⑤ Factory installed jumper (on applicable models). Remove jumper and connect to N.C fire alarm circuit if emergency shutdown required.

MIS-4352 B

FIGURE 12
Low Voltage Wiring Diagram:
Heat Pump with Optional CRVS-*A or CHCRV-5A Ventilation Package
with Thermostat (No Occupied Signal), with or without Optional CO₂ Controller

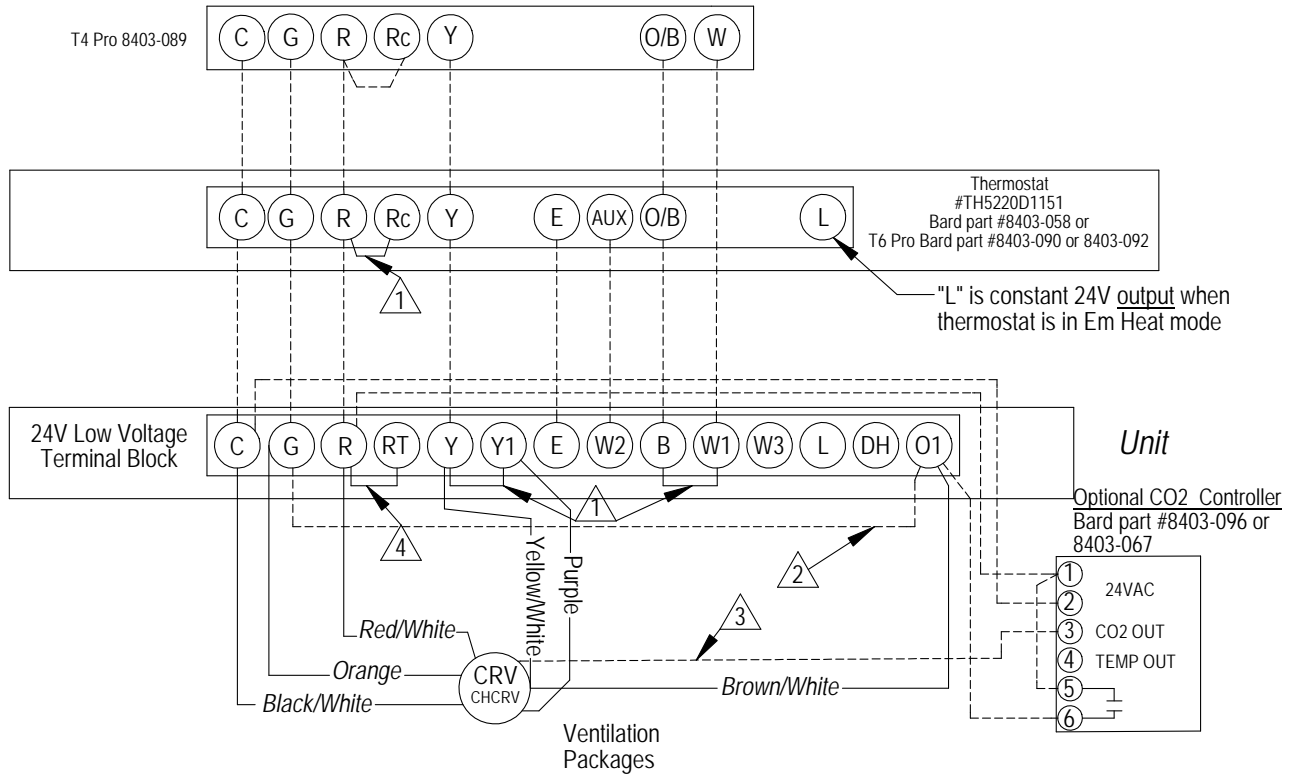

- ① Factory Jumper Installed
- ② Add jumper, ventilation will be active whenever blower operates. Will require a wire change on vent relay to prevent relay lock-out. Refer to ventilator wiring diagram.
- ③ Connect field wire for modulating CO₂ ventilator control. Do NOT connect on/off ventilator control (To minimum blade position)
- ④ Factory installed jumper (on applicable models). Remove jumper and connect to N.C fire alarm circuit if emergency shutdown required.

MIS-4353 A

FIGURE 13
Low Voltage Wiring Diagram:
Heat Pump with Dehumidification Sequence and Optional CRVS-*A Ventilation Package
Using Electronic Thermostat with Combination Temperature and Humidity Control with Optional CO₂ Controller
For CRVS- (non A version) information, refer to Figure 5 on page 9.*

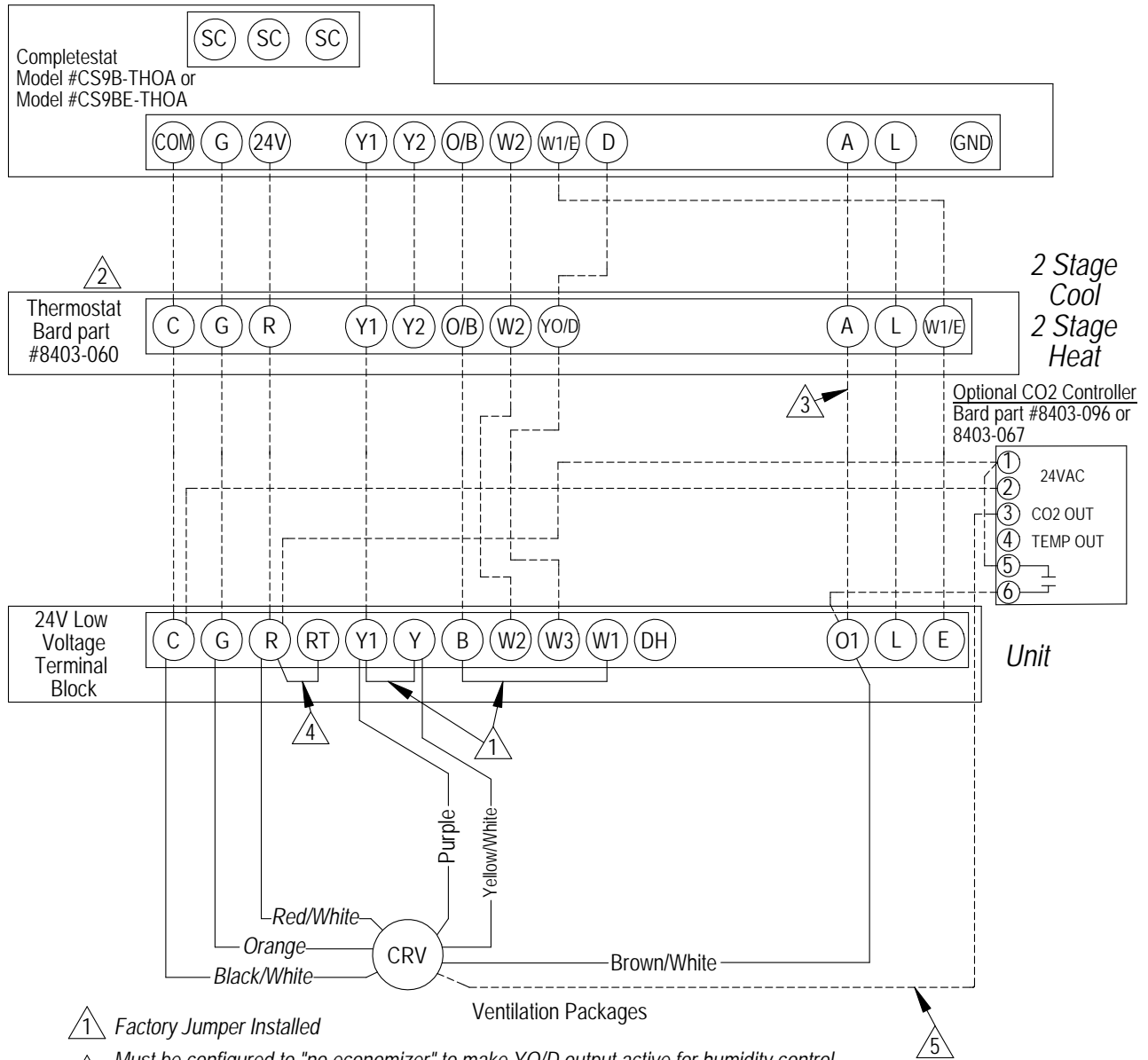

- 1 Factory Jumper Installed
- 2 Must be configured to "no economizer" to make YO/D output active for humidity control. Must be configured to programmable and fan set to programmed fan for the "A" output to function during scheduled occupied periods.
- 3 Do not connect "A" from thermostat if optional CO₂ controller is used.
- 4 Factory installed jumper (on applicable models). Remove jumper and connect to N.C fire alarm circuit if emergency shutdown required.
- 5 Connect field wire for modulating CO₂ ventilator control. Do NOT connect for on/off ventilator control (To minimum blade position).

MIS-4354 A

FIGURE 14
Low Voltage Wiring Diagram:
Heat Pump with Dehumidification Sequence and Optional CRVS-*A Ventilation Package
Using Thermostat (No Occupied Signal), with or without Optional CO₂ Controller

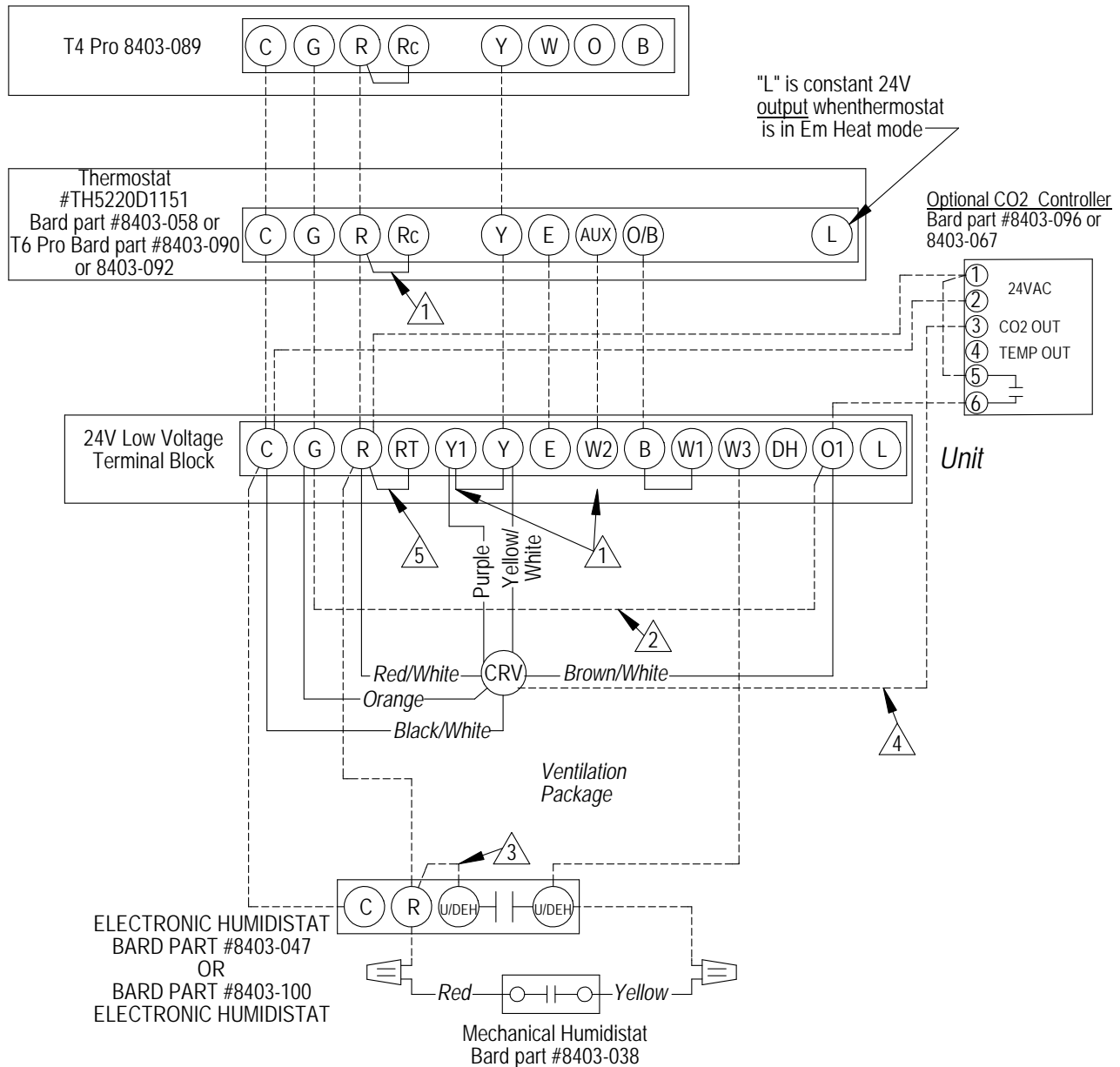

- ① FACTORY JUMPER INSTALLED.
- ② ADD JUMPER, VENTILATION WILL BE ACTIVE WHENEVER BLOWER OPERATES. WILL REQUIRE A WIRE CHANGE ON VENT RELAY TO PREVENT RELAY LOCK-OUT. REFER TO VENTILATOR WIRING DIAGRAM.
- ③ JUMPER NEEDS TO BE ADDED.
- ④ CONNECT FIELD WIRE FOR MODULATING CO₂ VENTILATOR CONTROL. DO NOT CONNECT FOR ON/OFF VENTILATOR CONTROL (TO MINIMUM BLADE POSITION).
- ⑤ FACTORY INSTALLED JUMPER (ON APPLICABLE MODELS). REMOVE JUMPER AND CONNECT TO N.C FIRE ALARM CIRCUIT IF EMERGENCY SHUTDOWN REQUIRED.
- ⑥ HUMIDISTAT 8403-100 WILL NEED TO BE CONFIGURED FOR DEHUMIDIFICATION IN THE MENU. SEE USER'S MANUAL

MIS-4355 B