INSTALLATION INSTRUCTIONS

WALL MOUNTED PACKAGE AIR CONDITIONERS

MODELS

W18A1	W18L1
W24A1	W24L1
W30A1	W30L1
W36A1	W36L1
W42A1	W42L1
W48A1	W48L1
W60A1	W60L1



Bard Manufacturing Company, Inc.
Bryan, Ohio 43506
Since 1914...Moving ahead just as planned.

Manual : 2100-508
Supersedes: **NEW**
File: Volume III Tab 16
Date: 07-07-08

Contents

Getting Other Information and Publications 3

Wall Mount General Information

Wall Mount Model Nomenclature	4
Shipping Damage	4
General	4
Duct Work	5
Filters	5
Fresh Air Intake	5
Condensate Drain	5

Installation Instructions

Wall Mounting Information	6
Mounting the Unit	6
Clearances Required	6
Minimum Clearances	6
Wiring – Main Power	14
Wiring – Low Voltage Wiring	14

Figures

Figure 1 Fresh Air Damper Assembly	5
Figure 2 Unit Dimensions	7
Figure 3A Mounting Instructions	8
Figure 3B Mounting Instructions - W18, W24, W30, W36	9
Figure 3C Mounting Instructions - W42, W48, W60	10
Figure 4 Electric Heat Clearance	11
Figure 5 Wall Mounting Instructions	12
Figure 6 Wall Mounting Instructions	12
Figure 7 Common Wall Mounting Installations	13
Figure 8 Fan Blade Setting	18

Start Up

General	15
Topping Off System Charge	15
Safety Practices	15
Important Installer Note	16
Wall Mounted Air Conditioner	16
Three Phase Scroll Compressor	16
Phase Monitor	16
Condenser Fan Operation	16
Service Hints	16
Sequence of Operation	17
Compressor Control Module	17
Adjustments	17
Pressure Service Ports	17

Troubleshooting

Fan Blade Setting Dimensions	18
Removal of Fan Shroud	18
Refrigerant Charge	18

Tables

Table 1 Fan Blade Dimensions	18
Table 2 Refrigerant Charge	18
Table 3 Cooling Pressure	19
Table 4 Electrical Specifications W**A	20
Table 5 Electrical Specifications W**L	21
Table 6 Recommended Airflow	22
Table 7 Indoor Blower Performance	22
Table 8 Maximum ESP Electric Heat Only	22
Table 9 Electric Heat	23
Table 10 Optional Accessories	24
Table 11 Vent & Control Options	25

GETTING OTHER INFORMATION AND PUBLICATIONS

These publications can help you install the air conditioner or heat pump. You can usually find these at your local library or purchase them directly from the publisher. Be sure to consult current edition of each standard.

National Electrical Code ANSI/NFPA 70

Standard for the Installation ANSI/NFPA 90A
of Air Conditioning and Ventilating Systems

Standard for Warm Air ANSI/NFPA 90B
Heating and Air Conditioning Systems

Load Calculation for ACCA Manual J
Residential Winter and Summer Air Conditioning

Duct Design for Residential ACCA Manual D
Winter and Summer Air Conditioning and Equipment
Selection

FOR MORE INFORMATION, CONTACT THESE PUBLISHERS:

ACCA **Air Conditioning Contractors of America**
1712 New Hampshire Ave. N.W.
Washington, DC 20009
Telephone: (202) 483-9370
Fax: (202) 234-4721

ANSI **American National Standards Institute**
11 West Street, 13th Floor
New York, NY 10036
Telephone: (212) 642-4900
Fax: (212) 302-1286

ASHRAE **American Society of Heating, Refrigeration
and Air Conditioning Engineers, Inc.**
1791 Tullie Circle, N.E.
Atlanta, GA 30329-2305
Telephone: (404) 636-8400
Fax: (404) 321-5478

NFPA **National Fire Protection Association**
Batterymarch Park
P.O. Box 9101
Quincy, MA 02269-9901
Telephone: (800) 344-3555
Fax: (617) 984-7057

Manufactured under the following
U.S. Patent numbers:

5,485,878; 5,301,777; 5,002,116; 4,924,934;
4,875,520; 4,825,936

WALL MOUNT GENERAL INFORMATION

AIR CONDITIONER WALL MOUNT MODEL NOMENCLATURE

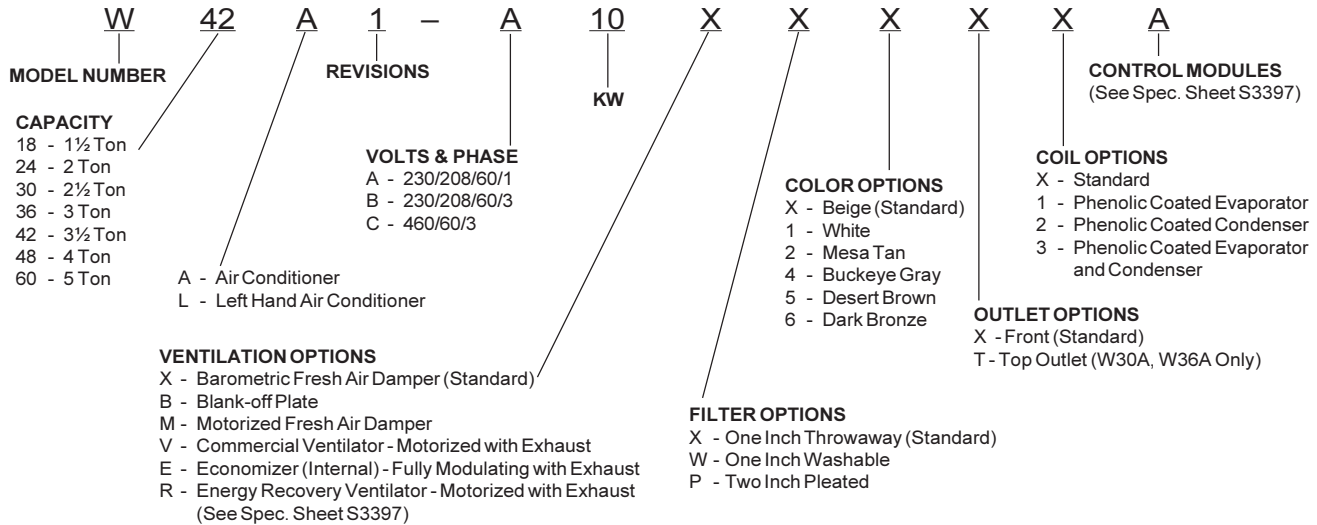

NOTE: Vent options X, B and M are without exhaust capability. May require separate field supplied barometric relief in building.

SHIPPING DAMAGE

Upon receipt of equipment, the carton should be checked for external signs of shipping damage. If damage is found, the receiving party must contact the last carrier immediately, preferably in writing, requesting inspection by the carrier's agent.

GENERAL

The equipment covered in this manual is to be installed by trained, experienced service and installation technicians.

The refrigerant system is completely assembled and charged. All internal wiring is complete.

The unit is designed for use with or without duct work. Flanges are provided for attaching the supply and return ducts.

These instructions explain the recommended method to install the air cooled self-contained unit and the electrical wiring connections to the unit.

These instructions and any instructions packaged with any separate equipment required to make up the entire air conditioning system should be carefully read before beginning the installation. Note particularly "Starting Procedure" and any tags and/or labels attached to the equipment.

While these instructions are intended as a general recommended guide, they do not supersede any national and/or local codes in any way. Authorities having jurisdiction should be consulted before the installation is made. See Page 3 for information on codes and standards.

Size of unit for a proposed installation should be based on heat loss calculation made according to methods of Air Conditioning Contractors of America (ACCA). The air duct should be installed in accordance with the Standards of the National Fire Protection Association for the Installation of Air Conditioning and Ventilating Systems of Other Than Residence Type, NFPA No. 90A, and Residence Type Warm Air Heating and Air Conditioning Systems, NFPA No. 90B. Where local regulations are at a variance with instructions, installer should adhere to local codes.

DUCT WORK

All duct work, supply and return, must be properly sized for the design airflow requirement of the equipment. Air Conditioning Contractors of America (ACCA) is an excellent guide to proper sizing. All duct work or portions thereof not in the conditioned space should be properly insulated in order to both conserve energy and prevent condensation or moisture damage.

Refer to Maximum ESP of operation Electric Heat Table 6.

Design the duct work according to methods given by the Air Conditioning Contractors of America (ACCA). When duct runs through unheated spaces, it should be insulated with a minimum of one inch of insulation. Use insulation with a vapor barrier on the outside of the insulation. Flexible joints should be used to connect the duct work to the equipment in order to keep the noise transmission to a minimum.

Models W18 & W24 as approved for zero inch clearance to the supply duct. For model series W30, W36, W42, W48 and W60 a 1/4 inch clearance to combustible material for the first three feet of duct attached to the outlet air frame is required. See Wall Mounting Instructions and Figures 3 and 4 for further details.

Ducts through the walls must be insulated and all joints taped or sealed to prevent air or moisture entering the wall cavity.

Some installations may not require any return air duct. A metallic return air grille is required with installations not requiring a return air duct. The spacing between louvers on the grille shall not be larger than 5/8 inch.

Any grille that meets with 5/8 inch louver criteria may be used. It is recommended that Bard Return Air Grille Kit RG2 through RG5 or RFG2 through RFG5 be installed when no return duct is used. Contact distributor or factory for ordering information. If using a return air filter grille, filters must be of sufficient size to allow a maximum velocity of 400 fpm.

NOTE: If no return air duct is used, applicable installation codes may limit this cabinet to installation only in a single story structure.

FILTERS

A 1-inch throwaway filter is standard with each unit. The filter slides into position making it easy to service. This filter can be serviced from the outside by removing the filter access panel. A 1-inch washable filter and 2-inch pleated filter are also available as optional accessories. The internal filter brackets are adjustable to accommodate the 2-inch filter by bending two (2) tabs down on each side of the filter support bracket.

FRESH AIR INTAKE

All units are built with fresh air inlet slots punched in the service door.

If the unit is equipped with a fresh air damper assembly, the assembly is shipped already attached to the unit. The damper blade is locked in the closed position. To allow the damper to operate, the maximum and minimum blade position stops must be installed. See Figure 1.

All capacity, efficiency and cost of operation information is based upon the fresh air blank-off plate in place and is recommended for maximum energy efficiency.

The blank-off plate is available upon request from the factory and is installed in place of the fresh air damper shipped with each unit.

CONDENSATE DRAIN

A plastic drain hose extends from the drain pan at the top of the unit down to the unit base. There are openings in the unit base for the drain hose to pass through. In the event the drain hose is connected to a drain system of some type, it must be an open or vented type system to assure proper drainage.

**FIGURE 1
FRESH AIR DAMPER**

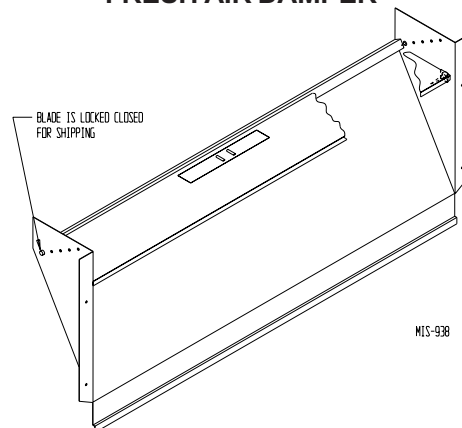

INSTALLATION INSTRUCTIONS

WALL MOUNTING INFORMATION

1. Two holes for the supply and return air openings must be cut through the wall as shown in Figure 3.
2. On wood frame walls, the wall construction must be strong and rigid enough to carry the weight of the unit without transmitting any unit vibration.
3. Concrete block walls must be thoroughly inspected to insure that they are capable of carrying the weight of the installed unit.



WARNING

Failure to provide the 1/4 inch clearance between the supply duct and a combustible surface for the first 3 feet of duct can result in fire causing damage, injury or death.

MOUNTING THE UNIT

1. These units are secured by wall mounting brackets which secure the unit to the outside wall surface at both sides. A bottom mounting bracket, attached to skid for shipping, is provided for ease of installation, but is not required.
2. The unit itself is suitable for 0 inch clearance, but the supply air duct flange and the first 3 feet of supply air duct require a minimum of 1/4 inch clearance to combustible material for model series W30, W36, W42, W48 and W60. However, it is generally recommended that a 1-inch clearance is used for ease of installation and maintaining the required clearance to combustible material. See Figure 3 for details on opening sizes.
3. Locate and mark lag bolt locations and bottom mounting bracket location. See Figure 3.
4. Mount bottom mounting bracket.
5. Hook top rain flashing, attached to front - right of supply flange for shipping, under back bend of top.
6. Position unit in opening and secure with 5/16 lag bolts; use 7/8 inch diameter flat washers on the lag bolts.
7. Secure rain flashing to wall and caulk across entire length of top. See Figure 3.
8. For additional mounting rigidity, the return air and supply air frames or collars can be drilled and screwed or welded to the structural wall itself (depending upon wall construction). Be sure to observe required clearance if combustible wall.
9. On side-by-side installations, maintain a minimum of 20 inches clearance on right side to allow access to control panel and heat strips, and to allow proper airflow to the outdoor coil. Additional clearance may be required to meet local or national codes.

Clearances Required for Service Access and Adequate Condenser Airflow

MODELS	LEFT SIDE	RIGHT SIDE
W18A, W24A, W30A, W36A	15"	20"
W18L, W24L, W30L, W36L	20"	15"
W42A, W48A, W60A	20"	20"
W42L, W48L, W60L	20"	20"

NOTE: For side by side installation of two (2) W**A models there must be 20" between units. This can be reduced to 15" by using a W**L model (left side compressor and controls) for the left unit and WA (right side compressor and controls) for right unit.

See W**A Specification S3397 & W**L Specification S3279.

Minimum Clearances Required to Combustible Materials

MODELS	SUPPLY AIR DUCT FIRST THREE FEET	CABINET
W18A,L / W24A, L	0"	0"
W30A,L / W36A, L	1/4"	0"
W42A,L / W48A,L / W60A,L	1/4"	0"

FIGURE 2

Dimensions of Basic Unit for Architectural and Installation Requirements (Nominal)

MODEL	WIDTH (W)	DEPTH (D)	HEIGHT (H)	SUPPLY			RETURN															
				A	B	C	B	E	F	G	I	J	K	L	M	N	O	P	Q	R	S	T
W18A, L W24A, L	33.300	17.125	70.563	7.88	19.88	11.88	19.88	35.00	11.00	25.75	20.56	26.75	28.06	29.25	27.00	2.63	34.13	22.06	10.55	4.19	12.00	5.00
W30A, L W36A, L	38.200	17.125	70.563	7.88	27.88	13.88	27.88	40.00	11.00	25.75	17.93	26.75	28.75	29.25	27.00	2.75	39.19	22.75	9.14	4.19	12.00	5.00
W42A, L W48A, L W60A, L	42.075	22.432	84.875	9.88	29.88	15.88	29.88	43.88	13.63	31.66	30.00	32.68	26.94	34.69	32.43	3.37	42.88	23.88	10.00	2.00	16.00	1.88

All dimensions are in inches. Dimensional drawings are not to scale.

WA
RIGHT
UNIT**

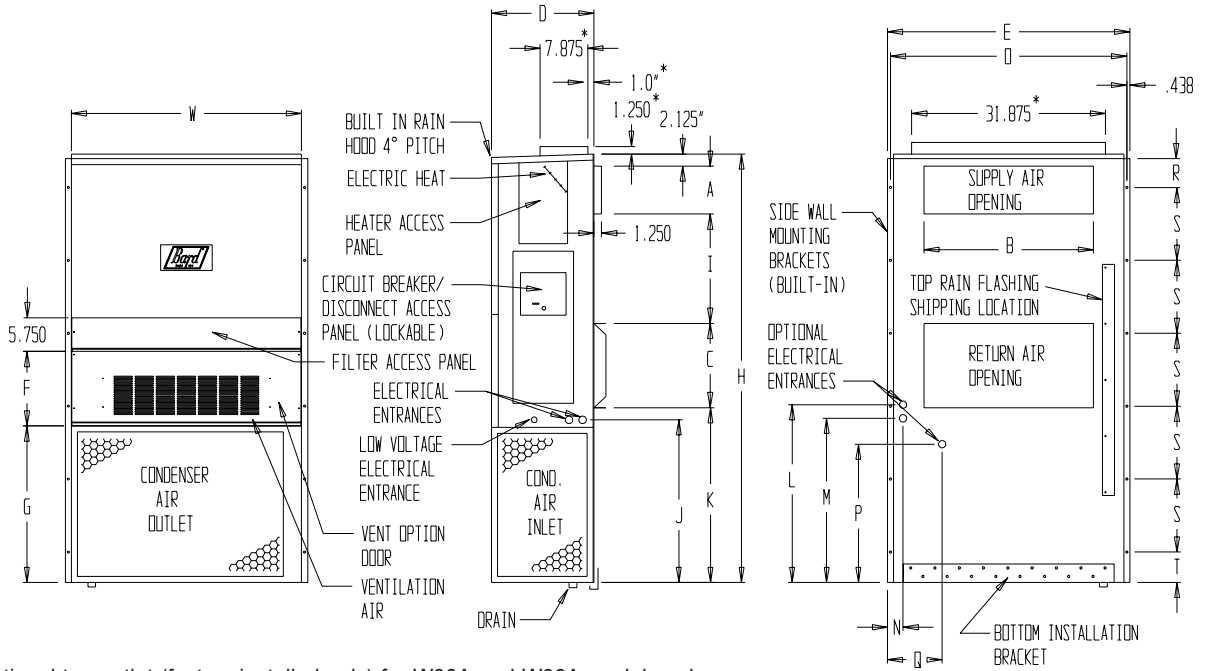

*Optional top outlet (factory installed only) for W30A and W36A models only.

MIS-2487

WL
LEFT
UNIT**

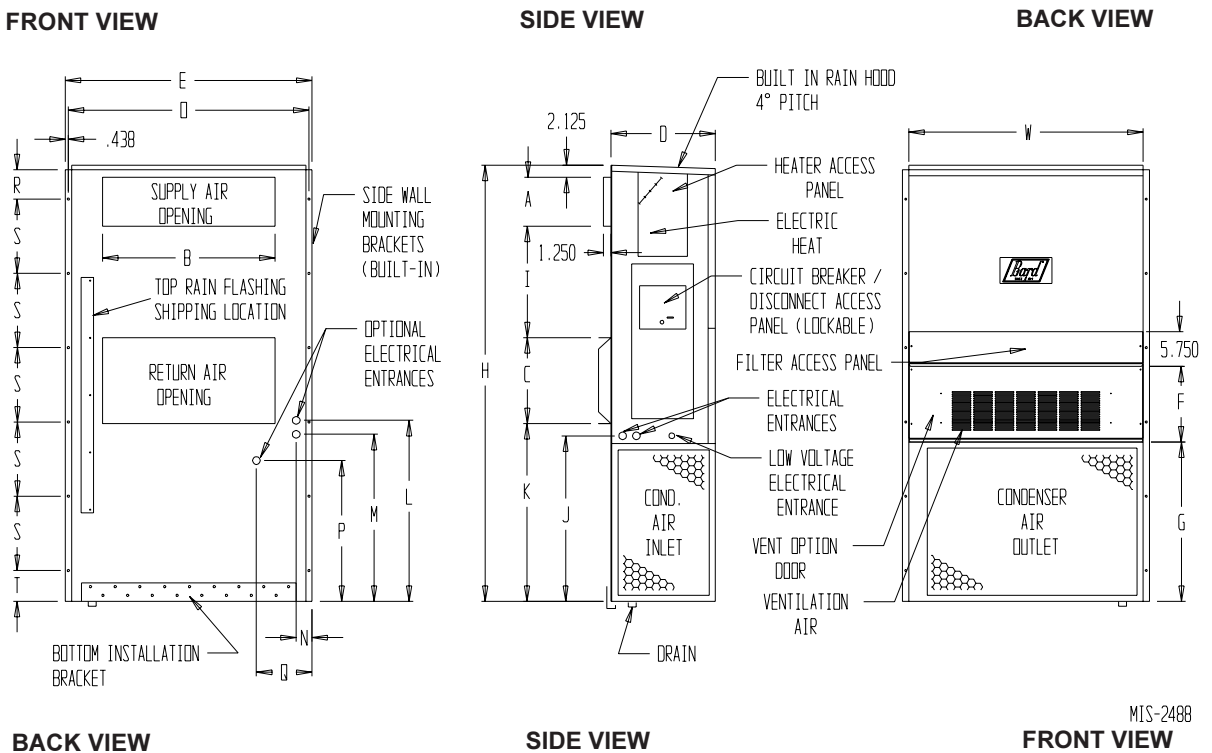

MIS-2488

FIGURE 3A
W18A1, W18L1, W24A1, W24L1
MOUNTING INSTRUCTIONS

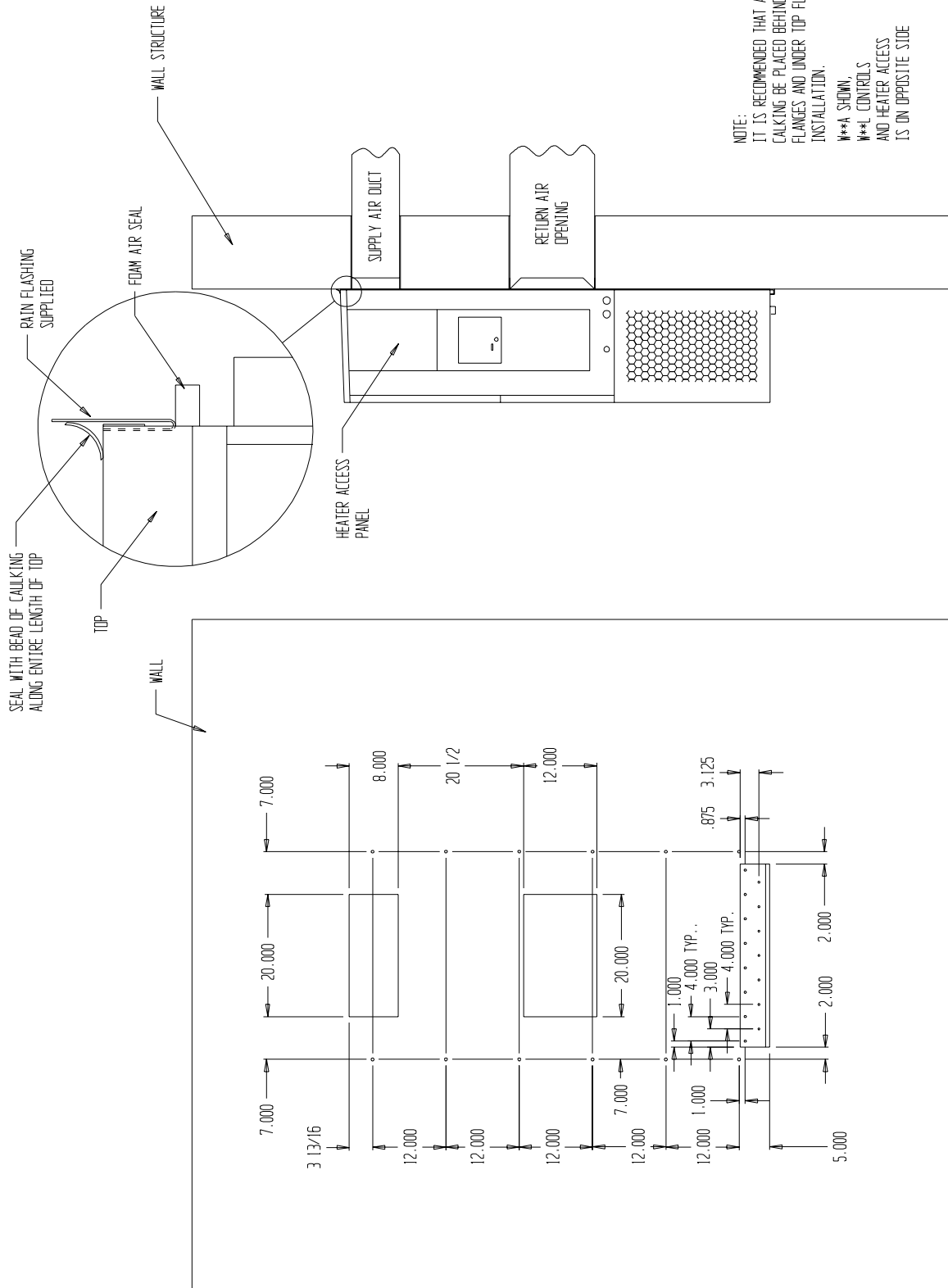

NOTE:
 IT IS RECOMMENDED THAT A BEAD OF SILICONE
 CAULKING BE PLACED BEHIND THE SIDE MOUNTING
 FLANGES AND UNDER TOP FLASHING AT TIME OF
 INSTALLATION.
 ***A SHOWN,
 ***L CONTROLS
 AND HEATER ACCESS
 IS ON OPPOSITE SIDE

MIS-353 A

FIGURE 3B
W30A1, W30L1, W36A1, W36L1
MOUNTING INSTRUCTIONS

	A	B	C	D	E
REQUIRED DIMENSIONS TO MAINTAIN 1/4" MIN. CLEARANCE FROM COMBUSTIBLE MATERIALS	28 1/2	8 1/2	5 1/4	3 13/16	17 5/8
REQUIRED DIMENSIONS TO MAINTAIN RECOMMENDED 1" CLEARANCE FROM COMBUSTIBLE MATERIALS	30	10	4 1/2	4 9/16	16 7/8

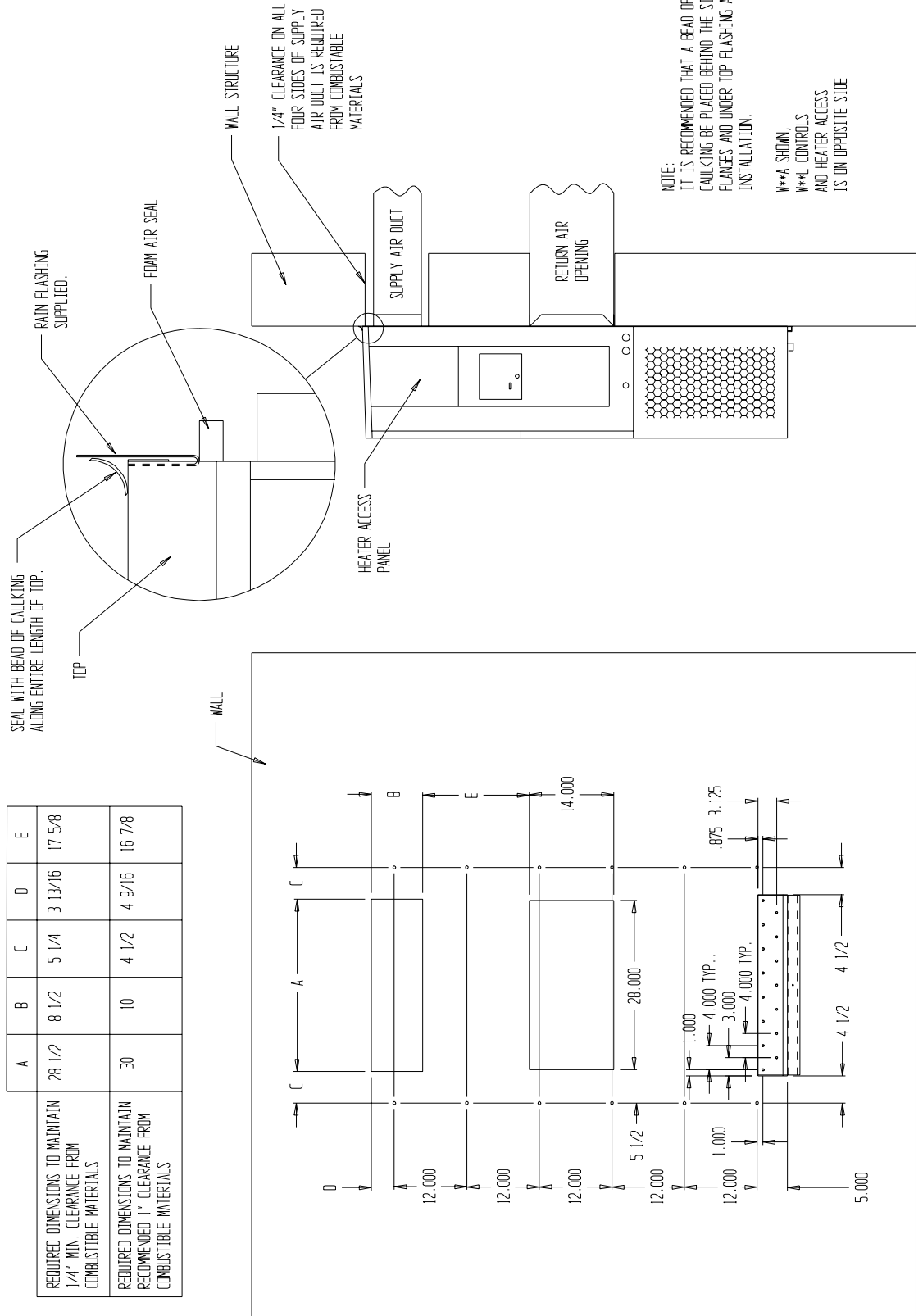
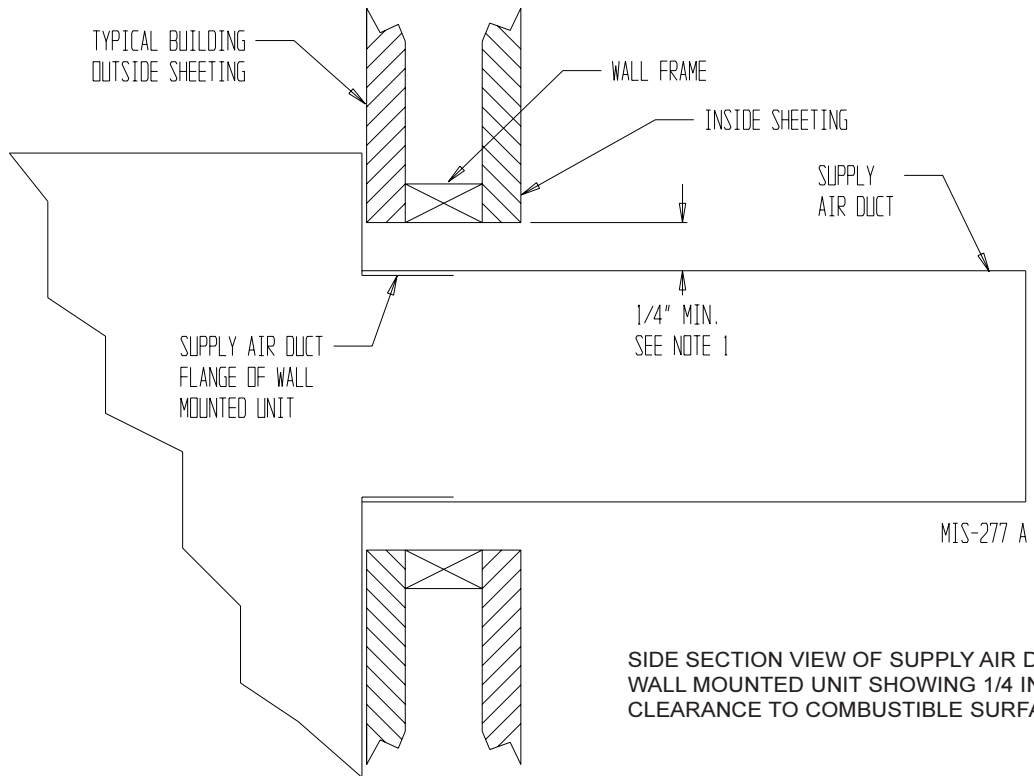

FIGURE 4
ELECTRIC HEAT CLEARANCE
W30A1, W30L1, W36A1, W36L1, W42A1, W42L1, W48A1, W48L1, W60A1, W60L1



WARNING

A *minimum* of 1/4 inch clearance must be maintained between the supply air duct and combustible materials. This is required for the first 3 feet of ducting.

It is important to insure that the 1/4 inch minimum spacing is maintained at all points.

Failure to do this could result in overheating the combustible material and may result in a fire causing damage, injury or death.

FIGURE 5 WALL MOUNTING INSTRUCTIONS

SEE FIGURE 3 – MOUNTING INSTRUCTIONS

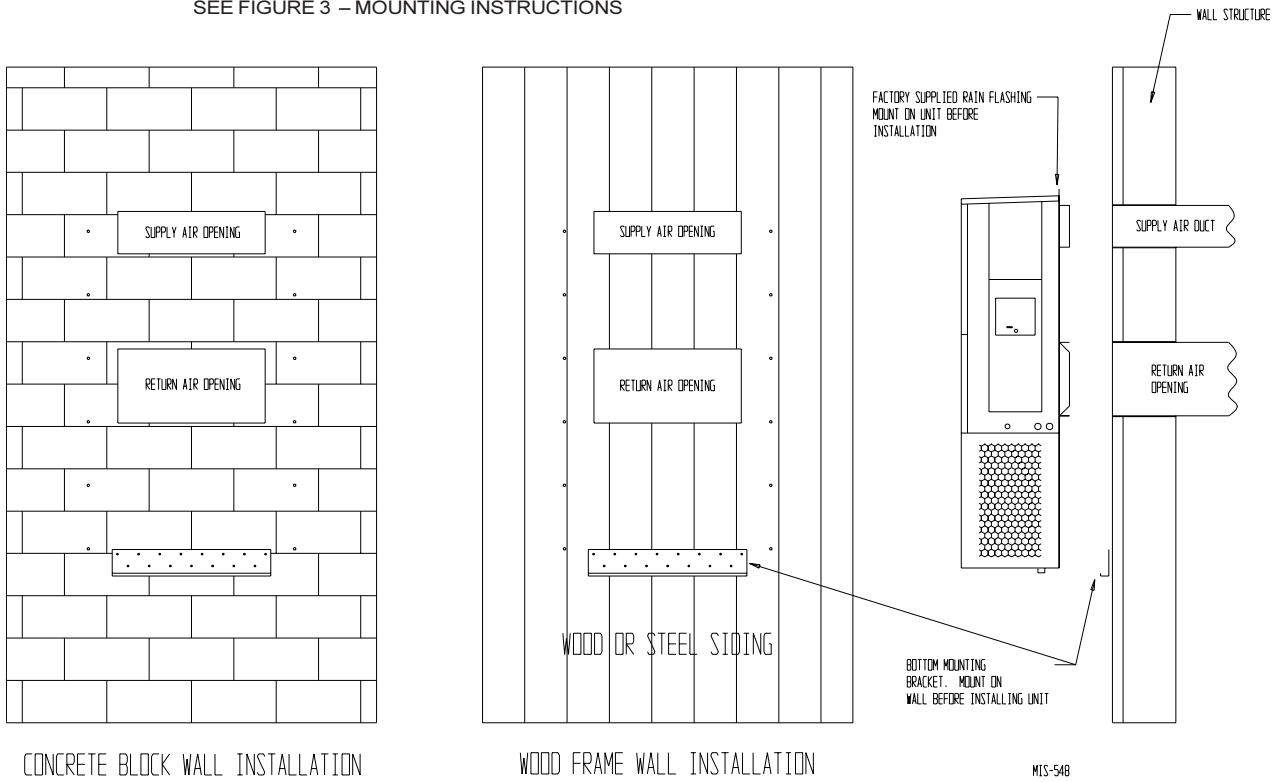
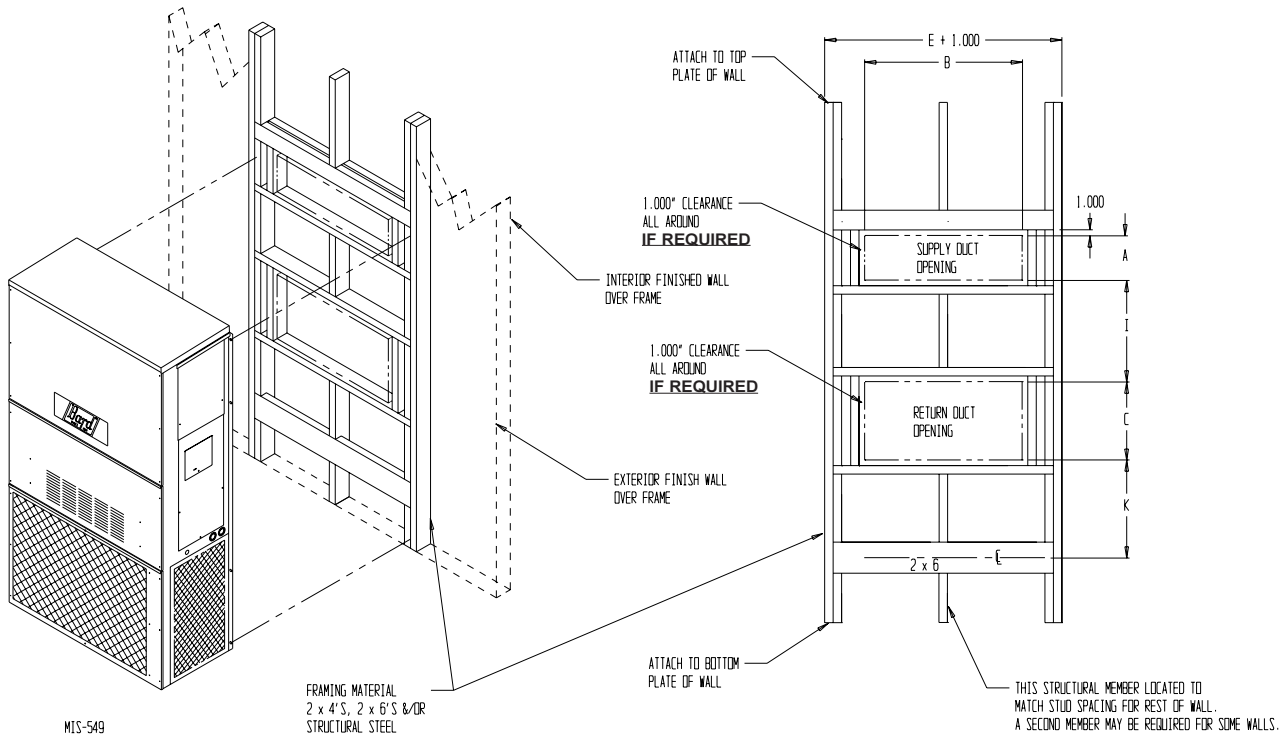
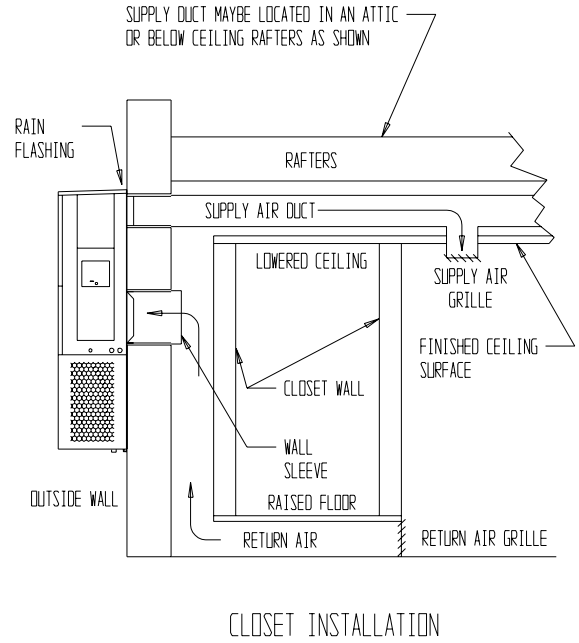
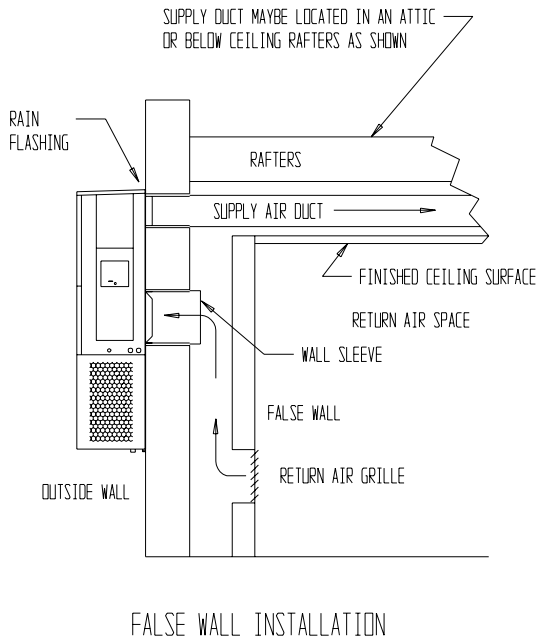
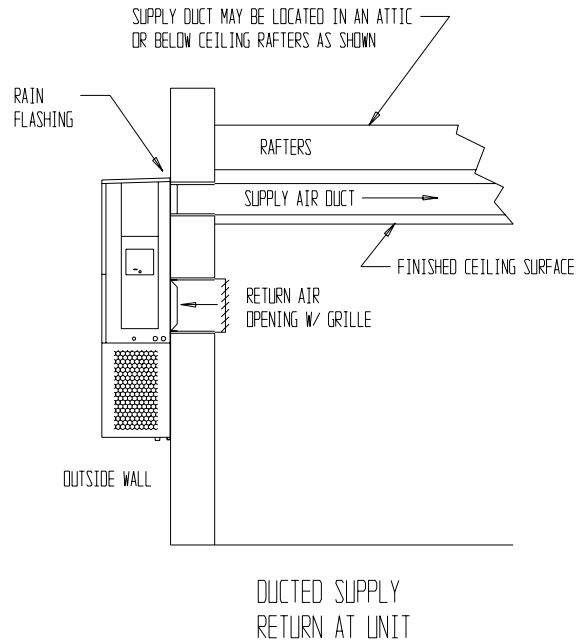
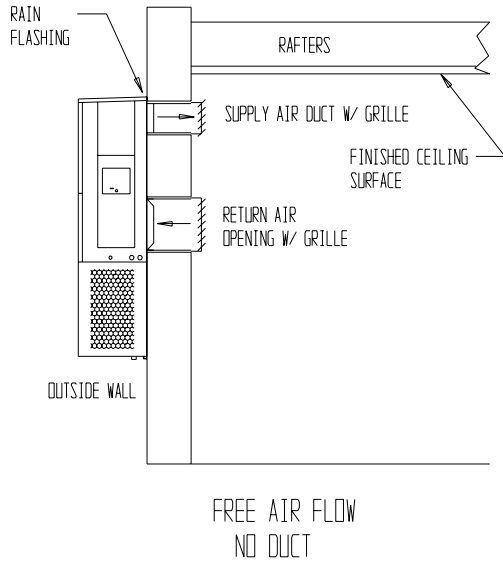

FIGURE 6 WALL MOUNTING INSTRUCTIONS

SEE UNIT DIMENSIONS, FIGURE 2,
FOR ACTUAL DIMENSIONS



**FIGURE 7
COMMON WALL MOUNTING INSTALLATIONS**



MIS-550 A

WIRING – MAIN POWER

Refer to the unit rating plate for wire sizing information and maximum fuse or “HACR” type circuit breaker size. Each outdoor unit is marked with a “Minimum Circuit Ampacity”. This means that the field wiring used must be sized to carry that amount of current.

Depending on the installed KW of electric heat, there may be two field power circuits required. If this is the case, the unit serial plate will so indicate. All models are suitable only for connection with copper wire. Each unit and/or wiring diagram will be marked “Use Copper Conductors Only”. These instructions **must be** adhered to. Refer to the National Electrical Code (NEC) for complete current carrying capacity data on the various insulation grades of wiring material. All wiring must conform to NEC and all local codes.

The electrical data lists fuse and wire sizes (75° C copper) for all models including the most commonly used heater sizes. Also shown are the number of field power circuits required for the various models with heaters.

The unit rating plate lists a “Maximum Time Delay Relay Fuse” or “HACR” type circuit breaker that is to be used with the equipment. The correct size must be used for proper circuit protection and also to assure that there will be no nuisance tripping due to the momentary high starting current of the compressor motor.

The disconnect access door on this unit may be locked to prevent unauthorized access to the disconnect. To convert for the locking capability, bend the tab located in the bottom left-hand corner of the disconnect opening under the disconnect access panel straight out. This tab will now line up with the slot in the door. When shut, a padlock may be placed through the hole in the tab preventing entry.

See “Start Up” section for important information on three phase scroll compressor start ups.

See Tables 4 & 5 for Electrical Specifications.

WIRING – LOW VOLTAGE WIRING

230/208V, 1 phase and 3 phase equipment dual primary voltage transformers. All equipment leaves the factory wired on 240V tap. For 208V operation, reconnect from 240V to 208V tap. The acceptable operating voltage range for the 240 and 208V taps are:

TAP	RANGE
240	253 – 216
208	220 – 187

NOTE: The voltage should be measured at the field power connection point in the unit and while the unit is operating at full load (maximum amperage operating condition).

For wiring size and connections, refer to Wiring Manual 2100-507.

START UP

THESE UNITS REQUIRE R-410A REFRIGERANT AND POLYOL ESTER OIL.

GENERAL:

1. Use separate service equipment to avoid cross contamination of oil and refrigerants.
2. Use recovery equipment rated for R-410A refrigerant.
3. Use manifold gauges rated for R-410A (800 psi/250 psi low).
4. R-410A is a binary blend of HFC-32 and HFC-125.
5. R-410A is nearly azeotropic - similar to R-22 and R-12. Although nearly azeotropic, charge with liquid refrigerant.
6. R-410A operates at 40-70% higher pressure than R-22, and systems designed for R-22 cannot withstand this higher pressure.
7. R-410A has an ozone depletion potential of zero, but must be reclaimed due to its global warming potential.
8. R-410A compressors use polyolester oil.
9. Polyol Ester oil is hygroscopic; it will rapidly absorb moisture and strongly hold this moisture in the oil.
10. A liquid line dryer must be used - even a deep vacuum will not separate moisture from the oil.
11. Limit atmospheric exposure to 15 minutes.
12. If compressor removal is necessary, always plug compressor immediately after removal. Purge with small amount of nitrogen when inserting plugs.

TOPPING OFF SYSTEM CHARGE

If a leak has occurred in the system, Bard Manufacturing recommends reclaiming, evacuating (see criteria above), and charging to the nameplate charge. If done correctly, topping off the system charge can be done without problems.

With R-410A, there are no significant changes in the refrigerant composition during multiple leaks and recharges. R-410A refrigerant is close to being an azeotropic blend (it behaves like a pure compound or single component refrigerant). The remaining refrigerant charge, in the system, may be used after leaks have occurred and then “top-off” the charge by utilizing the charging charts on the inner control panel cover as a guideline.

REMEMBER: When adding R-410A refrigerant, it must come out of the charging cylinder/tank as a liquid to avoid any fractionation, and to insure optimal system performance. Refer to instructions for the cylinder that is being utilized for proper method of liquid extraction.



WARNING

Failure to conform to these practices could lead to damage, injury or death.

SAFETY PRACTICES:

1. Never mix R-410A with other refrigerants.
2. Use gloves and safety glasses, Polyol Ester oils can be irritating to the skin, and liquid refrigerant will freeze the skin.
3. Never use air and R-410A to leak check; the mixture may become flammable.
4. Do not inhale R-410A – the vapor attacks the nervous system, creating dizziness, loss of coordination and slurred speech. Cardiac irregularities, unconsciousness and ultimate death can result from breathing this concentration.
5. Do not burn R-410A. This decomposition produces hazardous vapors. Evacuate the area if exposed.
6. Use only cylinders rated DOT4BA/4BW 400.
7. Never fill cylinders over 80% of total capacity.
8. Store cylinders in a cool area, out of direct sunlight.
9. Never heat cylinders above 125°F.
10. Never trap liquid R-410A in manifold sets, gauge lines or cylinders. R-410A expands significantly at warmer temperatures. Once a cylinder or line is full of liquid, any further rise in temperature will cause it to burst.

START UP (Continued)

IMPORTANT INSTALLER NOTE

For improved start up performance wash the indoor coil with a dish washing detergent.

HIGH PRESSURE SWITCH

All W**A/W**L wall mounted air conditioner series models are supplied with a remote reset for the high and low pressure switch. If tripped, this pressure switch may be reset by turning the thermostat off then back on again.

THREE PHASE SCROLL COMPRESSOR START UP INFORMATION

Scroll compressors, like several other types of compressors, will only compress in one rotational direction. Direction of rotation is not an issue with single phase compressors since they will always start and run in the proper direction.

However, three phase compressors will rotate in either direction depending upon phasing of the power. Since there is a 50-50 chance of connecting power in such a way as to cause rotation in the reverse direction, verification of proper rotation must be made. Verification of proper rotation direction is made by observing that suction pressure drops and discharge pressure rises when the compressor is energized. Reverse rotation also results in an elevated sound level over that with correct rotation, as well as substantially reduced current draw compared to tabulated values.

Verification of *proper rotation* must be made at the time the equipment is put into service. If improper rotation is corrected at this time, there will be no negative impact on the durability of the compressor. However, reverse operation for over one hour may have a negative impact on the bearing due to oil pump out.

NOTE: If compressor is allowed to run in reverse rotation for several minutes, the compressor's internal protector will trip.

All three phase ZP compressors are wired identically internally. As a result, once the correct phasing is determined for a specific system or installation, connecting properly phased power leads to the same Fusite terminal should maintain proper rotation direction.

The direction of rotation of the compressor may be changed by reversing any two line connections to the unit.

PHASE MONITOR

All units with three phase scroll compressors are equipped with a 3 phase line monitor to prevent compressor damage due to phase reversal.

The phase monitor in this unit is equipped with two LEDs. If the Y signal is present at the phase monitor and phases are correct the green LED will light.

If phases are reversed, the red fault LED will be lit and compressor operation is inhibited.

If a fault condition occurs, reverse two of the supply leads to the unit. ***Do not reverse any of the unit factory wires as damage may occur.***

CONDENSER FAN OPERATION

Applies to W42, W48 and W60 models only. The condenser fan motor on 230/208 volt, one and three phase, 60 HZ units is a two-speed motor that comes factory wired on high speed for peak performance. If ambient conditions permit, it can be reconnected to low speed (red wire) for lower sound level. See wiring diagram.

50 HZ models must have fan wired on low speed. These models are factory wired on low speed.

SERVICE HINTS

1. Caution owner/operator to maintain clean air filters at all times. Also, not to needlessly close off supply and return air registers. This reduces airflow through the system, which shortens equipment service life as well as increasing operating costs.
2. Check all power fuses or circuit breakers to be sure they are the correct rating.
3. Periodic cleaning of the outdoor coil to permit full and unrestricted airflow circulation is essential.

SEQUENCE OF OPERATION

COOLING – Circuit R-Y makes at thermostat pulling in compressor contactor, starting the compressor and outdoor motor. The G (indoor motor) circuit is automatically completed on any call for cooling operation or can be energized by manual fan switch on subbase for constant air circulation. On a call for heating, circuit R-W1 make at the thermostat pulling in heat contact for the strip heat and blower operation. On a call for second stage heat, R-W2 makes bringing on second heat contactor, if so equipped.

COMPRESSOR CONTROL MODULE

The compressor control module is standard on all models covered by this manual. The compressor control module is an anti-short cycle/lockout timer with high and low pressure switch monitoring and alarm relay output.

Adjustable Delay On Make And Break Timer

On initial power up or anytime power is interrupted to the unit, the *delay on make* period begins, which will be 2 minutes plus 10% of the *delay on break* setting. When the delay on make is complete and the high pressure switch and low pressure switch is closed, the compressor contactor is energized. Upon shutdown, the delay on break timer starts and prevents restart until the delay on break and delay on make periods have expired.

During routine operation of the unit with no power interruptions, the compressor will operate on demand with no delay.

High Pressure Switch and Lockout Sequence

If the high pressure switch opens, the compressor contactor will de-energize immediately. The lockout timer will go into a *soft lockout* and stay in soft lockout until the high pressure switch closes and the delay on break time has expired. If the high pressure switch opens again in this same operating cycle, the unit will go into *manual lockout* condition and the alarm relay circuit will energize. Recycling the wall thermostat resets the manual lockout.

Low Pressure Switch, Bypass, and Lockout Sequence

If the low pressure switch opens for more than 120 seconds, the compressor contactor will de-energize and go into a soft lockout. Regardless the state of the low pressure switch, the contactor will reenergize after the delay on make time delay has expired. If the low pressure switch remains open, or opens again for longer than 120 seconds, the unit will go into manual lockout condition and the alarm relay circuit will energize. Recycling the wall thermostat resets the manual lockout.

Alarm Relay Output

Alarm terminal is output connection for applications where alarm relay is employed. This terminal is powered whenever the compressor is locked out due to HPC or LPC sequences as described.

NOTE: Both high and low pressure switch controls are inherently automatic reset devices. The high pressure switch and low pressure switch cut out and cut in settings are fixed by specific air conditioner unit model. The lockout features, both soft and manual, are a function of the Compressor Control Module.

ADJUSTMENTS

Adjustable Delay on Make and Delay on Break Timer

The potentiometer is used to select Delay on Break time from 30 seconds to 5 minutes. Delay on Make (DOM) timing on power-up and after power interruptions is equal to 2 minutes plus 10% of Delay on Break (DOB) setting:

0.5 minute (30 seconds)	DOB = 123 second	DOM
1.0 minute (60 seconds)	DOB = 126 second	DOM
2.0 minute (120 seconds)	DOB = 132 second	DOM
3.0 minute (180 seconds)	DOB = 138 second	DOM
4.0 minute (240 seconds)	DOB = 144 second	DOM
5.0 minute (300 seconds)	DOB = 150 second	DOM

During routine operation of the unit with no power interruptions the compressor will operate on demand with no delay.

Typical Settings for Dual Unit Installation:

Unit 1: DOB set at 2 minutes, and DOM is 132 seconds

Unit 2: DOB set at 4 minutes, and DOM is 144 seconds

PRESSURE SERVICE PORTS

High and low pressure service ports are installed on all units so that the system operating pressures can be observed. A pressure table can be found later in the manual covering all models. It is imperative to match the correct pressure table to the unit by model number. See Table 3.

TROUBLESHOOTING

FAN BLADE SETTING DIMENSIONS

Shown in Figure 8 is the correct fan blade setting for proper air delivery across the outdoor coil. Refer to Table 1 for unit specific dimension.

Any service work requiring removal or adjustment in the fan and/or motor area will require that the dimensions below be checked and blade adjusted in or out on the motor shaft accordingly.

**FIGURE 8
FAN BLADE SETTING**

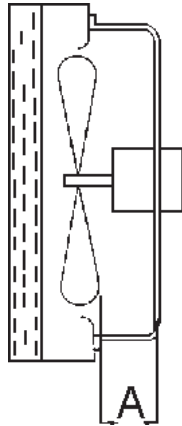

MIS-1724

**TABLE 1
FAN BLADE DIMENSION**

Model	Dimension A
W18A1 / W18L1 W24A1 / W24L1	1.00"
W30A1 / W30L1 W36A1 / W36L1	1.25"
W42A1 / W42L1 W48A1 / W48L1 W60A1 / W60L1	1.75"

REFRIGERANT CHARGE

The correct system R-410A charge is shown on the unit rating plate. Optimum unit performance will occur with a refrigerant charge resulting in a suction line temperature (6" from compressor) as shown in Table 2. If charge quantity is in doubt, reclaim unit and recharge to factory nameplate quantity.

**TABLE 2
REFRIGERANT CHARGE**

Model	Rated Airflow	95°F OD Temperature	82°F OD Temperature
W18A1 / W18L1	600	61 - 65	62 - 66
W24A1 / W24L1	800	56 - 60	56 - 60
W30A1 / W30L1	1000	57 - 61	57 - 61
W36A1 / W36L1	1100	56 - 60	57 - 61
W42A1 / W42L1	1400	58 - 62	60 - 64
W48A1 / W48L1	1550	63 - 67	65 - 69
W60A1 / W60L1	1650	63 - 67	64 - 68

The suction line temperatures in Table 2 above are based upon 80°F dry bulb / 67°F wet bulb (50% R.H.) temperature and rated airflow across the evaporator during cooling cycle.

REMOVAL OF FAN SHROUD

1. Disconnect all power to the unit.
2. Remove the screws holding both grilles, one on each side of unit, and remove grilles.
3. Remove screws holding fan shroud to condenser and bottom. Nine (9) screws.
4. Unwire condenser fan motor.
5. Slide complete motor, fan blade, and shroud assembly out the left side of the unit.
6. Service motor/fan as needed.
7. Reverse steps to reinstall.

**TABLE 3
COOLING PRESSURE TABLE**

Air Temperature Entering Outdoor Coil °F

Model	Return Air Temperature	Pressure	75	80	85	90	95	100	105	110	115	120
W18A1/L1	75 deg. DB 62 deg. WB	Low Side High Side	127 295	129 316	131 337	133 360	135 383	137 407	138 432	140 457	141 484	143 511
	80 deg. DB 67 deg. WB	Low Side High Side	136 303	138 324	140 346	142 369	144 393	146 417	148 443	150 469	151 496	153 524
	85 deg. DB 72 deg. WB	Low Side High Side	141 314	143 335	145 358	147 382	149 407	151 432	153 459	155 485	156 513	158 542
W24A1/L1	75 deg. DB 62 deg. WB	Low Side High Side	121 326	123 350	125 375	127 401	130 426	132 450	134 477	135 502	137 527	138 553
	80 deg. DB 67 deg. WB	Low Side High Side	129 334	132 359	134 385	136 411	139 437	141 462	143 489	144 515	146 541	148 567
	85 deg. DB 72 deg. WB	Low Side High Side	134 346	137 372	139 398	141 425	144 452	146 478	148 506	149 533	151 560	153 587
W30A1/L1	75 deg. DB 62 deg. WB	Low Side High Side	121 335	122 357	125 380	127 404	130 429	132 454	134 481	136 509	137 537	138 566
	80 deg. DB 67 deg. WB	Low Side High Side	129 344	131 366	134 390	136 414	139 440	141 466	143 493	145 522	146 551	148 581
	85 deg. DB 72 deg. WB	Low Side High Side	134 356	136 379	139 404	141 428	144 455	146 482	148 510	150 540	151 570	153 601
W36A1/L1	75 deg. DB 62 deg. WB	Low Side High Side	123 350	125 372	127 396	129 420	131 445	133 470	136 496	138 524	140 552	143 581
	80 deg. DB 67 deg. WB	Low Side High Side	132 359	134 382	136 406	138 431	140 456	142 482	145 509	148 537	150 566	153 596
	85 deg. DB 72 deg. WB	Low Side High Side	137 372	139 395	141 420	143 446	145 472	147 499	150 527	153 556	155 586	158 617
W42A1/L1	75 deg. DB 62 deg. WB	Low Side High Side	128 341	130 362	132 383	133 406	135 429	137 453	138 480	140 506	142 534	144 564
	80 deg. DB 67 deg. WB	Low Side High Side	137 350	139 371	141 393	142 416	144 440	146 465	148 492	150 519	152 548	154 578
	85 deg. DB 72 deg. WB	Low Side High Side	142 362	144 384	146 407	147 431	149 455	151 481	153 509	155 537	157 567	159 598
W48A1/L1	75 deg. DB 62 deg. WB	Low Side High Side	125 349	127 370	129 391	131 415	133 440	136 467	137 495	140 526	143 557	146 590
	80 deg. DB 67 deg. WB	Low Side High Side	134 358	136 379	138 401	140 426	142 451	145 479	147 508	150 539	153 571	156 605
	85 deg. DB 72 deg. WB	Low Side High Side	139 371	141 392	143 415	145 441	147 467	150 496	152 526	155 558	158 591	161 626
W60A1/L1	75 deg. DB 62 deg. WB	Low Side High Side	126 352	128 373	130 396	132 418	133 442	135 466	137 491	137 517	139 544	141 571
	80 deg. DB 67 deg. WB	Low Side High Side	135 361	137 383	139 406	141 429	142 453	144 478	146 504	147 530	149 558	151 586
	85 deg. DB 72 deg. WB	Low Side High Side	140 374	142 396	144 420	146 444	147 469	149 495	151 522	152 549	154 578	156 607

Low side pressure ± 2 PSIG

High side pressure ± 5 PSIG

Tables are based upon rated CFM (airflow) across the evaporator coil. If there is any doubt as to correct operating charge being in the system, the charge should be removed, system evacuated and recharged to serial plate charge weight.

NOTE: Pressure table based on high speed condenser fan operation. If condensing pressures appear elevated check condenser fan wiring. See "Condenser Fan Operation".

TABLE 4

Electrical Specifications — W**A Series														
Model	Rated Volts and Phase	No. Field Power Circuits	Single Circuit				Dual Circuit							
			① Minimum Circuit Ampacity	② Maximum External Fuse or Ckt. Brkr.	③ Field Power Wire Size	④ Ground Wire	⑤ Minimum Circuit Ampacity		⑥ Maximum External Fuse or Ckt. Brkr.		⑦ Field Power Wire Size		⑧ Ground Wire Size	
							Ckt. A	Ckt. B	Ckt. A	Ckt. B	Ckt. A	Ckt. B	Ckt. A	Ckt. B
W18A1 - A00, A0Z	230/208-1	1	16	20	12	12								
A05		1	30	30	10	10								
A08		1	46	50	8	10								
A10		1	56	60	6	10								
W24A1 - A00, A0Z	230/208-1	1	21	30	10	10								
A05		1	30	30	10	10								
A08		1	46	50	8	10								
A10		1	56	60	6	10								
W24A1 - B00, B0Z	230/208-3	1	15	15	14	14								
B06		1	22	25	10	10								
W24A1 - C00, C0Z	460-3	1	10	15	14	14								
C06		1	12	15	14	14								
W30A1 - A00*, A0Z*	230/208-1	1	24	35	8	10								
A05*		1	32	35	8	10								
A08		1	48	50	8	10								
A10*		1	58	60	6	10								
A15		1 or 2	84	90	4	8	58	26	60	30	6	10	10	10
W30A1 - B00*, B0Z*	230/208-3	1	18	20	12	12								
B06		1	24	25	10	10								
B09*		1	33	35	8	10								
B15		1	51	60	8	10								
W30A1 - C00*, C0Z*	460-3	1	11	15	14	14								
C06		1	12	15	14	14								
C09*		1	17	20	12	12								
C15		1	26	30	10	10								
W36A1 - A00*, A0Z*	230/208-1	1	29	35	8	10								
A05*		1	32	35	8	10								
A08		1	48	50	8	10								
A10*		1	58	60	6	10								
A15		1 or 2	84	90	4	8	58	26	60	30	6	10	10	10
W36A1 - B00*, B0Z*	230/208-3	1	23	30	10	10								
B06		1	24	30	10	10								
B09*		1	33	35	8	10								
B15		1	51	60	6	10								
W36A1 - C00*, C0Z*	460-3	1	12	15	14	14								
C06		1	12	15	14	14								
C09*		1	17	20	10	10								
C15		1	26	30	10	10								
W42A1 - A00, A0Z	230/208-1	1	33	50	8	10								
A05		1	33	50	8	10								
A10		1	59	60	6	10								
A15		1 or 2	85	90	4	8	59	26	60	30	6	10	10	
A20		1 or 2	111	125	2	6	59	52	60	60	6	6	10	10
W42A1 - B00, B0Z	230/208-3	1	25	35	8	10								
B09		1	34	35	8	10								
B15		1	53	60	6	10								
B18		1	62	70	6	8								
W42A1 - C00, C0Z	460-3	1	13	15	14	14								
C09		1	18	20	12	12								
C15		1	27	30	10	10								
W48A1 - A00, A0Z	230/208-1	1	37	50	8	10								
A05		1	37	50	8	10								
A10		1	59	60	6	10								
A15		1 or 2	85	90	4	8	59	26	60	30	6	10	10	
A20		1 or 2	111	125	2	6	59	52	60	60	6	6	10	10
W48A1 - B00, B0Z		230/208-3	1	29	40	8	10							
B09	1		34	40	8	10								
B15	1		52	60	6	10								
B18	1		62	70	6	8								
W48A1 - C00, C0Z	460-3	1	14	20	12	12								
C09		1	18	20	12	12								
C15		1	27	30	10	10								
W60A1 - A00, A0Z	230/208-1	1	41	60	8	10								
A05		1	41	60	8	10								
A10		1	59	60	6	10								
A15		1 or 2	85	90	4	8	59	26	60	30	6	10	10	
A20		1 or 2	111	125	2	6	59	52	60	60	6	6	10	10
W60A1 - B00, B0Z	230/208-3	1	28	40	8	10								
B09		1	34	40	8	10								
B15		1	53	60	6	10								
B18		1	62	70	6	10								
W60A1 - C00, C0Z	460-3	1	15	20	12	12								
C09		1	18	20	12	12								
C15		1	27	30	10	10								

- ① Maximum size of the time delay fuse or HACR type circuit breaker for protection of field wiring conductors.
- ② Based on 75C copper wire. All wiring must conform to the National Electrical Code and all local codes.
- ③ These "Minimum Circuit Ampacity" values are to be used for sizing the field power conductors. Refer to the National Electrical code (latest version), Article 310 for power conductor sizing.

Caution: When more than one field power circuit is run through one conduit, the conductors must be derated. Pay special attention to note 8 of Table 310 regarding Ampacity Adjustment Factors when more than three (3) current carrying conductors are in a raceway.

* Top outlet supply option is available only factory installed and only on the selected models.

IMPORTANT: While this electrical data is presented as a guide, it is important to electrically connect properly sized fuses and conductor wires in accordance with the National Electrical Code and all local codes.

TABLE 5

Electrical Specifications — WL Series**

Model	Rated Volts and Phase	No. Field Power Circuits	Single Circuit				Dual Circuit											
			Ⓢ Minimum Circuit Ampacity	Ⓢ Maximum External Fuse or Ckt. Brkr.	Ⓢ Field Power Wire Size	Ⓢ Ground Wire	Ⓢ Minimum Circuit Ampacity		Ⓢ Maximum External Fuse or Ckt. Brkr.		Ⓢ Field Power Wire Size		Ⓢ Ground Wire Size					
							Ckt. A	Ckt. B	Ckt. A	Ckt. B	Ckt. A	Ckt. B	Ckt. A	Ckt. B				
W18L1 - A00, A0Z	230/208-1	1	16	20	12	12												
A05		1	30	30	10	10												
A08		1	46	50	8	10												
A10		1	56	60	6	10												
W24L1 - A00, A0Z	230/208-1	1	21	30	10	10												
A05		1	30	30	10	10												
A08		1	46	50	8	10												
A10		1	56	60	6	10												
W24L1 - B00, B0Z	230/208-3	1	15	15	14	14												
B06		1	22	25	10	10												
W30L1 - A00*, A0Z*	230/208-1	1	24	35	8	10												
A05*		1	32	35	8	10												
A08		1	48	50	8	10												
A10*		1	58	60	6	10												
A15		1 or 2	84	90	4	8	58	26	60	30	6	10	10	10				
W30L1 - B00*, B0Z*	230/208-3	1	18	20	12	12												
B09*		1	33	35	8	10												
B15		1	51	60	8	10												
W30L1 - C00*, C0Z*	460-3	1	11	15	14	14												
C09*		1	17	20	12	12												
C15		1	26	30	10	10												
W36L1 - A00*, A0Z*	230/208-1	1	29	35	8	10												
A05*		1	32	35	8	10												
A10*		1	58	60	6	10												
A15		1 or 2	84	90	4	8	58	26	60	30	6	10	10	10				
W36L1 - B00*, B0Z*	230/208-3	1	23	30	10	10												
B09*		1	33	35	8	10												
B15		1	51	60	6	10												
W36L1 - C00*, C0Z*	460-3	1	12	15	14	14												
C09*		1	17	20	10	10												
C15		1	26	30	10	10												
W42L1 - A00, A0Z	230/208-1	1	33	50	8	10												
A05		1	33	50	8	10												
A10		1	59	60	6	10												
A15		1 or 2	85	90	4	8	59	26	60	30	6	10	10	10				
W42L1 - B00, B0Z	230/208-3	1	25	35	8	10												
B09		1	34	35	8	10												
B15		1	53	60	6	10												
W42L1 - C00, C0Z	460-3	1	13	15	14	14												
C09		1	18	20	12	12												
C15		1	27	30	10	10												
W48L1 - A00, A0Z	230/208-1	1	37	50	8	10												
A05		1	37	50	8	10												
A10		1	59	60	6	10												
A15		1 or 2	85	90	4	8	59	26	60	30	6	10	10	10				
W48L1 - B00, B0Z	230/208-3	1	29	40	8	10												
B09		1	34	40	8	10												
B15		1	52	60	6	10												
W48L1 - C00, C0Z	460-3	1	14	20	12	12												
C09		1	18	20	12	12												
C15		1	27	30	10	10												
W60L1 - A00, A0Z	230/208-1	1	41	60	8	10												
A05		1	41	60	8	10												
A10		1	59	60	6	10												
A15		1 or 2	85	90	4	8	59	26	60	30	6	10	10	10				
W60L1 - B00, B0Z	230/208-3	1	28	40	8	10												
B09		1	34	40	8	10												
B15		1	53	60	6	10												
W60L1 - C00, C0Z	460-3	1	15	20	12	12												
C09		1	18	20	12	12												
C15		1	27	30	10	10												

- ① Maximum size of the time delay fuse or HACR type circuit breaker for protection of field wiring conductors.
- ② Based on 75C copper wire. All wiring must conform to the National Electrical Code and all local codes.
- ③ These "Minimum Circuit Ampacity" values are to be used for sizing the field power conductors. Refer to the National Electrical code (latest version), Article 310 for power conductor sizing.

Caution: When more than one field power circuit is run through one conduit, the conductors must be derated. Pay special attention to note 8 of Table 310 regarding Ampacity Adjustment Factors when more than three (3) current carrying conductors are in a raceway.

* Top outlet supply option is available only factory installed and only on the selected models.

IMPORTANT: While this electrical data is presented as a guide, it is important to electrically connect properly sized fuses and conductor wires in accordance with the National Electrical Code and all local codes.

**TABLE 6
RECOMMENDED AIRFLOW**

Model	Rated CFM *	Rated ESP *	Recommended Airflow Range	Factory Speed Connection
W18A, W18L	550	.40	575 - 725	High
W24A, W24L	800	.20	700 - 950	High
W30A, W30L	1000	.40	930 - 1300	High
W36A, W36L	1100	.30	930 - 1350	High
W42A, W42L	1400	.30	1600 - 1150	High
W48A, W48L	1550	.20	1750 - 1285	High
W60A, W60L	1650	.30	1950 - 1375	High

* Rated CFM and ESP on high speed tap.

**TABLE 7
INDOOR BLOWER PERFORMANCE**

E.S.P. In H ₂ O	W18A/L, W24A/L		W30A/L, W36A/L				W42A/L, W48A/L				W60A/L			
	High Speed		High Speed		Low Speed		High Speed		Low Speed		High Speed		Low Speed	
	Dry Coil	Wet Coil	Dry Coil	Wet Coil	Dry Coil	Wet Coil	Dry Coil	Wet Coil	Dry Coil	Wet Coil	Dry Coil	Wet Coil	Dry Coil	Wet Coil
.0	1020	975	1395	1315	950	935	1885	1800	1650	1600	2200	2000	1600	1450
.1	960	905	1340	1270	930	915	1770	1665	1550	1500	2100	1900	1525	1375
.2	865	800	1285	1190	910	885	1635	1540	1450	1400	2000	1800	—	—
.3	820	735	1205	1100	855	830	1500	1400	1350	1300	1875	1700	—	—
.4	735	650	1110	1000	800	755	1370	1285	1300	1175	1775	1600	—	—
.5	615	535	1005	870	—	—	1250	1150	—	—	1650	1475	—	—

**TABLE 8
MAXIMUM ESP OF OPERATION
ELECTRIC HEAT ONLY**

Model	W18A/L, W24A/L	W30A/L, W36A/L				W42A/L, W48A/L		W60A/L	
Outlet	FRONT	FRONT		TOP		FRONT		FRONT	
Speed	Single	High	Low	High	Low	High	Low	High	Low
-A0Z	.50	.50	.50	.50	.50				
-A04				.50	.45				
-A05	.50	.50	.50			.50	.50	.50	.50
-A08	.50	.50	.50						
-A10		.50	.45	.50	.35	.50	.50	.50	.50
-A15		.40	.35			.50	.50	.50	.50
-A20						.50	.45	.50	.40
-B0Z	.50	.50	.50	.50	.50	.50	.50	.50	.50
-B06	.50	.50	.40						
-B09		.50	.50	.45	.40	.50	.50	.50	.50
-B15		.45	.30			.50	.50	.50	.50
-B18						.50	.50	.50	.50
-C0Z		.50	.50	.50	.50				
-C06		.50	.50						
-C09		.50	.40	.45	.40	.50	.50	.50	.50
-C15		.45	.35			.50	.50	.50	.50

Values shown are for units equipped with standard 1-inch throwaway filter or 1-inch washable filter. Derate ESP by .15 for 2-inch pleated filters.

**TABLE 9
ELECTRIC HEAT**

Models	240V-1		208V-1		240V-3		208V-3		460V-3		
	KW	Amps	BTUH	Amps	BTUH	Amps	BTUH	Amps	BTUH	Amps	BTUH
4	16.7	13650	14.4	10240							
5	20.8	17065	18.1	12800							
6					14.4	20500	12.5	15360	7.2	20500	
8	33.3	27300	28.8	20475							
9					21.7	30600	18.7	23030	10.8	30700	
10	41.6	34130	36.2	25600							
12									14.4	40950	
15	62.5	51250	54.0	38400	36.2	51200	31.2	38400	18.0	51200	
18					43.3	61430	37.5	46100			
20	83.2	68260	72.1	51200							

**TABLE 10
OPTIONAL ACCESSORIES**

Part Number	W18*1-A	W24*1-A	W24*1-B	W24*1-C	W30*1-A	W30*1-B	W30*1-C	W36*1-A	W36*1-B	W36*1-C	W42*1-A	W42*1-B	W42*1-C	W48*1-A	W48*1-B	W48*1-C	W60*1-A	W60*1-B	W60*1-C	
HEATER KITS	EHWA02-A05	X	X																	
	EHW02A-A08	X	X																	
	EHWA02A-A10	X	X																	
	EHWA24-B06			X																
	EHWH24B-C06				X															
	EHWA03-A05					X			X											
	EHWA03-A08					X			X											
	EHWA03-A10					X			X											
	EHWA03-A15					X			X											
	EHWA03-B06						X													
	EHW36A-B06									X										
	EHWA03-B09						X			X										
	EHWA37-B15						X			X										
	EHWC03A-C06							X			X									
	EHWC03A-C09							X			X									
	EHWA03A-C15							X			X									
	EHWA05-A05											X			X					
	EHWA05-A10											X			X			X		
	EHWA05-A15											X			X			X		
	EHWA05-A20											X			X			X		
	EHWA05-B09												X			X				
	EHWA05-B15												X			X			X	
	EHW05A-B18												X			X			X	
	EHWA05A-C09													X			X			X
	EHWA05A-C15													X			X			X
	EHWA60-A05																	X		
EHWA60-B09																		X		
CIRCUIT BREAKER (WMCB) & PULL DISCONNECT (WMPD)	WMCB-01B			X																
	WMCB-02A	X																		
	WMCB-02B						X													
	WMCB-03A		X																	
	WMCB-04B								X											
	WMCB-05A					X			X											
	WMCB-05B										X				X					
	WMCB-06B																		X	
	WMCB-08A											X			X					
	WMCB-09A																	X		
	WMPD-01C				X			X			X			X			X			X

**TABLE 11
VENT & CONTROL OPTIONS**

Part Number	Description	W18, W24	W30, W36	W42, W48, W60
CMC-14	ODT	X	X	X
CMC-15	Start Kit (230V 1-Phase)	X	X	X
CMC-23	DDC	X	X	
CMC-24	DDC			X
CMC-28	LAC	X	X	X
BFAD-2	Barometric Fresh Air Damper - Standard	X		
BOP-2	Blank Off Plate	X		
MFAD-2	Motorized Fresh Air Damper	X		
CRV-2	Commercial Ventilator - Spring Return	X		
EIFM-2B	Economizer	X		
WERV-A2B	Energy Recovery Ventilator - 230 Volt		X	
BFAD-3	Barometric Fresh Air Damper - Standard		X	
BOP-3	Blank Off Plate		X	
MFAD-3	Motorized Fresh Air Damper		X	
CRVS-3	Commercial Ventilator - Spring Return		X	
CRVP-3	Commercial Ventilator - Power Return		X	
EIFM-3C	Economizer		X	
WERV-A3C	Energy Recovery Ventilator - 230 Volt		X	
WERV-C3C	Energy Recovery Ventilator - 460 Volt		X	
BFAD-5	Barometric Fresh Air Damper - Standard			X
BOP-5	Blank Off Plate			X
MFAD-5	Motorized Fresh Air Damper			X
CRVS-5	Commercial Ventilator - Spring Return			X
CRVP-5	Commercial Ventilator - Power Return			X
EIFM-5C	Economizer			X
WERV-A5C	Energy Recovery Ventilator - 230 Volt			X
WERV-C5C	Energy Recovery Ventilator - 460 Volt			X