

---

# INSTALLATION INSTRUCTIONS

---

## TEC40 ELECTRONIC CONTROLLER



CLIMATE CONTROL SOLUTIONS

BARD MANUFACTURING COMPANY  
Bryan, Ohio 43506  
*Since 1914...Moving ahead, just as planned.*

Manual: 2100-393  
Supersedes:  
File: Volume III Tab 19  
Date: 05-17-01

# CONTENTS

---

Shipping Damage .....	1
General .....	1
Theory of Operation .....	1
Lead-Lag Change Over Time .....	1
Modes of Operation .....	1
Installation Instructions .....	3
Fire Suppression Circuit .....	3
Adjustments .....	4

## Figures

Figure 1 Control Locations .....	5
Figure 2 Four Unit Mode .....	6
With and Without Economizers	
Figure 3 Three Unit Mode .....	7
With and Without Economizers	
Figure 4 Two Unit Mode With Economizers .....	8
Figure 5 Two Unit Mode Without Economizers .....	9

## **\*\* IMPORTANT \*\***

The equipment covered in this manual is to be installed by trained, experienced service and installation technicians. Please read entire manual before proceeding.

### **SHIPPING DAMAGE**

Upon receipt of equipment, the carton should be checked for external signs of shipping damage. If damage is found, the receiving party must contact the last carrier immediately, preferably in writing, requesting inspection by the carrier's agent.

### **GENERAL**

These instructions explain the operation, installation and troubleshooting of the TEC40 controller.

All internal wiring is complete. Only attach low voltage field wiring to designated terminal strips.

The controller is for use with up to four (4) Bard air conditioning wall mount series units. The TEC40 is for use with units with or without economizers.

It is recommended that a five (5) minute compressor time delay relay be factory or field installed in each unit.

The TEC40 controller is suitable for both 50 and 60 HZ operation.

### **THEORY OF OPERATION**

The controller is used to control up to four wall mount air conditioners from one thermostat. It provides total redundancy for the structure and equal wear on all units. It can be used with units with economizers but all units must be equipped alike. That is, all must have economizers or all must be without economizers. See Figure 1 for component locations.

### **LEAD-LAG CHANGE OVER TIME**

The lead-lag change over time period is user selectable. Time periods available are 0, 1, 3, 7, 14 and 28 days. Once every time period the lead unit will be advanced to the next unit providing equal wear on the units. For timer speed up, push and hold the change lead unit push-button for one second. Timer speed up is supplied for ease of trouble shooting.

Lead unit cycles between all 4 units in four unit mode; between 1, 2 and 3 in three unit mode; and between units 1 and 2 in both two unit modes.

In the event of a unit(s) failure, the change over time jumper may be set to 0 days. This will prevent the TEC40 from switching lead unit to the next unit. Push the push-button to make a functional unit the lead unit if necessary. If power is lost the controller will remember which unit was the lead unit when power is reapplied.

### **MODES OF OPERATION**

The TEC40 has four modes of operation.

1. Four Unit Mode
2. Three Unit Mode
3. Two Unit Alternating Mode
4. Two Unit Non-Alternating Mode.

### **STAGING DELAY PERIODS**

The following delays are built in for both cooling and heating: stage 1 – 0 seconds; stage 2 – 10 seconds; stage 3 – 15 seconds; and stage 4 – 20 seconds. The delays are active anytime there is a power interruption or the controller ON-OFF switch is exercised.

### **FOUR UNIT MODE**

In four unit mode the TEC40 will control four air-conditioners with or without economizers. Make connections per Figure 2 on Page 6.

#### **Sequence of Operation – Cooling**

First stage cooling set point is determined by the position of the cooling set point potentiometer. On a call for first stage cooling, the blower and either economizer or compressor of the lead unit is energized. The enthalpy control on the economizer will make the decision as to which is energized. If not equipped with economizers the compressor will energize. First stage cooling LED will light.

Second stage cooling set point is 2.0 degrees warmer than first stage cooling set point. On a call for second stage cooling, the blower and either economizer or compressor of the next unit is energized. The enthalpy control on the economizer will make the decision as to which is energized. If not equipped with economizer the compressor will energize. Second stage cooling LED will light.

Third stage cooling set point is 2.0 degrees warmer than second stage cooling set point. On a call for third stage cooling, the blower and either economizer is energized. The enthalpy control on the economizer will make the decision as to which is energized. If not equipped with economizer the compressor will energize. Third stage cooling LED will light.

Fourth stage cooling set point is 2.0 degrees warmer than third stage cooling set point. On a call for fourth stage cooling, the blower and either economizer or compressor of the next unit is energized. The enthalpy control on the economizer will make the decision as to which is energized. If not equipped with economizer the compressor will energize. Fourth stage cooling LED will light.

### **Sequence of Operation – Heating**

First stage heating set point is determined by subtracting the dead band setting from cooling set point setting. For example, if the cooling set point is 74 degrees and the dead band adjustment is set at 4 degrees the heating set point is 70 degrees. On a call for first stage heating, the blower and electric heat of the lead unit is energized. First stage heating LED will light.

Second stage heating set point is 2.0 degrees colder than first stage heating set point. On a call for second stage heating, the blower and electric heat of the next unit is energized. Second stage heating LED will light.

Third stage heating set point is 2.0 degrees colder than second stage heating set point. On a call for third stage heating, the blower and electric heat of the next unit is energized. Third stage heating LED will light.

Fourth stage heating set point is 2.0 degrees colder than third stage heating set point. On a call for fourth stage heating, the blower and electric heat of the next unit is energized. Fourth stage heating LED will light.

### **THREE UNIT MODE**

In three unit mode the TEC40 will control three air conditioners with or without economizers. Make connections per Figure 3 on Page 7.

### **Sequence of Operation**

The cooling and heating sequence of operation are the same as four unit mode except that the fourth stage heating or cooling is not available.

### **TWO UNIT NON-ALTERNATING MODE**

In two unit non-alternating mode the TEC40 will control two air conditioners with two speed or dual compressors. Make connections per Figure 5 on Page 9.

### **Sequence of Operation – Cooling**

First stage cooling set point is determined by the position of the cooling set point potentiometer. On a call for first stage cooling, the blower and low speed or first compressor of the lead unit is energized. First stage cooling LED will light.

Second stage cooling set point is 2.0 degrees warmer than first stage cooling set point. On a call for second stage cooling, the high speed or second compressor of the lead unit will energize. Second stage cooling LED will light.

Third stage cooling set point is 2.0 degrees warmer than second stage cooling set point. On a call for third stage cooling the blower and low speed or first compressor of the lag unit will energize. Third stage cooling LED will light.

Fourth stage cooling set point is 2.0 degrees warmer than third stage cooling set point. On a call for fourth stage cooling, the high speed or second compressor of the lag unit will energize. Fourth stage cooling LED will light.

### **Sequence of Operation – Heating**

First stage heating set point is determined by subtracting the dead bank setting from cooling set point setting. For example, if the cooling set point is 74 degrees and the dead band adjustment is set at 4 degrees the heating set point is 70 degrees. On a call for first stage heating, the blower and electric heat of the lead unit is energized. First stage heating LED will light.

Second stage heating set point is 2.0 degrees colder than first stage heating set point. On a call for second stage heating, the second electric heat (if equipped) of the lead unit is energized. Second stage heating LED will light.

Third stage heating set point is 2.0 degrees colder than second stage heating set point. On a call for third stage heating, the blower and electric heat of the lag unit is energized. Third stage heating LED will light.

Fourth stage heating set point is 2.0 degrees colder than third stage heating set point. On a call for fourth stage heating, the second electric heat (if equipped) of the lag unit is energized. Fourth stage heating LED will light.

### **TWO UNIT ALTERNATING MODE**

In two unit alternating mode the TEC40 will control two air conditioners with two speed or dual compressor or two air conditioners with economizers with full redundancy. Make connections per Figure 4 on Page 8.

### **Sequence of Operation – Cooling with Economizers**

First stage cooling set point is determined by the position of the cooling set point potentiometer. On a call for first stage cooling, the blower and either economizer or compressor of the lead unit is energized. The enthalpy control on the economizer will make the decision as to which is energized. First stage cooling LED will light.

Second stage cooling set point is 2.0 degrees warmer than first stage cooling set point. On a call for second stage cooling, the blower and either economizer or compressor of the lag unit is energized. The enthalpy control on the economizer will make the decision as to which is energized. Second stage cooling LED will light.

Third stage cooling set point is 2.0 degrees warmer than second stage cooling set point. On a call for third stage cooling, the compressor of the lead unit will energize and the economizer will return to minimum position if open. Third stage cooling LED will light.

Fourth stage cooling set point is 2.0 degrees warmer than third stage cooling set point. On a call for fourth stage cooling, the compressor of the lag unit will energized and the economizer will return to minimum position if open. Fourth stage cooling LED will light.

### **Sequence of Operation – Heating**

First stage heating set point is determined by subtracting the dead and setting from cooling set point setting. For example, if the cooling set point is 74 degrees and the dead band adjustment is set at 4 degrees the heating set point is 70 degrees. On a call for first stage heating, the blower and electric heat of the lead unit is energized. First stage heating LED will light.

Second stage heating set point is 2.0 degrees colder than first stage heating set point. On a call for second stage heating, the electric heat of the lag unit is energized. Second stage heating LED will light.

Third stage heating set point is 2.0 degrees colder than second stage heating set point. On a call for third stage heating, the second electric heat (if equipped) of the lead unit is energized. Third stage heating LED will light.

Fourth stage heating set point is 2.0 degrees colder than third stage heating set point. On a call for fourth stage heating, the second electric heat (if equipped) of the lag unit is energized. Fourth stage heating LED will light.

## **INSTALLATION INSTRUCTIONS**

### **MOUNTING**

Included in the controller carton is the controller and installation instructions.

The controller should be installed on a vertical wall approximately four (4) feet above the floor away from drafts and outside doors or windows. Four (4) mounting holes are provided for mounting to the wall, and holes for conduit connections are provided in both the base, side and top of the controller. The controller should not be mounted directly to a block wall; space away from wall with insulation or plywood.

Once mounted, slide the thermistor sensor down into the fitting on the bottom of the TEC40. Position the sensor so that 15/16 inch is protruding from the bottom of the fitting. Tighten the fitting to hold the sensor in position.

### **LOW VOLTAGE FIELD WIRING**

The TEC40 is powered from the air conditioners that it is controlling, low voltage only.

Circuitry in the TEC40 isolate the power supplies of all connected air conditioners so that no back feeds or phasing problems can occur. Additionally if one air conditioner loses power the TEC40 and the other air conditioners are unaffected and will continue to operate normally.

Connect the low voltage field wiring from each unit per the low voltage field wiring diagrams in Figure 2, 3, 4 or 5 depending on the mode of operation desired.

### **FIRE SUPPRESSION CIRCUIT**

To disable the TEC40 and shut down all air conditioners, terminal F1 and F2 may be used. The F1 and F2 terminals must be jumpered together for normal operation. A normally closed set of contacts may be connected across the terminals and the factory jumper removed for use with a field installed fire suppression system. The contacts must open if a fire is detected. Contacts should be rated for pilot duty operation at 2 amp 24 VAC minimum.

## ADJUSTMENTS

See Figure 1.

### COOLING SET POINT

Set the cooling set point in degrees C° or F° as indicated on the front of the TEC20.

### DEAD BAND

The dead band is the span between heating set point and cooling set point where no heating or cooling takes place. The cooling set point minus the dead band equals the heating set point. Adjustable from 4° to 20° F.

### ON/OFF SWITCH – UNDER COVER

This disables the TEC40. This switch must be ON for any heating or cooling to operate.

### CHANGE OVER TIME JUMPER – UNDER COVER

The change over period for the sequence can be adjusted to 0, 1, 3, 7 or 28 days.

If the jumper is set to 7 days (or other selected choice), units will rotate upwards: first to second, second to third, third to fourth, and fourth to first place. If connected for three units then three will go to first, and fourth position is ignored.

The 0 day position is supplied in the event of a unit failure or if only one air conditioner is used with the TEC40. If the unit needs to run for a time and not switch to the lag unit, set the jumper to “0” and push the lead change push-button to make the functional or single unit the lead unit. When the jumper is in the 0 position the lead unit will never switch.

### LEAD CHANGE PUSH-BUTTON – UNDER COVER

Pushing the lead change push-button will immediately change the lead unit to the lag unit. It also resets the lead/lag change over timer.

### TEST MODE JUMPER – UNDER COVER

To test the lead/lag timing, place the jumper across the two pins. The change over time is accelerated to seconds instead of days.

For example, if the change over time jumper is set to 7 days the lead and lag units would switch in 7 seconds. Jumper must be vertical on one (1) pin only for normal operation.

*NOTE: Remove the test jumper immediately upon the controller shifting positions of lead unit. Otherwise the timer will continue to operate in accelerated mode and force another change in the same number of seconds.*

### OPERATION MODE JUMPER – UNDER COVER

Position jumper across pins 4 for four unit mode.  
Position jumper across pins 3 for three unit mode.  
Position jumper across pins 2 for two unit alternating mode. Remove jumper for two unit non-alternating mode.

### CONTINUOUS BLOWER JUMPER – UNDER COVER

Position jumper across pins for continuous blower on the lead unit. Remove jumper to have the lead unit blower cycle with the compressor.

**FIGURE 1  
CONTROL LOCATIONS**

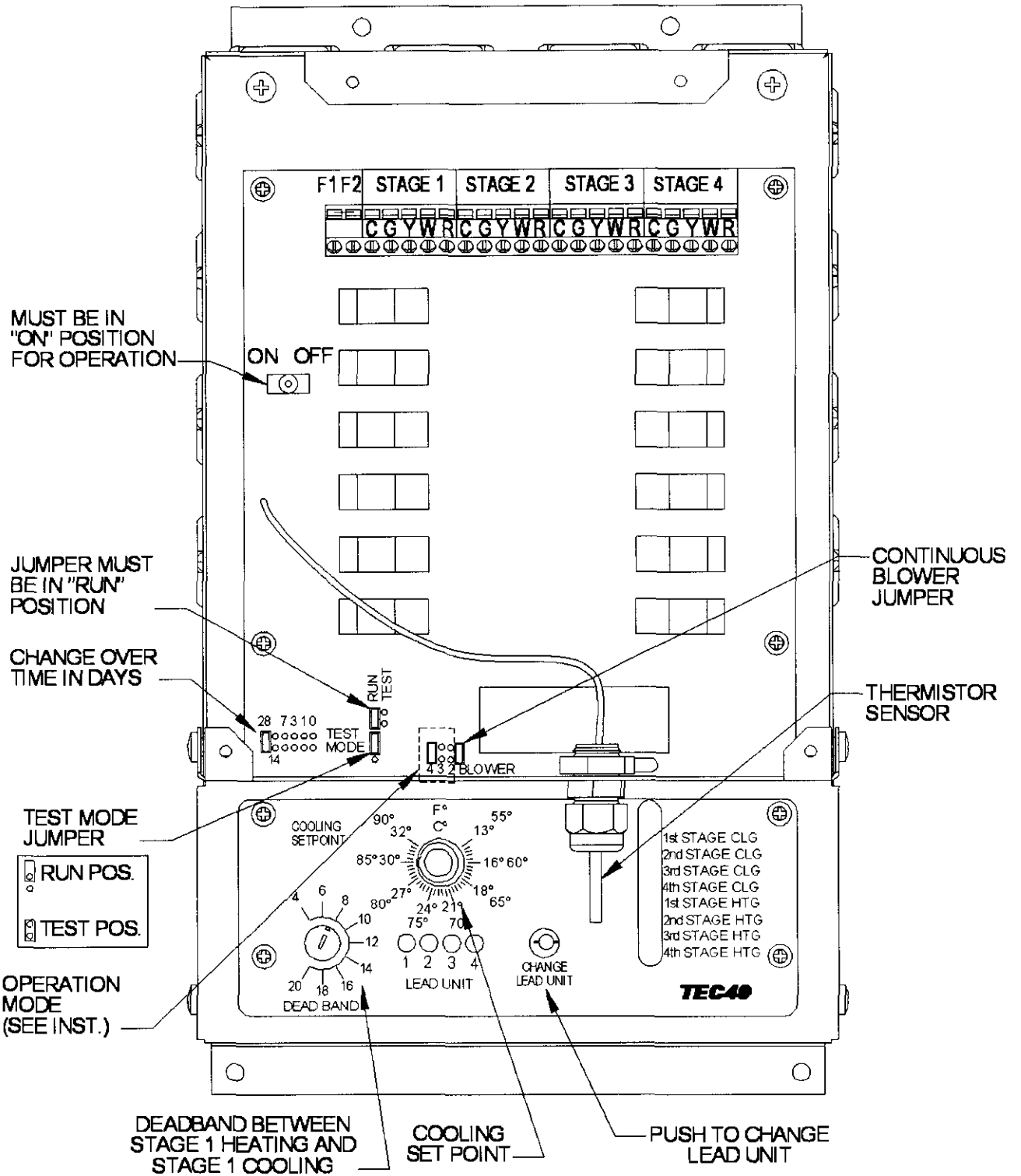

7960-477

FIGURE 2

FOUR UNIT MODE WITH ECONOMIZERS

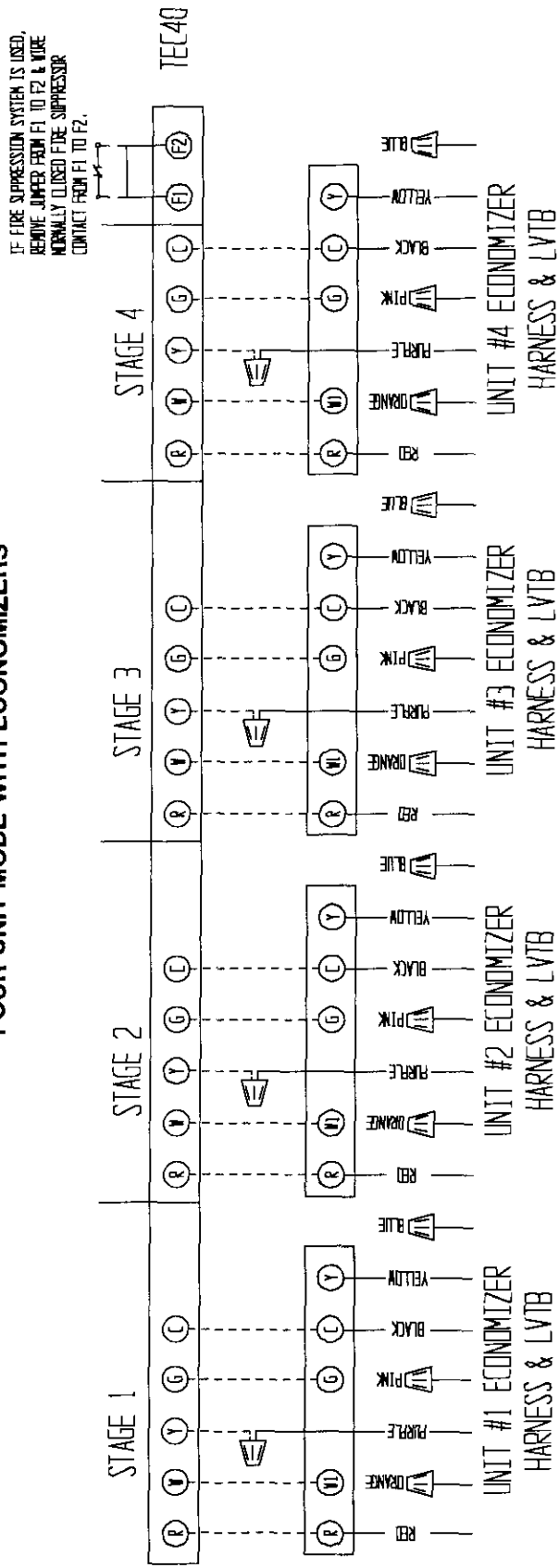

FOUR UNIT MODE WITHOUT ECONOMIZERS

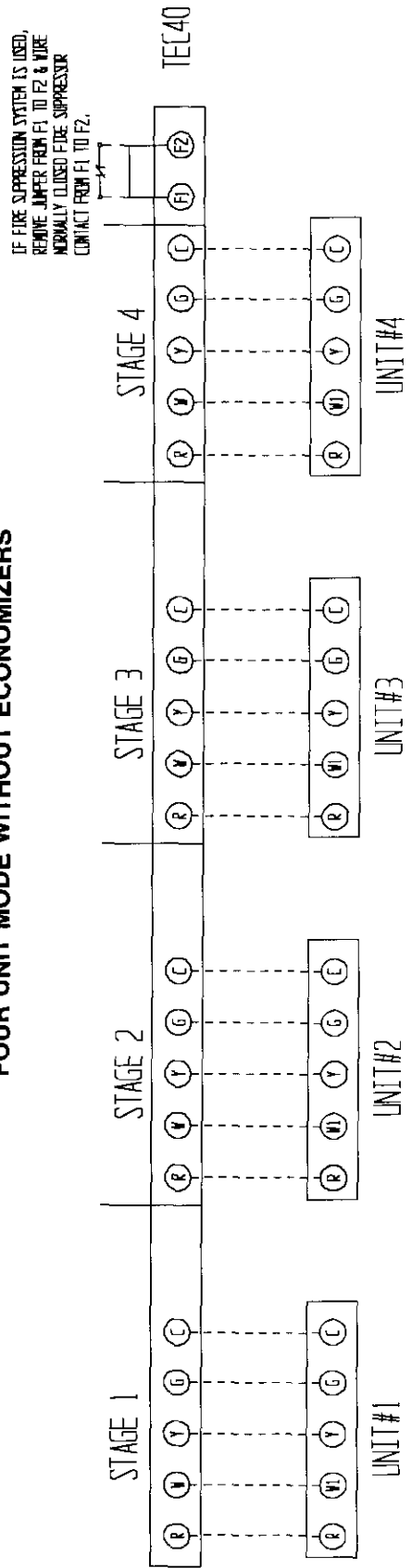
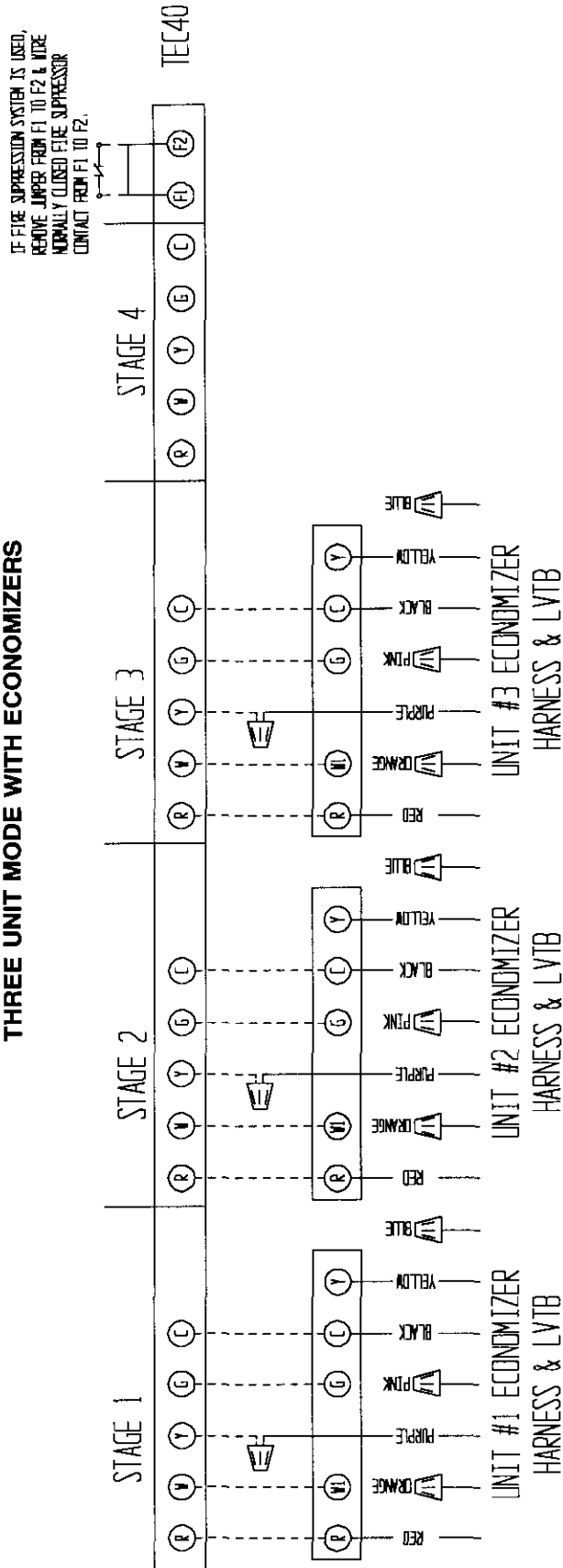



FIGURE 3

THREE UNIT MODE WITH ECONOMIZERS



THREE UNIT MODE WITHOUT ECONOMIZERS

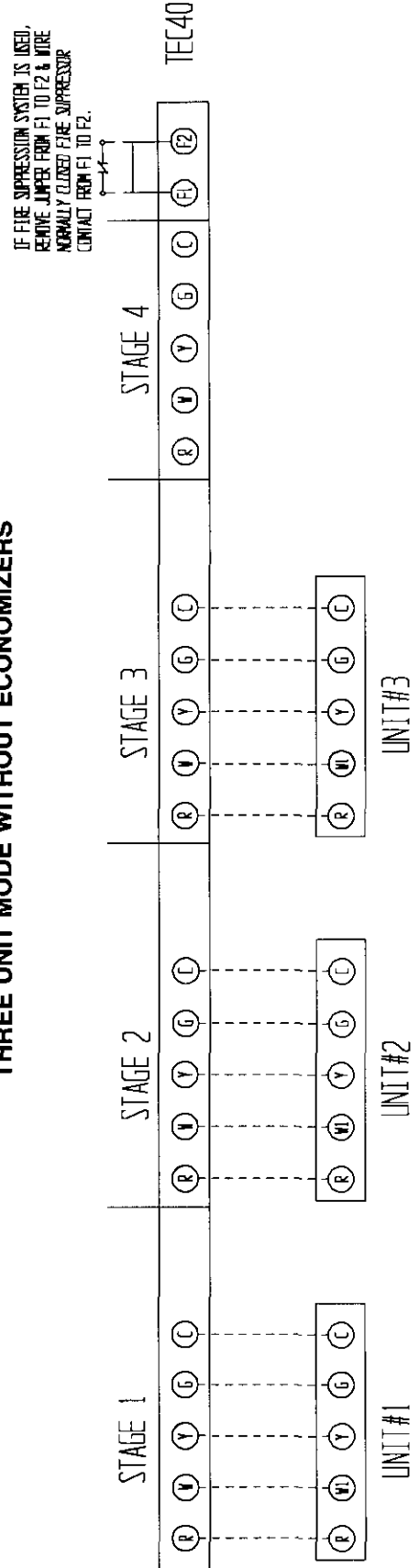

FIGURE 4

TWO UNIT MODE WITH ECONOMIZERS

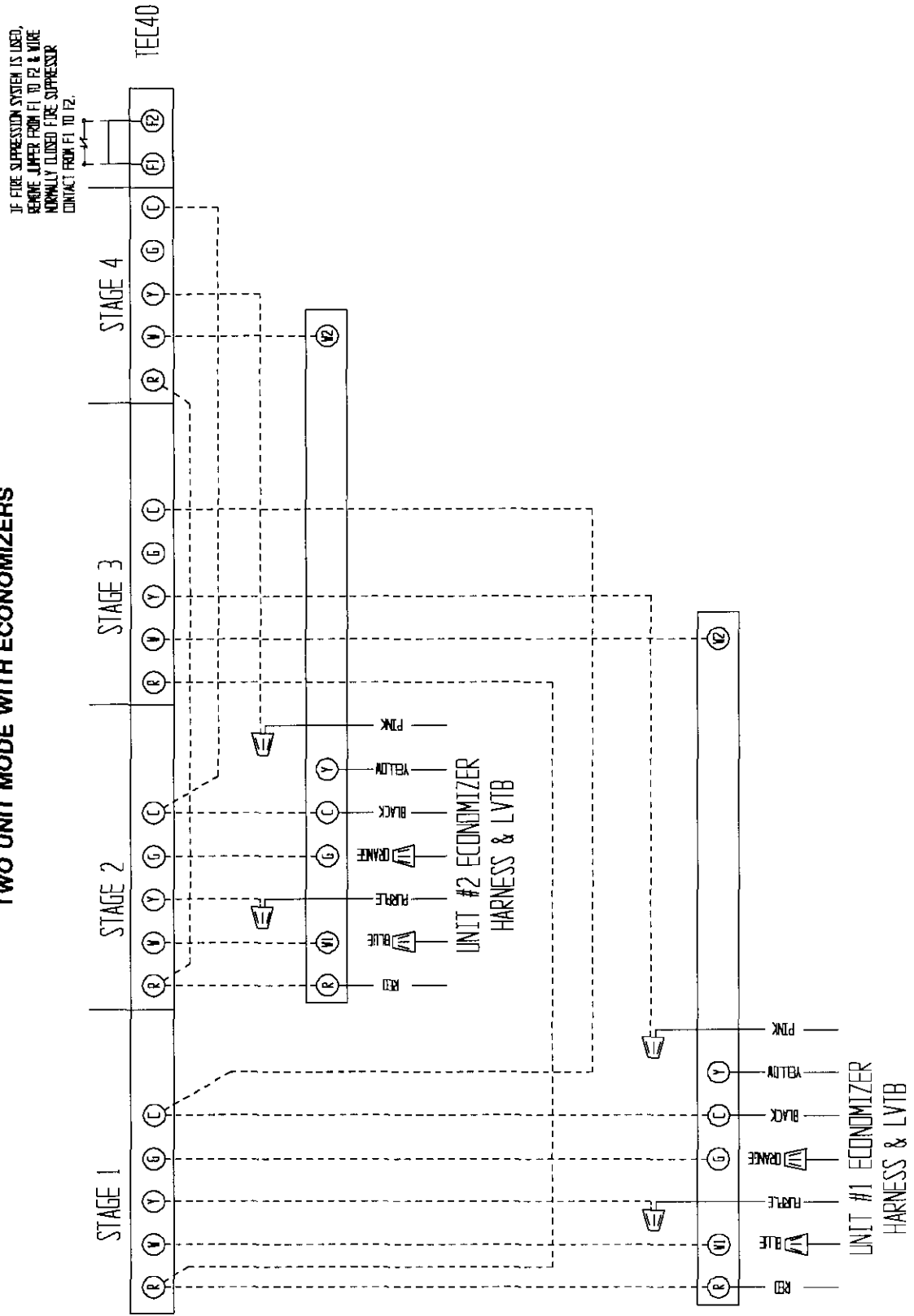
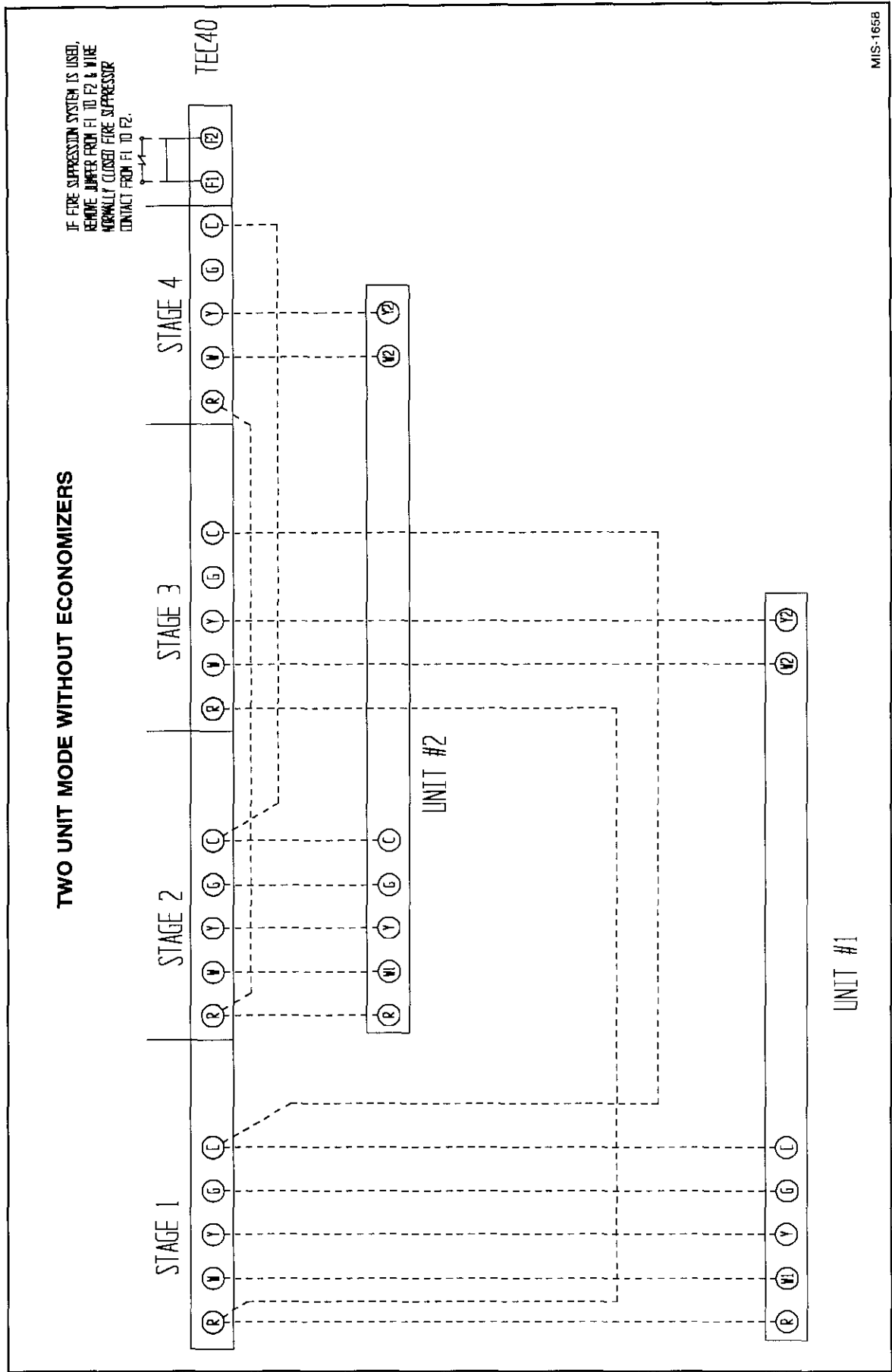

FIGURE 5



MIS-1658