

QTEC Series Packaged Heat Pump

Installation Instructions

Models:
QH241 QH301
QH361 QH421
QH481

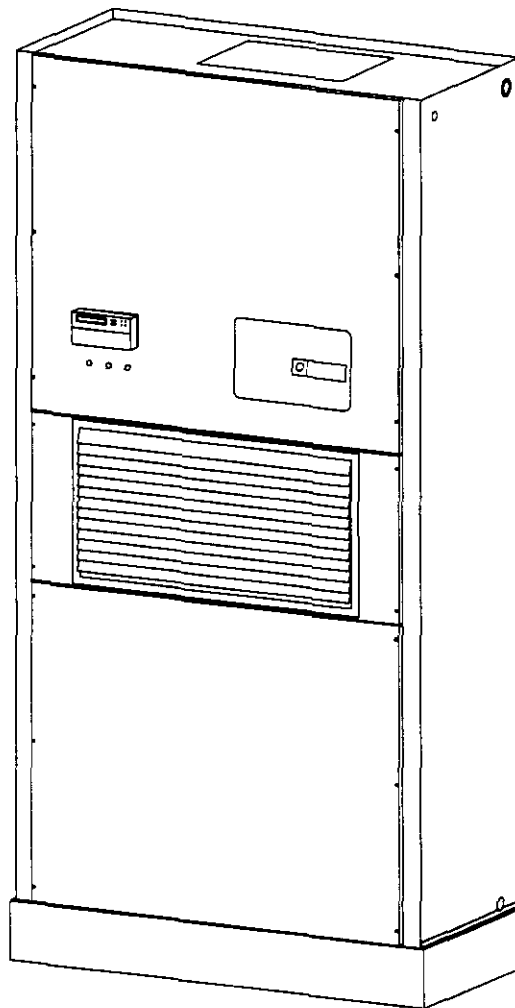

MIS-873



Bard Manufacturing Company
Bryan, Ohio 43506

*Since 1914...Moving ahead, just as
planned.*

Manual No.: 2100-288D
Supersedes: 2100-288C
File: Vol II Tab 14
Date: 09-01-98

© Copyright 1998

Contents

Getting Other Information and Publications	1
For more information, contact these publishers:	1
QTEC General Information	2
QTEC Model Nomenclature	2
Shipping Damage	6
Unit Removal From Skid	6
Handling Unit After Removal From Skid	7
General	7
Minimum Installation Height	7
Duct Work	9
Filters	9
Dirty Filter Switch Adjustment	10
Fresh Air Intake	10
Condensate Drain	10
Service Lights	11
Installation Instructions	12
Mounting the Unit	12
Wiring — Main Power	13
Wiring — Low Voltage Wiring	13

Start Up	18
Description of Standard Equipment	18
Optional CFM (QH361, QH421 and QH481 Only)	18
Important Installer Note	18
Three Phase Scroll Compressor Start Up Information	18
Service Hints	18
Mist Eliminator Service	19
Sequence of Operation	22
Optional Climate Controls Sequenc of Operation	22
Pressure Service Ports	22
Defrost Cycle	23
Troubleshooting	24
Solid State Heat Pump Control Troubleshooting Procedure	24
Checking Temperature Sensor	25
Fan Blade Setting Dimensions	26
Refrigerant Charge	26
Pressure Charts	27
Optional Accessories	28

Figures

Figure 1	Unit Dimensions	5
Figure 2	Air Seal on Bottom of Unit	6
Figure 3	Removal of Unit From Skid	6
Figure 4	Unit on Appliance Cart for Moving	7
Figure 5	Installation With Free Blow Plenum	8
Figure 6	Ducted Application	8
Figure 7	Supply Duct Connections	9
Figure 8	Filter Location	9
Figure 9	Side Drain	10
Figure 10	Optional Rear Drain	10
Figure 11	Rear Drain (Top View)	11
Figure 12	Unit Mounting	11
Figure 13	Unlocking Wheels of Unit	12
Figure 14	Component Location	13
Figure 15	Thermostat Plug Terminals P2	14
Figure 16	Remote Thermostat Wiring Diagram	14
Figure 17	Wiring Diagram	15
Figure 18	Wiring Diagram	16
Figure 19	Wiring Diagram	17
Figure 20	Fresh Air Damper Removal	20
Figure 21	QERV Removal	21
Figure 22	Heat Pump Control Board	23
Figure 23	Fan Blade Setting	24

Tables

Table 1	Factory Built-In Electric Heat Table	2
Table 2	Electrical Specifications	3
Table 2A	Electrical Specifications	4
Table 3	Operating Voltage Range	13
Table 4	Wall Thermostats and Subbase Combinations	14
Table 5	Troubleshooting	24
Table 6	Temperature vs Resistance of Temperature Sensor	25
Table 7	Fan Blade Dimensions	26
Table 8	Suction Line Temperatures	26
Table 9	Indoor Blower Performance	26
Table 10	Cooling Pressure	27
Table 11	Heating Pressure	28

Getting Other Information and Publications

These publications can help you install the air conditioner or heat pump. You can usually find these at your local library or purchase them directly from the publisher. Be sure to consult current edition of each standard.

National Electrical Code ANSI/NFPA 70

Standard for the Installation ANSI/NFPA 90A
of Air Conditioning and
Ventilating Systems

Standard for Warm Air ANSI/NFPA 90B
Heating and Air
Conditioning Systems

Load Calculation for ACCA Manual J or
Winter and Manual N
Summer Air Conditioning

Low Pressure, Low Velocity Duct ACCA Manual D or
System Design for Winter and Manual Q
Summer Air Conditioning

For more information, contact these publishers:

ACCA — Air Conditioning Contractors of America
1712 New Hampshire Avenue
Washington, DC 20009
Telephone: (202) 483-9370
Fax: (202) 234-4721

ANSI — American National Standards Institute
11 West Street, 13th Floor
New York, NY 10036
Telephone: (212) 642-4900
Fax: (212) 302-1286

**ASHRAE — American Society of Heating
Refrigerating, and
Air Conditioning Engineers, Incorporated**
1791 Tullie Circle, N.E.
Atlanta, GA 30329-2305
Telephone: (404) 636-8400
Fax: (404) 321-5478

NFPA — National Fire Protection Association
Batterymarch Park
P.O. Box 9101
Quincy, MA 02269-9901
Telephone: (800) 344-3555
Fax: (617) 984-7057

QTEC Series General Information

QTEC Model Nomenclature

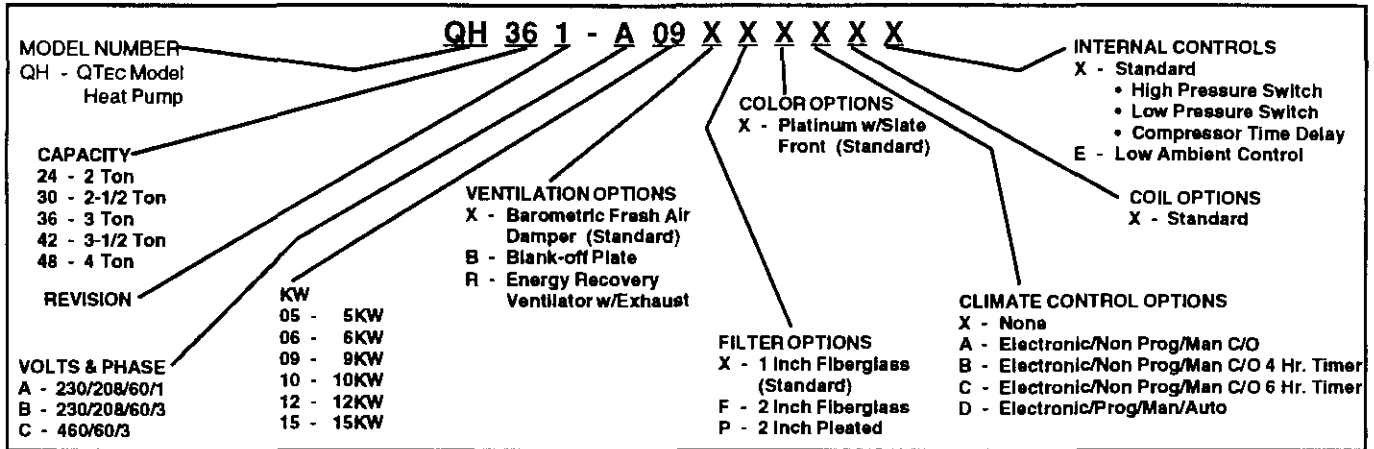

TABLE 1 - FACTORY BUILT-IN ELECTRIC HEAT TABLE

MODELS	QH241-A QH301-A		QH241-B		QH301-B		QH241-C	QH301-C	QH361-A QH421-A QH481-A		QH361-B QH421-B QH481-B		QH361-C QH421-C QH481-C
	240V-1	208V-1	240V-1	208V-1	240V-1	208V-1	480V-3	480V-3	240V-1	208V-1	240V-1	208V-1	480V-3
KW	BTUH	BTUH	BTUH	BTUH	BTUH	BTUH	BTUH	BTUH	BTUH	BTUH	BTUH	BTUH	BTUH
5.0	16,380	12,290							16,380	12,290			
6.0			20,500	15,360	20,500	15,360	20,500	20,500			20,500	15,360	20,500
9.0			30,700	23,000	30,700	23,000	30,700	30,700			30,700	23,000	30,700
10.0	32,670	24,570							32,670	24,570			
12.0					41,000	30,700		41,000					
15.0									49,150	36,860	49,150	36,860	49,150

TABLE 2 ELECTRICAL SPECIFICATIONS

MODEL	RATED VOLTS & PHASE	SINGLE CIRCUIT					DUAL CIRCUIT							
		NO. FIELD POWER CIRCUITS	③ MINIMUM CIRCUIT AMPACITY	① MAXIMUM EXTERNAL FUSE OR CIRCUIT BREAKER	② FIELD POWER WIRE SIZE	② GROUND WIRE SIZE	③ MINIMUM CIRCUIT AMPACITY		① MAXIMUM EXTERNAL FUSE OR CIRCUIT BREAKER		② FIELD POWER WIRE SIZE		② GROUND WIRE SIZE	
							CKT. A	CKT. B	CKT. A	CKT. B	CKT. A	CKT. B	CKT. A	CKT. B
QH241DA0Z DA05 DA10	230/208-1	1	22	30	10	10	-	-	-	-	-	-	-	-
		1	47	50	8	10	-	-	-	-	-	-	-	-
		1 OR 2	72	80	4	8	22	50	30	50	10	8	10	10
QH241DB0Z DB06 DB09	230/208-3	1	16	20	12	12	-	-	-	-	-	-	-	-
		1	34	35	8	10	-	-	-	-	-	-	-	-
		1	43	45	8	10	-	-	-	-	-	-	-	-
QH241DC0Z DC06 DC09	460-3	1	11	15	14	14	-	-	-	-	-	-	-	-
		1	20	20	12	12	-	-	-	-	-	-	-	-
		1	24	25	10	10	-	-	-	-	-	-	-	-
QH301DA0Z DA05 DA10	230/208-1	1	24	35	8	10	-	-	-	-	-	-	-	-
		1	49	50	8	10	-	-	-	-	-	-	-	-
		1 OR 2	74	80	4	8	24	50	30	50	10	8	10	10
QH301DB0Z DB06 DB09 DB12	230/208-3	1	18	25	10	10	-	-	-	-	-	-	-	-
		1	36	40	8	10	-	-	-	-	-	-	-	-
		1	45	45	6	10	-	-	-	-	-	-	-	-
QH301DC0Z DC06 DC09 DC12	460-3	1	12	15	14	14	-	-	-	-	-	-	-	-
		1	22	25	10	10	-	-	-	-	-	-	-	-
		1	26	30	10	10	-	-	-	-	-	-	-	-
QH361DA0Z DA05 DA10 ④ DA15	230/208-3	1	27	35	8	10	-	-	-	-	-	-	-	-
		1	52	60	6	10	-	-	-	-	-	-	-	-
		1 OR 2	77	90	4	8	27	50	40	50	8	8	10	10
⑤ QH361DB0Z DB06 DB09 DB15	230/208-3	1	20	30	10	10	-	-	-	-	-	-	-	-
		1	38	40	8	10	-	-	-	-	-	-	-	-
		1	48	50	8	10	-	-	-	-	-	-	-	-
⑤ QH361DC0Z DC06 DC09 DC15	460-3	1	14	15	14	14	-	-	-	-	-	-	-	-
		1	23	25	10	10	-	-	-	-	-	-	-	-
		1	27	30	10	10	-	-	-	-	-	-	-	-
⑤ QH361DC0Z DC06 DC09 DC15	460-3	1	14	15	14	14	-	-	-	-	-	-	-	-
		1	23	25	10	10	-	-	-	-	-	-	-	-
		1	27	30	10	10	-	-	-	-	-	-	-	-

- ① Maximum size of the time delay fuse or HACR type circuit breaker for protection of field wiring conductors.
- ② Based on 75° C copper wire. All wiring must conform to the National Electrical Code and all local codes.
- ③ These "Minimum Circuit Ampacity" values are to be used for sizing the field power conductors. Refer to the National Electric Code (latest revision), article 310 for power conductor sizing. CAUTION: When more than one field power conductor circuit is run through one conduit, the conductors must be derated. Pay special attention to Note 8 of Table 310 regarding Ampacity Adjustment Factors when more than three conductors are in a raceway.
- ④ Maximum KW that can operate with heat pump on is 10KW. Other 5KW energizes during emergency heating only.
- ⑤ Maximum KW that can operate with heat pump on is 9KW. Other 6KW energizes during emergency heating only.

ELECTRICAL SPECIFICATIONS Continued on Page 4 TABLE 2A

TABLE 2A ELECTRICAL SPECIFICATIONS (continued from Page 3)

MODEL	RATED VOLTS & PHASE	SINGLE CIRCUIT					DUAL CIRCUIT							
		NO. FIELD POWER CIRCUITS	③ MINIMUM CIRCUIT AMPACITY	① MAXIMUM EXTERNAL FUSE OR CIRCUIT BREAKER	② FIELD POWER WIRE SIZE	② GROUND WIRE SIZE	③ MINIMUM CIRCUIT AMPACITY		① MAXIMUM EXTERNAL FUSE OR CIRCUIT BREAKER		② FIELD POWER WIRE SIZE		② GROUND WIRE SIZE	
							CKT. A	CKT. B	CKT. A	CKT. B	CKT. A	CKT. B	CKT. A	CKT. B
QH421-A0Z -A05 -A10 ④ -A15	230/208-1	1 1 1 OR 2 1 OR 2	33 58 83 83	50 60 90 90	8 6 4 4	10 10 8 8	- - 33 33	- - 50 50	- - 40 40	- - 50 50	- - 8 8	- - 8 8	- - 10 10	- - 10 10
QH421-B0Z -B06 -B09 ⑤ -B15	230/208-3	1 1 1 1	22 40 49 52	30 45 50 60	10 8 8 6	10 10 10 10	- - - -	- - - -	- - - -	- - - -	- - - -	- - - -	- - - -	- - - -
QH421-C0Z -C06 -C09 ⑤ -C15	460-3	1 1 1 1	16 25 30 30	20 25 30 30	12 10 10 10	12 10 10 10	- - - -	- - - -	- - - -	- - - -	- - - -	- - - -	- - - -	- - - -
QH481-A0Z -A05 -A10 ④ -A15	230/208-1	1 1 1 OR 2 1 OR 2	36 61 86 86	60 70 100 100	6 4 2 2	10 8 6 6	- 36 36 36	- 25 50 50	- 50 50 50	- 25 50 50	- 8 8 8	- 10 8 8	- 10 10 10	- 10 10 10
QH481-B0Z -B05 -B10 ⑤ -B15	230/208-3	1 1 1 1	26 45 53 53	40 50 60 60	8 8 6 6	10 10 10 10	- - - -	- - - -	- - - -	- - - -	- - - -	- - - -	- - - -	- - - -
QH481-C0Z -C06 -C09 ⑤ -C15	460-3	1 1 1 1	16 26 30 30	20 30 30 30	12 10 10 10	12 10 10 10	- - - -	- - - -	- - - -	- - - -	- - - -	- - - -	- - - -	- - - -

- ① Maximum size of the time delay fuse or HACR type circuit breaker for protection of field wiring conductors.
- ② Based on 75° C copper wire. All wiring must conform to the National Electrical Code and all local codes.
- ③ These "Minimum Circuit Ampacity" values are to be used for sizing the field power conductors. Refer to the National Electric Code (latest revision), article 310 for power conductor sizing. CAUTION: When more than one field power conductor circuit is run through one conduit, the conductors must be derated. Pay special attention to Note 8 of Table 310 regarding Ampacity Adjustment Factors when more than three conductors are in a raceway.
- ④ Maximum KW that can operate with heat pump on is 10KW. Other 5KW energizes during emergency heating only.
- ⑤ Maximum KW that can operate with heat pump on is 9KW. Other 6KW energizes during emergency heating only.

FIGURE 1 - UNIT DIMENSIONS

DIMENSION CHART					
UNIT	DIM. A	DIM. B	DIM. C	DIM. D	DIM. E
QH241					
QH301	7.625	42.000	30.000	30.000	43.000
QH361					
QH421					
QH481	10.625	48.000	36.000	36.000	49.000

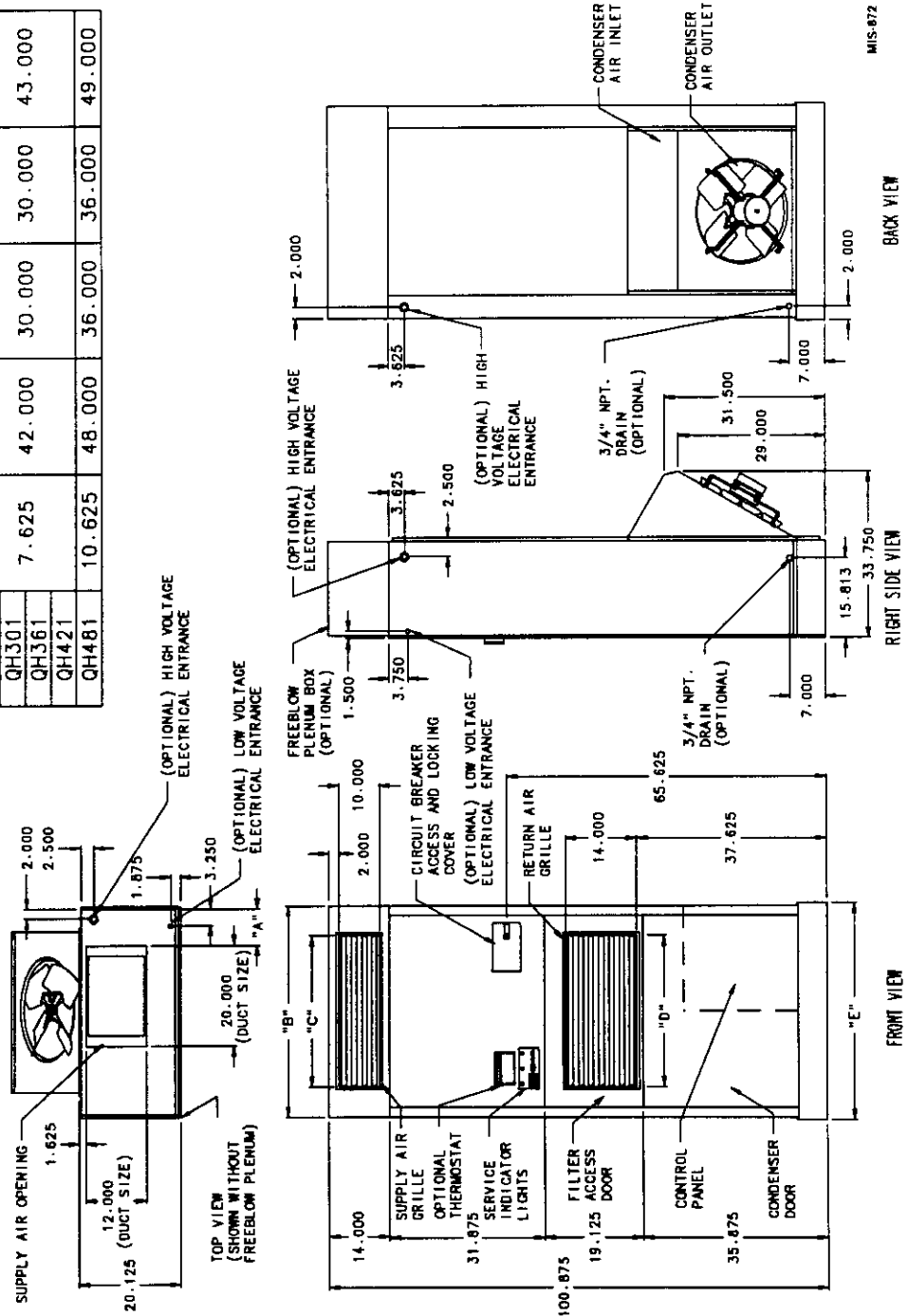

MIS-872

SHIPPING DAMAGE

Upon receipt of equipment, the carton should be checked for external signs of shipping damage. The skid must remain attached to the unit until the unit is ready for installation. If damage is found, the receiving party must contact the last carrier immediately, preferably in writing, requesting inspection by the carrier's agent.

UNIT REMOVAL FROM SKID

WARNING

This unit is heavy and requires more than one person to handle and remove from the skid. Check unit wheels to ensure that wheels are locked before removing from skid. Extreme caution must be taken to prevent injury to personnel and damage to the unit.

It is recommended that the unit not be removed from the skid with a fork lift since the air seal under the unit could be damaged. See Figure 2.

The shipping brackets on each side of the unit must be removed and discarded. See Figure 3-A. The return air grille panel can be removed to provide a place to hold the unit. The unit can be slid forward on the skid until the front

FIGURE 2

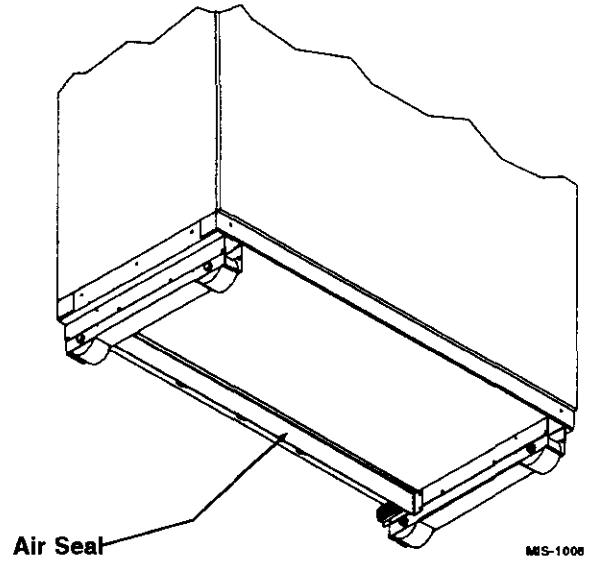

wheels hang over the edge of the skid. See Figure 3-B. The unit can be tipped forward and slid down the edge of the skid until the front wheels touch the ground. See Figure 3-C. The wheels will not roll. They are shipped from the factory locked so they will not roll. The back of the skid will have to be held down to keep it from tipping up. The skid can be slid out from under the unit. The unit can then be set upright.

FIGURE 3

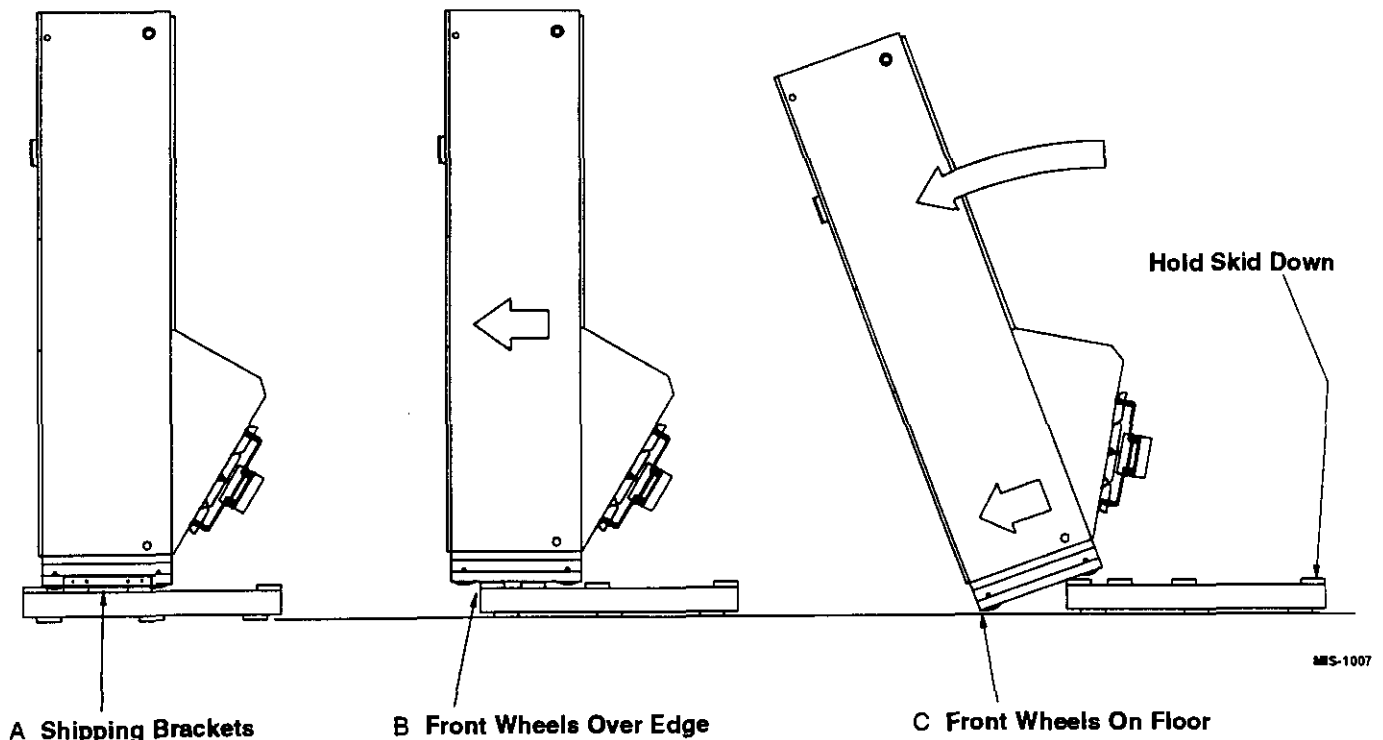

HANDLING UNIT AFTER REMOVAL FROM SKID

⚠ WARNING

Exercise extreme caution when pushing the unit on the rollers. Handle and push from the lower 1/3 of the unit. Insure that debris is not on the floor where the unit is to be moved on the rollers. Failure to do so could result in the unit tipping over and causing bodily injury and/or damage to the unit.

The unit will have to be turned sideways and removed from the skid to fit through a 36" doorway. If the door height allows, the unit can be slid sideways through the door.

If the unit can not be slid through the door, then the unit will have to be put on a cart and tipped down to roll through the door. It is recommended that an appliance cart by used with a strap to hold the unit on the cart. The wheels of the unit *must be locked*. If the wheels were allowed to roll, the unit could roll off the cart. *The unit should always be carted from the left side.* This is the side where the compressor is located. See Figure 4. The blade of the appliance cart should be slid under the wheels of the unit. The strap of the appliance cart should be placed around the unit and strapped tightly. Help will be required to tip the unit back onto the cart. The unit can be leaned far enough back to be rolled through the door. Be careful when setting the unit back up to keep from damaging the unit.

FIGURE 4

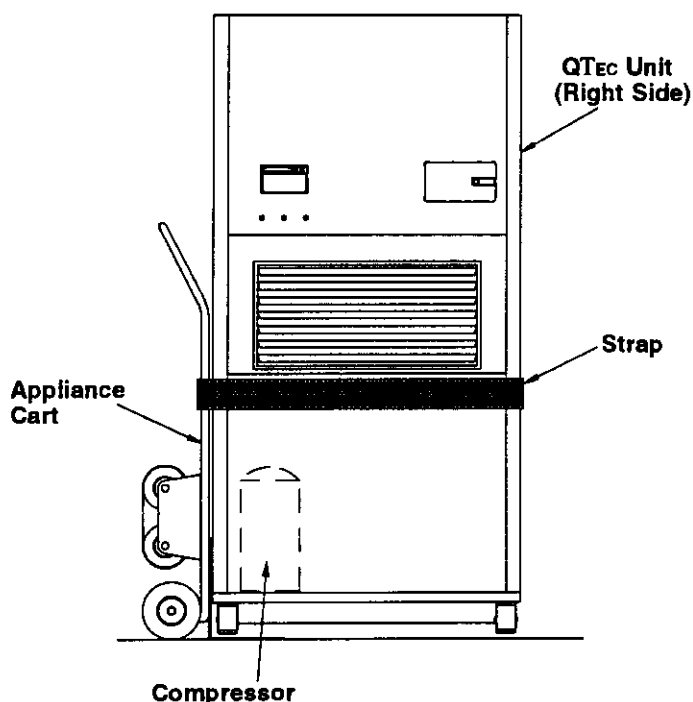

MIS-1006

GENERAL

The equipment covered in this manual is to be installed by trained, experienced service and installation technicians.

The unit is designed for use with or without duct work. For use without duct work, Plenum Box QPB** is recommended.

These instructions explain the recommended method to install the air cooled self-contained unit and the electrical wiring connections to the unit.

These instructions and any instructions packaged with any separate equipment required to make up the entire air conditioning system should be carefully read before beginning the installation. Note particularly "Start Procedure" and any tags and/or labels attached to the equipment.

While these instructions are intended as a general recommended guide, they do not supersede any national and/or local codes in any way. Authorities having jurisdiction should be consulted before the installation is made. See Page 1 for information on codes and standards.

Size of unit for a proposed installation should be based on heat loss calculation made according to methods of Air Conditioning Contractors of America (ACCA). The air duct should be installed in accordance with the Standards of the National Fire Protection Systems of Other Than Residence Type, NFPA No. 90A, and Residence Type Warm Air Heating and Air Conditioning Systems, NFPA No. 90B. Where local regulations are at a variance with instructions, installer should adhere to local codes.

MINIMUM INSTALLATION HEIGHT

The minimum installation height of the unit with a Free Blow Plenum is 8 ft. 6 in. This provides enough clearance for the plenum to be removed. See Figure 5.

The minimum installation height for ducted applications is 8 ft. 4-1/2 in. This provides enough clearance to install the duct work. See Figure 6.

FIGURE 5 - INSTALLATION WITH FREE BLOW PLENUM

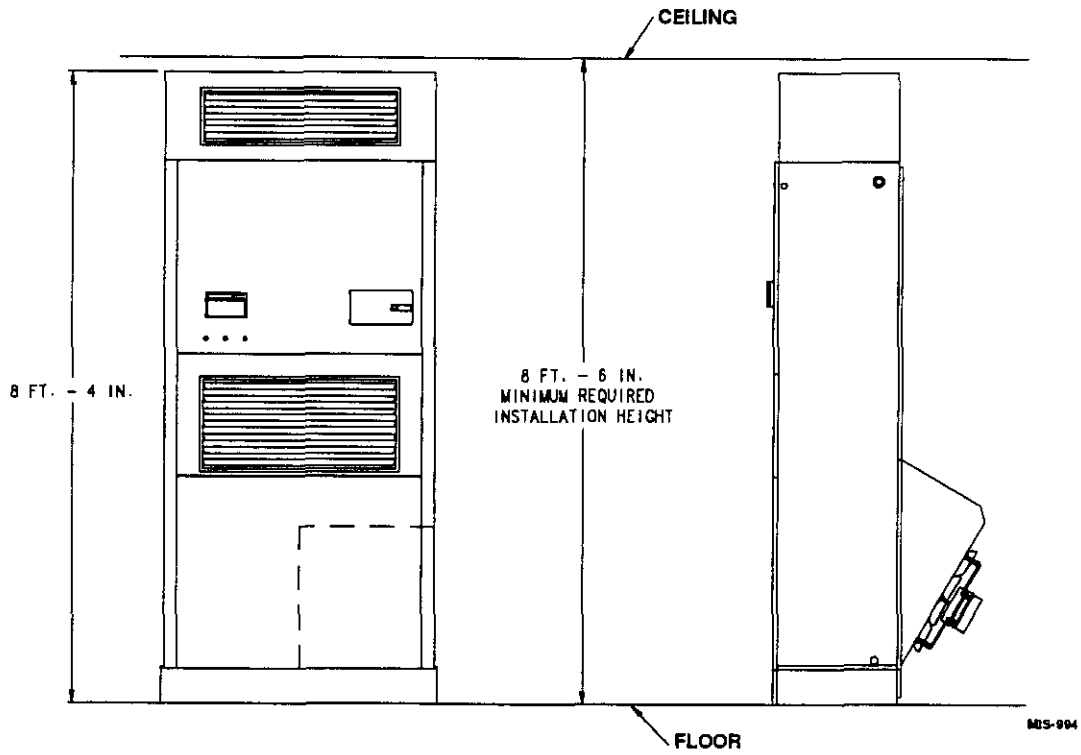
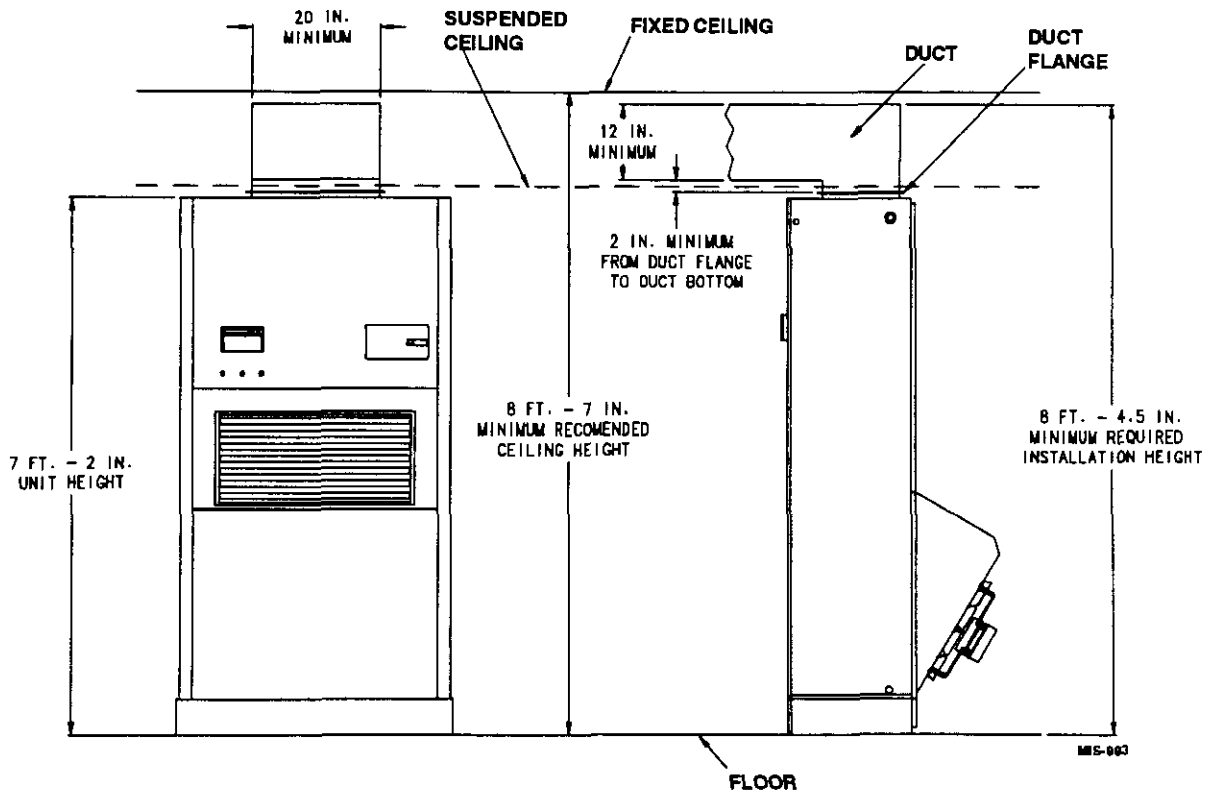

FIGURE 6 - DUCTED APPLICATION



DUCT WORK

Any heat pump is more critical of proper operating charge and an adequate duct system than a straight air conditioning unit. All duct work must be properly sized for the design air flow requirement of the equipment. Air Conditioning Contractors of America (ACCA) is an excellent guide to proper sizing. All duct work or portions thereof not in the conditioned space should be properly insulated in order to both conserve energy and prevent condensation or moisture damage. When duct runs through unheated spaces, it should be insulated with a minimum of one inch of insulation. Use insulation with a vapor barrier on the outside of the insulation. Flexible joints should be used to connect the duct work to the equipment in order to keep the noise transmission to a minimum.

The QTEC series heat pump has provision to attach a supply air duct to the top of the unit. Duct connection size is 12 inches x 20 inches. The duct work is field supplied and must be attached in a manner to allow for ease of removal when it becomes necessary to slide the unit out from the wall for service. See Figure 7 for suggested attachment method.

NOTE: Unit cabinet, supply air duct and free blow plenum are approved for "0" clearance to combustible material.

FIGURE 7 – SUPPLY DUCT CONNECTIONS

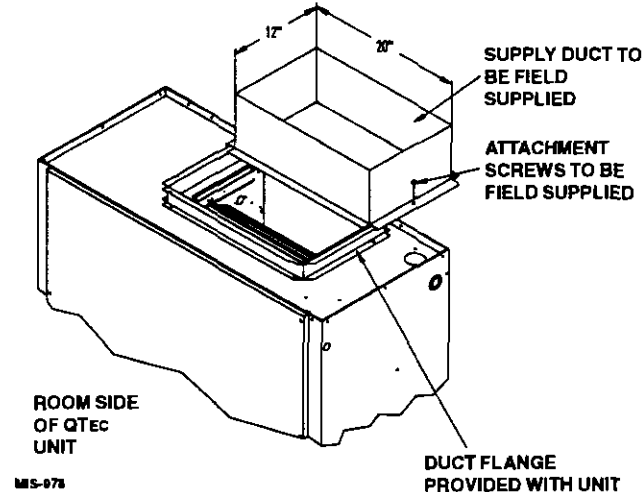

The QTEC series heat pumps are designed for use with free return (non-ducted) and either free blow with the use of QPB Plenum Box or a duct supply air system.

The QPB Plenum Box mounts on top of the unit and has both vertically and horizontally adjustable louvers on the front discharge grille. See Optional Accessories, Page 25, for the correct Plenum Box model number.

When used with a ducted supply, a QCX Cabinet Extension can be used to conceal the duct work above the unit to the ceiling. This extends 20" above the unit for a total height above the floor of 10'-7/8". See Optional Accessories, Page

25, for the correct Cabinet Extension model number. The unit is equipped with a variable speed indoor blower motor which increases in speed with an increase in duct static pressure. The unit will therefore deliver proper rated air flow up to the Maximum ESP shown in Table 9. However, for quiet operation of the air system, the duct static should be kept as low as practical, within the guidelines of good duct design.

FILTERS

Two 1 inch throw away filters are supplied with each unit. An indicator light on the front exterior panel of the unit will be lit when the filters require service. The filters fit into a rack that slides into position. Refer to Figure 8.

The filters are serviced from the inside of the building by removing the return air grille panel. This panel is attached by four (4) 1/4 turn fasteners. The return air grille panel is equipped with a door switch that will shut the unit down while the filters are being serviced.

Once the filters are replaced, the dirty filter sensor must be reset to turn the indicator light off. The sensor is located on the right side of the unit just below the filter rack. See Figure 8. The knob on the front of the sensor should be turned clockwise to reset the sensor.

The internal filter brackets are adjustable to accommodate 2 inch filters. The tabs for the 1 inch filters must be bent down to allow the 2 inch filters to slide in place.

FIGURE 8 – FILTER LOCATION

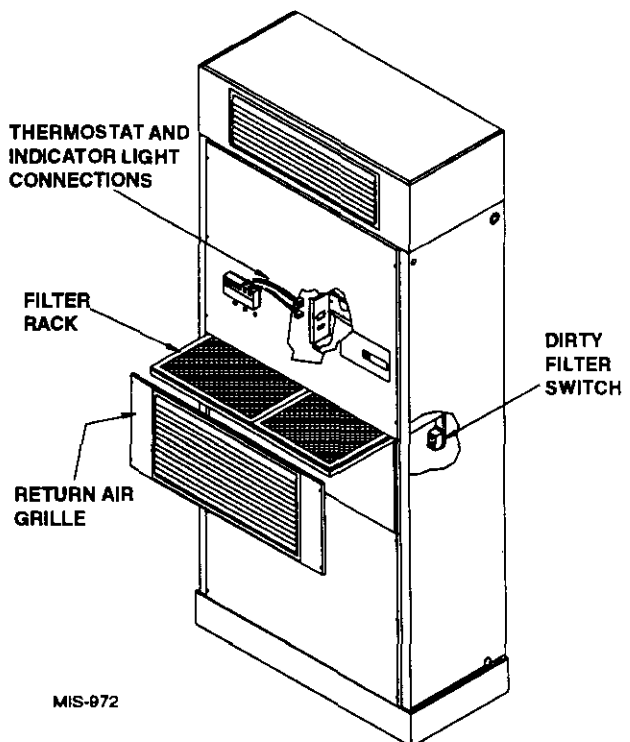

DIRTY FILTER SWITCH ADJUSTMENT

The dirty filter switch is located on the right side of the unit below the filter rack. The dirty filter switch alerts the user to a dirty filter by turning on the light in the front panel of the unit.

The dirty filter switch can be adjusted by turning the screw on the front of the switch. This must be done with the blower running and the filters in place. The desired restriction should be placed on the filters. This can be done by placing pieces of paper on the filters until the appropriate amount of the filters are covered. The recommended restriction is 75%. If the dirty filter flag appears in the window of the filter switch, turn the screw one turn clockwise and reset the filter switch. This should be repeated until the dirty filter flag does not appear in the filter switch window after it has been reset. Slowly turn the screw counterclockwise until the dirty filter flag appears in the filter switch window. Be sure to remove the restriction before putting the unit back into service.

FRESH AIR INTAKE

The fresh air damper assembly is standard equipment with the unit because of the variety of state or local codes requiring fresh air capability. It is shipped already attached to each unit.

All capacity, efficiency and cost of operation information as required for Department of Energy "Energyguide" Fact Sheets is based upon the fresh air blank-off plate in place and is recommended for maximum energy efficiency.

The blank-off plate is available upon request from the factory and is installed in place of the fresh air damper shipped with each unit.

On all 208/230 volt models, when G circuit is de-energized the indoor blower motor will continue to run for one minute.

For details on energy recovery ventilation see separate section.

CONDENSATE DRAIN

There are two drain connections on the unit. The side drain is located on the bottom right side of the unit. The rear drain is an optional drain, and is located on the right lower rear panel of the unit. The rear drain is shipped with a plug installed.

The *side drain* requires a water trap for proper drainage. See Figure 9. The drain can be routed through the floor or through the wall. *If the drain is to be routed through an unconditioned space, it must be protected from freezing.* The drain line must be able to be removed from the unit if it is necessary to remove the unit from the wall.

FIGURE 9 – SIDE DRAIN (SIDE VIEW)

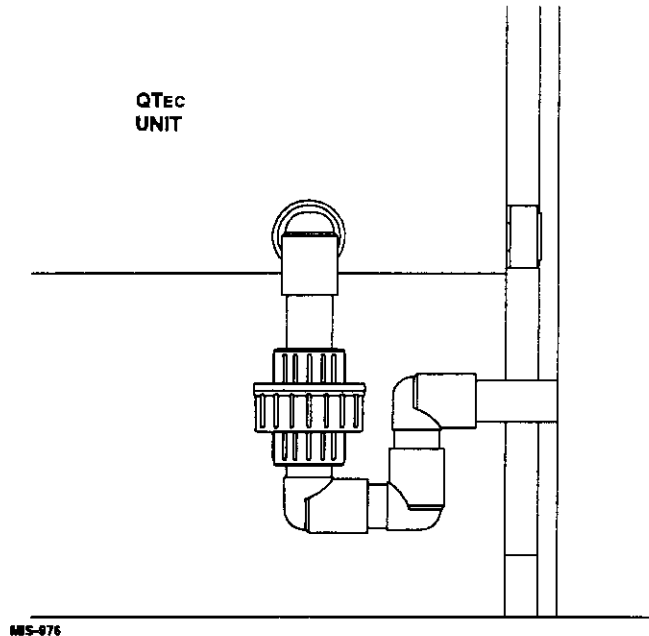

The *rear drain* can be used with wall thickness of up to 10 inches where a water trap can be installed between the unit and the interior wall. See Figure 10. The trap cannot extend beyond the edge of the unit or it will interfere with the wall mounting bracket. When the rear drain is used, the plug must be removed and installed in the side drain. The drain can be routed through the floor or through the wall. If the drain is routed through the wall, the drain line must be positioned such that it will not interfere with the sleeve flange or the grille. See Figure 11. *If the drain is to be routed through an unconditioned space, it must be protected from freezing.*

FIGURE 10 – OPTIONAL REAR DRAIN

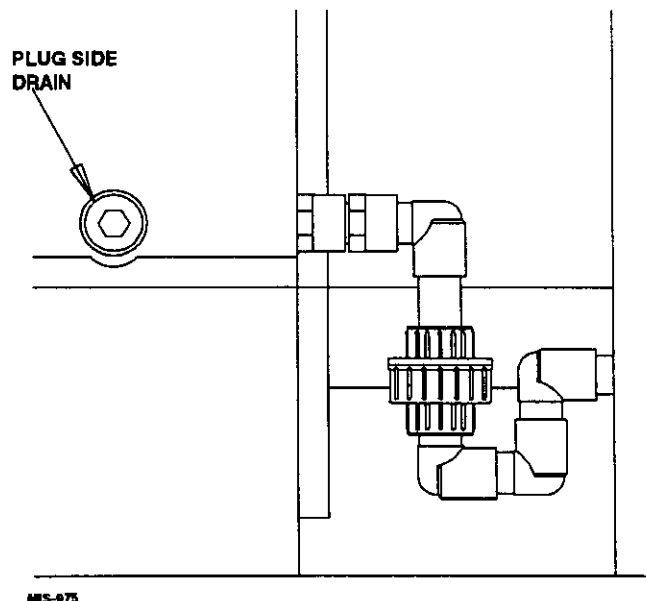
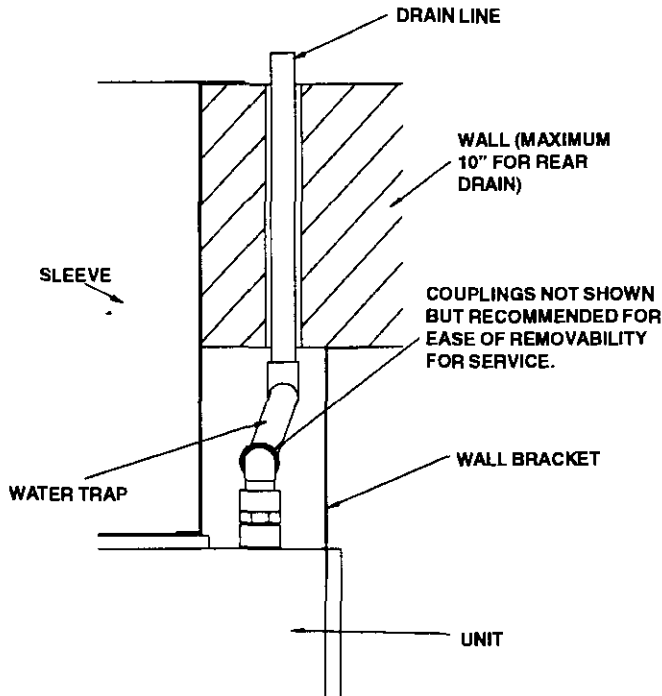

FIGURE 11 – REAR DRAIN (TOP VIEW)



MIS-977

SERVICE LIGHTS

The unit is equipped with three service lights which signal the user that service is required. These lights are labeled Service Condensate Drain, Service Filter, and Service Unit.

The *Service Condensate* light indicates that there is water in the secondary drain pan and that the primary drain must be checked. This also shuts the unit off so that no additional water will be added which would cause the drain pan to overflow.

The *Service Filter* light indicates that the filters need to be changed. See the Filter section of this manual for service procedure.

The *Service Unit* light indicates that the unit has been shut off by a refrigerant control device. This indicates that the unit needs to be serviced.

FIGURE 12 – UNIT MOUNTING
(Refer to Installation Instructions, Page 12)

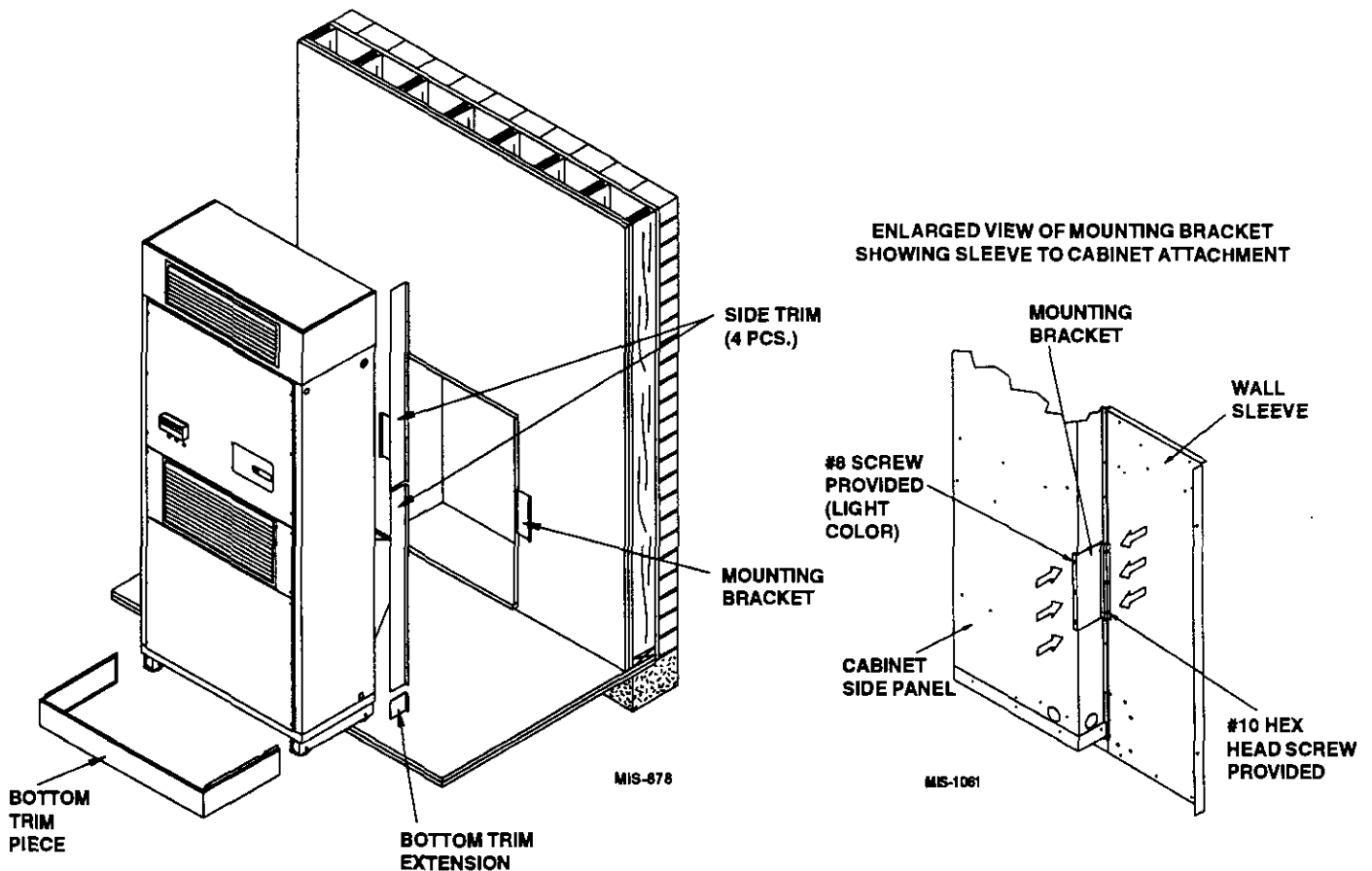

MIS-878

MIS-1061

Installation Instructions

MOUNTING THE UNIT

When installing a QTEC unit near an interior wall on the left side, a minimum of 8 inches is required; 12 inches is preferred.

When installing a QTEC unit near an interior wall on the right side, a minimum of 12 inches is required as additional space is required to connect the side drain. If the rear condensate drain kit QCDS48 is used the minimum can be reduced to 8 inches.

This clearance is required to allow for the attachment of the unit to the sleeve and side trim pieces to the wall.

This unit is to be secured to the wall sleeve with mounting brackets provided. The unit itself, the supply duct, and the free blow plenum are suitable of "0" clearance to combustible material.

Following are the steps for mounting the QTEC, for reference see Figure 12 (page 11).

1. Attach mounting brackets to the wall sleeve with screws provided.
2. Position the unit in front of the sleeve with the condenser section toward the sleeve.

3. Remove the locking screws from the wheels. Refer to Figure 13.
4. Roll the unit into the sleeve. Make sure to check both sides of the units as it is being rolled to keep it centered in the sleeve. Also check the alignment to the mounting brackets.
5. Make sure the gasket on the rear of the unit is touching the sleeve across the top and down both sides. This is a rain water seal.
6. Secure the mounting brackets to the unit with screws provided, #10 hex head sheet metal screws.
7. Bottom trim extensions are provided for use when wall is less than 14 inches but greater than 12 inches. Secure to wall with screws (not provided).
8. Attach the bottom trim piece to the unit with the screws provided (dark colored).
9. Position side trim pieces to the wall and attach with field supplied screws. The side trim is supplied in four pieces. The top pieces may be cut off to suit your height requirements.

NOTE: If the exterior wall thickness is less than 12 inches, a side trim extension piece kit, model QSTX42, is available.

FIGURE 13

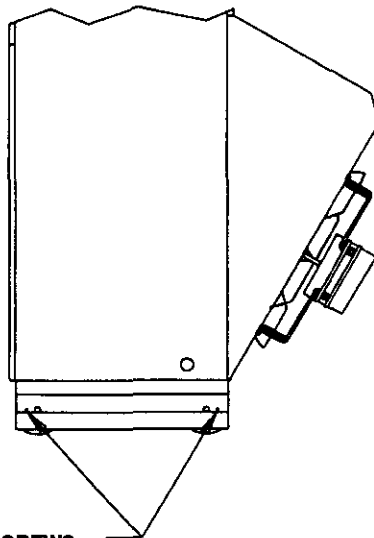

**REMOVE SCREWS
FROM WHEELS
BEFORE ROLLING
INTO PLACE**

MIS-1018

WIRING – MAIN POWER

Refer to the unit rating plate and/or Table 2 for wire sizing information and maximum fuse or “HACR Type” circuit breaker size. Each unit is marked with a “Minimum Circuit Ampacity”. This means that the field wiring used must be sized to carry that amount of current. Depending on the installed KW of electric heat, there may be two field power circuits required. If this is the case, the unit serial plate will so indicate. All models are suitable only for connection with copper wire. Each unit and/or wiring diagram will be marked “Use Copper Conductors Only”. These instructions **MUST BE** adhered to. Refer to the National Electrical Code (NEC) for complete current carrying capacity data on the various insulation grades of wiring material. All wiring must conform to NEC and all local codes.

The electrical data lists fuse and wire sizes (75° C copper) for all models, including the most commonly used heater sizes. Also shown are the number of field power circuits required for the various models with heaters.

The unit rating plate lists a “Maximum Time Delay Relay Fuse” or “HACR Type” circuit breaker that is to be used with the equipment. The correct size must be used for proper circuit protection, and also to assure that there will be no nuisance tripping due to the momentary high starting current of the compressor motor.

The disconnect access door on this unit may be locked to prevent unauthorized access to the disconnect.

See Start Up section for information on three phase scroll compressor start-ups.

The field wiring connections are located behind the top panel in the circuit breaker panel. The return air panel must be removed first. This panel is equipped with a door switch which shuts the unit down when it is removed. The filter rack must be removed next. *The connections for the thermostat and the indicator lights must be disconnected before the top panel can be removed.* See Figure 14. The connections are located behind the top panel.

The top panel should remain fastened to the unit until the connectors have been disconnected, or damage to the connectors may occur. The locking tabs on either side of the connectors must be released. The connector can be pulled straight out of the socket. Once all the connectors have been removed, the top panel can be removed.

WIRING – LOW VOLTAGE WIRING

230/208V, 1 PHASE AND 3 PHASE EQUIPMENT DUAL PRIMARY VOLTAGE TRANSFORMERS

All equipment leaves the factory wired on 240V tap. For 208V operation, reconnect from 240V to 208V tap. The acceptable operating voltage range for the 240 and 208V taps are as noted in Table 3.

TABLE 3 – OPERATING VOLTAGE RANGE

TAP	RANGE
240V	253 - 216
208V	220 - 187

NOTE: The voltage should be measured at the field power connection point in the unit and while the unit is operating at full load (maximum amperage operating condition).

FIGURE 14 – COMPONENT LOCATION

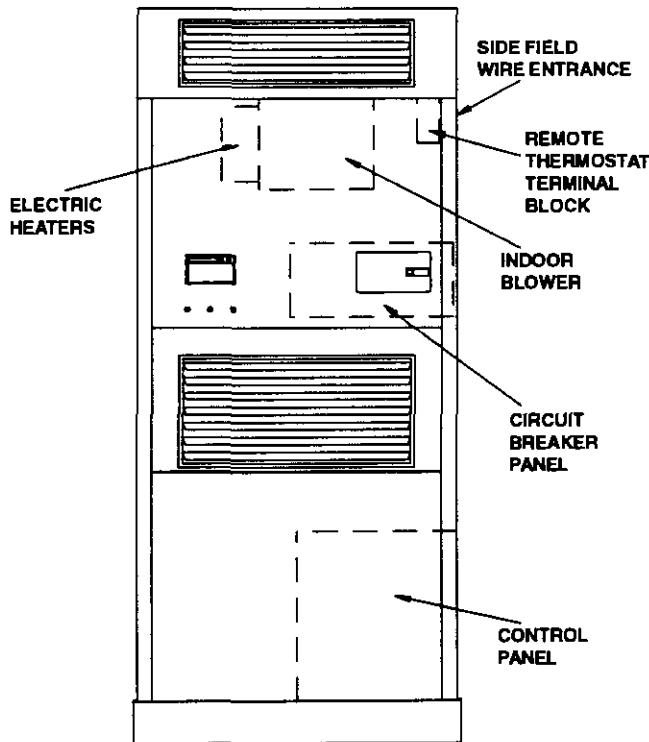

MIS-982

The standard climate control option is a remote thermostat connection terminal block. See Figure 15 for wiring diagram. Compatible thermostats are listed in Table 4.

The Climate Control **Option A** is an electronic, non-programmable manual change over thermostat. The sub base of the thermostat is factory wired to the front panel of the unit. Compatible for use with Bard CS2000 Controller and Energy Recovery Ventilator.

The Climate Control **Option B** is an electronic, non-programmable manual change over thermostat and a four (4) hour timer. The sub base of the thermostat and the timer are factory wired to the front panel of the unit. Compatible for use with Energy Recovery Ventilator.

The Climate Control **Option C** is an electronic, non-programmable manual change over thermostat and six (6) hour timer. The sub base of the thermostat and the timer are factory wired to the front panel of the unit. Compatible for use with Energy Recovery Ventilator.

The Climate Control **Option D** is an electronic, programmable thermostat. The sub base of the thermostat is factory wired to the front panel of the unit. Compatible for use with Energy Recovery Ventilator or Economizer.

FIGURE 15 - THERMOSTAT PLUG TERMINALS

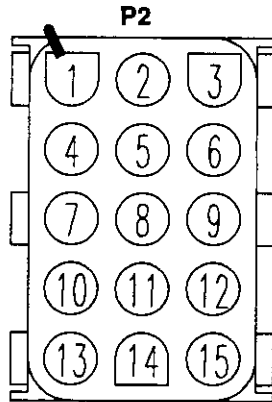
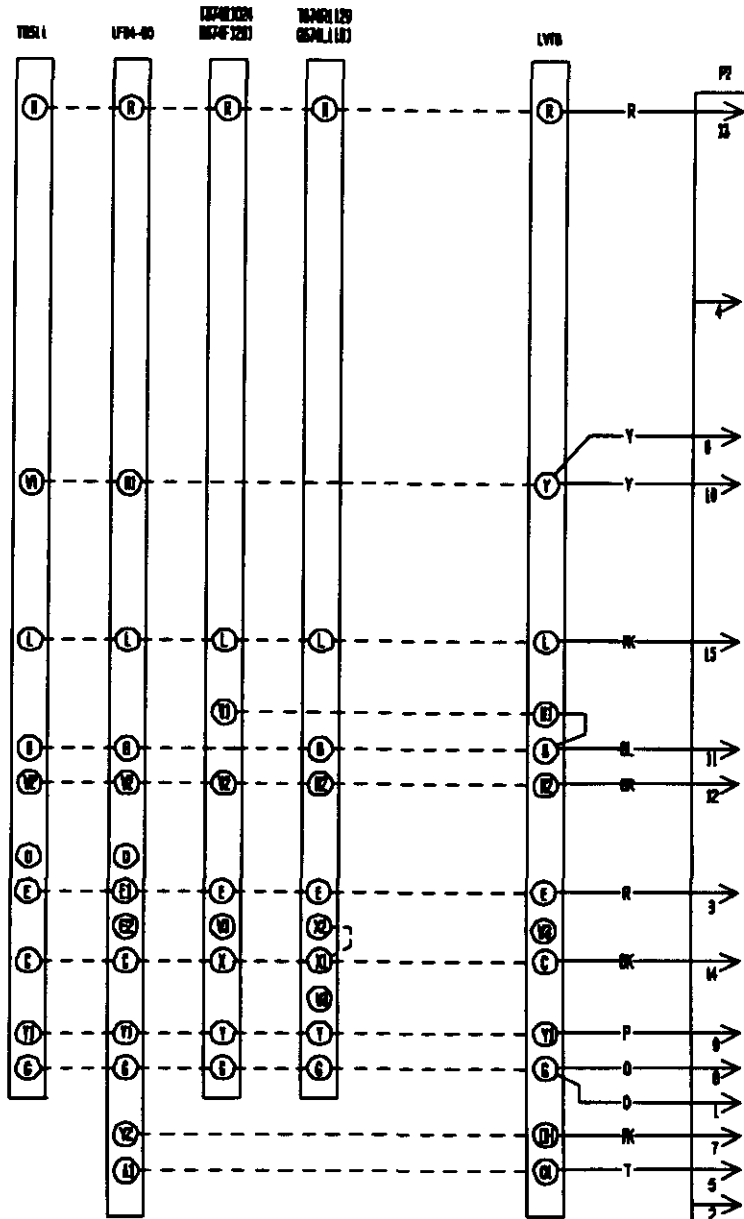

TABLE 4 - WALL THERMOSTATS AND SUBBASE COMBINATIONS

Thermostat	Subbase	Predominant Features
8407-017 (T874R1129)	8404-009 (Q674L1181)	Heat or Cool (1) No Auto
8403-018 (T874N2024)	8404-010 (Q6741261)	Automatic Heat/Cool (2) Changeover Position
8403-034 (1F94-80)	N/A	Manual/Auto/Heat/Cool (2) Programmable Electronic
8403-037 (1F59-1)	N/A	Manual Heat/Cool Electronic

FIGURE 16 - REMOTE THERMOSTAT WIRING DIAGRAM



MIS-1284

FIGURE 17

Handwritten note: 11-23-11

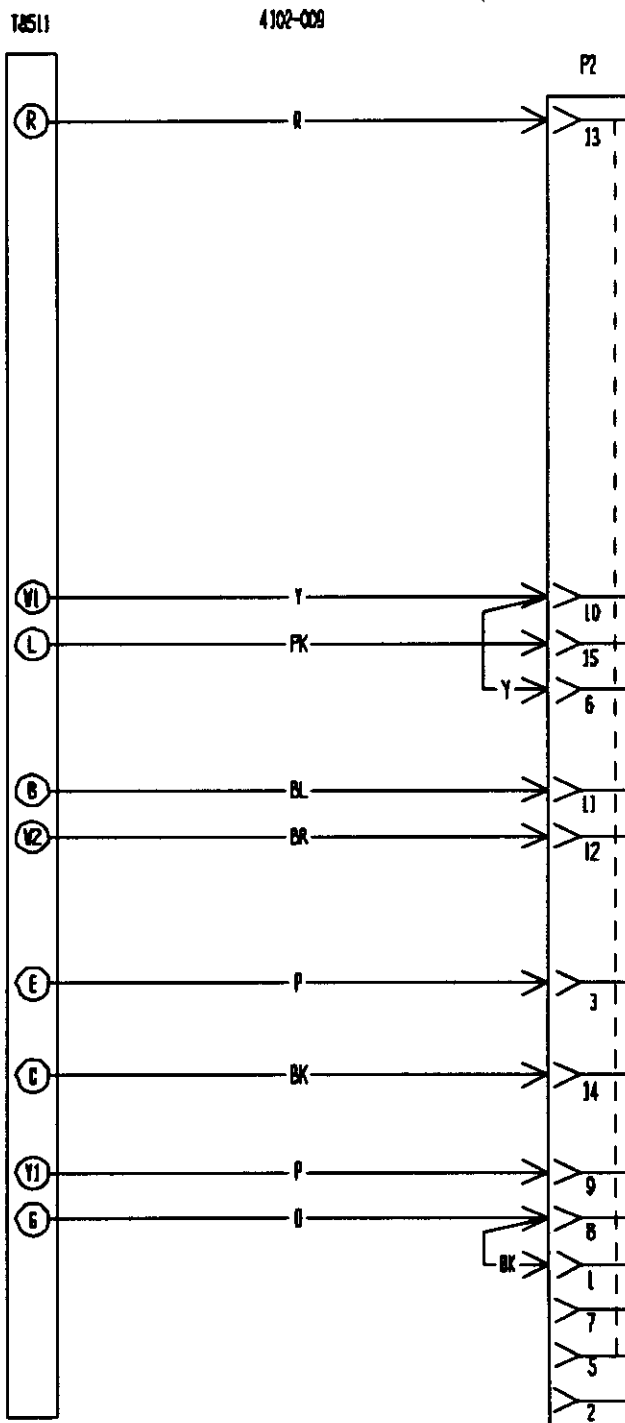

4102-009

293 - Control

FIGURE 18

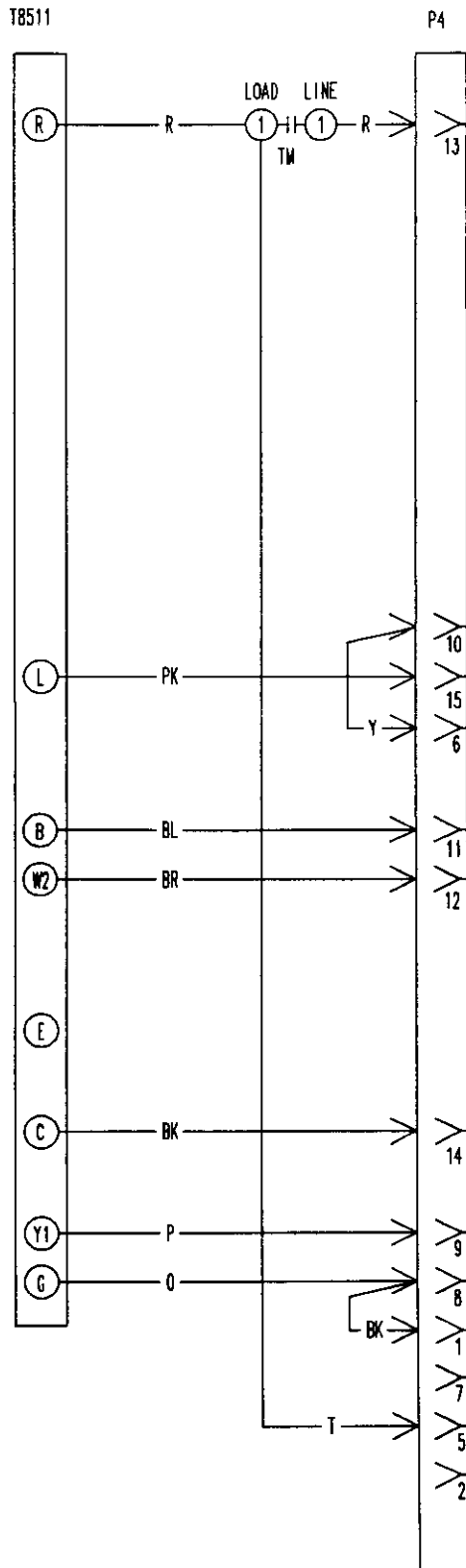

4102-010

D-300-531

FIGURE 19

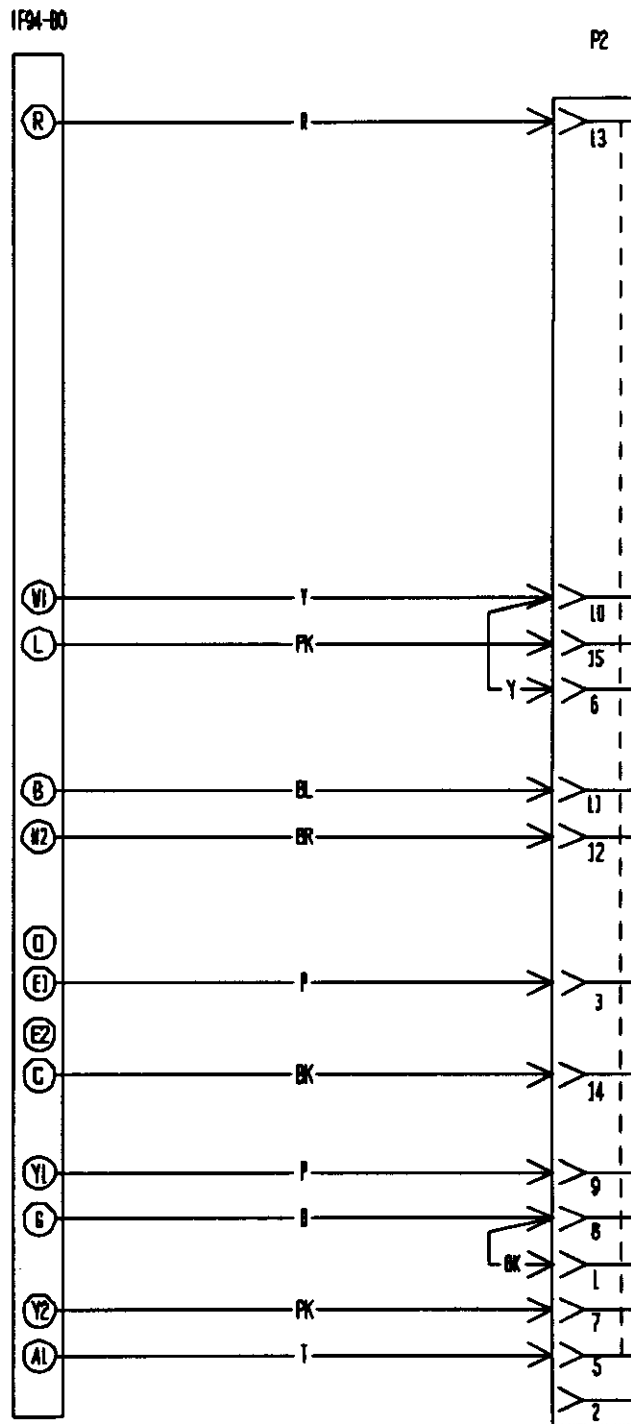

4102-004

Start Up

DESCRIPTION OF STANDARD EQUIPMENT

Solid State Electronic Heat Pump Control

Provides efficient 30 minute defrost cycle. A thermistor sensor and speed up terminal for service along with a 10 minute defrost override are standard on the electronic heat pump control.

High / Low Pressure Switch

Provides refrigerant circuit high pressure and loss of charge protection. Includes lockout circuit that is re-settable from room thermostat.

Five Minute Compressor Time Delay

Provides short cycle protection for the compressor which extends compressor life. Built into the electronic heat pump control as standard.

Service Lights

3 service lights indicate when service is required.

- System Service – detects high or low pressure switch operation for compressor protection.
- Filter Service – detects a dirty filter condition.
- Drain Service – detects a clogged drain by detecting water in the secondary drain system. Shuts system down until corrective action is taken.

Two Speed Outdoor Motor

Has two speeds and is controlled by an outdoor thermostat.

Interlock Door Switch

When the service door is removed, automatically shuts the unit down.

OPTIONAL CFM (QH361, QH421 AND QH481 ONLY)

These units are shipped from the factory set to operate at the optional CFM level shown in Table 9. This provides lower operating sound levels for non-ducted, free discharge applications. This CFM level will reduce the system capacity performance by approximately 2% at the same energy efficiency.

Rated CFM is required for ducted applications for maximum performance rating. To obtain full CFM on these models, connect jumper wire as follows:

1. Disconnect all power to the unit. Failure to do so may result in damage to the motor.
2. Remove return air access panel.
3. Remove filter rack.
4. Unplug service lights and thermostat options. (See Figure 3.)
5. Remove upper door.
6. Remove inner control panel cover.
7. Add pink jumper wire (provided) to terminal 5 and 6 on the terminal board.
8. Reverse steps to reassemble.

IMPORTANT INSTALLER NOTE

For improved start-up performance, wash the indoor coil with a dishwashing detergent.

THREE PHASE SCROLL COMPRESSOR START UP INFORMATION

Scroll compressors, like several other types of compressors, will only compress in one rotational direction. Direction of rotation is not an issue with single phase compressors since they will always start and run in the proper direction.

However, three phase compressors will rotate in either direction depending upon phasing of the power. Since there is a 50-50 chance of connecting power in such a way as to cause rotation in the reverse direction, verification of proper rotation must be made. Verification of proper rotation direction is made by observing that suction pressure drops and discharge pressure rises when the compressor is energized. Reverse rotation also results in an elevated sound level over that with correct rotation, as well as, substantially reduced current draw compared to tabulated values.

Verification of proper rotation must be made at the time the equipment is put into service. If improper rotation is corrected at this time there will be no negative impact on the durability of the compressor. However, reverse operation for over one hour may have a negative impact on the bearing due to oil pump out.

NOTE: If compressor is allowed to run in reverse rotation for several minutes the compressor's internal protector will trip.

All three phase scroll compressors used in the QTEC series are wired identically internally. As a result, once the correct phasing is determined for a specific system or installation, connecting properly phased power leads to the same Fusite terminal should maintain proper rotation direction. The direction of rotation of the motor may be changed by reversing any two line connections to the unit.

SERVICE HINTS

1. Caution user to maintain clean air filters at all times. Also, not to needlessly close off supply air registers. This may reduce air flow through the system which shortens equipment service life as well as increasing operating costs and noise levels.
2. Switching to heating cycle at 75°F or higher outside temperature may cause a nuisance trip of the remote reset high pressure switch. Turn thermostat off, then on to reset the high pressure switch.
3. The heat pump wall thermostats perform multiple functions. Be sure that all function switches are correctly set for the desired operating mode before trying to diagnose any reported service problems.

4. Check all power fuses or circuit breakers to be sure they are the correct rating.
5. Periodic cleaning of the outdoor coil to permit full and unrestricted airflow circulation is essential.
6. Some service requires the need to remove the unit from the wall including replacement of the indoor coil and/or the outdoor coil. Also servicing the outdoor fan motor or fan blade installed at a height that is not easily accessible from the outside of the building.

In order to remove the unit from the wall the following procedure must be used:

- a. Turn off power to the unit at the remote location. Some units may have more than one power supply.
- b. Disconnect field wiring at unit terminal block and remove from unit.
- c. Disconnect condensate drain.
- d. Remove the lower skirting around the unit.
- e. Remove wall mounting brackets from wall on each side of the unit.
- f. If unit is attached to duct work, remove upper cabinet extension by removing the top center screw only from the cabinet side panel.
- g. Remove screws that attach the duct work to the unit flanges.

This unit is equipped with four rollers mounted to the base. For ease of pulling unit out from the wall, you may want to remove the bottom service door which requires removal of the return air panel, and grip the front flange of the base pan then pull straight out.

7. Annual maintenance is required to make sure that all of the systems are functioning properly.
 - a. Check to make sure that the drains are not obstructed in any way.
 - b. Check the water level switch operation.
 - c. Remove any debris in the condenser section of the unit.
 - d. Inspect and clean mist eliminator as necessary.
 - e. Inspect and wash outdoor coil as necessary.

MIST ELIMINATOR SERVICE

A mist eliminator is supplied with the wall sleeve. The mist eliminator is constructed of an aluminum frame and mesh. The mist eliminator is located in the top section of the wall sleeve and can be removed from the inside of the building without removing the unit from the wall. This requires that the ventilation package must be removed.

It is recommended that the mist eliminator be inspected annually and serviced as required. The mist eliminator can be inspected from the outside of the building by looking through the outdoor grille. The mist eliminator can be

serviced from the outside by using a vacuum cleaner. The outdoor grille must be removed. Use the vacuum to remove dirt and debris from the surface of the mist eliminator. If additional cleaning is required, the mist eliminator will have to be removed from the sleeve.

The ventilation package will have to be removed to gain access to the mist eliminator. If the blank off plate option is used, it is not necessary to service the mist eliminator. The steps necessary to remove each of the vent options are listed below.

The mist eliminator can be cleaned by washing with soap and water. The excess water should be shaken off the mist eliminator before it is reinstalled.

BAROMETRIC FRESH AIR DAMPER (Standard)

Before starting, make sure the power has been turned off. The return air grille panel must be removed. The fresh air damper assembly can be seen on the back of the unit. (Refer to Figure 20.)

1. The fresh air damper is attached to the back of the unit with one screw on either side of the assembly. Both of the screws must be removed.
2. Once the mounting screws are removed, tilt the assembly down and lift it out.

The mist eliminator can be seen through the opening. The mist eliminator must be raised up and the bottom can be pulled toward the front of the unit.

ECONOMIZER (Option)

Before starting, make sure the power has been turned off. The return air grille panel must be removed. The economizer (ECON) can be seen after the panel has been removed.

1. The two mounting screws in the front of the ECON must be removed.
2. The power connectors for the ECON (located on the right side of the unit) must be disconnected. Squeeze the tabs on the sides of the connector and pull straight out. Unplug both of the connectors.
3. Slide the ECON straight out of the unit.

The mist eliminator can be seen through the opening in the back of the unit. The mist eliminator must be raised up and the bottom can be pulled toward the front of the unit and removed.

COMMERCIAL ROOM VENTILATOR (Option)

Before starting, make sure the power has been turned off. The return air grille panel must be removed. The commercial room ventilator (CRV) can be seen after the panel has been removed. The CRV must be removed to gain access to the mist eliminator.

1. The two mounting screws in the front of the CRV must be removed.

2. The power connectors for the CRV (located on the right side of the unit) must be disconnected. Squeeze the tabs on the sides of the connector and pull straight out. Unplug both of the connectors.
3. Slide the CRV straight out of the unit.

The mist eliminator can be seen through the opening in the back of the unit. The mist eliminator must be raised up and the bottom can be pulled toward the front of the unit and removed.

QTEC R ENERGY RECOVERY VENTILATOR (Option)

Before starting, make sure that the power has been turned off. The return air grille panel must be removed. The energy recovery ventilator (QERV) can be seen after the panel has been removed. To gain access to the mist eliminator, the QERV must be removed. (Refer to Figure 21.)

1. The front fill plate of the QERV must be removed. There is one screw on either side of the plate. Remove these screws and remove the plate.

**FIGURE 20
FRESH AIR DAMPER REMOVAL**

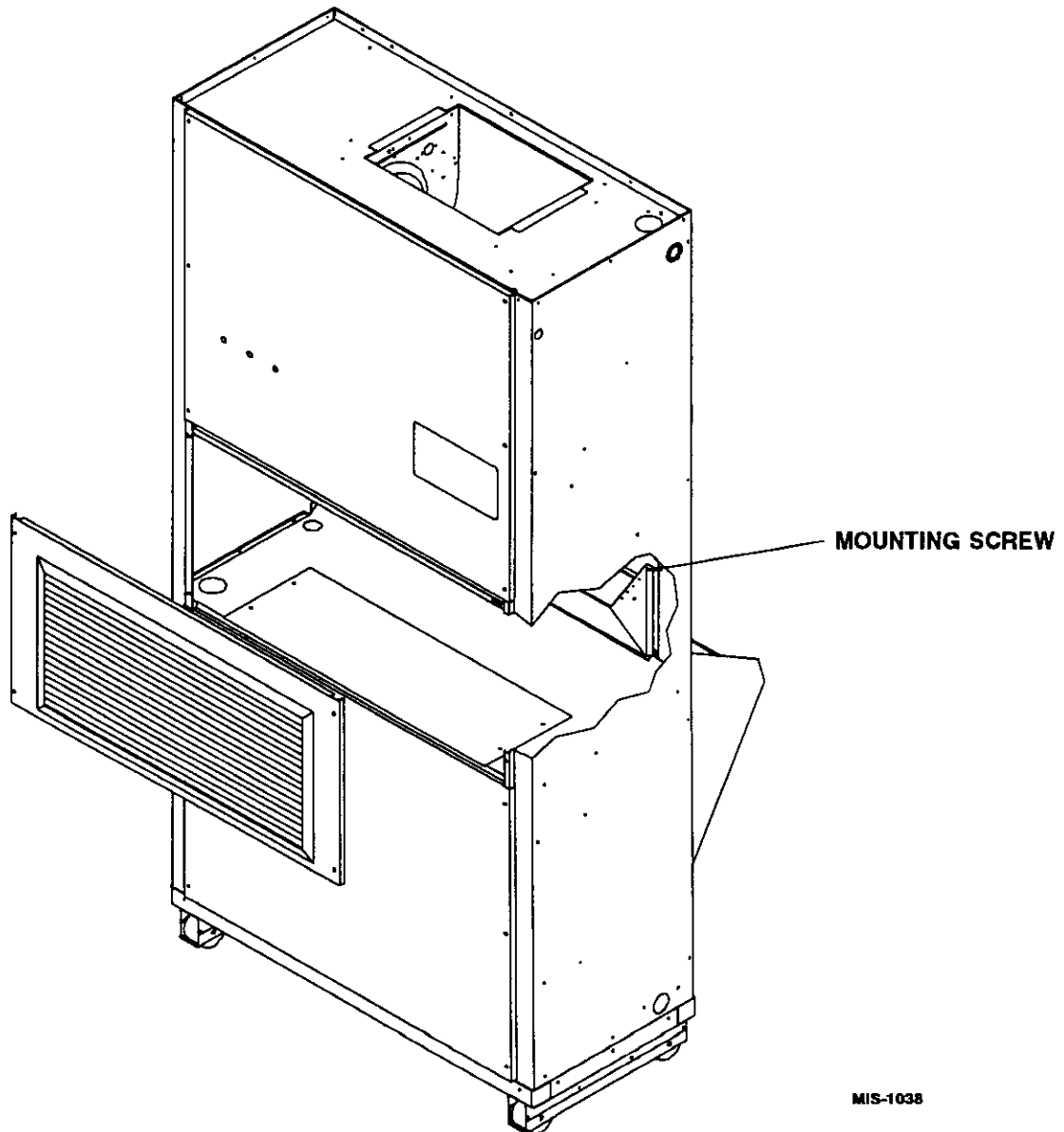

MIS-1038

2. On either side of the QERV there are mounting screws that hold the QERV in place. Remove both of these screws.
3. Underneath the heat recovery cassette there is a power connector for the lower blower assembly. To disconnect this plug, the tabs on both sides of the plug must be squeezed to release the plug. While squeezing the tabs, pull the plug out of the socket.

4. The QERV is plugged into the unit on the right side of the unit. Both of these plugs must be disconnected to remove the QERV. Squeeze the tabs on the sides of the connector and pull straight out.
5. Slide the QERV assembly straight out of the unit, being careful not to let the cassette slide out of the QERV.

The mist eliminator can be seen through the opening in the back of the unit. The mist eliminator must be raised up and the bottom can be pulled toward the front of the unit and removed.

**FIGURE 21
QERV REMOVAL**

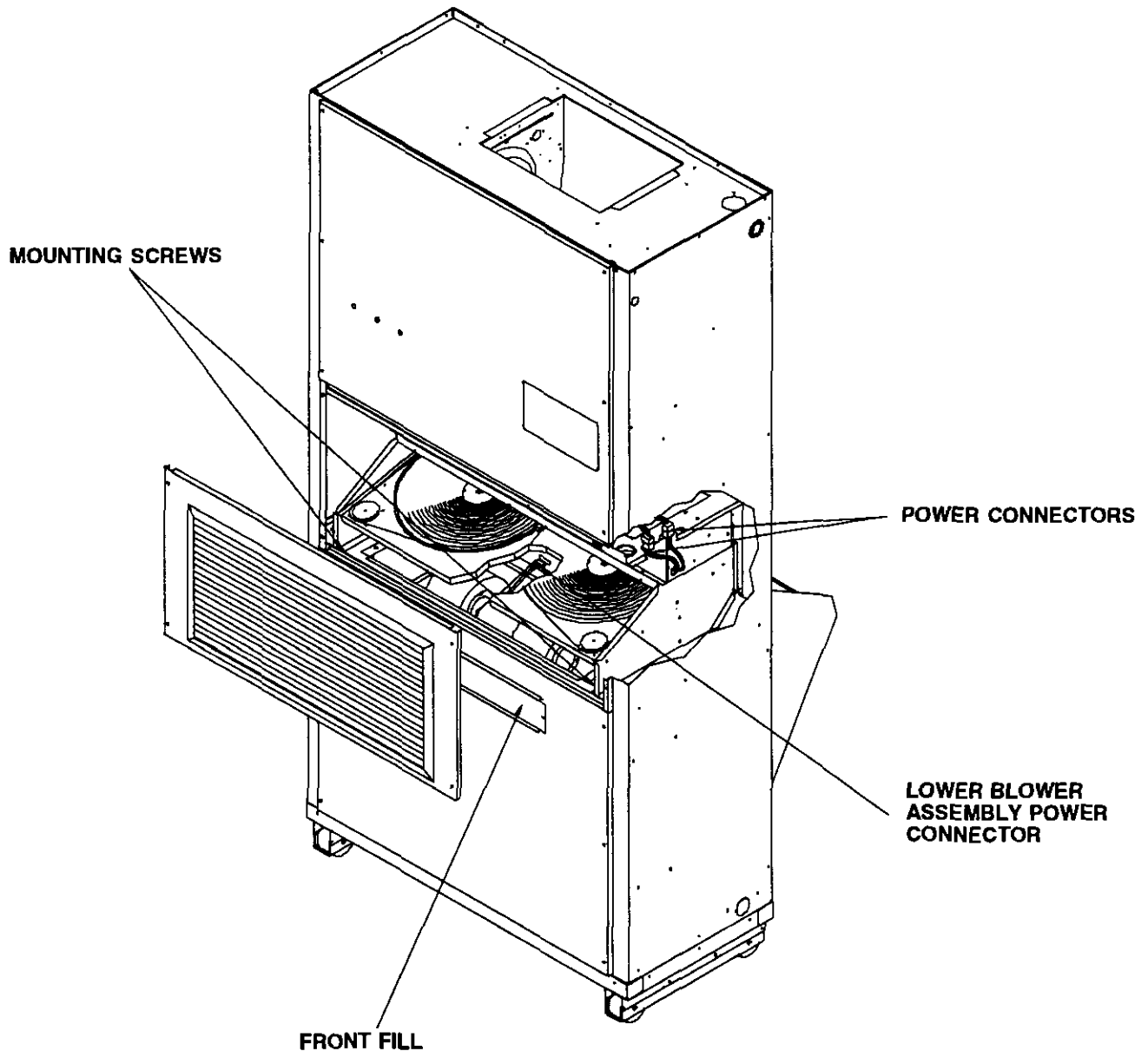

M18-1039

SEQUENCE OF OPERATION

Cooling – Circuit R-Y makes the thermostat pull in the compressor contactor starting the compressor and outdoor motor. The G (indoor motor) circuit is automatically completed on any call for cooling operation, or can be energized by manual fan switch on subbase for constant air circulation.

Heating – A 24V solenoid coil on reversing valve controls heating cycle operation. Two thermostat options, one allowing “Auto” change over from cycle to cycle and the other constantly energizing solenoid coil during heating season and thus eliminating pressure equalization noise except during defrost, are to be used. On “Auto” option, a circuit is completed for R-W1 and R-Y on each heating “on” cycle, energizing reversing valve solenoid and pulling in compressor contactor starting compressor and outdoor motor. R-G also makes starting indoor blower motor. Heat pump heating cycle now in operation.

The second option has no “Auto” change over position, but instead energizes the reversing valve solenoid constantly whenever the system switch on subbase is placed in “Heat” position, the “B” terminal being constantly energized from R. A thermostat demand for heat completes R-Y circuit, pulling in compressor contactor starting compressor and outdoor motor. R-G also make starting indoor blower motor.

High / Low Pressure Control provides protection for the compressor. In the event the system pressures go above 350 PSI or below 15 PSI in either cooling or heating mode the compressor will be stopped. This will activate the right hand red light marked “System Service” on the front of the unit. The lockout circuit will hold compressor off line. When the system problem is corrected, the unit operation can be restored by turning the main power supply off and then back on, or reset the room thermostat. The low pressure control has a bypass to eliminate nuisance lockout on cold start up.

Two Speed Outdoor Fan Motor There is a thermostat located in the main electrical box that controls the switching between high and low speed. When in cooling mode and the outdoor ambient temperature is above 80 degrees, the outdoor motor will run on high speed; below 80 degrees, it will run on low speed. In heating mode the outdoor fan will always run in high speed.

Door Interlock Switch When the center cabinet panel (the one with the return air grille) is removed, the interlock switch will shut down the whole unit. When this panel is replaced, the unit will be able to start up. *NOTE: This panel must be removed before either of the remaining upper or lower panels can be removed.*

Dirty Filter Switch When the filters become dirty, the dirty filter switch will activate the center light marked “Filter Service” on the front of the cabinet. After the dirty filters have been replaced the dirty filter switch must be reset by turning the reset knob counter clockwise.

Five Minute Compressor Time Delay This delay is built into the electronic heat pump control. It provides short cycle protection for the compressor.

Clogged Drain Switch This switch is mounted in the bottom of the unit behind the lower electrical box with a probe extending above the unit base pan. In the advent the drains become clogged, this switch will shut down the unit before the water level in the unit base becomes high enough to allow water to enter the indoor side. This will activate the left hand red service light marked “Drain Service” on the front of the unit. When the clogged drain is corrected and the water level in the unit base pan is at an acceptable level, the unit will start up. The switch should be operated manually at least once a year to insure the float is free to rise in the event of high water level.

OPTIONAL CLIMATE CONTROLS SEQUENCE OF OPERATION

The Climate Control **Option A** is an electronic, non-programmable manual change over thermostat. The thermostat must be manually set to the heat or cool mode. The thermostat will maintain the temperature set on the thermostat in the mode in which it is set.

The Climate Control **Option B** is an electronic, non-programmable manual change over thermostat and a four (4) hour timer. The thermostat must be manually set to the heat or cool mode. The thermostat will maintain the temperature set on the thermostat as long as the timer is on. When the set time expires, the unit will shut off and remain off until the timer is reset.

The Climate Control **Option C** is an electronic, non-programmable manual change over thermostat and a six (6) hour timer. The thermostat will maintain the temperature set on the thermostat as long as the timer is on. When the set time expires, the unit will shut off and remain off until the timer is reset.

The Climate Control **Option D** is an electronic, programmable thermostat. The thermostat can be set in the heat, cool or automatic mode. When the thermostat is set in the heat mode, it can heat only to maintain the temperature set on the thermostat. When the thermostat is set in the cool mode, it can cool only to maintain the temperature set on the thermostat. When the thermostat is set in the automatic mode, the thermostat can change automatically to the heat or cool modes to maintain the temperature set on the thermostat.

PRESSURE SERVICE PORTS

High and low pressure service ports are installed on all units so that the system operating pressures can be observed. Pressure charts can be found later in the manual covering all models on both cooling and heating cycles. It is imperative to match the correct pressure chart to the unit by model number. All service doors must be attached to obtain proper reading.

DEFROST CYCLE

The defrost cycle is controlled by temperature and time on the solid state heat pump control.

When the outdoor temperature is in the lower 40°F temperature range or colder, the outdoor coil temperature is 32°F or below. This coil temperature is sensed by the coil sensor mounted near the bottom of the outdoor coil. Once coil temperature reaches 30°F or below, the coil sends a signal to the control logic of the heat pump control and the defrost timer will start.

After 30 minutes at 30°F or below, the heat pump control will place the system in the defrost mode.

During the defrost mode the refrigerant cycle switches back to the cooling cycle, the outdoor motor stops, electric heaters are energized, and hot gas passing through the outdoor coil melts any accumulated frost. When the temperature rises to approximately 57°F, the coil sensor will send a signal to the heat pump control which will return the system to heating operations automatically.

If some abnormal or temporary condition such as a high wind causes the heat pump to have a prolonged defrost cycle, the heat pump control will restore the system to heating operation automatically after 10 minutes.

There are three settings on the heat pump control – 30 minute, 60 minute and 90 minute. Models are shipped wired on the 30 minute setting for greatest operating economy. If special circumstances require a change to another time, remove wire connected to terminal 30 and reconnect to desired terminal. Refer to Figure 18. The manufacturer's recommendation is for 30 minute defrost cycles.

There is a cycle speed up jumper on the control. This can be used to reduce the time between defrost cycle operation without waiting for time to elapse.

There is an initial defrost jumper (sen jmp) on the control that can be used at any outdoor ambient during the heating cycle to simulate a 0° coil temperature. This can be used to check defrost operation of the unit without waiting for the outdoor ambient to fall into the defrost region.

FIGURE 22 – HEAT PUMP CONTROL BOARD

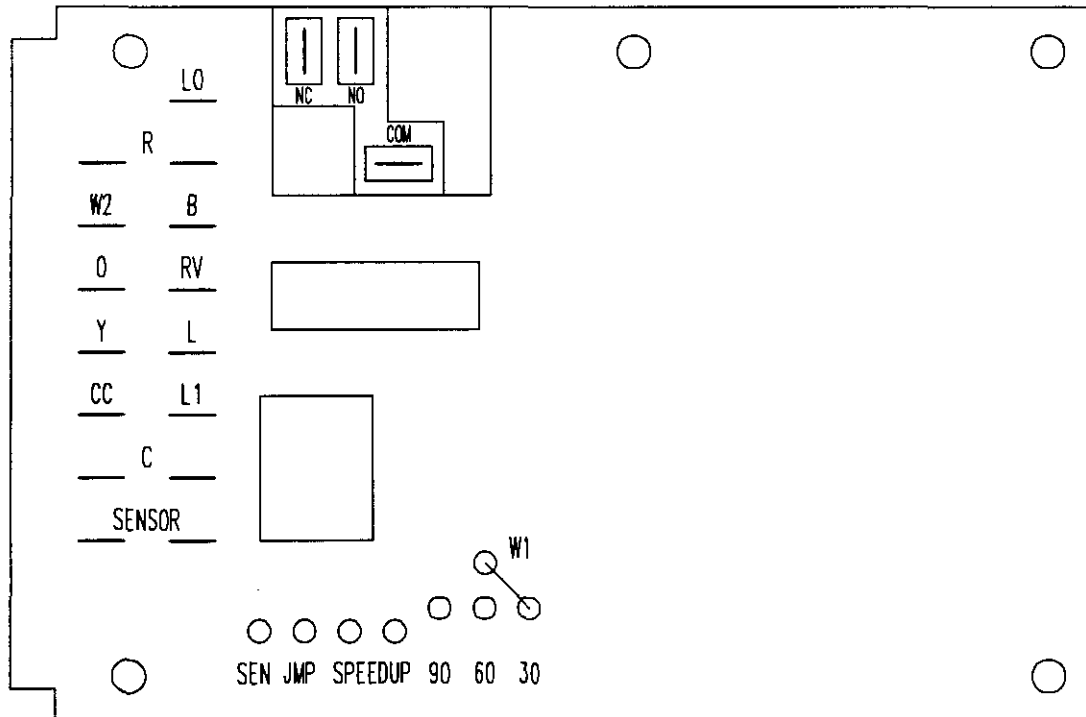

MIS-973

Troubleshooting

SOLID STATE HEAT PUMP CONTROL TROUBLESHOOTING PROCEDURE

1. Turn on AC power supply to indoor and outdoor units.
2. Turn thermostat blower switch to "fan on" – the indoor blower should start. (If it doesn't, troubleshoot indoor unit and correct problem.)

3. Turn thermostat blower to "auto" position. Indoor blower should stop.
4. Set system switch to "heat" or "cool". Adjust thermostat to call for heat or cool. The indoor blower, compressor and outdoor fan should start.

NOTE: If there was no power to 24 volt transformer, the compressor and outdoor fan motor will not start for 5 minutes. This is because of the compressor short cycle protection.

TABLE 5 – TROUBLESHOOTING

Sympton	Possible Cause	What to Check	How to Check or Repair
Compressor contactor does not energize (cooling or heating)	Control circuit wiring	Check for R connection at unit, and 24V between R-C.	Run R connection to outdoor unit to power heat pump control.
	Compressor lock out	1) Check for 24V between L1-C on heat pump control. 2) Check across high pressure switch.	1) If no voltage between L1-C turn thermostat off and on again to reset high pressure switch. 2) If high pressure switch is open and will not reset, replace high pressure switch.
	Compressor short cycle protection	Check for 24V between CC-C and Y-C on heat pump control.	If no voltage between CC-C jumper speed up terminal and within 10 seconds power should appear between CC-C. Remove speed up jumper after 10 seconds.
	Heat pump control defective	Check all other possible causes. Manual 2100-034	Replace heat pump control.
	Contactor defective	Check for open or shorted coil winding.	Replace contactor.
Fan outdoor motor does not run (cooling or heating except during defrost)	Motor defective	Check for open or shorted motor winding.	Replace motor.
	Motor capacitor defective	Check capacitor rating. Check for open or shorted capacitor.	Replace capacitor.
	Heat pump control defective	Check across fan relay on heat pump control (Com-NC)	Replace heat pump control.
Reversing valve does not energize (heating only)	Reversing valve solenoid coil defective	Check for open or shorted coil.	Replace solenoid coil.
	Heat pump control defective	Check for 24V between RV-C and B-C.	1) Check control circuit wiring. 2) Replace heat pump control
Unit will not go into defrost (heating only)	Temperature sensor or heat pump control defective	Disconnect temperature sensor from board, and jumper across speed up terminals and sen jmp terminals. This should cause the unit to go through a defrost cycle within one minute.	1) If unit goes through defrost cycle, replace temperature sensor. 2) If unit does not go through defrost cycle, replace heat pump control.
Unit will not come out of defrost (heating only)	Temperature sensor or heat pump control defective	Jumper across speed up terminals. This should cause the unit to come out of defrost within one minute.	1) If unit comes out of defrost cycle, replace temperature sensor. 2) If unit does not come out of defrost cycle, replace heat pump control.

CHECKING TEMPERATURE SENSOR

1. Disconnect temperature sensor from board and from outdoor coil.
2. Use an ohmmeter and measure the resistance of the sensor. Also use ohmmeter to check for short or open.
3. Check resistance reading to chart of resistance use sensor ambient temperature. (Tolerance of part is $\pm 10\%$.)
4. If sensor resistance reads very low, then sensor is shorted and will not allow proper operation of the heat pump control.
5. If sensor is out of tolerance, shorted, open, or reads very low ohms then it should be replaced.

TABLE 6

TEMPERATURE (F) vs RESISTANCE (R) OF TEMPERATURE SENSOR									
F	R	F	R	F	R	F	R	F	R
-25.0	196871	5.0	72910	35.0	29986	65.0	13474	95.0	6531
-24.0	190099	6.0	76070	36.0	29157	66.0	13137	96.0	6383
-23.0	183585	7.0	68507	37.0	28355	67.0	12810	97.0	6239
-22.0	177318	8.0	66418	38.0	27577	68.0	12492	98.0	6098
-21.0	171289	9.0	64399	39.0	26823	69.0	12183	99.0	5961
-20.0	165487	10.0	62449	40.0	26092	70.0	11883	100.0	5827
-19.0	159904	11.0	60565	41.0	25383	71.0	11591	101.0	5697
-18.0	154529	12.0	58745	42.0	24696	72.0	11307	102.0	5570
-17.0	149355	13.0	56985	43.0	24030	73.0	11031	103.0	5446
-16.0	144374	14.0	55284	44.0	23384	74.0	10762	104.0	5326
-15.0	139576	15.0	53640	45.0	22758	75.0	10501	105.0	5208
-14.0	134956	16.0	52051	46.0	22150	76.0	10247	106.0	5094
-13.0	130506	17.0	50514	47.0	21561	77.0	10000	107.0	4982
-12.0	126219	18.0	49028	48.0	20989	78.0	9760	108.0	4873
-11.0	122089	19.0	47590	49.0	20435	79.0	9526	109.0	4767
-10.0	118108	20.0	46200	50.0	19896	80.0	9299	110.0	4663
-9.0	114272	21.0	44855	51.0	19374	81.0	9077	111.0	4562
-8.0	110575	22.0	43554	52.0	18867	82.0	8862	112.0	4464
-7.0	107010	23.0	42295	53.0	18375	83.0	8653	113.0	4367
-6.0	103574	24.0	41077	54.0	17898	84.0	8449	114.0	4274
-5.0	100260	25.0	39898	55.0	17434	85.0	8250	115.0	4182
-4.0	97064	26.0	38757	56.0	16984	86.0	8057	116.0	4093
-3.0	93981	27.0	37652	57.0	16547	87.0	7869	117.0	4006
-2.0	91008	28.0	38583	58.0	16122	88.0	7686	118.0	3921
-1.0	88139	29.0	35548	59.0	15710	89.0	7507	119.0	3838
0.0	85371	30.0	34545	60.0	15310	90.0	7334	120.0	3757
1.0	82699	31.0	33574	61.0	14921	91.0	7165	121.0	3678
2.0	80121	32.0	32634	62.0	14544	92.0	7000	122.0	3601
3.0	77632	33.0	31723	63.0	14177	93.0	6840	123.0	3526
4.0	75230	34.0	30840	64.0	13820	94.0	6683	124.0	3452

FAN BLADE SETTING DIMENSIONS

Any service work requiring removal or adjustment in the fan and/or motor area will require that the dimensions in Table 7 be checked and blade adjusted in or out of the motor shaft accordingly.

FIGURE 23 – FAN BLADE SETTING

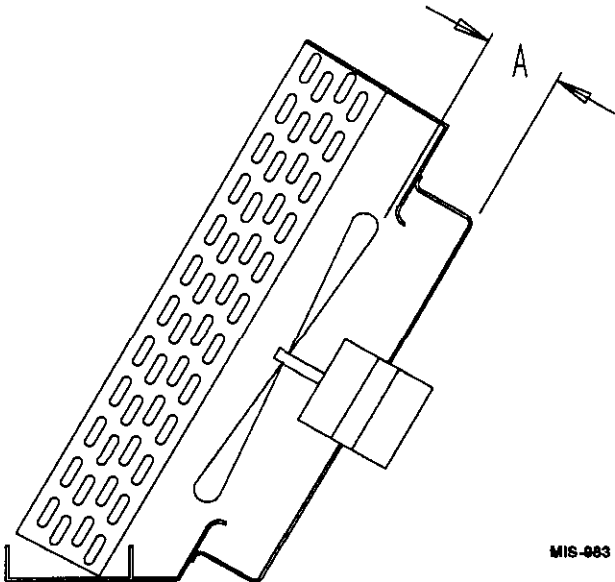

TABLE 7 – FAN BLADE DIMENSIONS

MODEL	DIMENSION A (INCHES)
QH241	.750
QH301	.750
QH361	.750
QH421	.750
QH481	.750

REFRIGERANT CHARGE

The correct system R-22 charge is shown on the unit rating plate. Optimum unit cooling performance will occur with a refrigerant charge resulting in a Super Heat as shown in Table 8. If correct charge is in doubt, recover the refrigerant and recharge per the charge on the unit rating plate.

TABLE 8 – SUPER HEAT AT COMPRESSOR

MODEL	RATED CFM	95 F OD TEMPERATURE	82 F OD TEMPERATURE
QH241	800	16 - 18	14 - 16
QH301	1000	16 - 18	15 - 17
QH361	1200	16 - 18	14 - 16
QH421	1200	19 - 21	16 - 18
QH481	1200	23 - 25	22 - 24

TABLE 9 – INDOOR BLOWER PERFORMANCE

MODEL	RATED ESP	① MAX. ESP	② RATED CFM	③ OPTIONAL CFM	④ CONTINUOUS CFM	⑤ DEHUMIDIFICATION CFM	CFM @ MAX. ESP
QH241 ⑥	.10	0.5	800		800	500	700
QH301	.15	0.8	1000		1000	700	910
QH361	.15	0.8	1200	1000	1000	850	1175
QH421	.15	0.8	1200	1000	1000	850	1175
QH481	.15	0.8	1400	1100	1100	850	1175

NOTE: These units are equipped with a variable speed (ECM) indoor motor that automatically adjust itself to maintain approximately the same rate of indoor air flow in both heating and cooling, dry and wet coil conditions and at both 230/208 or 460 volts.

- ① Maximum ESP (inches WC) shown is with 1" thick disposable filter (reduced by .2 for 2" filter).
- ② **Rated CFM** for ducted applications – required for maximum performance rating. To obtain full CFM on models QH361 and QH421, connect the pink jumper wire (provided) to terminal #5 and #6 on the low voltage terminal block located in the circuit breaker box.
- ③ **Optional CFM** – the unit is shipped from the factory set to operate at the optional CFM level shown. This provides lower operating sound levels for non-ducted, free discharge applications. This reduces system capacity performance by approximately 2% at the same energy efficiency.
- ④ **Continuous fan CFM** is the total air being circulated during continuous fan mode.
- ⑤ **Indoor air flow during periods of high humidity** when system is operating under control of optional humidistat for maximum humidity reduction.
- ⑥ **Models QH241** – when operating on 2nd stage heating the indoor air will increase to 1000 CFM.

PRESSURE CHARTS

TABLE 10 – COOLING PRESSURE – (All Temperatures in Degrees F)

MODEL	RETURN AIR TEMP.	PRESSURE	AIR TEMPERATURE ENTERING OUTDOOR COIL								
			75 ①	80	85	90	95	100	105	110	115
QH241	75 DB	Low Side	73	73	74	76	77	79	80	81	83
	62 WB	High Side	195	199	214	229	244	259	274	289	304
	80 DB	Low Side	78	78	79	80	82	84	85	87	88
	67 WB	High Side	203	204	219	234	250	264	280	296	312
	85 DB	Low Side	84	84	85	86	88	89	91	93	94
	72 WB	High Side	121	213	228	244	259	274	290	305	320
QH301	75 DB	Low Side	75	75	76	77	78	79	80	81	82
	62 WB	High Side	226	202	242	258	273	319	303	319	335
	80 DB	Low Side	80	80	81	82	83	84	85	86	87
	67 WB	High Side	228	233	248	264	280	296	311	327	343
	85 DB	Low Side	86	86	87	88	89	90	91	92	93
	72 WB	High Side	238	240	257	273	290	306	323	339	356
QH361	75 DB	Low Side	74	74	75	76	77	78	79	80	81
	62 WB	High Side	212	215	233	251	269	287	305	323	341
	80 DB	Low Side	79	79	80	81	82	83	84	85	86
	67 WB	High Side	219	220	239	257	276	294	312	331	350
	85 DB	Low Side	85	85	86	87	88	89	90	91	92
	72 WB	High Side	223	228	247	267	286	305	324	343	363
QH421	75 DB	Low Side	71	71	72	73	74	75	76	77	79
	62 WB	High Side	246	248	264	281	299	318	339	362	385
	80 DB	Low Side	75	76	77	78	79	80	81	82	83
	67 WB	High Side	251	243	270	288	307	327	349	371	395
	85 DB	Low Side	82	82	83	84	85	86	87	88	90
	72 WB	High Side	261	262	279	298	318	330	361	384	409
QH481	75 DB	Low Side	69	71	72	72	73	74	75	75	76
	62 WB	High Side	221	237	252	270	287	305	323	343	363
	80 DB	Low Side	75	76	76	77	78	79	80	80	81
	67 WB	High Side	228	244	260	276	294	312	331	351	372
	85 DB	Low Side	81	82	82	83	84	85	86	86	87
	72 WB	High Side	237	252	269	285	304	323	342	363	385

Low side pressure \pm 2 psig

High side pressure \pm 5 psig

Tables are based upon rated CFM (airflow) across the evaporator coil. If there is any doubt as to correct operating charge being in the system, the charge should be removed, system evacuated and recharged to serial plate instructions.

① 75° F outdoor temperature condenser fan motor is running on low speed.

TABLE 11 – HEATING PRESSURE – (All Temperatures in Degrees F)

MODEL	RETURN AIR TEMP.	PRESSURE	AIR TEMPERATURE ENTERING OUTDOOR COIL													
			0	5	10	15	17	20	25	30	35	40	47	50	55	60
QH241	70	Low Side	7	12	17	23	25	28	33	39	44	50	57	60	65	71
		High Side	147	155	164	172	176	181	189	198	206	215	227	232	240	249
QH301	70	Low Side	16	20	24	28	30	33	37	41	45	49	55	58	62	67
		High Side	157	163	169	175	177	180	187	193	199	205	213	217	222	228
QH361	70	Low Side	13	17	21	25	27	30	34	38	42	46	52	55	59	63
		High Side	147	153	159	164	167	171	176	182	188	194	202	206	211	217
QH421	70	Low Side	13	18	22	26	28	31	35	39	44	48	54	57	61	65
		High Side	161	168	174	180	183	187	193	199	206	212	221	225	231	237

OPTIONAL ACCESSORIES

MODEL	DESCRIPTION
QLG-10	Outdoor lower grille, clear anodized aluminum for 2, 2-1/2, 3, 3-1/2 Ton QTEC Models
QLG-15	Outdoor lower grille, clear anodized aluminum for 4 Ton QTEC Models
QLG-20	Outdoor lower grille, medium bronze anodized aluminum for 2, 2-1/2, 3, 3-1/2 Ton QTEC Models
QLG-25	Outdoor lower grille, medium bronze anodized aluminum for 4 Ton QTEC Models
QLG-30	Outdoor lower grille, dark bronze anodized aluminum for 2, 2-1/2, 3, 3-1/2 Ton QTEC Models
QLG-35	Outdoor lower grille, dark bronze anodized aluminum for 4 Ton QTEC Models
QWS42	14 Inch wall sleeve for 2, 2-1/2, 3, 3-1/2 Ton QTEC Models. <i>Required for all units.</i>
QWS48	14 Inch wall sleeve for 4 Ton QTEC Models. <i>Required for all units.</i>
GSTX42	Side trim piece extension for 2, 2-1/2, 3, 3-1/2 Ton QTEC Models. Provides cabinet extension between interior wall and unit when wall thickness is between 5 inches and 12 inches.
QPB42	Free blow plenum box for 2, 2-1/2, 3, 3-1/2 Ton QTEC Models. Includes front supply grilles.
QPB48	Free blow plenum box for 4 Ton QTEC Models. Includes front supply grilles.
QCX-10	Cabinet extension for ducted applications on 2, 2-1/2, 3, 3-1/2 Ton QTEC Models. Height will be 20 inches high.
QCX-15	Cabinet extension for ducted applications on 4 Ton QTEC Models. Height will be 20 inches high.

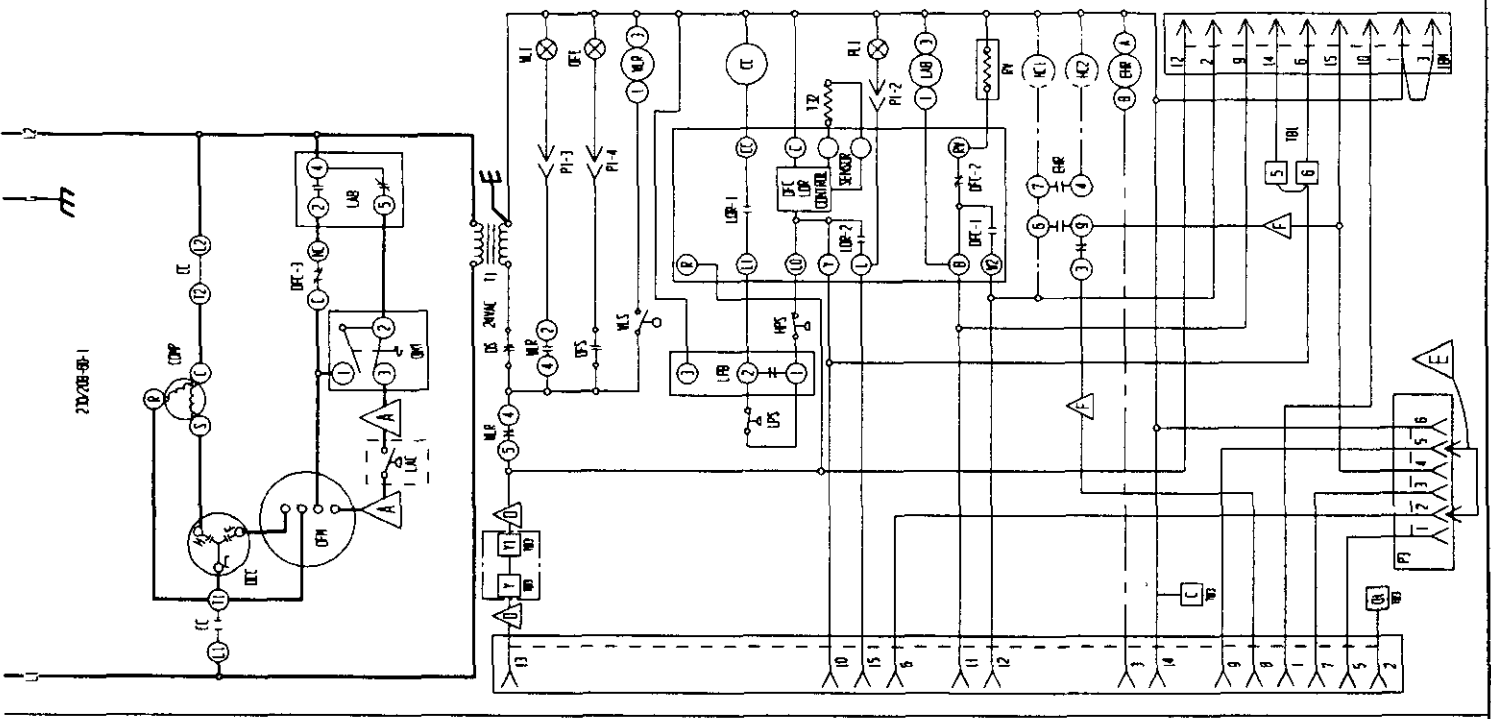
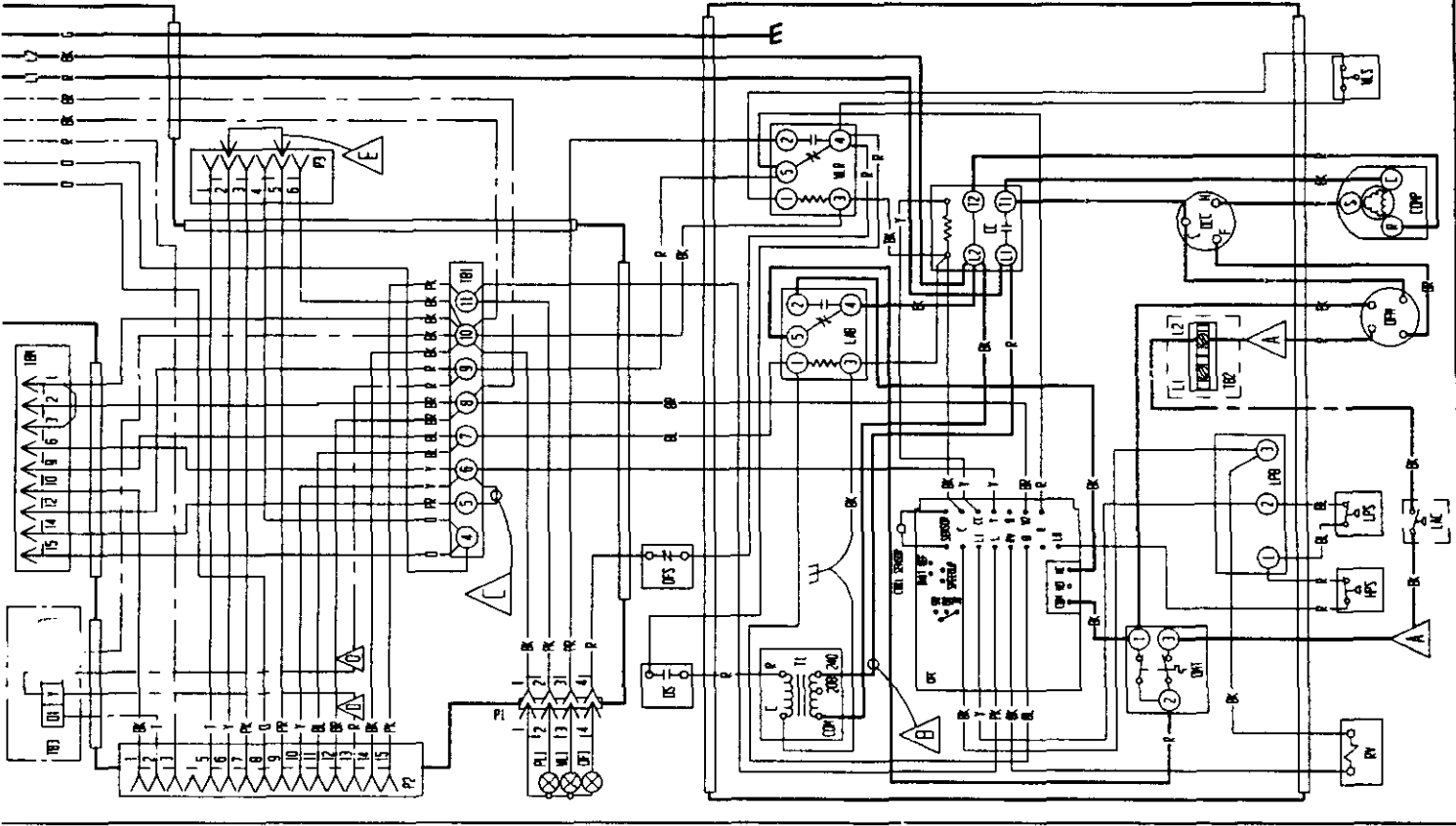

COMPONENTS

C1	COMPRESSOR CONTACTOR
C2	COMPRESSOR CONTACTOR
C3	COMPRESSOR CONTACTOR
C4	COMPRESSOR CONTACTOR
C5	COMPRESSOR CONTACTOR
C6	COMPRESSOR CONTACTOR
C7	COMPRESSOR CONTACTOR
C8	COMPRESSOR CONTACTOR
C9	COMPRESSOR CONTACTOR
C10	COMPRESSOR CONTACTOR
C11	COMPRESSOR CONTACTOR
C12	COMPRESSOR CONTACTOR
C13	COMPRESSOR CONTACTOR
C14	COMPRESSOR CONTACTOR
C15	COMPRESSOR CONTACTOR
C16	COMPRESSOR CONTACTOR
C17	COMPRESSOR CONTACTOR
C18	COMPRESSOR CONTACTOR
C19	COMPRESSOR CONTACTOR
C20	COMPRESSOR CONTACTOR
C21	COMPRESSOR CONTACTOR
C22	COMPRESSOR CONTACTOR
C23	COMPRESSOR CONTACTOR
C24	COMPRESSOR CONTACTOR
C25	COMPRESSOR CONTACTOR
C26	COMPRESSOR CONTACTOR
C27	COMPRESSOR CONTACTOR
C28	COMPRESSOR CONTACTOR
C29	COMPRESSOR CONTACTOR
C30	COMPRESSOR CONTACTOR
C31	COMPRESSOR CONTACTOR
C32	COMPRESSOR CONTACTOR
C33	COMPRESSOR CONTACTOR
C34	COMPRESSOR CONTACTOR
C35	COMPRESSOR CONTACTOR
C36	COMPRESSOR CONTACTOR
C37	COMPRESSOR CONTACTOR
C38	COMPRESSOR CONTACTOR
C39	COMPRESSOR CONTACTOR
C40	COMPRESSOR CONTACTOR
C41	COMPRESSOR CONTACTOR
C42	COMPRESSOR CONTACTOR
C43	COMPRESSOR CONTACTOR
C44	COMPRESSOR CONTACTOR
C45	COMPRESSOR CONTACTOR
C46	COMPRESSOR CONTACTOR
C47	COMPRESSOR CONTACTOR
C48	COMPRESSOR CONTACTOR
C49	COMPRESSOR CONTACTOR
C50	COMPRESSOR CONTACTOR
C51	COMPRESSOR CONTACTOR
C52	COMPRESSOR CONTACTOR
C53	COMPRESSOR CONTACTOR
C54	COMPRESSOR CONTACTOR
C55	COMPRESSOR CONTACTOR
C56	COMPRESSOR CONTACTOR
C57	COMPRESSOR CONTACTOR
C58	COMPRESSOR CONTACTOR
C59	COMPRESSOR CONTACTOR
C60	COMPRESSOR CONTACTOR
C61	COMPRESSOR CONTACTOR
C62	COMPRESSOR CONTACTOR
C63	COMPRESSOR CONTACTOR
C64	COMPRESSOR CONTACTOR
C65	COMPRESSOR CONTACTOR
C66	COMPRESSOR CONTACTOR
C67	COMPRESSOR CONTACTOR
C68	COMPRESSOR CONTACTOR
C69	COMPRESSOR CONTACTOR
C70	COMPRESSOR CONTACTOR
C71	COMPRESSOR CONTACTOR
C72	COMPRESSOR CONTACTOR
C73	COMPRESSOR CONTACTOR
C74	COMPRESSOR CONTACTOR
C75	COMPRESSOR CONTACTOR
C76	COMPRESSOR CONTACTOR
C77	COMPRESSOR CONTACTOR
C78	COMPRESSOR CONTACTOR
C79	COMPRESSOR CONTACTOR
C80	COMPRESSOR CONTACTOR
C81	COMPRESSOR CONTACTOR
C82	COMPRESSOR CONTACTOR
C83	COMPRESSOR CONTACTOR
C84	COMPRESSOR CONTACTOR
C85	COMPRESSOR CONTACTOR
C86	COMPRESSOR CONTACTOR
C87	COMPRESSOR CONTACTOR
C88	COMPRESSOR CONTACTOR
C89	COMPRESSOR CONTACTOR
C90	COMPRESSOR CONTACTOR
C91	COMPRESSOR CONTACTOR
C92	COMPRESSOR CONTACTOR
C93	COMPRESSOR CONTACTOR
C94	COMPRESSOR CONTACTOR
C95	COMPRESSOR CONTACTOR
C96	COMPRESSOR CONTACTOR
C97	COMPRESSOR CONTACTOR
C98	COMPRESSOR CONTACTOR
C99	COMPRESSOR CONTACTOR
C100	COMPRESSOR CONTACTOR

USE COPPER CONDUCTORS ONLY
SUITABLE FOR AT LEAST 75°C

A **D** **F** LABELED WIRES CONNECT IF NO OPTIONS USED

B NONE RED WIRE TO ZEB Y TAP FOR ZEB Y OPERATION

C INITIAL JUMPER FOR HIGH SPEED BLOWER OPERATION ON MODES 3, 4 & 5

E IF WENT OPTION IS INSTALLED, PLUG WITH JUMPER 2 TO 5 IS REQUIRED & PLUG FROM WENT OPTION INSTALLED

FACTORY	FIELD	OPTIONAL
HIGH VOLTAGE		
LOW VOLTAGE		
ACCESSORY		

BK - BLACK
 BR - BROWN
 P - RED
 D - ORANGE
 Y - YELLOW
 G - GREEN
 B - BLUE
 W - WHITE
 T - TAN
 PK - PINK
 L - LAMP
 C - CRYSTAL

4100-101C

- DB CIRCUIT BREAKER #1
- DL OPERATOR CONDUCTOR
- DM OPERATOR CONDUCTOR
- DN OPERATOR CONDUCTOR
- DP OPERATOR CONDUCTOR
- DR OPERATOR CONDUCTOR
- DS OPERATOR CONDUCTOR
- DT OPERATOR CONDUCTOR
- DU OPERATOR CONDUCTOR
- DV OPERATOR CONDUCTOR
- DW OPERATOR CONDUCTOR
- DX OPERATOR CONDUCTOR
- DY OPERATOR CONDUCTOR
- DZ OPERATOR CONDUCTOR
- EA OPERATOR CONDUCTOR
- EB OPERATOR CONDUCTOR
- EC OPERATOR CONDUCTOR
- ED OPERATOR CONDUCTOR
- EE OPERATOR CONDUCTOR
- EF OPERATOR CONDUCTOR
- EG OPERATOR CONDUCTOR
- EH OPERATOR CONDUCTOR
- EI OPERATOR CONDUCTOR
- EJ OPERATOR CONDUCTOR
- EK OPERATOR CONDUCTOR
- EL OPERATOR CONDUCTOR
- EM OPERATOR CONDUCTOR
- EN OPERATOR CONDUCTOR
- EO OPERATOR CONDUCTOR
- EP OPERATOR CONDUCTOR
- EQ OPERATOR CONDUCTOR
- ER OPERATOR CONDUCTOR
- ES OPERATOR CONDUCTOR
- ET OPERATOR CONDUCTOR
- EU OPERATOR CONDUCTOR
- EV OPERATOR CONDUCTOR
- EW OPERATOR CONDUCTOR
- EX OPERATOR CONDUCTOR
- EY OPERATOR CONDUCTOR
- EZ OPERATOR CONDUCTOR

USE COPPER CONDUCTORS ONLY
SUITABLE FOR AT LEAST 75°C

▲ A/D LABELLED WIRES CONNECT IF NO OPTIONS USED

▲ B NONE AND WIRE TO ZERO 1/4" (20) TOLERANCE

▲ C INSTANTaneous OVER CURRENT PROTECTION ON CIRCUITS 3 & 4 WITH LAMP 2 (0.5) IS REQUIRED & RFD FROM MAIN OPTION INSTALLED

▲ E IF MAIN OPTION IS INSTALLED, RING WITH LAMP 2 (0.5) IS REQUIRED & RFD FROM MAIN OPTION INSTALLED

FACTORY STD	FIELD	OPTIONAL

HIGH VOLTAGE

LOW VOLTAGE

ACCESSORY

BK - BLACK
 BR - BROWN
 P - RED
 O - ORANGE
 Y - YELLOW
 G - GREEN
 B - BLUE
 PR - PURPLE
 GR - GREY
 W - WHITE
 I - TAN
 R - PINK
 L - LAMPRED

4100-102 D

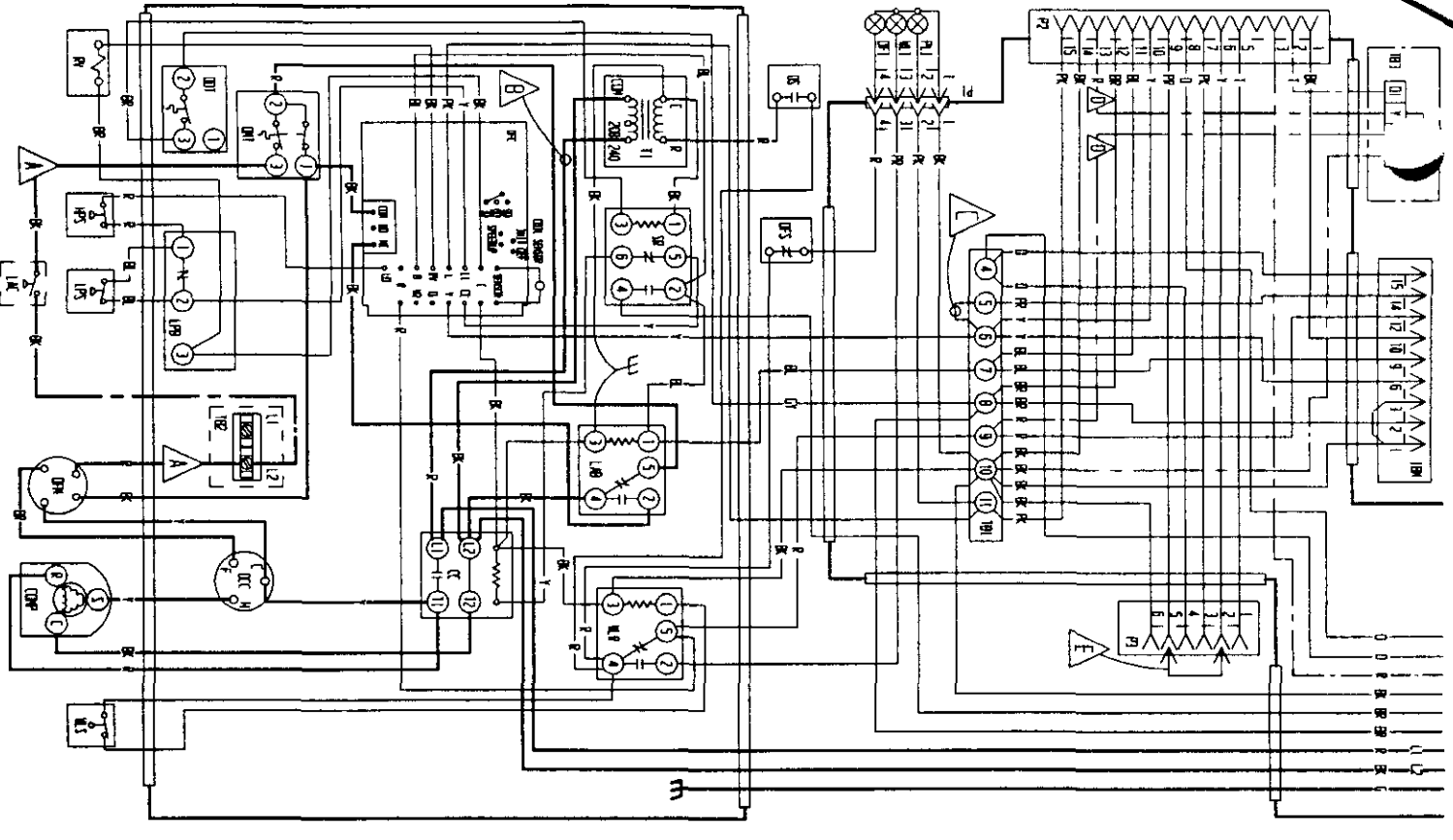
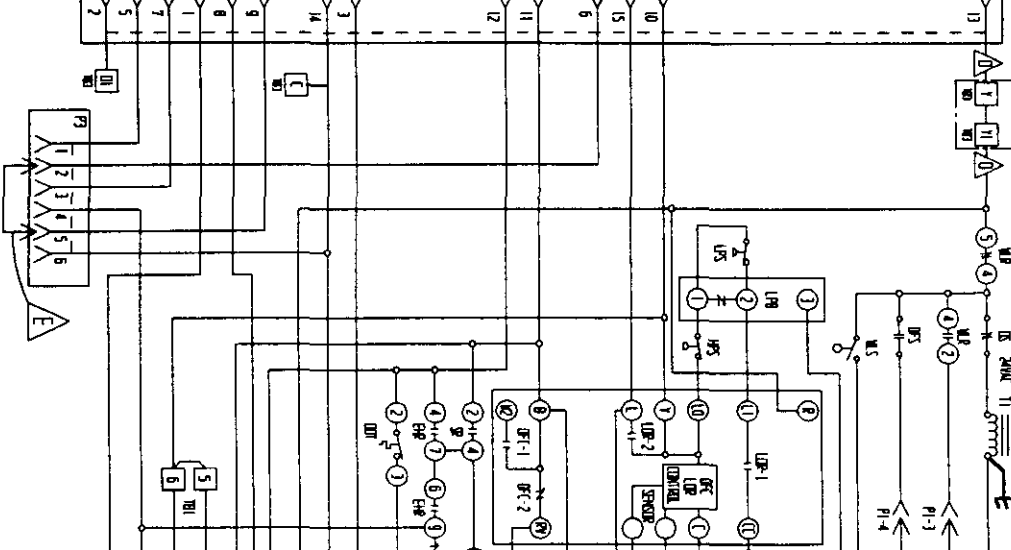
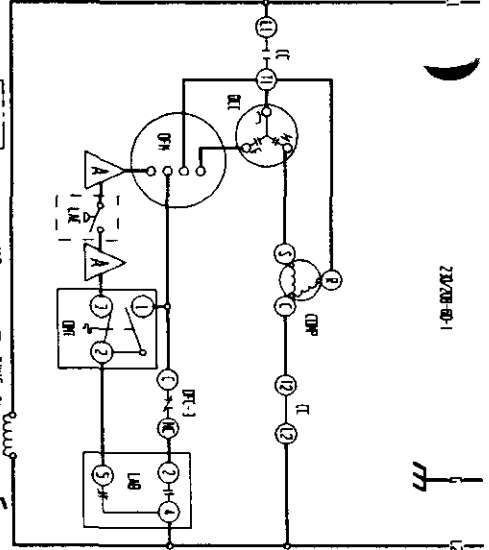

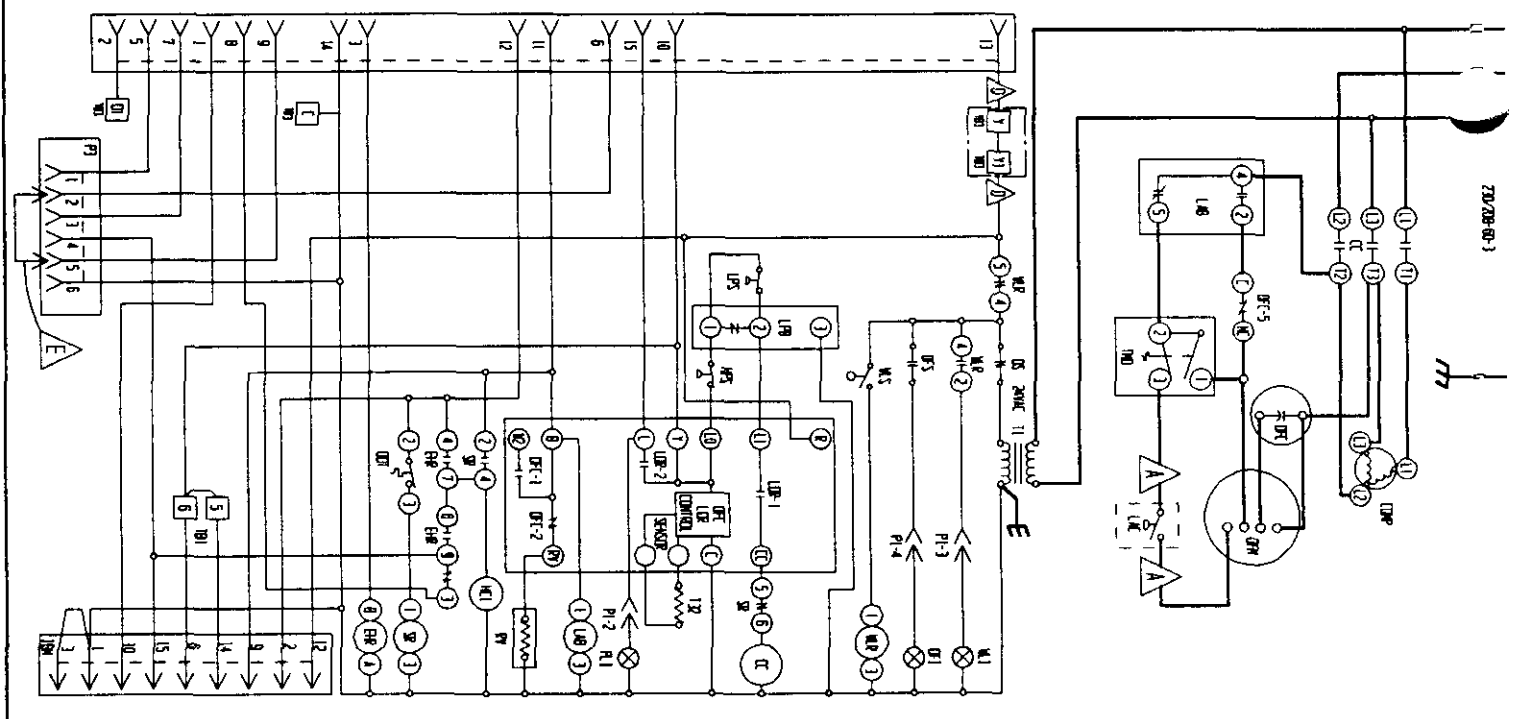
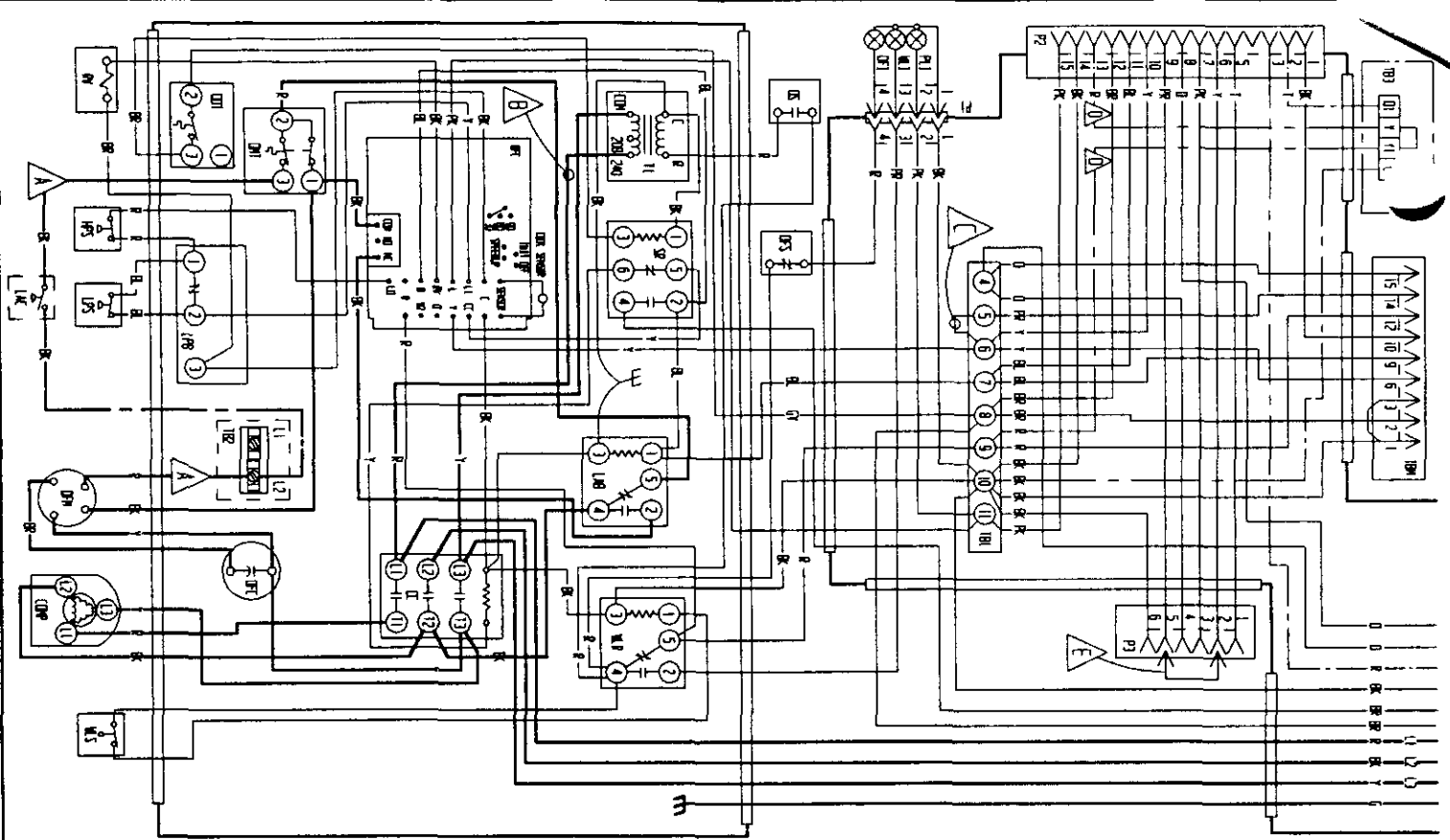

COMPONENTS

- (B) CIRCUIT BREAKER
- (C) CONTACTOR
- (F) FUSE
- (I) INDICATOR LAMP
- (K) KEYS
- (L) LIMIT SWITCH
- (M) MOTOR
- (N) NOT USED
- (P) PRESSURE SWITCH
- (R) RELAY
- (S) STOP SWITCH
- (T) THERMISTOR
- (U) UNDER PNEUMATIC
- (V) UNDER PNEUMATIC
- (W) UNDER PNEUMATIC
- (X) UNDER PNEUMATIC
- (Y) UNDER PNEUMATIC
- (Z) UNDER PNEUMATIC
- (AA) UNDER PNEUMATIC
- (AB) UNDER PNEUMATIC
- (AC) UNDER PNEUMATIC
- (AD) UNDER PNEUMATIC
- (AE) UNDER PNEUMATIC
- (AF) UNDER PNEUMATIC
- (AG) UNDER PNEUMATIC
- (AH) UNDER PNEUMATIC
- (AI) UNDER PNEUMATIC
- (AJ) UNDER PNEUMATIC
- (AK) UNDER PNEUMATIC
- (AL) UNDER PNEUMATIC
- (AM) UNDER PNEUMATIC
- (AN) UNDER PNEUMATIC
- (AO) UNDER PNEUMATIC
- (AP) UNDER PNEUMATIC
- (AQ) UNDER PNEUMATIC
- (AR) UNDER PNEUMATIC
- (AS) UNDER PNEUMATIC
- (AT) UNDER PNEUMATIC
- (AU) UNDER PNEUMATIC
- (AV) UNDER PNEUMATIC
- (AW) UNDER PNEUMATIC
- (AX) UNDER PNEUMATIC
- (AY) UNDER PNEUMATIC
- (AZ) UNDER PNEUMATIC

USE COPPER CONDUCTORS ONLY
 SUITABLE FOR AT LEAST 75°C
 (SEE WIRE CONNECTIONS)

INDICATOR LAMP FOR HIGH SPEED
 BLOCK OPERATION ON KEYS B 1 &
 C WITH JUMPER 2 TO 5 IS REQUIRED &
 ALSO FROM MAIN SWITCH INDICATOR

KEYS	RED	STOP
KEYS	GREEN	START
KEYS	YELLOW	STOP

4100-2020

COMPONENT	DESCRIPTION
DB1	CIRCUIT BREAKER
DB2	COMPRESSOR CONTACTOR
DB3	DEFROST CONTACTOR
DB4	DIRTY FILTER INDICATOR
DB5	DIRTY FILTER SWITCH
DB6	DIRTY SWITCH
DB7	EMERGENCY HEAT RELAY
DB8	FUSE CLASS (CSA OR IEC)
DB9	GRAB
DB10	HEATER CONTACTOR #1
DB11	HEATER CONTACTOR #2
DB12	HIGH PRESSURE SWITCH
DB13	HEAT STRIP #1
DB14	HEAT STRIP #2
DB15	LOW AMBIENT CONTACTOR
DB16	LOW AMBIENT CONTACTOR
DB17	LOW PRESSURE SWITCH
DB18	LOW PRESSURE SWITCH
DB19	LOW PRESSURE SWITCH
DB20	LOW PRESSURE SWITCH
DB21	LOW PRESSURE SWITCH
DB22	QUICK FAN CONTACTOR
DB23	QUICK FAN MOTOR
DB24	QUICK FAN THERMISTAT
DB25	ACCESSORY PLUG #1
DB26	ACCESSORY PLUG #2
DB27	ACCESSORY PLUG #3
DB28	PRESSURE LOCUCON INDICATOR
DB29	REF. VALVE SOLINOID
DB30	TRANSFORMER #1
DB31	TRANSFORMER #2
DB32	TERMINAL BLOCK #1
DB33	TERMINAL BLOCK #2
DB34	TERMINAL BLOCK #3
DB35	TERMINAL BLOCK #4
DB36	QUICK AUTO RELAY
DB37	HIGH WATER LEVEL INDICATOR
DB38	WATER LEVEL RELAY
DB39	WATER LEVEL SWITCH

USE COPPER CONDUCTORS ONLY
SUITABLE FOR AT LEAST 75°C

LABELLED WIRES CONNECT IF NO OPTIONS USED
 MAKE RED WIRE TO JOB Y
 TAP FOR JOB Y OPERATION
 INSTALL JUMPER FOR HIGH SPEED
 BLOWER OPERATION ON MODELS 25 & 42
 IF VENT OPTION IS INSTALLED, PLUG WITH JUMPER 2 TO 5 IS REQUIRED & PLUG FROM VENT OPTION INSERTED

FACTORY	FIELD	OPTIONAL
HIGH VOLTAGE		
LOW VOLTAGE		
ACCESSORY		

BR - BLACK	G - GREEN	I - TAN
BN - BROWN	B - BLUE	P - PINK
R - RED	BU - BLUE	L - LAMP/RED
O - ORANGE	GY - GREY	
Y - YELLOW	W - WHITE	

4100-301 E

