INSTALLATION INSTRUCTIONS

WAG - SERIES COMBINATION GAS/ELECTRIC WALL-MOUNT

MODELS:

WAG30D

WAG36D

WAG40D

WAG30E

WAG36E

WAG40E



WARNING

READ ALL INSTRUCTIONS CAREFULLY BEFORE BEGINNING THE INSTALLATION.

THE INSTALLATION MUST COMPLY WITH THESE INSTRUCTIONS AND THE REQUIREMENTS OF ALL GOVERNING CODES AND ORDINANCES FOR THE INSTALLATION LOCATION.

IT IS THE RESPONSIBILITY OF INSTALLER TO KNOW AND UNDERSTAND ALL OF THESE REQUIREMENTS.

FAILURE TO DO SO COULD CREATE A HAZARD RESULTING IN PROPERTY DAMAGE, BODILY INJURY, OR DEATH.



Bard Manufacturing Company
Bryan, Ohio 43506

*Since 1914...Moving ahead, just as
planned.*

Manual No.: 2100-278C
File: Volume III, Tab 20
Date: 08-23-00

Contents

	Page		Page
Getting Other Information and Publications	1	18. Standard Orifice Sizing and High Altitude Derate	12
WAG - Series Model Nomenclature	3	19. Conversion of Gas Input BTUH From High to Low Rating	14
1. Important	3	20. Measuring Air Temperature Rise	15
2. Application	3	21. Filters	15
3. High Altitude Applications	4	22. Standard Equipment (Canadian Units Only) .	15
4. Transportation Damage	4	23. Lighting and Shutdown Instructions	17
5. Installation	4	24. Service Agency Procedures	18
6. Wall Mounting	4	25. Maintenance Instructions	19
7. Clearances	7	26. Replacement Parts	19
8. Duct Work	7	27. Sequence of Operation – Heating	19
9. Mounting Brackets	7	28. Sequence of Operation – Cooling	20
10. Vent Terminal and Induced Draft Blower Hood	7	29. Indoor Blower Operation	20
11. Vent Resizing Instructions	7	30. Smartvalve™ HSI Ignition Troubleshooting Flow Chart	23
12. Fresh Air Damper Assembly	8	31. Pressure Service Ports	24
13. Wiring	8	32. Refrigerant Charge	24
14. Thermostat	9	33. Fan Blade Setting Dimensions	225
15. Gas Supply and Piping	9	34. Lo-NOx Burner Assembly X Suffix Models Only	25
16. Manifold Pressure Adjustment	11	Wiring Diagrams	26-35
17. Checking Gas Input Rate	11		

Figures

Figure 1	5
Figure 2	6
Figure 3	6
Figure 3-A	8
Figure 4	10
Figure 5	10
Figure 6	17
Figure 7	18
Figure 8	18
Figure 9	18
Figure 10	20
Figure 11	21
Figure 12	22
Figure 13	25
Figure 14	25

Tables

Table 1	2
Table 2	7
Table 3	9
Table 4	9
Table 5	10
Table 6	10
Table 7	13
Table 8	14
Table 9	24
Table 10	24
Table 11	25

Getting Other Information and Publications

These publications can help you install the furnace. You can usually find these at your local library or purchase them directly from the publisher. Be sure to consult current edition of each standard.

National Fuel Gas Code ANSI Z223.1 / NFPA 54

National Electrical Code ANSI / NFPA 70

Standard for the Installation of ANSI / NFPA 90A
Air Conditioning and Ventilating Systems

Standard for Warm Air Heating ANSI / NFPA 90B
and Air Conditioning Systems

Standard for Chimneys, Fireplaces, Vents, NFPA 211
and Solid Fuel Burning Appliances

Load Calculation for Residential ACCA Manual J
Winter and Summer Air Conditioning

Duct Design for Residential Winter ACCA Manual D
and Winter Air Conditioning and
Equipment Selection

Canadian Electrical Code CSA C22.1

Canadian Installation Code CAN/CGA B149

For more information, contact these publishers:

ACCA — Air Conditioning Contractors of America
1712 New Hampshire Avenue, NW
Washington, DC 20009
Telephone: (202) 483-9370

ANSI — American National Standards Institute
11 West Street, 13th Floor
New York, NY 10036
Telephone: (212) 642-4900
Fax: (212) 302-1286

**ASHRAE — American Society of Heating Refrigerating,
and Air Conditioning Engineers,
Incorporated**
1791 Tullie Circle, NE.
Atlanta, GA 30329-2305
Telephone: (404) 636-8400
Fax: (404) 321-5478

NFPA — National Fire Protection Association
Batterymarch Park
P.O. Box 9101
Quincy, MA 02269-9901
Telephone: (800) 344-3555
Fax: (617) 984-7057

CSA — Canadian Standards Association
178 Rexdale Boulevard
Rexdale, Ontario
Canada. M9W 1R3
Telephone: (416) 447-4044

COPYRIGHT AUGUST 2000
BARD MANUFACTURING COMPANY
BRYAN, OHIO 43506 USA

TABLE 1

SPECIFICATIONS							
Model	WAG30D-A54C	WAG36D-A54C	WAG36D-B54C	WAG36D-C54C	WAG40D-A54C	WAG40D-B54C	WAG40D-C54C
† Cooling Capacity Btuh	30,000	35,000	35,000	35,000	38,500	38,500	38,500
Heating Input (M/Btuh)	65/55	65/55	65/55	65/55	65/55	65/55	65/55
Heating Output (M/Btuh)	51/43	51/43	51/43	51/43	51/43	51/43	51/43
Temperature Rise Range	50 - 80	50 - 80	50 - 80	50 - 80	50 - 80	50 - 80	50 - 80
<i>Electrical Rating 60HZ</i>							
Operating Voltage Range	197-253	197-253	187-253	414-506	197-253	187-253	414-506
Minimum Circuit Ampacity	23	30	21	15	31	23	15
* Field Wire Size / Ground Wire Size	8/10	8/10	10/10	14/14	8/10	10/10	14/14
** Delay Fuse Max.	35	40	30	15	45	30	15
Max. Unit Amps	18.5	24.5	17.4	9.0	23.7	17.6	10.6
<i>Compressor Circuit A</i>							
Volts	230/208	230/208	230/208	460	230/208	230/208	460
Rated Load Amps 230/208	14.3/15.3	18.0/20.3	11.4/13.2	4.8	18.1/19.5	12.4/13.4	6.4
Branch Circuit Selection Current	15.3	20.3	13.2	4.8	19.5	13.4	6.4
Lock Motor Amps	75	96	75	40	102	91	42
<i>Fan Motor and Compressor</i>							
Fan Motor HP/RPM	1/5 / 1090	1/3 / 1110		1/3 / 1110			
Fan Motor Amps	1.4	2.4		2.4			
Fan DIA/CFM	20 / 2100	20 / 2100		20 / 2100			
Face Area Sq.Ft/Rows/Fins per in.	5.04/2/13	5.04/3/11		5.04/4/13			
<i>Motor and Evaporator</i>							
Blower Motor HP/RPM	1/3 / 1085	1/3 / 1085		1/3 / 1085			
Blower Motor Amps	1.8	1.8		1.8			
CFM Cooling & E.S.P. w/Filter (Rated)	1000/.15	1000/.15		1000/.15			
Face Area Sq.Ft/Rows/Fins per in.	3.21/2/13	3.21/3/13		3.21/3/13			
Filter Sizes (Inches)	20x30x1	20x30x1		20x30x1			
Refrigerant 22 oz.	73.5	94	94	94	106	106	106
Shipping Weight lbs.	525	525	525	525	525	525	525

* 60 degree C Copper wire size

** Maximum time delay fuse or HACR Type circuit breaker

† All capacity, efficiency, and cost of operation information is in accordance with DOE and/or ARI test procedures. This information is based on high speed cooling and low speed heating operation using a fresh air cover plate. Cover plate must be ordered separately and is recommended for use to obtain maximum energy efficiency where fresh air opening is not required.

All units shipped with high input orifices installed. Low input orifices are included for field changeover.

WAG - Series Model Nomenclature

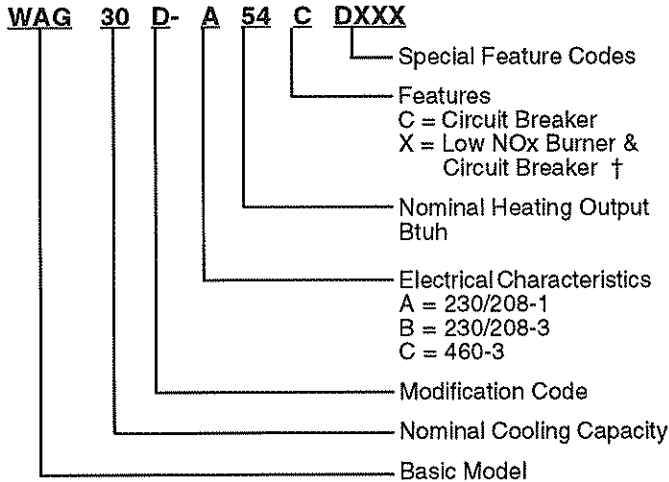

† - "X" suffix low NOx models not approved for propane gas conversion

Special Feature Code - D055 - CGA Approved Models Models Approved:

WAG30D-A54CD055	WAG30E-A54CD055
WAG36D-A54CD055	WAG36E-A54CD055
WAG36D-B54CD055	WAG36E-B54CD055
WAG40D-A54CD055	WAG40E-A54CD055
WAG40D-B54CD055	WAG40E-B54CD055

1. IMPORTANT

The equipment covered in this manual is to be installed by trained, experienced service and installation technicians. All duct work supply and return must be properly sized for the design air flow requirement of the equipment. ACCA is an excellent guide to proper sizing. All duct work or portions thereof not in the conditioned space should be properly insulated in order to both conserve energy and prevent condensation or moisture damage.

2. APPLICATION

This is a fan-assisted Category I forced air gas furnace for outdoor installation. A fan-assisted furnace is equipped with an integral mechanical means to draw products of combustion through the combustion chamber and heat exchanger. The furnace installation must conform with local building codes and ordinances or, in their absence, with the National Fuel Gas Code ANSI Z223.1 or CAN/CGA-B149.1, latest edition, and the National Electrical Code ANSI/NFPA-7 or CSA C22.1, latest edition. It is the personal responsibility and obligation of the purchaser to contact a qualified installer to assure that installation is adequate and is in conformance with governing codes and ordinances.

IMPORTANT NOTICE

THIS FURNACE IS NOT INTENDED FOR USE AS A CONSTRUCTION HEATER.

USE OF THIS FURNACE DURING CONSTRUCTION AND FINISHING PHASES OF A STRUCTURE IS CONSIDERED AS "OPERATION IN A CORROSIVE ATMOSPHERE" AND "UNUSUAL, NEGLIGENT OR IMPROPER USE" AND AS SUCH ARE CONSIDERED EXCLUSIONS BY THE BARD MANUFACTURING COMPANY LIMITED WARRANTY.

When a furnace is used as a construction heater, it is operated under unusual and abnormal conditions that can cause condensation to occur in the furnace and/or vent system on WAG series that will not condense under normal operation conditions when properly sized, installed and setup for operations.

Combined with condensation problems are the many sources of chloride that are present in high concentrations during construction phases of a structure. These chloride sources are either very reduced or the vapors have left once the construction activities are completed and the structure is ready to occupy.

Many of the more common construction sources of chlorides are listed below, and they are usually present in large quantities:

Cement/Concrete Mixtures	Tile /Counter Cements
Paint	Adhesives
Stain, Varnish	Cements and Glues
Solvents	Dust Particles
Wood Preservatives	Foam Insulation
Floor Sealers	

Exposure to the following substances in the combustion air supply must be avoided:

- Chlorine based swimming pool chemicals
- Water softening chemicals
- Deicing salts or chemicals
- Carbon tetrachloride
- Halogen type refrigerants
- Cleaning solvents (such as perchloroethylene)
- Printing inks, paint removers, varnishes, etc.
- Hydrochloric acid
- Cements and glues
- Masonry acid washing materials

The unit is designed for use with or without duct work. See Warning following. Flanges are provided for attaching the supply and return ducts. These instructions explain the recommended method to install the air cooled self-contained unit and the electrical wiring connections to the unit. The refrigerant system is completely assembled and charged. All internal wiring is complete.

These instructions and any instructions packaged with any separate equipment required to make up the entire air conditioning system should be carefully read before beginning the installation. Note particularly "Starting Procedure" and any tags and/or labels attached to the equipment.

WARNING

In all cases, there must be a metal duct connection made to the supply air flange, and a one inch clearance to combustibles must be maintained to this duct connection.

For free blow applications, a metal sleeve must be used in the wall opening itself, again maintaining a one inch clearance to combustibles.

Failure to use the sheet metal can cause fire resulting in property damage, injury, or death.

See Figure 1 and clearance information in Section 7 for additional information.

3. HIGH ALTITUDE APPLICATIONS

Ratings of gas utilization equipment are based on sea level operation and need not be changed for operation at elevations up to 2,000 feet. For operation at elevations above 2,000 feet and in the absence of specific recommendations from the local authority having jurisdiction, equipment ratings shall be reduced as specified in Section 18.

4. TRANSPORTATION DAMAGE

All units are packed securely in shipping container. All units should be carefully inspected upon arrival for damage. In the event of damage, the consignee should:

1. Note on delivery receipt of any damage to container.
2. Notify carrier promptly, and request an inspection.
3. In case of concealed damage, the carrier must be notified as soon as possible within 15 days after delivery.

4. Claims for any damage, apparent or concealed, should be filed with the carrier, using the following supporting documents:

- A. Original Bill of Lading, certified copy, or indemnity bond.
- B. Original paid freight bill of indemnity in lieu thereof.
- C. Original invoice or certified copy thereof showing trade and other discounts or deductions.
- D. Copy of the inspection report issued by carrier's representative at the time damage is reported to carrier.

5. INSTALLATION

Size of unit for proposed installation should be based on heat loss calculation made according to methods of Air Conditioning Contractors of America (ACCA). The air duct should be installed in accordance with the Standards of the National Fire Protection Association for the Installation of Air Conditioning and Ventilating systems of Other Than Residence Type, NFPA No. 90A, and Residence Type Warm Air Heating and Air Conditioning Systems, NFPA No. 90B. Where local regulations are at a variance with instructions, installer should adhere to local codes.

6. WALL MOUNTING

1. Two holes, the size of the supply and return air openings must be cut through the wall as detailed in Figure 1.
2. On wood-frame walls, the wall construction must be strong and rigid enough to carry the weight of the unit without transmitting any unit vibration.
3. Concrete block walls must be thoroughly inspected to insure that they are capable of carrying the weight of the installed unit.
4. Ducts through the walls must be insulated and all joints taped or sealed to prevent air or moisture entering the wall cavity.
5. Some installations may not require any return air duct. It is recommended that on this type of installation that a filter grille be located in the wall. Filters must be of sufficient size to allow a maximum velocity of 400 FPM.

WARNING

Clearances from combustible materials must be maintained as specified. Failure to maintain clearances could cause fire resulting in property damage, injury, or death.

FIGURE 1

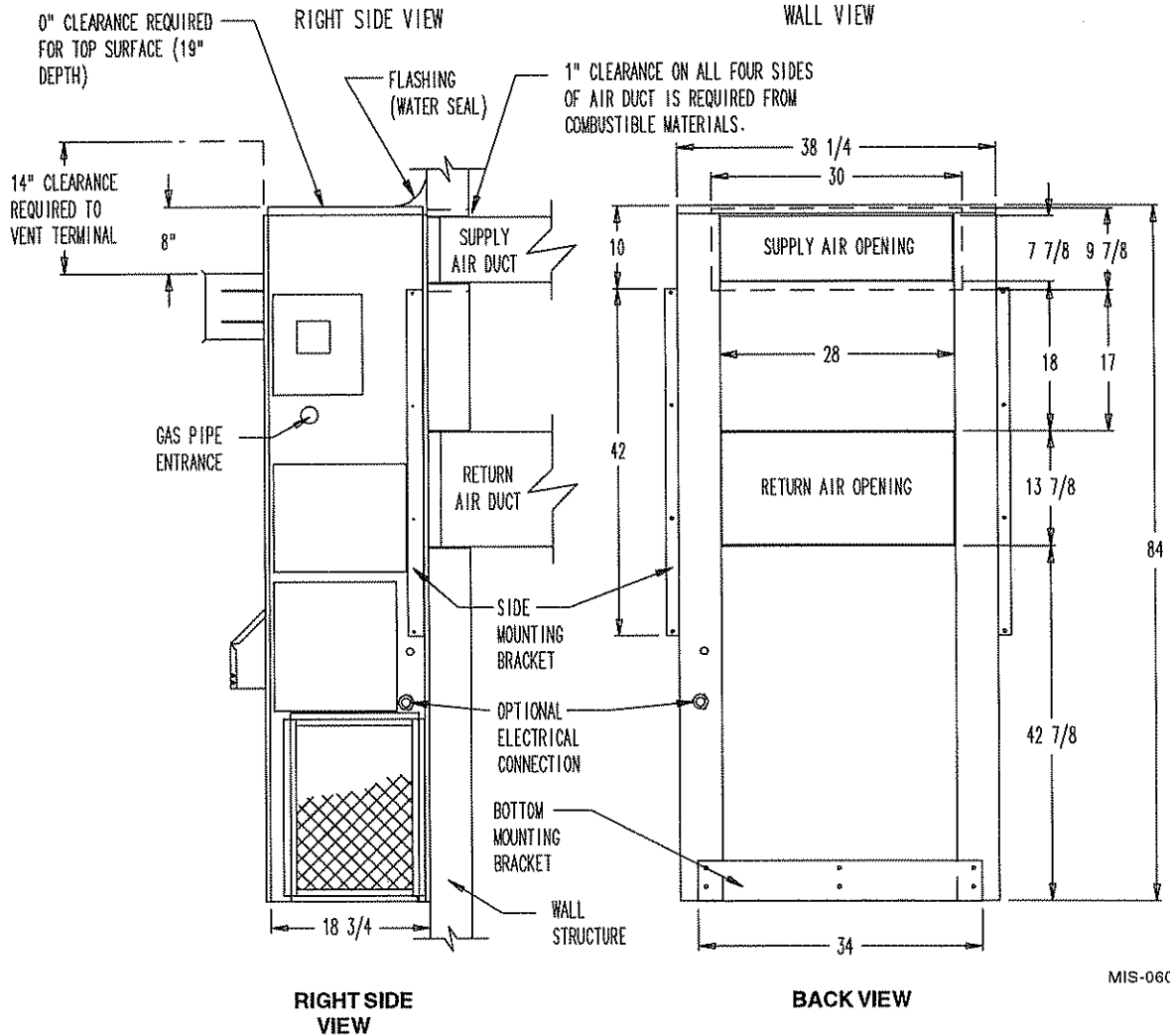

MOUNTING INSTRUCTIONS

1. These units are secured by wall mounting brackets which secure the unit to the outside wall surface at both sides and at the bottom.
2. The unit itself is suitable for "0" inch clearance, but the supply air duct flange and the first three feet of supply air duct require 1 inch clearance to combustible material. If combustible, use 30"x10" dimensions for sizing of wall opening; if noncombustible, use 28"x8" dimensions.
3. After the wall opening positions have been selected, lay out the position for the bottom and side brackets. Fasten the brackets securely to the wall (type of fasteners will depend on wall construction).
4. Be sure to observe the 10" dimension when attaching the side brackets. This will assure that no screws are driven into the unit sides damaging any internal parts. One-half inch sheet metal screws are recommended.
5. For additional mounting rigidity, the return air frame or collar can be drilled and screwed or welded to the structural wall itself.
6. Maintain 30 inches minimum clearance on right side of unit for service access and adequate condenser air flow.

FIGURE 2

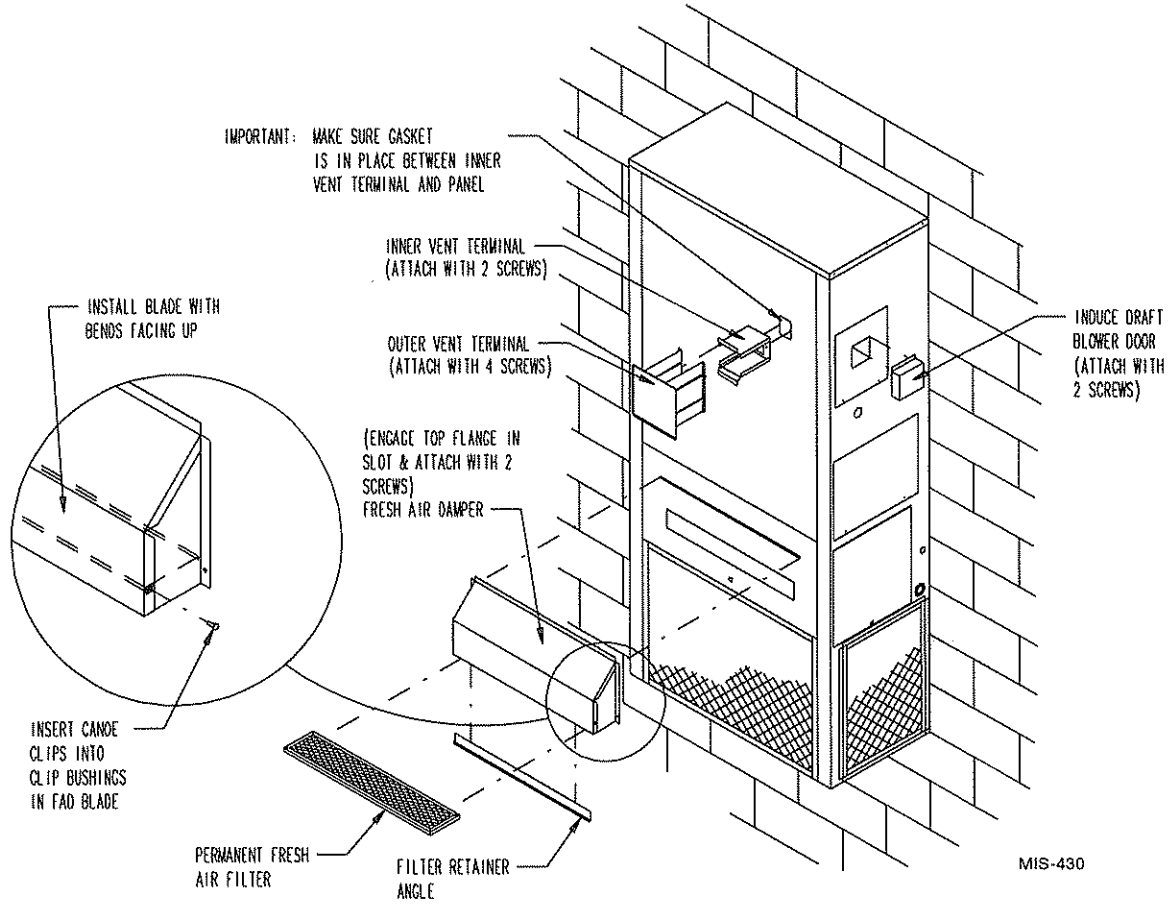
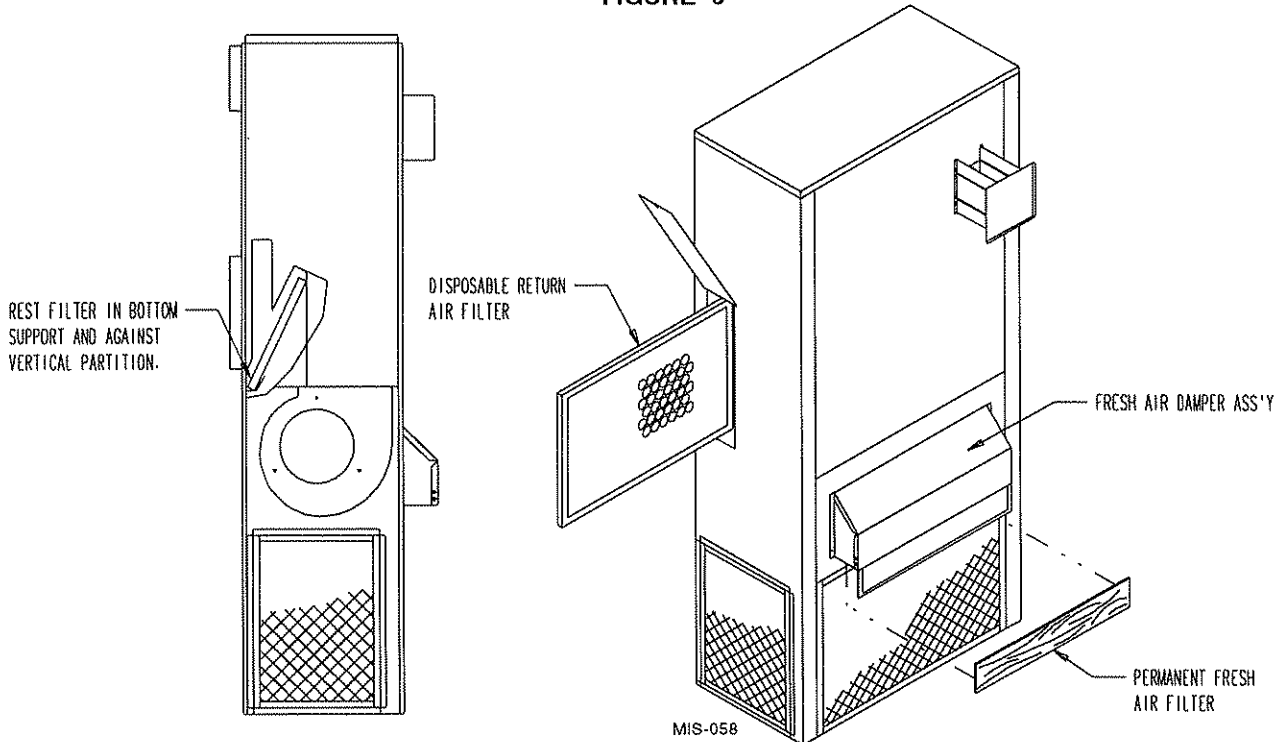

FIGURE 3



7. CLEARANCES

Minimum clearances, as specified, must be maintained from adjacent structures to provide adequate fire protection, adequate combustion air, and room for service personnel. See Figure 1 for reference.

While minimum clearances are acceptable for safety reasons, they may not allow adequate air circulation around the unit for proper operation in the cooling mode. Whenever possible, it is desirable to allow additional clearance, especially around the condenser inlet and discharge openings. **DO NOT** install the unit in a location that will permit discharged air from the condenser to recirculate to the condenser inlet.

TABLE 2

Outlet Duct (from combustible materials)	1 inch first 3 feet
Vent Terminal (from combustible materials)	14 inches
Condenser Inlet	30 inches
Filter Service	30 inches
Top (for 19 inch depth)	0 inches
Burner Service (Combustion Air Inlet)	17 inches
Combustible Base (Wood or Class A, B or C roof covering material)	0 inches

WARNING

Clearances from combustible materials must be maintained as specified. Failure to maintain clearances could cause fire resulting in property damage, injury, or death.

8. DUCT WORK

Design the duct work according to methods given by the Air Conditioning Contractors of America. When duct runs through unheated spaces, it should be insulated with a minimum of one inch of insulation. Use insulation with a vapor barrier on the outside of the insulation. Flexible joints should be used to connect the duct work to the equipment in order to keep the noise transmission to a minimum.

When a furnace is installed so that supply ducts carry air circulated by the furnace to areas outside the space containing the furnace, the return air shall also be handled by a duct(s) sealed to the furnace casing and terminating outside the space containing the furnace.

A one inch clearance to combustible material for the first three feet of duct attached to the outlet air frame is required. See Wall Mounting instructions on Page 5 for further details.

WARNING

A sheet metal sleeve connected to the supply air duct flange is required on free blow (unducted) applications and the one inch clearance from the sleeve to combustibles is required. Failure to use the sheet metal can cause fire resulting in property damage, injury, or death.

9. MOUNTING BRACKETS

Two side mounting brackets are shipped fastened to the lower back surface. A bottom support bracket is shipped in the return air chamber accessed from the back of the unit. Refer to Figure 1 for proper assembly of the mounting brackets.

10. VENT TERMINAL AND INDUCED DRAFT BLOWER HOOD

Both the vent terminal and induced draft blower hood are shipped in the return air chamber. Remove the two shipping screws and separate the two piece assembly. Remove the four screws that surround the vent discharge opening, and then install the inner vent terminal by using the same four screws just removed. Make sure gasket is in place. Slide the outer vent terminal over the inner piece and secure with four screws (two each side). See Figure 2. Also see Figure 1 for proper clearance to the vent terminal.

CAUTION

Vent terminal must be installed as shown for proper operation of the heating system.

11. VENT RESIZING INSTRUCTIONS

When an existing furnace is removed from a venting system servicing other appliances, the venting system is likely to be too large to properly vent the remaining attached appliances.

The following steps shall be followed with each of the appliances remaining connected to the common venting system, placed in operation one at a time while the other appliances remaining connected to the common venting system are not in operation.

1. Seal any unused openings in the venting system;
2. Inspect the venting system for proper size and horizontal pitch, as required in the National Fuel Gas code, ANSI Z223.1 or the CAN/CGA B149

Installation Codes and these instructions. Determine that there is no blockage or restriction, leakage, corrosion and other deficiencies which could cause an unsafe condition;

3. In so far as is practical, close all building doors and windows and all doors between the space in which the appliance(s) connected to the venting system are located and other spaces of the building. Turn on clothes dryers and any appliances not connected to the venting system. Turn on any exhaust fans, such as range hoods and bathroom exhausts, so they will operate at maximum speed. Do not operate a summer exhaust fan. Close fireplace dampers;
4. Follow the lighting instructions. Place the appliance being inspected in operation. Adjust thermostat so appliance shall operate continuously;
5. Test for draft hood equipped appliance spillage at the draft hood relief opening after 5 minutes of main burner operation. Use the flame of a match or candle;
6. After it has been determined that each appliance connected to the venting system properly vents when tested as outlined above, return doors, windows, exhaust fans, fireplace dampers and any other gas-burning appliances to their previous conditions of use;
7. If improper venting is observed during any of the above tests, the venting system must be corrected.

12. FRESH AIR DAMPER ASSEMBLY

The fresh air damper assembly is shipped in the return air chamber accessed from the back of the unit. Remove the shipping screws and damper assembly. Attach the damper assembly to the blower service door as shown in Figure 2. The damper assembly includes a permanent filter that can be easily removed for cleaning. See Figure 3.

For shipping purposes the damper blade and damper filter are located behind the return air filter taped to the back of the unit. The damper blade is installed into the damper housing by means of two canoe clips (one in each end) as shown in Figure 2. Figure 3-A shows four different blade positions. Depending upon the fresh air requirements, install one canoe clip on each end to restrict the blade to the position desired.

All capacity, efficiency and cost of operation information as required for Department of Energy "Energyguide" Fact Sheets is based upon the fresh air blank-off plate (BOP-A)

in place and is recommended for maximum energy efficiency. The blank-off plate is available upon request from the factory and is installed in place of the fresh air damper shipped with each unit

13. WIRING

WARNING

For your personal safety, turn off electric power at service entrance panel before making any electrical connections. Failure to do so could result in electric shock or fire.

ELECTRICAL POWER SUPPLY

Run a separate circuit from a separate fuse or circuit breaker in the service entrance panel with an ampacity rating per Serial Plate and Table 1. Locate a shutoff switch at the furnace. Make connections from this switch to the furnace control panel as shown in the furnace wiring diagram.

FIGURE 3-A

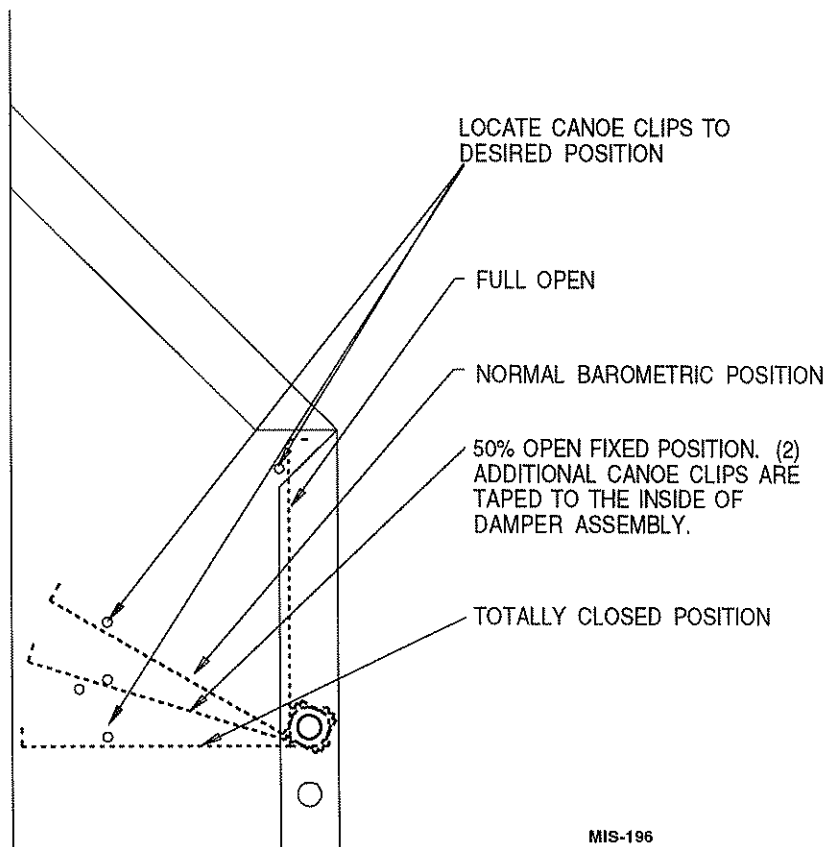

WARNING

Failure to provide an electrical power supply shutoff means could result in electric shock or fire.

ELECTRICAL GROUNDING

When installed, the furnace must be electrically grounded in accordance with local codes or in the absence of local codes, with the National Electrical Code, ANSI/NFPA 70, or Canadian Electrical Code, CSA22.1, latest edition. Use a #14 AWG copper wire from green ground wire on the furnace to a grounded connection in the service panel or a properly driven and electrically grounded ground rod.

WARNING

Failure to provide a proper electrical ground could result in electric shock or fire.

FIELD INSTALLED EQUIPMENT

Wiring to be done in the field between the furnace and devices not attached to the furnace, or between separate devices which are field installed and located, shall conform with the temperature limitation for Type T wire {63 degrees F rise (36 degrees C)} when installed in accordance with the manufacturer's instructions.

WIRING – LOW VOLTAGE WIRING

230-208, 1 phase and 3 phase equipment dual primary voltage transformers. All equipment leaves the factory wired on 240V tap. For 208V operation reconnect from 240V to 208V tap. The acceptable operating voltage range for the 240 and 208V taps are:

**TABLE 3
OPERATING VOLTAGE RANGE**

TAP	RANGE
240V	253 - 216
208V	220 - 187

4. THERMOSTAT

Install the thermostat in accordance with instructions packed with it. Locate the thermostat 4-1/3 feet from the floor on an inside wall away from drafts, warm air registers, and floor or table lamps. Refer to unit wiring diagrams for connections.

All 24V wall thermostats have heat anticipators to compensate the thermostat for various system controls and allow the best possible cycle rates. Some anticipators are fixed and require no adjustment. However, the majority of wall thermostats have adjustable anticipators and do require adjustment to match the current rating of the control system. The nominal setting should be .20, but each installation should be checked for best operation.

Failure to adjust the anticipator lever to correspond to the actual current draw through the thermostat will cause severe short cycling if set too low and room temperature may never attain the thermostat set point; and if set too high, will cause room temperature to overshoot the set point.

Five (5) wires should be run from thermostat subbase to the 24V terminal board in the unit. A four conductor, 18 gauge copper, color-coded thermostat cable is recommended.

**TABLE 4
THERMOSTAT WIRE SIZE**

Transformer VA	FLA	Gauge	Maximum Distance in Feet
55	23	20 gauge	45
		18 gauge	60
		16 gauge	100
		14 gauge	160
		12 gauge	250

15. GAS SUPPLY AND PIPING

GENERAL RECOMMENDATIONS

1. Be sure the gas line complies with the local codes and ordinances, or in their absence with the National Fuel Gas Code, ANSI Z223.1, or Natural Gas Installation Code, CAN/CGA B149.1, or Propane Installation Code B149.2, latest edition.
2. A sediment trap or drip leg must be installed in the supply line to the furnace.
3. A ground joint union shall be installed in the gas line adjacent to and upstream from the gas valve and downstream from the manual shutoff valve.
4. An 1/8" NPT plugged tapping accessible for test gauge connection shall be installed immediately upstream of

the gas supply connection to the furnace for the purpose of determining the supply gas pressure. This can be omitted if local codes permit use of plugged tapping in gas valve inlet.

5. Install listed manual shutoff valve in the supply gas line external to and immediately upstream of the furnace. See Figure 4.
6. Use steel or wrought iron pipe and fittings.
7. **DO NOT** thread pipe too far. Valve distortion or malfunction may result from excess pipe within the control. Use pipe joint compound resistant to the action of liquefied petroleum gases on male threads only. **DO NOT** use Teflon tape. See Table 5 and Figure 5.

FIGURE 4

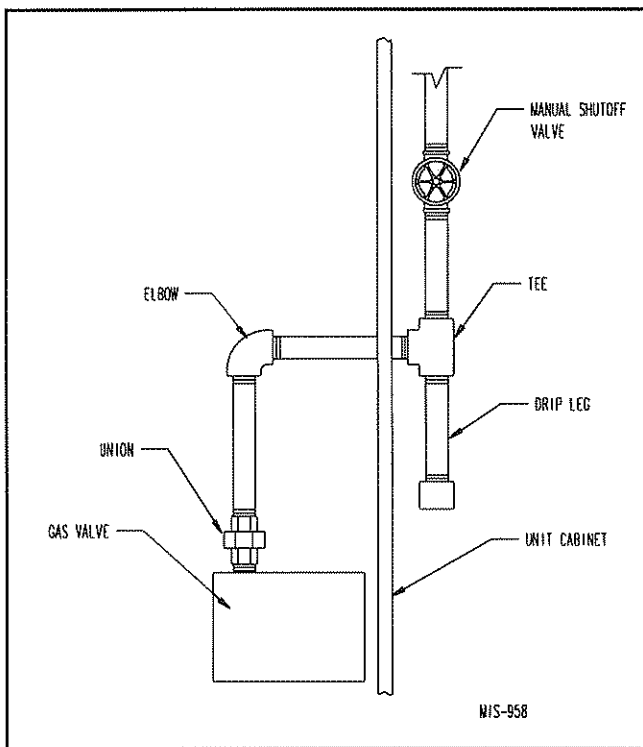
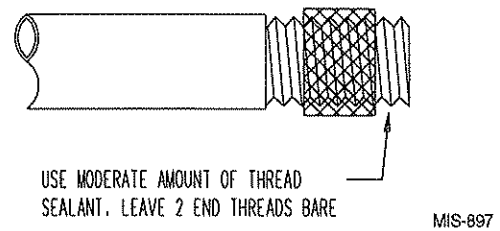

TABLE 5 - LENGTH OF STANDARD PIPE THREADS (Inches)

Pipe Size	Effective Length of Thread	Overall Length of Thread
3/8	1/2	9/16
3/4	1/2 9/16	13/16
1	9/16	1

FIGURE 5

PROPER PIPING PRACTICE



8. Refer to Table 6 for Gas Pipe Sizes for natural gas. If more than one appliance is supplied from a single line size, capacity must equal or exceed the combined input to all appliances, and the branch lines feeding the individual appliances properly sized for each input.

TABLE 6 – GAS PIPE SIZES - NATURAL GAS

Length of Pipe - Feet	Pipe Capacity – BTU Per Hour Input Pipe Size			
	1/2"	3/4"	1"	1-1/4"
10	132,000	278,000	520,000	1,050,000
20	92,000	190,000	350,000	730,000
30	73,000	152,000	285,000	590,000
40	63,000	130,000	245,000	500,000
50	56,000	115,000	215,000	440,000
60	50,000	105,000	195,000	400,000
70	46,000	96,000	180,000	370,000
80	43,000	90,000	170,000	350,000
100	38,000	79,000	150,000	305,000

CHECKING THE GAS PIPING

Before turning gas under pressure into piping, all openings from which gas can escape should be closed. Immediately after turning on gas, the system should be checked for leaks. This can be done by watching the 1/2 cubic foot test dial and allowing 4 minutes to show any movement, and by soaping each pipe connection and watching for bubbles. If a leak is found, make the necessary repairs immediately and repeat the above test. The furnace must be isolated from the gas supply piping system by closing the manual shutoff valve on the combination gas control valve during pressure testing of the gas supply piping system at pressures up to 1/2 PSIG. The furnace and its individual shutoff valve must be disconnected from supply piping and supply piping capped during any pressure testing of supply piping system at test pressures in excess of 1/2 PSIG.

Defective pipes or fittings should be replaced and not repaired. Never use a flame or fire in any form to locate gas leaks; use a soap solution.

After the piping and meter have been checked completely, purge the system of air. *DO NOT* bleed air inside the furnace. Be sure to check and relight all the gas pilots on other appliances that may have been extinguished because of interrupted gas supply.

16. MANIFOLD PRESSURE ADJUSTMENT

You will need a 0 to 15 inch water manometer with 0.1 inch resolution and a 1/8" NPT manual shutoff valve to measure actual manifold pressure.

WARNING

Correct manifold pressure is necessary for proper ignition and burner operation. Failure to accurately adjust pressure could cause heat exchanger failure.

1. Turn off gas at equipment shutoff valve in gas supply line just ahead of furnace.
2. Remove plug from outlet pressure tap in gas control.
3. Install 1/8" NPT manual shutoff valve in hole vacated by plug. Make sure shutoff valve is in off position.
4. Attach manometer to 1/8" NPT manual shutoff valve just installed.
5. Slowly open equipment shutoff valve in gas supply line just ahead of furnace. Start furnace following "Operating Instructions" on front door.
6. Slowly open 1/8" NPT manual shutoff valve leading to manometer.
7. Read manifold pressure on manometer.
8. Adjust manifold pressure by turning gas control regulator adjusting screw clockwise to increase pressure or turning counterclockwise to decrease pressure. Manifold pressure must be within allowable range below:
 - Natural gas manifold pressure must be between 3.2 and 3.8 inches W.C.

NOTE: For natural gas, if gas flow rate can't be properly set within these pressure ranges then you must change main burner orifices to obtain proper gas flow rate.

9. Shut off furnace. Turn off gas at equipment shutoff valve in gas supply line just ahead of furnace. Install outlet pressure tap plug in gas control. Turn on gas.
10. Check regulator adjustment cover screw and gas control plug for gas leaks. Use a commercial soap solution made for leak detection.

17. CHECKING GAS INPUT RATE

It is the installer's responsibility to see that the Btu input rate of the furnace is properly adjusted. Under-firing could cause inadequate heat, excessive condensation or ignition problems. Overfiring could cause sooting, flame impingement or overheating of heat exchanger.

WARNING

Failure to adjust furnace to the proper firing rate could cause heat exchanger failure.

Depending on your local gas heating value and elevation, you may need to adjust manifold pressure or change orifices to get proper gas input rate. Check with your local gas supplier to determine heating value (Btu/cu. ft.) of natural gas in your area.

NOTE: If furnace is being installed at an altitude of more than 2000 feet above sea level, you must derate the furnace. See Section 18 "Standard Orifice Sizing and High Altitude Derate".

NATURAL GAS INPUT RATE

Natural gas heating value (Btu/cu. ft.) can vary significantly. Before starting natural gas input check, obtain gas heating value at your location from local supplier. You will need a stopwatch to measure actual gas input.

1. Gas supply pressure must be between 5 and 7 inches W.C. for natural gas.
2. Turn off all other gas appliances. You may leave pilots on.
3. Start furnace following "Operating Instructions" on front door.
4. Let furnace warm up for 6 minutes.
5. Locate gas meter. Determine which dial has the least cubic feet of gas and how many cubic feet per revolution it represents. This is usually one-half, one or two cubic feet per revolution.

6. With stopwatch, measure time it takes to consume two cubic feet of gas.
 - If dial is one-half cubic foot per revolution, measure time for four revolutions.
 - If dial is one cubic foot per revolution, measure time for two revolutions.
 - If dial is two cubic feet per revolution, measure time for one revolution.
7. Divide this time by two. This gives average time for one cubic foot of gas to flow through meter. Example: If it took 58 seconds for two cubic feet to flow, it would take 29 seconds for one cubic foot to flow.
8. Calculate gas input using this formula:

$$\text{Gas input} = \frac{\text{Gas Heating Value (Btu/cu. ft.)} \times 3,600 \text{ sec/hr}}{\text{Time (Seconds for one cubic foot of gas)}} = \text{Btu/hour}$$

Example:

Assume it took 29 seconds for one cubic foot of gas to flow and heating value of 1,000 Btu/cu. ft.

$$\text{Gas input} = \frac{1,000 \times 3,600}{29} = 124,138 \text{ Btu}$$

If you left no other pilots on, this is the furnace gas input.

9. If you left water heater, dryer or range pilots on, allow for them in calculating correct furnace gas input. A quick way is to allow 1,000 Btu per hour for a water heater, 500 Btu per hour for dryer and 500 Btu per hour for each range burner pilot.

Example:

If you left gas water heater, dryer, two range burner pilots and one oven pilot on, allow:

Water heater pilot	1,000 Btu per hour
Dryer pilot	500 Btu per hour
2 range burner pilots	1,000 Btu per hour
1 range oven pilot	500 Btu per hour
	3,000 Btu per hour

Subtracting 3,000 Btu per hour from 124,138 Btu per hour measured above equals 121,138 Btu per hour. This would be the correct furnace gas input after allowing for pilots left on.

10. Manifold pressure may be adjusted within the range of 3.2 inches W.C. to 3.8 inches W.C. to get rated input ± 2 percent. See Section 17, "Manifold Pressure Adjustment". If you cannot get rated input with manifold pressure within the allowable range, you must change orifices.

PROPANE (LP) GAS INPUT RATE

WARNING

Propane (LP) gas installations do not have gas meters to double check input rate. Measure manifold pressure adjustment with an accurate manometer. Failure to accurately adjust pressure could cause heat exchanger failure, asphyxiation, fire or explosion, resulting in damage, injury or death.

1. Make sure you have proper main burner orifices.
2. Gas supply pressure must be between 11 and 13 inches W.C. for propane (LP) gas.
3. Start furnace following "Operating Instructions" on front door.
4. Let furnace warm up for 6 minutes.
5. Adjust manifold pressure to 10.0 W.C. ± 0.3 inches W.C. See Section 16, "Manifold Pressure Adjustment".

WARNING

Do not set Propane (LP) manifold pressure at 11.0 inches W.C. It could cause heat exchanger failure.

18. STANDARD ORIFICE SIZING AND HIGH ALTITUDE DERATE

This furnace is shipped with fixed gas orifices for use with Natural Gas and sized for 1000 Btu/cubic foot gas. The furnace is dual rated with 65,000 and 55,000 Btu input ratings. It is shipped from factory with orifices for 65,000 Btu input installed, and 55,000 Btu input orifices packaged and located in burner compartment. Make sure actual gas input does not exceed rating plate input. You may need to change orifices to get correct gas input. Whether you do or not depends on input, and your gas heat value at standard conditions and elevation. Consult your local gas supplier for gas heat value and any special derating requirements. See Section 19 for more information.

At higher altitudes, the density of the air is reduced. Therefore, for proper combustion, the quantity of gas burned in the furnace must also be reduced. This is called derating. Furnaces must be derated when installed at altitudes greater than 2,000 feet above sea level.

At elevations above 2,000 feet the furnace must be derated. It is the installer's responsibility to see that the furnace input rate is adjusted properly. Derating must be achieved by reducing the size of the main burner orifices. Derating the furnace by adjusting the manifold pressure lower than the range specified in the Section 16, "Manifold Pressure Adjustment" is considered to be an improper procedure.

U. S. INSTALLATIONS ONLY

Ratings of gas utilization equipment are based on sea level operation and need not be changed for operation at elevations up to 2,000 feet. For operation at elevations above 2,000 feet, and in the absence of specific recommendations from the local authority having jurisdiction, equipment ratings shall be reduced at the rate

of 4 percent per each 1,000 feet above sea level before selecting appropriately sized equipment. (Ref. ANSI Z223.1 - latest edition, Par. 8.12). See Table 7 for high altitude derate information, and for fuel gas Btu ratings from 800-1100 BTU per cubic foot.

TABLE 7

65,000 BTU INPUT — U.S. INSTALLATIONS ONLY										
Gas Type	Gas BTU Content	ELEVATION, FEET ABOVE SEA LEVEL								
		0-2000	3000	4000	5000	6000	7000	8000	9000	10000
Natural	800	3.00	2.90	33.	34	2.80	2.75	36	37	38
Natural	825	32	33.	34.	2.80	2.75	36	37	2.60	39
Natural	850	32	34	2.80	2.75	36	37	2.60	39	2.50
Natural	875	2.90	2.80	2.75	36	37	2.60	38	39	2.45
Natural	900	34	2.75	36	37	37	2.60	39	40	41
Natural	925	34	36	37	37	2.60	39	2.50	2.45	2.40
Natural	950	7/64	37	37	2.60	39	39	2.45	2.40	42
Natural	975	2.75	37	2.60	38	39	2.50	2.45	2.40	2.30
Natural	1000	36*	2.60	38	39	2.50	2.45	2.40	2.35	2.30
Natural	1025	37	38	39	2.50	2.45	2.40	3/32	2.30	43
Natural	1050	37	39	39	40	2.45	2.40	2.35	2.30	43
Natural	1075	2.60	39	40	2.45	2.40	42	2.30	43	2.20
Natural	1100	38	2.50	2.45	2.40	3/32	2.35	2.30	2.25	2.20
Propane	2500	1.65	1.60	1/16	1.55	53	53	1.45	1.45	1.40

55,000 BTU INPUT — U.S. INSTALLATIONS ONLY										
Gas Type	Gas BTU Content	ELEVATION, FEET ABOVE SEA LEVEL								
		0-2000	3000	4000	5000	6000	7000	8000	9000	10000
Natural	800	7/64	37	37	2.60	39	39	2.45	2.40	42
Natural	825	2.75	37	2.60	38	39	40	41	3/32	2.30
Natural	850	36	2.60	38	39	40	2.45	2.40	2.35	2.30
Natural	875	37	39	39	2.50	2.45	2.40	42	2.30	43
Natural	900	2.60	39	2.50	2.45	2.40	3/32	2.30	43	2.20
Natural	925	38	2.50	2.45	2.40	3/32	2.35	2.30	43	2.20
Natural	950	39	2.45	41	2.40	2.35	2.30	43	2.20	2.15
Natural	975	39	41	2.40	2.35	2.30	43	2.25	2.20	2.15
Natural	1000	40**	2.40	42	2.30	2.30	43	2.20	2.15	2.10
Natural	1025	2.45	3/32	2.30	2.30	43	2.20	44	2.15	2.10
Natural	1050	41	2.35	2.30	43	2.25	2.20	2.15	2.10	46
Natural	1075	2.40	2.30	43	2.25	2.20	44	2.10	45	2.05
Natural	1100	3/32	2.30	43	2.20	44	2.15	2.10	46	2.00
Propane	2500	53	1.45	1.45	1.40	1.40	1.35	1.35	55	1.30

NOTE: Two digit numbers are Number Drills; example 44
 Three digit numbers with two decimal places are Metric Drills; example 2.30mm
 Numbers shown as fractions are Fractional Drills; example 5/64

* Factory installed orifices

** Orifices are shipped with unit, not installed. See Section 19

Canada Installations Only

Rating of gas utilization equipment is based on sea level operation and need not be changed for operation at elevations up to 2000 feet. For operation at elevations from 2001 to 4500 feet a main burner orifice change is required in accordance with CAN/CGA-2.17-M91

Standard for Gas-Fired Appliances for Use at High Altitudes. See Table 8 for 2001-4500 feet altitude derate information, and for fuel gas Btu ratings from 800-1100 Btu per cubic foot.

TABLE 8

65,000 BTU INPUT				55,000 BTU INPUT			
Gas Type	Gas BTU Content	ELEVATION		Gas Type	Gas BTU Content	ELEVATION	
		0-2000	2001-4500			0-2000	2001-4500
Natural	800	3.00	2.90	Natural	800	7/64	37
Natural	825	32	33	Natural	825	2.75	2.60
Natural	850	32	34	Natural	850	36	39
Natural	875	2.90	35	Natural	875	37	39
Natural	900	34	2.75	Natural	900	2.60	2.50
Natural	925	34	36	Natural	925	38	2.45
Natural	950	7/64	37	Natural	950	39	2.40
Natural	975	2.75	37	Natural	975	39	2.40
Natural	1000	36*	2.60	Natural	1000	40**	2.35
Natural	1025	37	38	Natural	1025	2.45	2.30
Natural	1050	37	39	Natural	1050	41	2.30
Natural	1075	2.60	2.50	Natural	1075	2.40	43
Natural	1100	38	40	Natural	1100	3/32	43
Propane	2500	1.65	1.60	Propane	2500	53	1.45

NOTE: Two digit numbers are Number Drills; example 44
 Three digit numbers with two decimal places are Metric Drills; example 2.30mm
 Numbers shown as fractions are Fractional Drills; example 5/64
 * Factory installed orifices
 ** Orifices are shipped with unit, not installed. See Section 19

19. CONVERSION OF GAS INPUT BTUH FROM HIGH TO LOW RATING

All WAG series units are produced with maximum Btuh input (65,000 Btuh) orifices installed. To field convert to 55,000 Btuh input, a change to main burner orifices is required.

NOTE: No change to air orifices is necessary. A set of low input orifices is shipped with every unit. They will be found packaged in a bag behind the burner door. Refer to the unit rating plate to confirm the proper orifice size. Proper installation of the orifices is detailed as follows:

- A. Shut off electrical supply to the unit.
- B. Shut off gas supply to the unit.
- C. Remove burner access panel.
- D. Disconnect gas valve from gas supply piping.
- E. Disconnect the two plugs from the gas valve.

- F. Remove screw securing pilot assembly to burner bracket and then remove the four screws securing the manifold to the burner brackets.
- G. Remove the manifold assembly so that orifices are now accessible and remove orifices.
- H. Apply a modest amount of pipe compound to the new orifices and screw them into the manifold.
- I. To assemble burner reverse steps A through F.

 WARNING
Failure to follow these instructions could create a hazard resulting in property damage, bodily injury, or death.

20. MEASURING AIR TEMPERATURE RISE

Air temperature rise (supply air temperature minus return air temperature) must be within allowable air temperature rise range specified on furnace rating plate and in Table 1.

You will need 2 thermometers with 1 degree resolution capable of reading up to 200 degrees F. Check thermometers to make sure they agree, or compensate accordingly.

Follow this procedure:

1. Open supply air registers and return air grilles. Make sure the registers and grilles are free of obstruction from rugs, carpets, drapes or furniture.
2. Set balancing dampers in supply duct system.
3. Check duct work for obstructions or leaks.
4. Make sure filters are clean and in place.
5. Place one thermometer in supply air plenum approximately 2 feet from furnace. Locate thermometer tip in center of plenum to ensure proper temperature measurement.
6. Place second thermometer in return air duct approximately 2 feet from furnace. Locate thermometer tip in center of duct to ensure proper temperature measurement.
7. Set room thermostat on highest temperature setting. Operate furnace 10 minutes. Record supply air and return air temperatures.
8. Calculate air temperature rise by subtracting return air temperature from supply air temperature.
 - If air temperature rise is above the temperature rise range on rating plate, furnace is overfired or has insufficient airflow. Check gas input following the instructions in Section 17, "Checking Gas Input Rate". If air temperature rise is still above temperature rise range specified, more heating air flow is needed. Check duct work and grilles to make sure all are properly sized.
 - If air temperature rise is below the temperature rise range on rating plate, furnace is underfired or has too much airflow. Check gas input following the instructions in Section 17, "Checking Gas Input Rate". If air temperature rise is still below temperature rise range specified, less heating air flow is needed. Adjust dampers or grilles as needed.
 - After making adjustments, you must check air temperature rise to verify that resulting air temperature rise is within allowable range. If air temperature rise is still outside the temperature rise range specified on rating plate, check duct system design with a qualified heating engineer. It may be necessary to re-size the duct work. Recheck air temperature rise after revising duct systems.

9. Set room thermostat to desired setting.

10. Remove thermometers and seal duct work holes.

NOTE: Failure to seal holes could result in reduced system performance.

21. FILTERS

A 20 x 30 x 1 throwaway filter is supplied with each unit taped to the back of the unit. This filter is installed by removing the filter service door located on the left side and sliding the filter into position as shown in Figure 3.

There is also an 8 x 26 x 1/2 washable filter that is a part of Fresh Air Damper (FAD) assembly. This filter cleans the outside air being introduced through the FAD.

Replacement filters are available through your dealer.

22. OPTIONAL COMPRESSOR CONTROL MODULE (STANDARD EQUIPMENT CANADIAN UNITS ONLY)

The compressor control is an anti-short cycle/lockout timer with high and low pressure switch monitoring and alarm relay output.

ADJUSTABLE DELAY ON MAKE AND BREAK TIMER

On a call for compressor operation the *delay on make* period begins which will be 10% of the *delay on break* setting. When the delay on make is complete and the high pressure switch (and low pressure switch if employed) is closed, the compressor contactor is energized. Upon shutdown the delay on break timer starts and prevents restart until the delay on break and delay on make periods have expired.

HIGH PRESSURE SWITCH AND LOCKOUT SEQUENCE

If the high pressure switch opens, the compressor contactor will de-energize immediately. The lockout timer will go into a *soft lockout* and stay in soft lockout until the high pressure switch closes **and** the delay on make time has expired. If the high pressure switch opens again in this same operating cycle the unit will go into *manual lockout* condition and the alarm relay circuit will energize. Recycling the wall thermostat resets the manual lockout.

LOW PRESSURE SWITCH, BYPASS, AND LOCKOUT SEQUENCE

If the low pressure switch opens for more than 120 seconds, the compressor contactor will de-energize and go into a soft lockout. Regardless the state of the low pressure switch, the contactor will reenergize after the delay on make time delay has expired. If the low pressure switch remains open or opens again for longer than 120 seconds the unit will go into manual lockout condition and the alarm relay circuit will energize. Recycling the wall thermostat resets the manual lockout.

ALARM RELAY OUTPUT

Alarm terminal is output connection for applications where alarm relay is employed. This terminal is powered whenever compressor is locked out due to HPC or LPC sequences as described.

NOTE: Both high and low pressure switch controls are inherently automatic reset devices. The high pressure switch and low pressure switch cut out and cut in settings are fixed by specific air conditioner or heat pump unit model. The lockout features, both soft and manual, are a function of the Compressor Control Module.

ADJUSTMENTS

ADJUSTABLE DELAY ON MAKE AND DELAY ON BREAK TIMER

The potentiometer is used to select Delay on Break time from 30 seconds to 5 minutes. Delay on Make (DOM) timing on power-up and after power interruptions is equal to 2 minutes plus 10% of Delay on Break (DOB) setting:

0.5 minute (30 seconds)	DOB = 123 second	DOM
1.0 minute (60 seconds)	DOB = 126 second	DOM
2.0 minute (120 seconds)	DOB = 132 second	DOM
3.0 minute (160 seconds)	DOB = 138 second	DOM
4.0 minute (240 seconds)	DOB = 144 second	DOM
5.0 minute (300 seconds)	DOB = 150 second	DOM

23. LIGHTING AND SHUTDOWN INSTRUCTIONS

FIGURE 6

FOR YOUR SAFETY READ BEFORE OPERATING

WARNING: If you do not follow these instructions exactly, a fire or explosion may result causing property damage, personal injury or loss of life.

- A. This appliance is equipped with a ignition device which automatically lights the pilot. Do not try to light the pilot by hand.
- B. **BEFORE OPERATING** smell all around the appliance area for gas. Be sure to smell next to the floor because some gas is heavier than air and will settle on the floor.
- WHAT TO DO IF YOU SMELL GAS**
- Do not try to light any appliance.
 - Do not touch any electric switch; do not use any phone in your building.
 - Immediately call your gas supplier from a neighbor's phone. Follow the gas supplier's instructions.
- If you cannot reach your gas supplier, call the fire department.
- C. Use only your hand to turn off the gas control. Never use tools. If the switch cannot be switched by hand, don't try to repair it, call a qualified service technician. Force or attempted repair may result in a fire or explosion.
- D. Do not use this appliance if any part has been under water. Immediately call a qualified service technician to inspect the appliance and to replace any part of the control system and any gas control which has been under water.

OPERATING INSTRUCTIONS

1. **STOP!** Read the safety information above on this label.
2. Set the thermostat to lowest setting.
3. Turn off all electric power to the appliance.
4. This appliance is equipped with an ignition device which automatically lights the pilot. Do not try to light the pilot by hand.
5. Remove control access panel.
6. Switch the gas control to the "OFF" position.
7. Wait five (5) minutes to clear out any gas. Then smell for gas, including near the floor. If you smell gas, **STOP!** Follow "B" in the safety information above on this label. If you don't smell, gas go to the next step.
8. Switch the gas control to the "ON" position.
9. Replace control access panel.
10. Turn on all electric power to the appliance.
11. Set thermostat to desired setting.
12. If the appliance will not operate, follow the instructions "To Turn Off Gas To Appliance" and call your service technician or gas supplier.

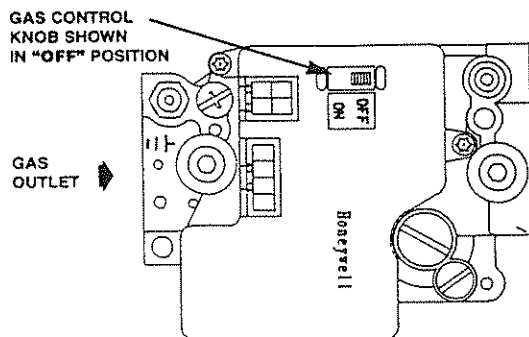

TO TURN OFF GAS TO APPLIANCE

1. Set the thermostat to lowest setting.
2. Turn off all electric power to the appliance if service is to be performed.
3. Remove control access panel.
4. Switch the gas control to the "OFF" position. Do not force.
5. Replace control access panel.

7961-543

24. SERVICE AGENCY PROCEDURES

CAUTION

Label all wires prior to disconnection when servicing controls. Wiring errors can cause improper and dangerous operation. Verify proper operation after servicing.

WARNING

Follow these procedures before inspecting furnace.

- Turn room thermostat to its lowest or off setting.
- Turn off manual gas shutoff valve.
- Wait at least 5 minutes for furnace to cool if it was recently operating.
- Turn off furnace electrical power; failure to do so could result in injury or death.

PILOT BURNER

The pilot flame can be adjusted by removing the pilot adjustment cover screw. Turn inner adjustment screw clockwise to decrease and counterclockwise to increase pilot flame. See Figure 7. Be sure to replace cover screw after adjustment to prevent possible gas leakage.

FIGURE 7- INTERMITTENT PILOT

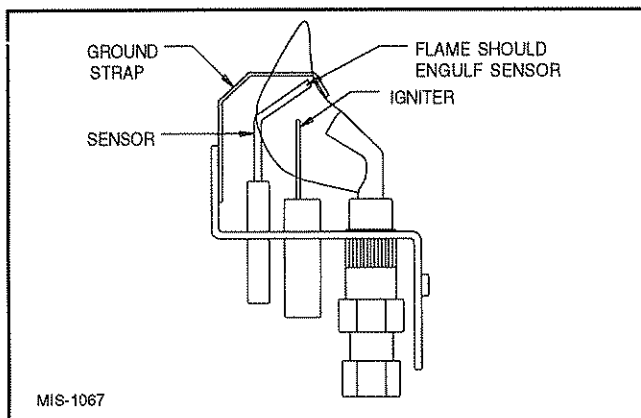

MIS-1067

MAIN BURNER

Observe the main burners in operation. The flame should be mostly "blue" with possibly a little orange (not yellow) at the tips of the flame. The flames should be in the center of the heat exchanger compartments and not impinging on the heat exchanger surfaces themselves.

The inner cone of the flame as shown in Figure 8 should be approximately 1 inch to 1-1/4 inches tall from the burner ports when natural gas is used. When propane

gas is used, the inner cones should be approximately 1/2 inch tall from the burner ports. If no primary air adjustment has been made after the furnace has been converted for use with propane gas, the inner cones may be lying flat on the burner ports. This condition can be corrected by decreasing the amount of primary air in the burners. Slowly close down the primary air shutters at the end of each burner until the desired inner cone height is obtained. Be sure to tighten all the air shutter set screws once the adjustment has been made.

The air shutters are factory adjusted completely open for use with natural gas. If flashback occurs, the air shutters may be closed slightly to prevent the flashback. If converted to propane gas, the air shutters must be adjusted as specified above.

Observe the fire until the blower starts (there is a normal delay period until the heat exchanger warms up). There should be no change in the size or shape of the flame. If there is any wavering or blowing of the flame on blower start-up, it is an indication of a possible leak in the heat exchanger.

FIGURE 8

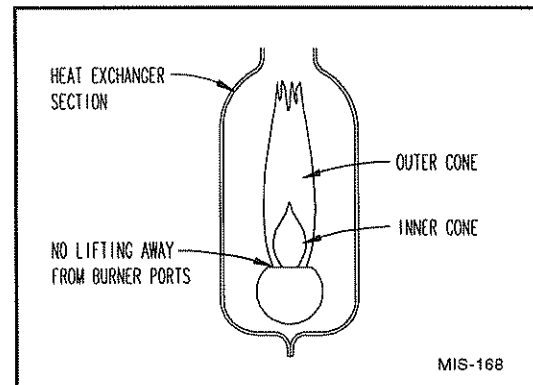
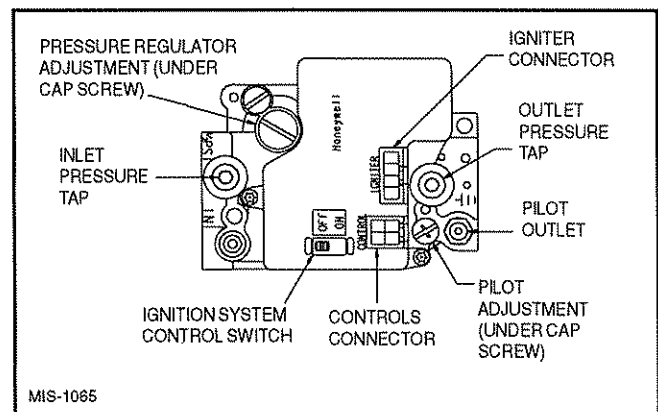

FIGURE 9 - TOP VIEW OF GAS CONTROL



BURNERS / HEAT EXCHANGER / FLUE GAS PASSAGE WAYS

The burners, heat exchanger and interior flue gas passages may be inspected using a light or small mirror or an extension handle. Remove the screw securing the flue transition to the inducer assembly. Remove the inducer and collector box and flue gas baffles. Now inspect the upper chamber of the heat exchanger.

Check the exterior of the heat exchanger and the interior flue gas passages for any evidence of deterioration due to corrosion, cracking or other causes. If signs of sealing or sooting exist, remove the burners and clean the heat exchanger, as required.

INSPECTION AND CLEANING OF BURNERS AND HEAT EXCHANGERS

1. Shut off all electricity and gas supply to the unit.
2. Remove the vent assembly and flue collector assembly.
3. Disconnect gas pipe at union.
4. Disconnect plugs from gas valve.
5. Remove screws that secure the gas manifold and remove gas valve, manifold and burners as an assembly.
6. Clean the burners with a brush and by holding the burner vertically and tapping it against a wood block. Severe cases of lint clogging may require washing the burners in hot water.
7. Clean flue gas passages by using small brushes and a vacuum cleaner. It may be necessary to fabricate handle extensions for the brushes to reach the areas that require cleaning. Reinspect after cleaning and replace the heat exchanger if defective.
8. Reinstall parts in reverse order.
9. Turn gas on and check for leaks.
10. Install all access panels, turn power on and check for normal operation.

25. MAINTENANCE INSTRUCTIONS

The unit should be inspected annually by a qualified service agency.

Routine inspection and maintenance procedures are the responsibility of the user and are outlined below.

ROUTINE MAINTENANCE

1. Air Filters – Check the condition at least monthly when the unit is in use, and replace (throwaway, fiberglass type) or clean (permanent, foam type) as necessary.
2. Lubrication Requirements – The indoor circulating air blower motor and outdoor circulating air fan motor are permanently lubricated and require no re-oiling. The combustion air blower motor requires no re-oiling.

WARNING

Turn off electrical power supply to prevent injury from moving parts or electric shock.

ROUTINE INSPECTION

1. Inspect the physical support of the unit annually to make sure it is securely fastened to the building. Also look for any obvious signs of deterioration.
2. Inspect the pilot and main burner adjustment at the beginning of each heating season. Refer to Figure 7 and Figure 8 for general guidelines. Call qualified service agency for any adjustments.
3. Inspect the vent terminal for any obvious deterioration, to make sure it is free and clear of any obstructions.

26. REPLACEMENT PARTS

WARNING

Use replacement parts listed in parts list. Failure to do so could cause improper furnace operation, resulting in property damage, personal injury, or death.

Replacement parts for the gas/electric units are available through local distributors.

A replacement parts list manual is supplied with each unit. When ordering parts or making inquiries pertaining to any of the units covered by these instructions, it is very important to always supply the COMPLETE model number and serial number of the unit. This is necessary to assure that the correct parts (or an approved alternate part) are issued to the service agency.

27. SEQUENCE OF OPERATION – HEATING

On a call for heat from the thermostat, the induced draft blower relay is energized through the normally closed contacts of the air proving pressure switch. At this point the induced draft blower starts its operation. Once sufficient draft is established, the ignition system is energized through the normally open contacts of the air proving pressure switch. The pilot ignitor will heat up and the pilot valve will be energized allowing pilot gas to flow. Upon establishment of the pilot burner flame, adequate flame for burner ignition is proved to the control system allowing the main gas valve to be energized and to discontinue igniter. At the same time the main valve is energized, a one minute blower delay timer is activated.

After this delay, the low speed blower relay energizes. The blower will begin operating and remain in operation until two minutes after the call for heat has been satisfied. This timing sequence guarantees blower on, blower off operation.

This unit is equipped with a flame rollout switch which is wired in series with the control circuit. This is a manual reset switch and is used for the purpose of preventing possible fire hazard in the event of a system malfunction. If this switch has opened the control circuit, there could be a possible system malfunction. Some of the conditions that might cause a rollout to occur are blockage or sooting of primary heat exchanger, overfiring of furnace due to improper main burner orifices or incorrect manifold pressure, insufficient combustion air, or installation deficiencies with respect to return air duct design or sizing.

Once the problem has been resolved, reset the switch by pressing down on the reset button on top of the switch.

See Figure 12 for additional information.

28. SEQUENCE OF OPERATION – COOLING

On a call for cooling from the room thermostat, the high speed blower relay will be energized as well as the compressor contactor. Following termination of the cooling cycle, the blower motor will continue to run for one minute.

See Figure 12 for additional information.

29. INDOOR BLOWER OPERATION

All models have two speed direct drive indoor blower motors. If supply and return ducts are connected to the unit, the ducts must be of adequate size. Refer to the appropriate blower curve, see Figure 11, for maximum static pressures acceptable. Note the minimum CFM for cooling operation is 810. As produced, the circulating blower will operate on high speed during cooling and low speed during heating.

If voltage and duct design permit, (see blower curves) single speed operation can be achieved as follows:

1. Disconnect main power supply to unit.
2. Remove the unwanted indoor motor speed tap (red low, black high) from the blower control. This wire is to be connected to terminal marked "UNUSED MOTOR LEADS". See Figure 10.
3. Next install a jumper wire with multiplier between HEAT and COOL terminals and attach desired blower motor speed lead to other side of multiplier.
4. Energized the system in cooling and heating modes and check for proper blower operation.

FIGURE 10

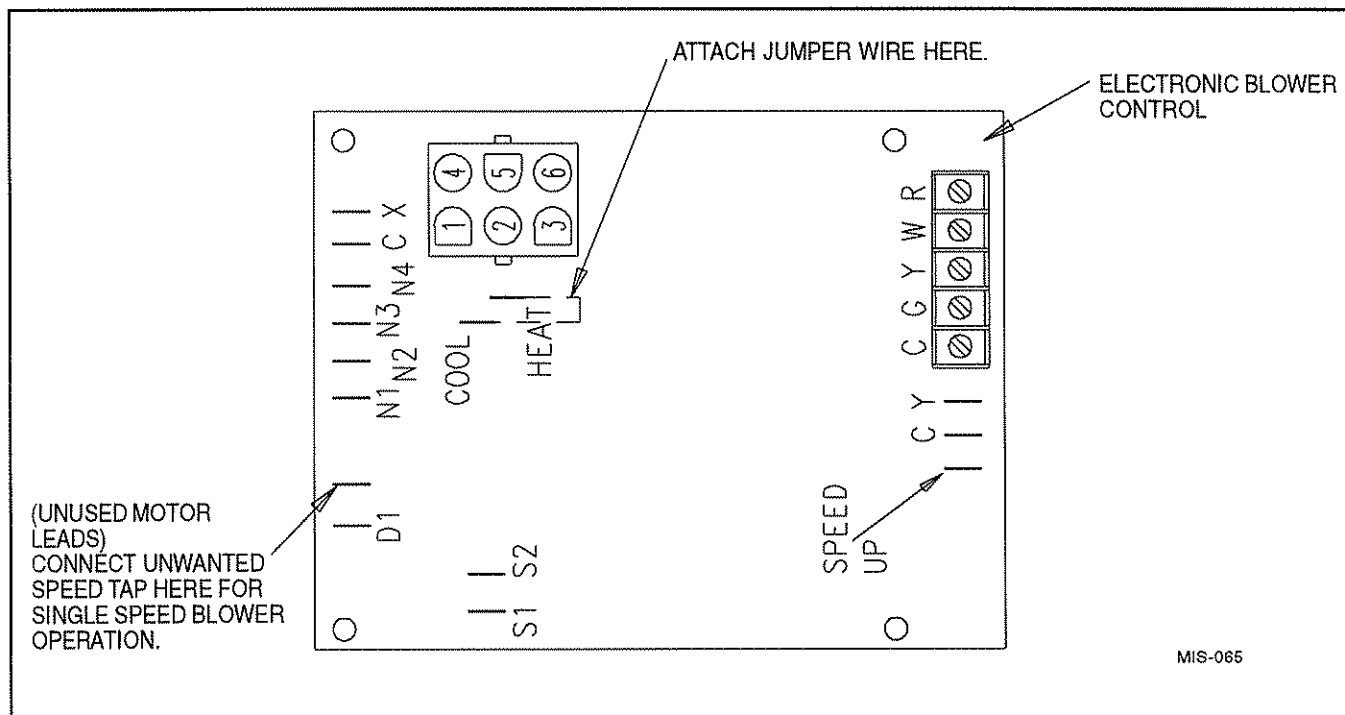

MIS-065

FIGURE 11

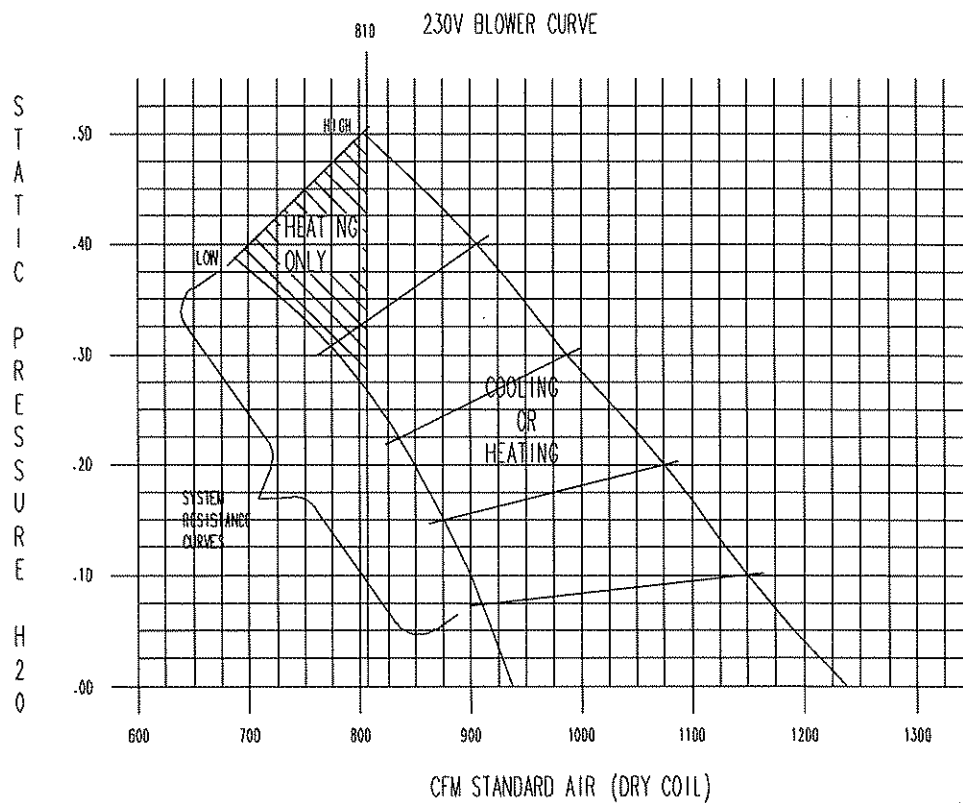
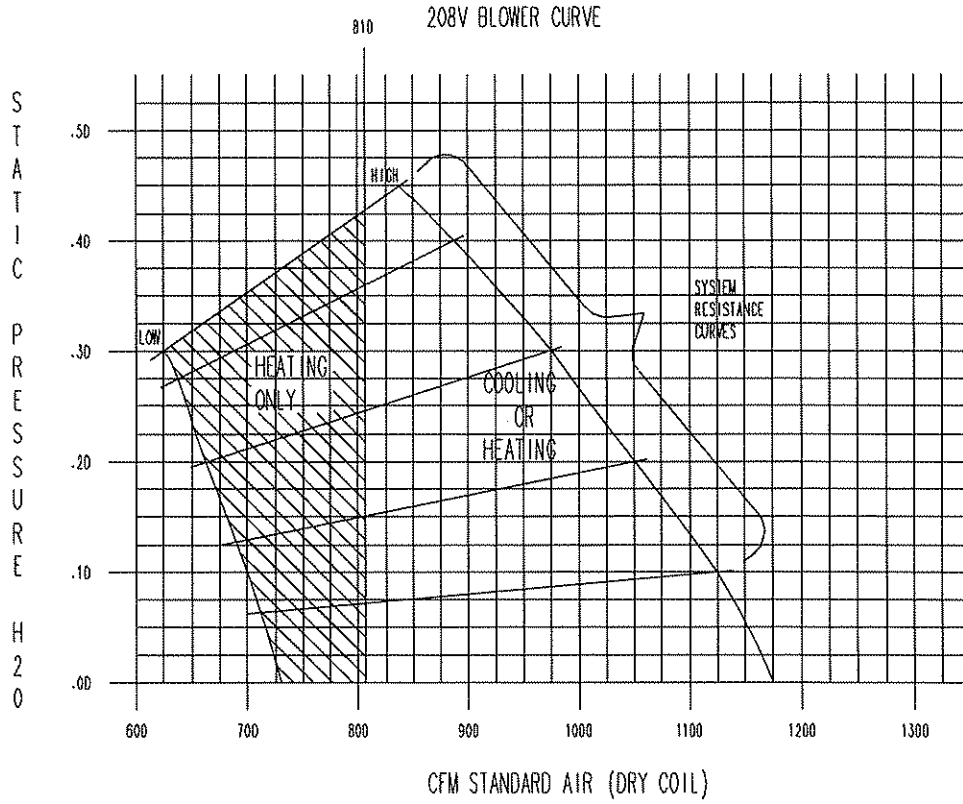

MIS-063

FIGURE 12

SEQUENCE OF OPERATION – ELECTRONIC BLOWER CONTROL

ACTION	SYSTEM RESPONSE
Thermostat calls for heat. (W terminal is energized.)	<ul style="list-style-type: none"> • Combustion air blower is energized. • Air proving switch makes. Air flow is established. • Ignition system is energized. • Gas valve opens and main burner lights. • Heat fan on delay timing begins. When timing is complete, the circulating fan is energized at heat speed.
Thermostat ends call for heat.	<ul style="list-style-type: none"> • Ignition system is de-energized and gas valve closes. • Combustion air blower is de-energized after postpurge timing. • Heat fan off delay timing begins. When timing is complete, the circulating fan is de-energized.
Thermostat begins call for cool. (G and Y terminals re-energized.)	<ul style="list-style-type: none"> • Cooling contactor is energized. • Circulating fan is energized at cool speed after cool fan on delay timing.
Thermostat begins call for fan. (G terminal is de-energized.)	<ul style="list-style-type: none"> • Circulating fan is de-energized.
Limit (flame rollout) opens.	<ul style="list-style-type: none"> • Thermostat and ignition system are de-energized and gas valve closes. • Combustion air blower and circulating fan heat speed are energized.
Limit (auto reset) or flame rollout (manual reset) circuit closed.	<ul style="list-style-type: none"> • Combustion air blower remains energized for postpurge timing. • The circulating fan remains energized for the selected delay off timing. • Normal operation resumes.

30. SMARTVALVE™ HSI IGNITION TROUBLESHOOTING FLOW CHART

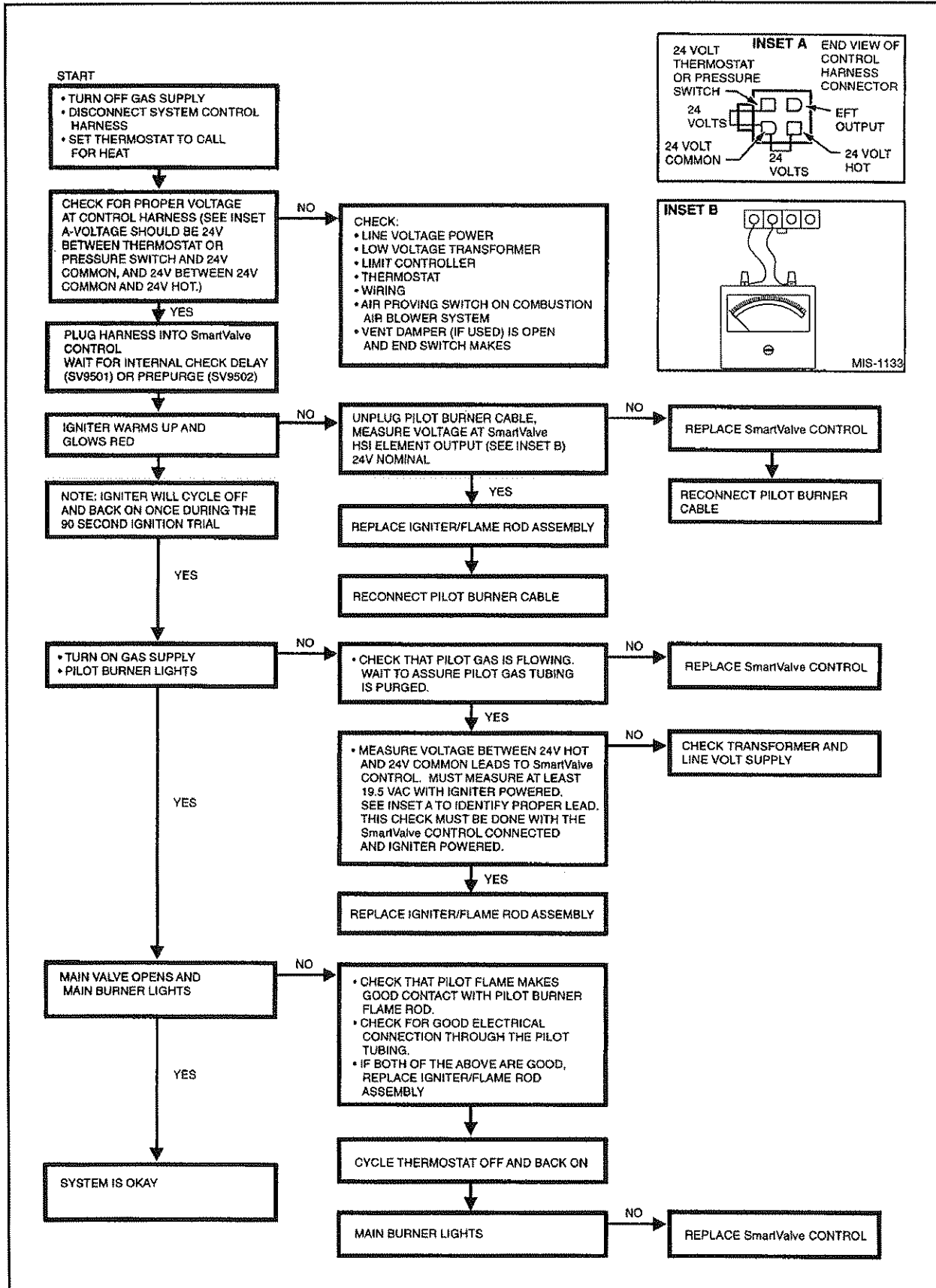

31. PRESSURE SERVICE PORTS

High and low pressure service ports are installed on all units so that the system operating pressures can be observed. Table 9 outlines expected pressures at various indoor and outdoor temperatures.

TABLE 9 – COOLING

			Air Temperature Entering Outdoor Coil Degree F								
Model	Return Air Temperature	Pressure	75	80	85	90	95	100	105	110	115
WAG30D	75 deg. DB	Low Side	69	71	73	75	77	79	80	81	82
	62 deg. WB	High Side	208	225	242	260	277	294	311	328	345
	80 deg. DB	Low Side	74	76	78	80	82	84	85	87	88
	67 deg. WB	High Side	213	231	249	266	294	302	319	337	354
	85 deg. DB	Low Side	80	82	84	86	88	90	92	93	95
	72 deg. WB	High Side	220	239	257	276	290	312	330	348	366
WAG36D	75 deg. DB	Low Side	64	67	70	72	74	76	77	79	80
	62 deg. WB	High Side	210	223	238	253	268	284	301	318	336
	80 deg. DB	Low Side	69	72	74	77	79	81	83	85	86
	67 deg. WB	High Side	215	229	244	259	275	292	309	327	345
	85 deg. DB	Low Side	73	77	80	83	85	87	89	91	92
	72 deg. WB	High Side	222	237	252	268	285	302	320	338	357
WAG40D	75 deg. DB	Low Side	62	64	66	68	70	72	73	75	76
	62 deg. WB	High Side	211	224	237	252	267	283	301	319	339
	80 deg. DB	Low Side	65	68	71	73	75	77	78	80	81
	67 deg. WB	High Side	217	230	243	258	274	291	309	328	348
	85 deg. DB	Low Side	69	73	76	79	81	83	85	86	87
	72 deg. WB	High Side	224	237	252	267	284	302	320	340	360

32. REFRIGERANT CHARGE

The correct system R-22 charge is shown on the unit rating plate. Optimum unit performance will occur with a refrigerant charge resulting in a suction line temperature (6" from compressor) as shown in Table 10.

The suction line temperatures in Table 9 are based upon 80 degrees F dry bulb / 67 degree wet bulb (50% R.H.) temperature and rated airflow across the evaporator during cooling cycle.

TABLE 10

Model	Rated Airflow	95 Deg. F OD Temp.	82 Deg. F OD Temp.
WAG30D	1000	51 - 53	66 - 68
WAG36D	1000	49 - 51	66 - 68
WAG40D	1000	50 - 52	65 - 67

33. FAN BLADE SETTING DIMENSIONS

Shown in Figure 13 are the correct fan blade setting dimensions for proper air delivery across the outdoor coil.

Any service work requiring removal or adjustment in the fan and/or motor area will require that the dimensions below be checked and blade adjusted in or out on the motor shaft accordingly.

FIGURE 13

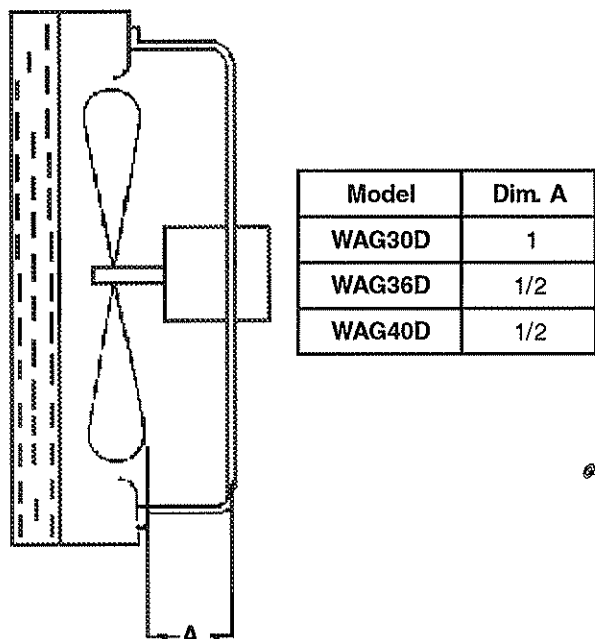

34. LO-NO_x BURNER ASSEMBLY X SUFFIX MODELS ONLY – U.S. INSTALLATIONS ONLY

(X) suffix models comply with South Coast Air Quality Management District Rule 1111 and Bay Area Air Quality Management District Regulation 9, Rule 4 for nitrous oxide emission levels. All (X) suffix model components are identical to (C) suffix components except for the burner assembly detailed in Figure 14 and Table 11

⚠ CAUTION

"X" suffix low NO_x models not approved for LP gas conversion.

FIGURE 14

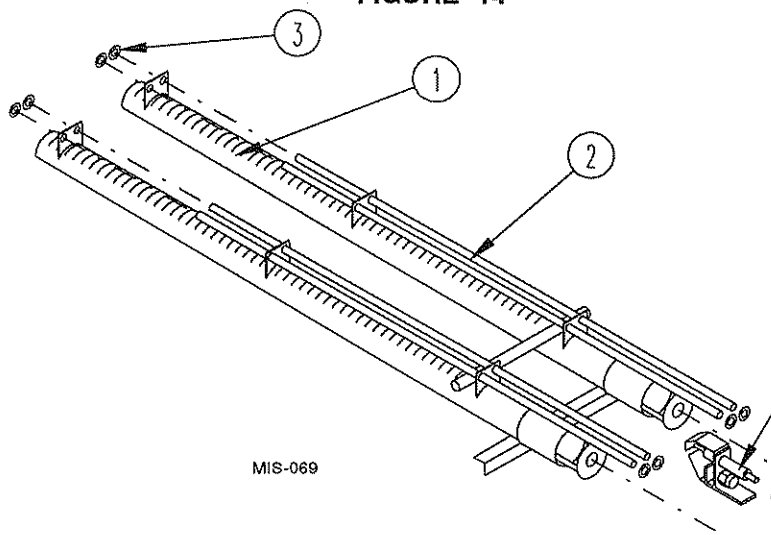
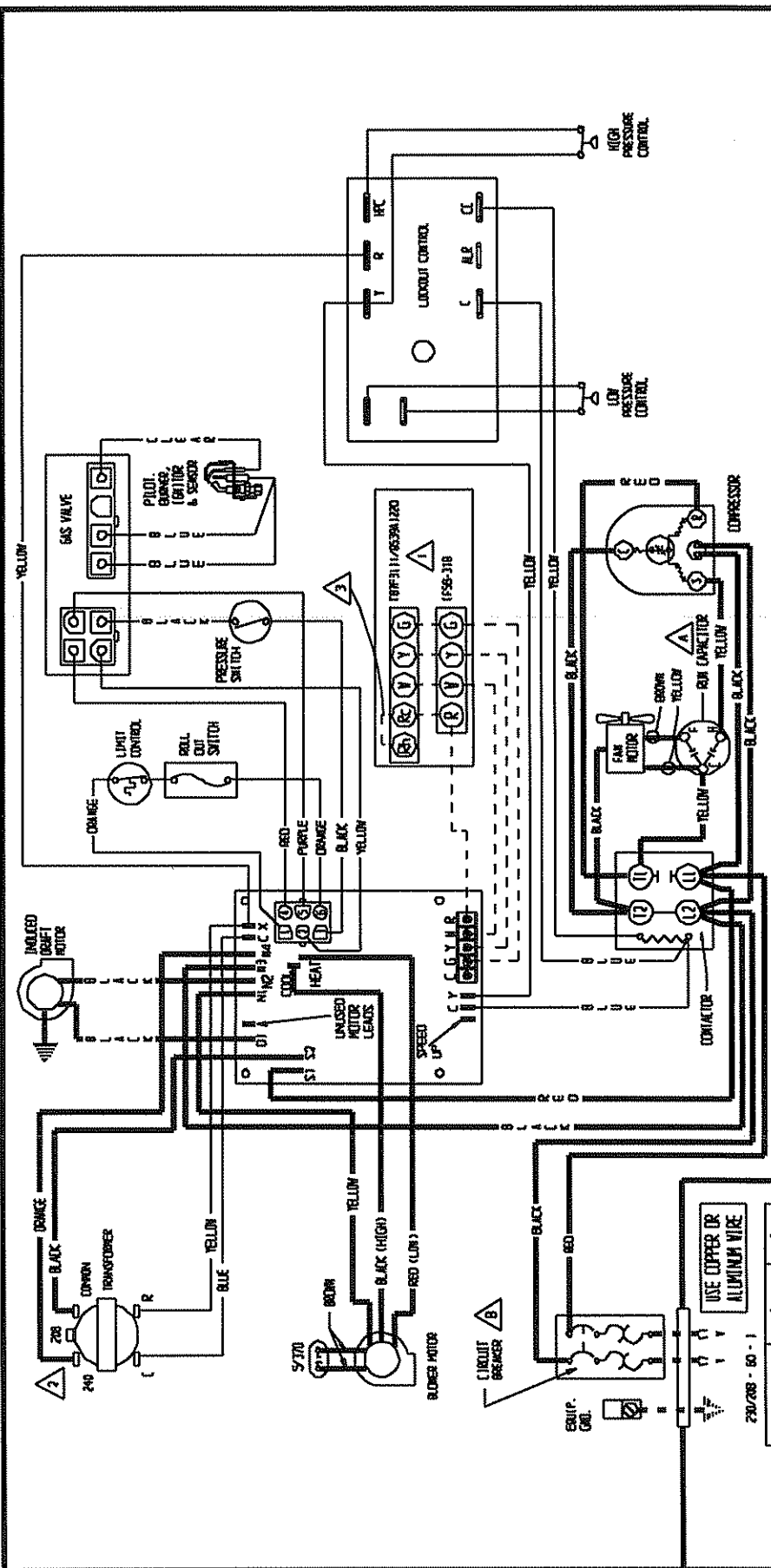

TABLE 11

Item No.	Part No.	Description	WAG30D-A54X	WAG36D-A54X	WAG36D-B54X	WAG36D-C54X	WAG40D-A54X	WAG40D-B54X	WAG40D-C54X
	901-0073	Burner Assembly (Complete)	X	X	X	X	X	X	X
1	163-025	Burner (2 Cell) Weld Assembly	X	X	X	X	X	X	X
2	2200-018	Stainless Steel Rods	(4)	(4)	(4)	(4)	(4)	(4)	(4)
3	1012-310	Stainless Steel Tinnerman	(8)	(8)	(8)	(8)	(8)	(8)	(8)

CONNECTION DIAGRAM DANGER: ELECTRICAL SHOCK HAZARD, DISCONNECT POWER BEFORE SERVICING



IF ANY OF THE ORIGINAL WIRE AS SUPPLIED WITH THE APPLIANCE MUST BE REPLACED, IT MUST BE REPLACED WITH WIRING MATERIAL HAVING A TEMPERATURE RATING OF AT LEAST 105°C EXCEPT THE IGNITION CABLE WHICH IS 250°C HIGH VOLTAGE CABLE.

Low Voltage	High Voltage
FACTORY WIRING	FIELD WIRING

MODEL	USE COPPER OR ALUMINUM WIRE	CIRCUIT BREAKER
W4600-154K	35/5/370	25A
W4600-154L	40/10/370	20A
W4600-154E	40/10/440	45A

4085-114 B

LADDER DIAGRAM

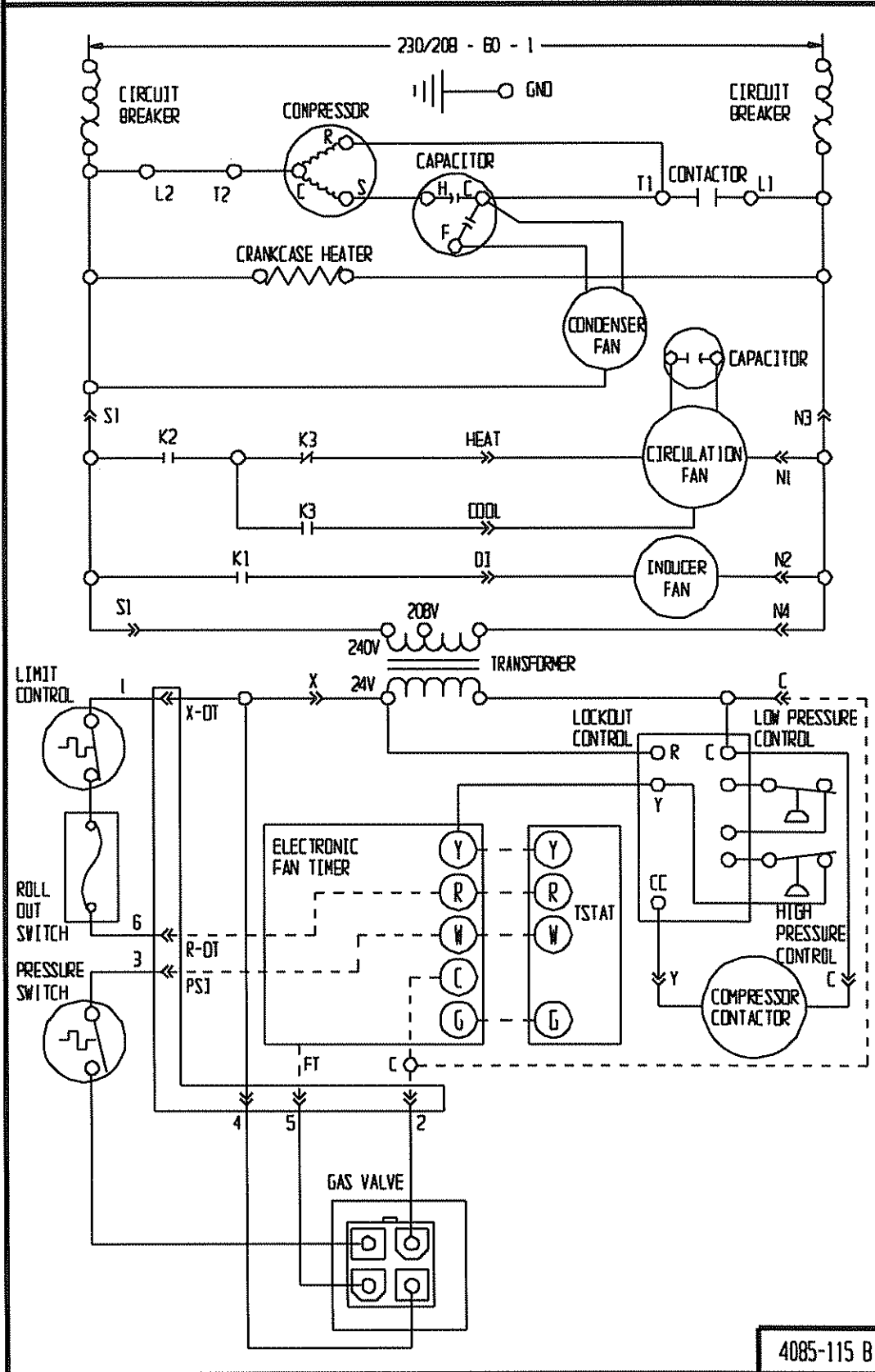

4085-115 B

CONNECTION DIAGRAM DANGER: ELECTRICAL SHOCK HAZARD, DISCONNECT POWER BEFORE SERVICING

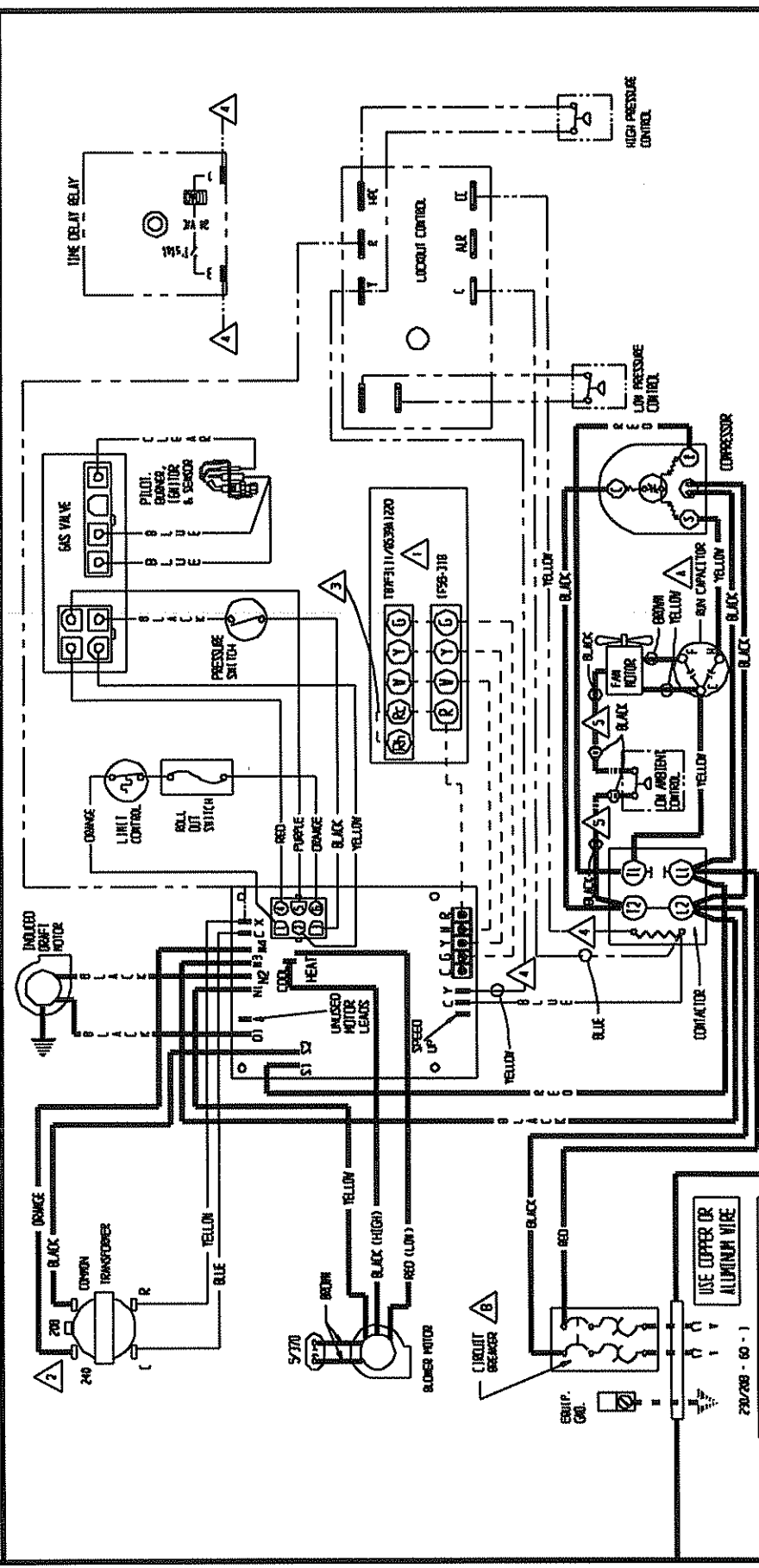

IF ANY OF THE ORIGINAL WIRE AS SUPPLIED WITH THE APPLIANCE MUST BE REPLACED, IT MUST BE REPLACED WITH WIRING MATERIAL HAVING A TEMPERATURE RATING OF AT LEAST 105°C EXCEPT THE IGNITION CABLE WHICH IS 250°C HIGH VOLTAGE CABLE.

FACTORY STD.	FIELD	OPTIONAL
HIGH VOLTAGE	---	---
LOW VOLTAGE	---	---
NECESSARY	---	---

- 1 SET HEAT ANTICIPATOR AT 5.1
- 2 FOR 208V OPERATION WIRE THIS WIRE TO 208V TRANSFORMER TAP
- 3 AND JUMPER 2c - 2d
- 4 AND JUMPER 2c - 2d
- 5 LABELLED WIRES CONNECT IF NO OPTIONS USED

MODEL	MIN. CIRCUIT BREAKER	MIN. FUSE
W4300-454C	35/5/270	35A
W4300-754C	40/10/270	40A
W4300-154C	40/10/440	45A

4005-116 B

LADDER DIAGRAM

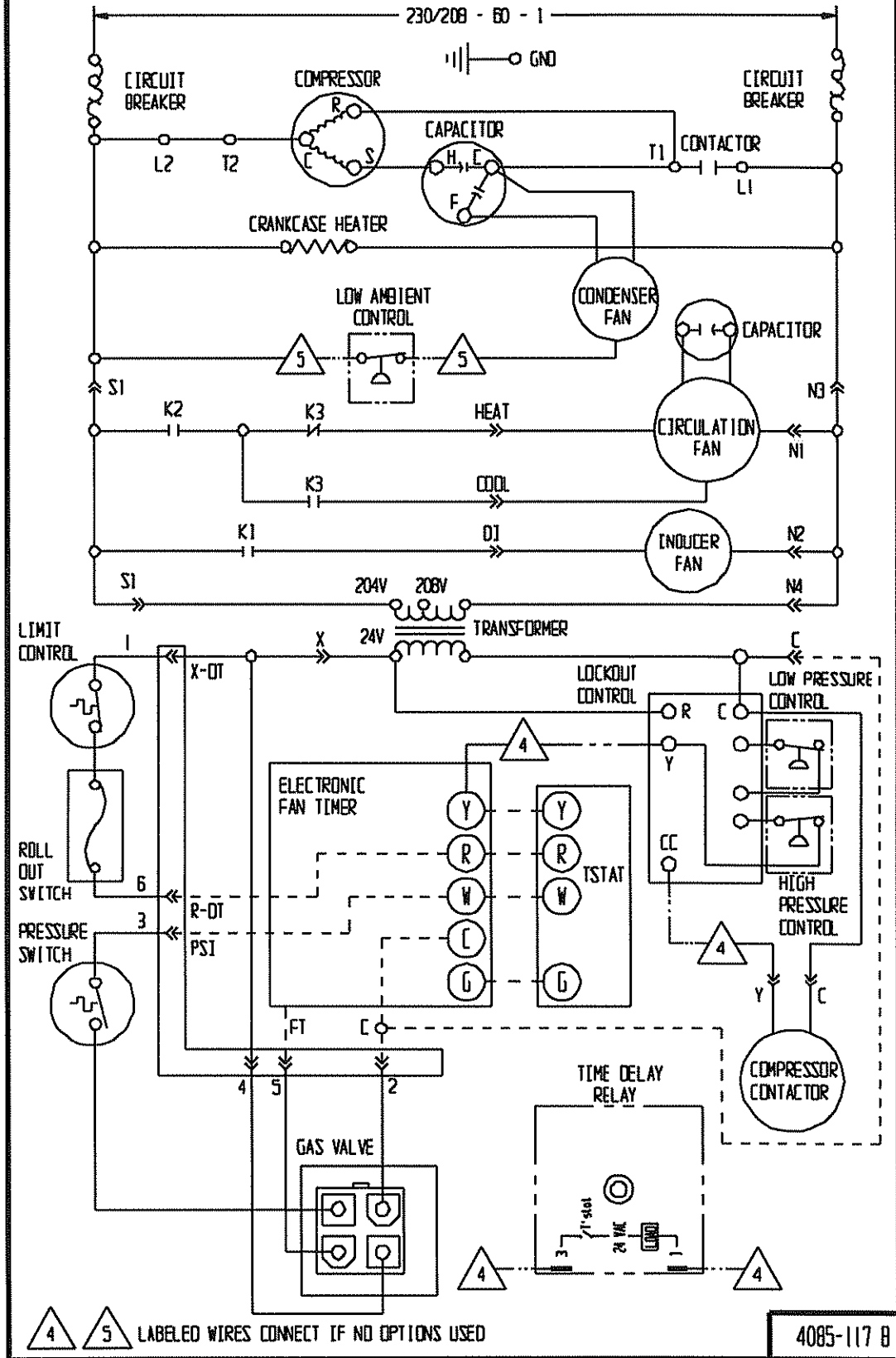

CONNECTION DIAGRAM

DANGER: ELECTRICAL SHOCK HAZARD,
DISCONNECT POWER BEFORE SERVICING

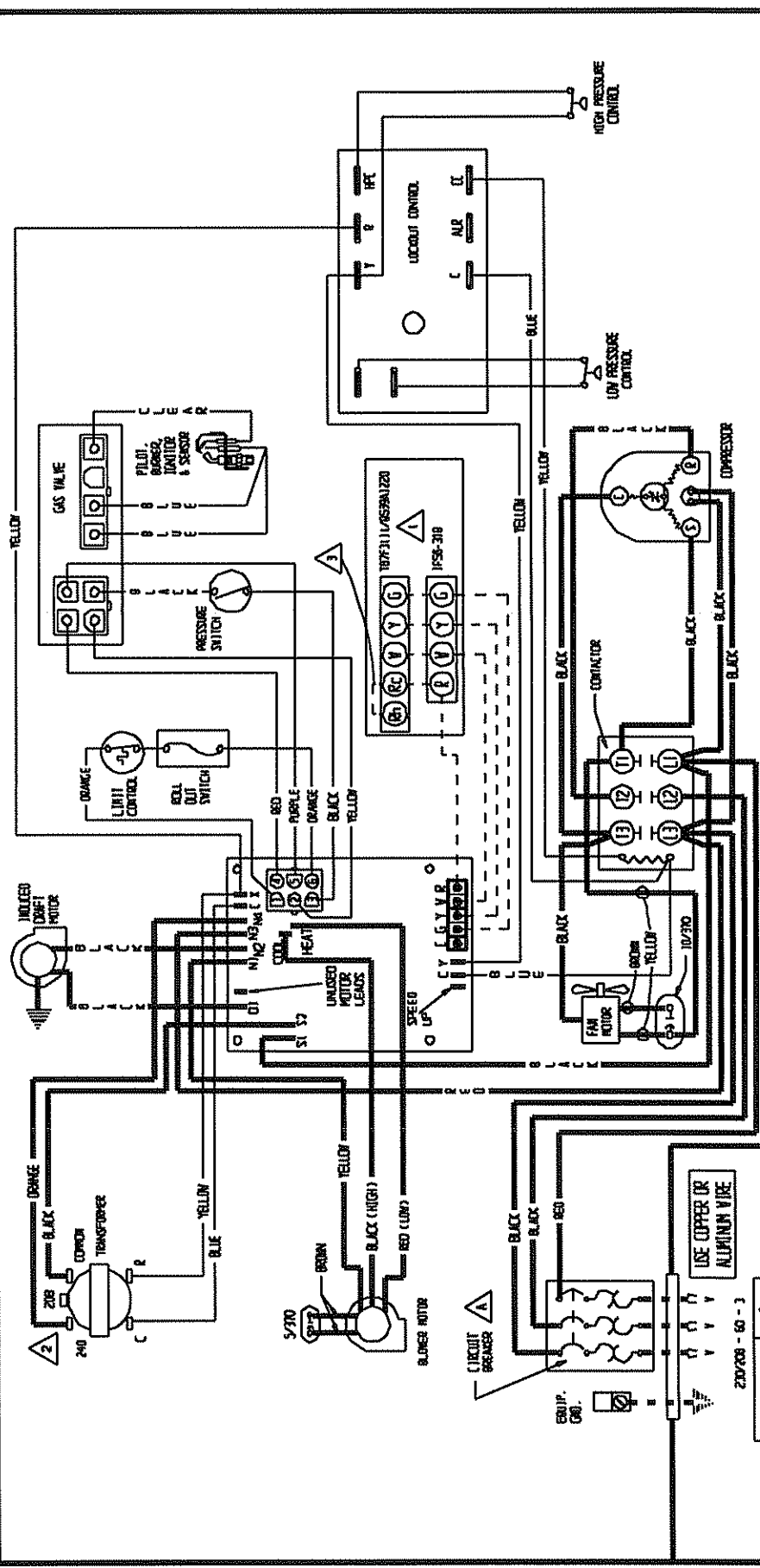

IF ANY OF THE ORIGINAL WIRE AS SUPPLIED WITH THE APPLIANCE MUST BE REPLACED, IT MUST BE REPLACED WITH WIRING MATERIAL HAVING A TEMPERATURE RATING OF AT LEAST 105°C EXCEPT THE IGNITION CABLE WHICH IS 250°C HIGH VOLTAGE CABLE.

Low Voltage	FACTORY WIRING	FIELD WIRING
High Voltage

USE COPPER OR ALUMINUM WIRE

MODEL	2100-278
CIRCUIT BREAKER	30A
WASHER-HEAT	30A
WASHER-HEAT	30A

4085-214 B

LADDER DIAGRAM

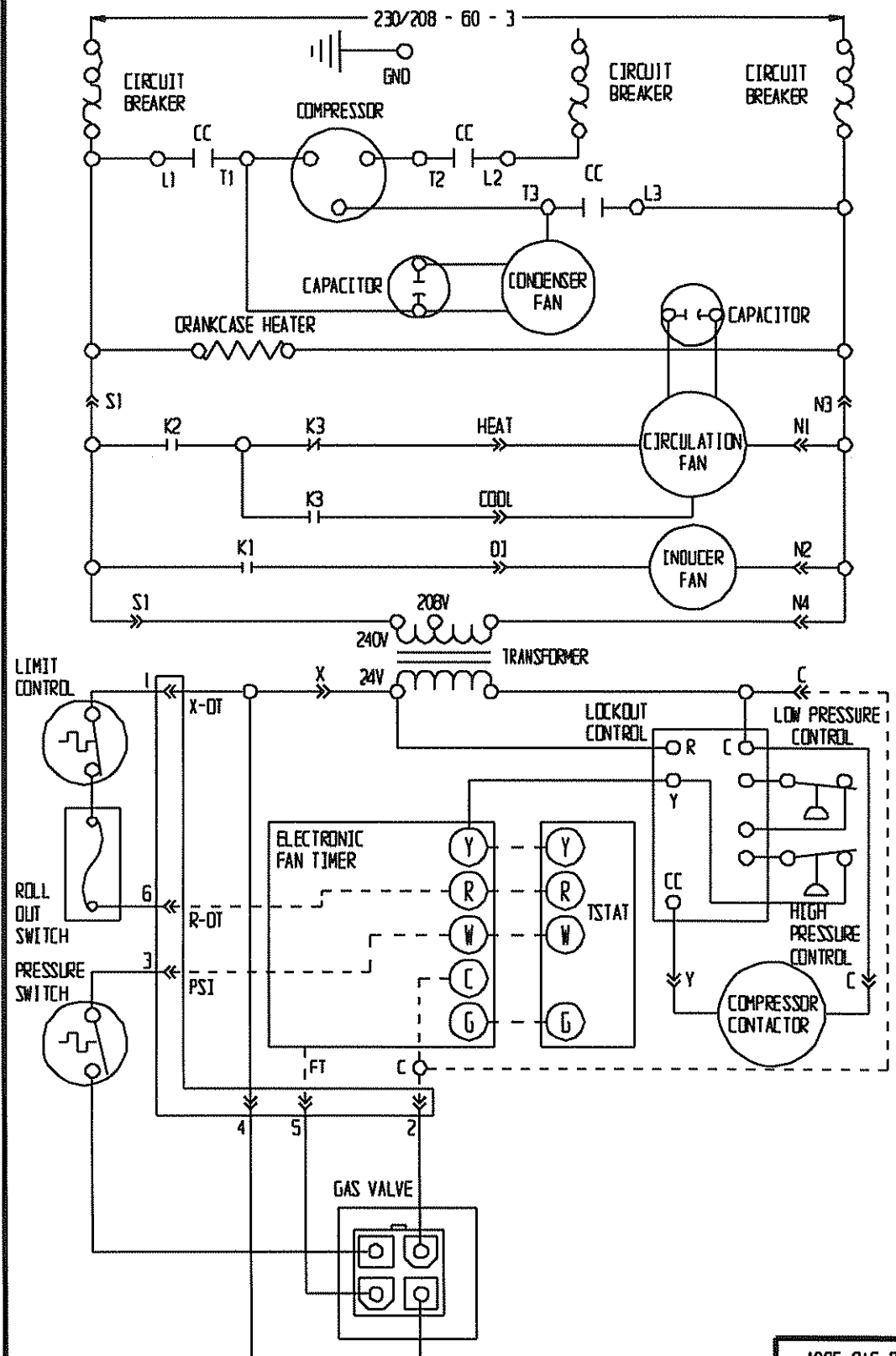

4085-215 B

CONNECTION DIAGRAM
DANGER: ELECTRICAL SHOCK HAZARD,
DISCONNECT POWER BEFORE SERVICING

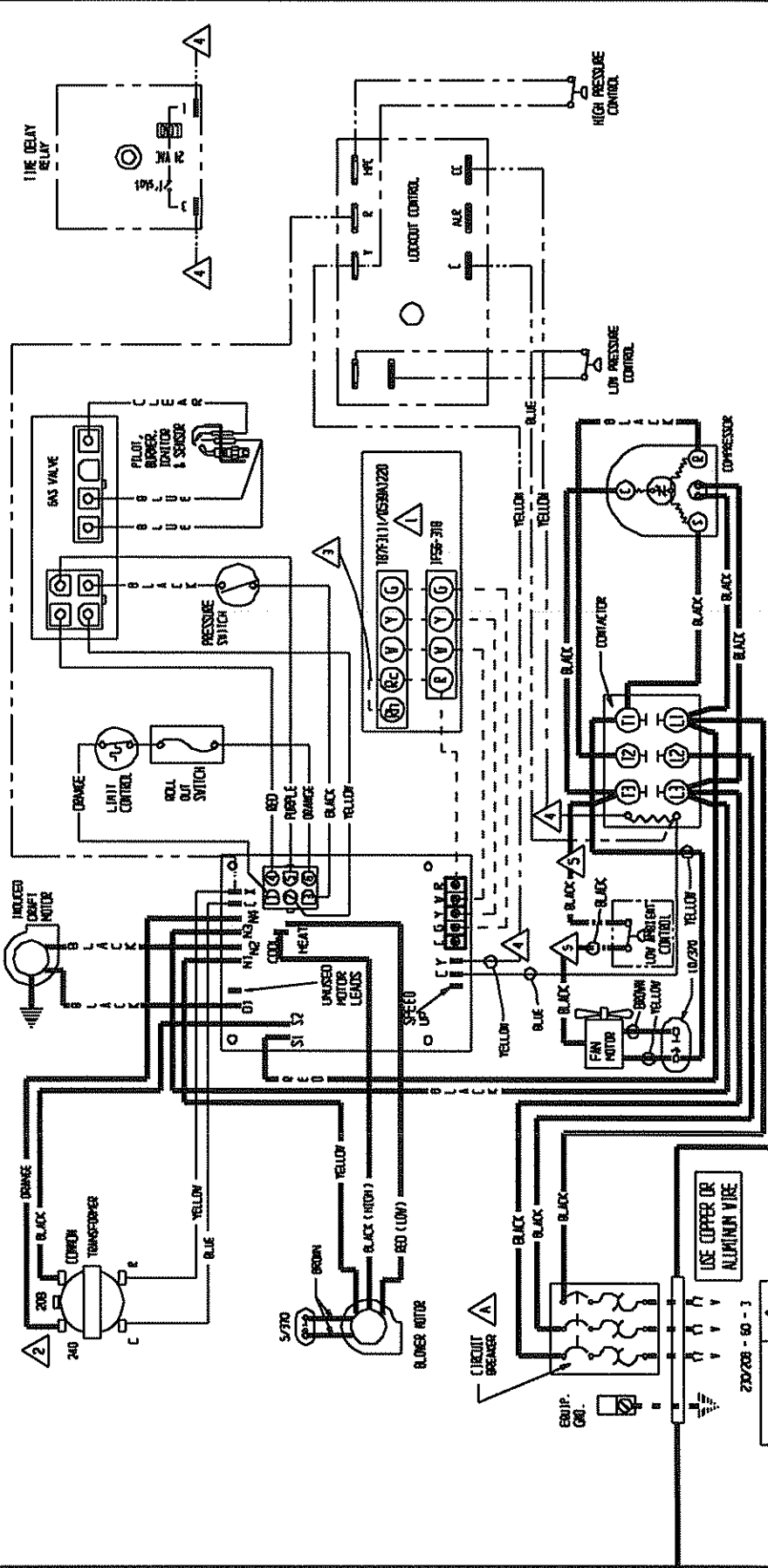

IF ANY OF THE ORIGINAL WIRE AS SUPPLIED WITH THE APPLIANCE MUST BE REPLACED, IT MUST BE REPLACED WITH WIRING MATERIAL HAVING A TEMPERATURE RATING OF AT LEAST 105°C EXCEPT THE IGNITION CABLE WHICH IS 250°C HIGH VOLTAGE CABLE.

FACTORY STD.	FED	OPTIONAL
HIGH VOLTAGE	---	----
LOW VOLTAGE	---	----
ACCESSORY	---	----

- 1 SET HEAT ANTICIPATOR AT 64
- 2 FOR 208V OPERATION WIRE THIS WIRE TO 208V TRANSFORMER TAP
- 3 AND JUMPER B2 - ON
- 4 AND JUMPER B2 - ON
- 5 LABELED WIRES CONNECT IF NO OPTIONS USED

4005-216 C

LADDER DIAGRAM

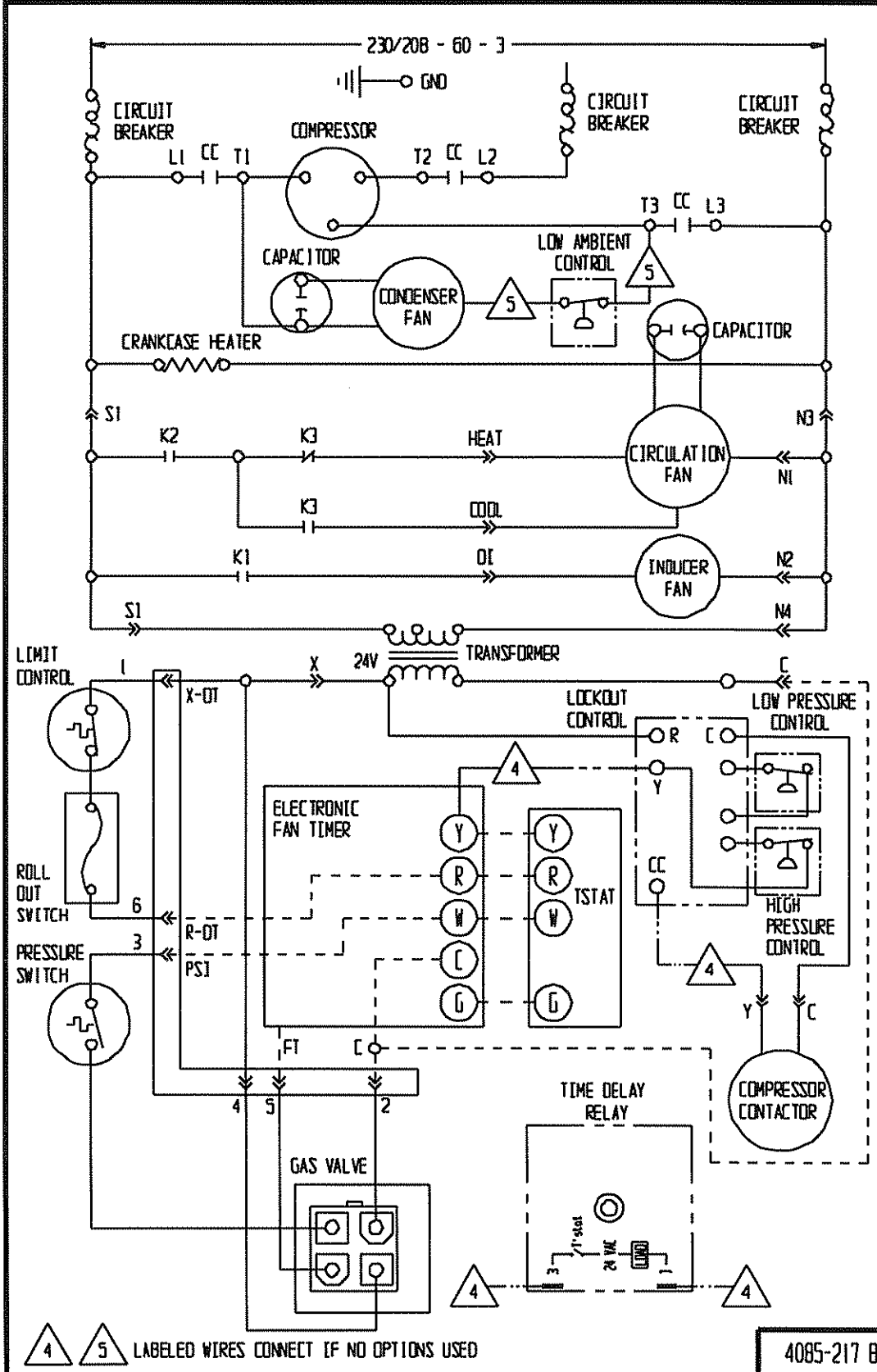

CONNECTION DIAGRAM

DANGER: ELECTRICAL SHOCK HAZARD,
DISCONNECT POWER BEFORE SERVICING

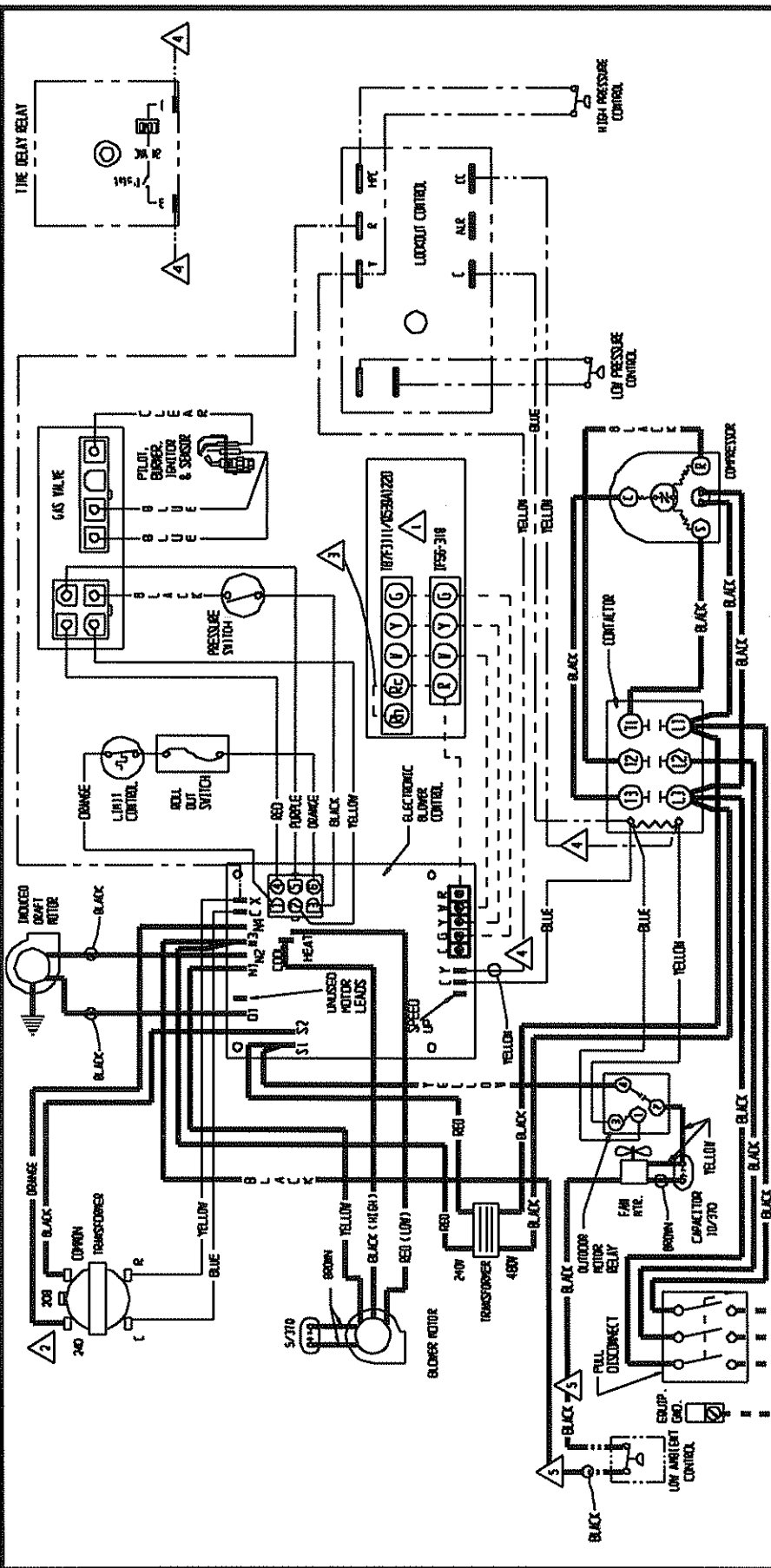

	FACTORY STD.	FEED	OPTIONAL
HIGH VOLTAGE	---	---	---
LOW VOLTAGE	---	---	---
ACCESSORY	---	---	---

USE COPPER OR
ALUMINUM WIRE

IF ANY OF THE ORIGINAL WIRE AS SUPPLIED WITH THE APPLIANCE MUST BE REPLACED, IT MUST BE REPLACED WITH WIRING MATERIAL HAVING A TEMPERATURE RATING OF AT LEAST 105°C EXCEPT THE IGNITION CABLE WHICH IS 200°C HIGH VOLTAGE CABLE.

480-80-3

LADDER DIAGRAM

