

Installation Instructions

Wall Mounted Packaged Air Conditioner

Models: WA701, WA721

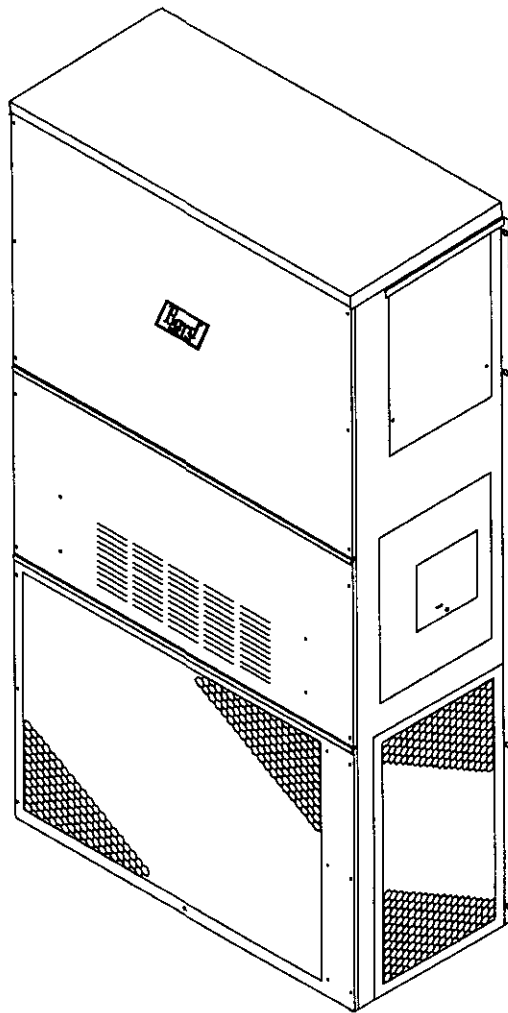

Bard Manufacturing Company
Bryan, Ohio 43506

*Since 1914...Moving ahead, just as
planned.*

Manual No.: 2100-266 Rev. D
File: Volume III, Tab 16
Date: 05/15/96

Contents

Getting Other Information and Publications	1
For more information, contact these publishers	1
Wall Mount General Information	2
Air Conditioner Wall Mount Model Nomenclature	2
Shipping Damage	4
General	4
Duct Work	4
Filters	5
Fresh Air Intake	5
Condensate Drain	5
Installation Instructions	6
Wall Mounting Information	6
Mounting the Unit	6
Wiring — Main Power	6
Wiring — Low Voltage Wiring	6

Start Up	11
Important Installer Note	11
Crankcase Heaters	11
Service Hints	11
Sequence of Operation	11
Pressure Service Ports	11
Troubleshooting	12
Fan Blade Setting Dimensions	12
Removal of Fan Shroud	12
Refrigerant Charge	12
Optional Accessories	13

Figures

Figure 1	Unit Dimensions	3
Figure 2	Blower Damper Assembly	5
Figure 3	Mounting Instructions	7
Figure 4	Wall-Mounting Instructions	8
Figure 5	Wall-Mounting Instructions	8
Figure 6	Common Wall-Mounting Installations	9
Figure 7	Electric Heat Clearances	10
Figure 8	Wiring	10
Figure 9	Start-Up Label	11
Figure 10	Fan Blade Setting	12

Tables

Table 1	Electrical Specifications	2
Table 2	Dimensions of Basic Unit	3
Table 3	Electric Heat Table	3
Table 4	Operating Voltage Range	6
Table 5	Thermostat Wire Size	7
Table 6	Wall Thermostat and Subbase Combinations	7
Table 7	Fan Blade Dimensions	12
Table 8	Suction Line Temperatures	12
Table 9	Indoor Blower Performance	12
Table 10	CFM and ESP	12
Table 11	Maximum ESP of Operation Electric Heat Only	12
Table 12	Cooling Pressure	13
Table 13	Optional Accessories	13

Getting Other Information and Publications

These publications can help you install the air conditioner or heat pump. You can usually find these at your local library or purchase them directly from the publisher. Be sure to consult current edition of each standard.

National Electrical Code ANSI/NFPA 70

Standard for the Installation ANSI/NFPA 90A
of Air Conditioning and
Ventilating Systems

Standard for Warm Air ANSI/NFPA 90B
Heating and Air
Conditioning Systems

Load Calculation for ACCA Manual J or
Residential Winter and Manual N
Summer Air Conditioning

Low Pressure, Low Velocity Duct ACCA Manual D or
System Design for Winter and Manual Q
Summer Air Conditioning

For more information, contact these publishers:

ACCA — Air Conditioning Contractors of America
1513 16th Street N.W.
Washington, DC 20036
Telephone: (202) 483-9370
Fax: (202) 234-4721

ANSI — American National Standards Institute
11 West Street, 13th Floor
New York, NY 10036
Telephone: (212) 642-4900
Fax: (212) 302-1286

**ASHRAE — American Society of Heating Refrigerating, and
Air Conditioning Engineers, Incorporated**
1791 Tullie Circle, N.E.
Atlanta, GA 30329-2305
Telephone: (404) 636-8400
Fax: (404) 321-5478

NFPA — National Fire Protection Association
Batterymarch Park
P.O. Box 9101
Quincy, MA 02269-9901
Telephone: (800) 344-3555
Fax: (617) 984-7057

Manufactured under the following U.S. patent numbers:

5,301,744; 5,002,116; 4,924,934; 4,875,520; 4,825,936; 4,432,409

Other patents pending.

Wall Mount General Information

Air Conditioner Wall Mount Model Nomenclature

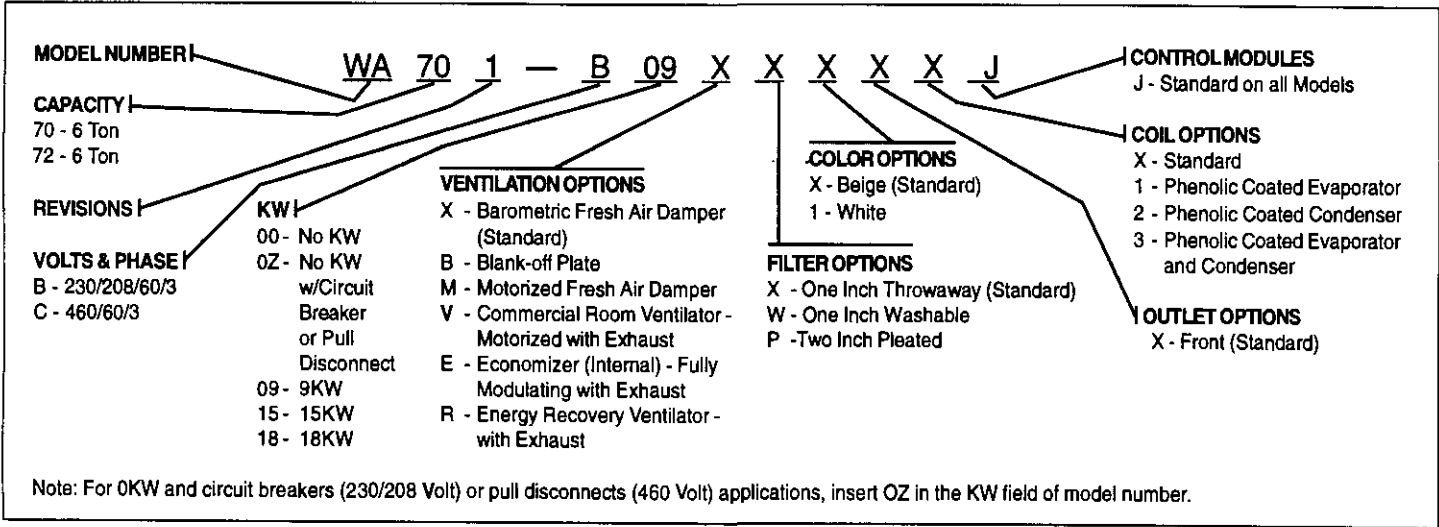

Table 1 — Electrical Specifications

MODELS	RATED VOLTS AND PHASE	NO. FIELD POWER CKTS.	MINIMUM CIRCUIT AMPACITY ③	MAXIMUM EXTERNAL FUSE OR CIRCUIT BREAKER ①	FIELD POWER WIRE SIZE ②	GROUND WIRE SIZE ②
WA701-B00, B0Z	230/208-3	1	36	50	8	10
B09		1	36	50	8	10
B15		1	52	60	6	10
B18		1	60	60	6	10
WA701-C00, C0Z	460-3	1	17	25	12	12
C09		1	17	25	12	12
C15		1	26	30	10	10
WA721-B00, B0Z	230/208-3	1	36	50	8	10
B09		1	36	50	8	10
B15		1	52	60	6	10
B18		1	60	60	6	10

① Maximum size of the time delay fuse or HACR type circuit breaker for protection of field wiring conductors.

② Based on 75°C copper wire. All wiring must conform to the National Electrical Code (NEC) and all local codes.

③ These "Minimum Circuit Ampacity" values are to be used for sizing the field power conductors. Refer to the National Electric Code (latest revision), article 310 for power conductor sizing. Caution: When more than one field power conductor circuit is run through one conduit, the conductors must be derated. Pay special attention to note 8 of Table 310 regarding Ampacity Adjustment Factors when more than 3 conductors are in a raceway.

Table 2 — Dimensions of Basic Unit for Architectural and Installation Requirements (Nominal)

UNIT	WIDTH (W)	DEPTH (D)	HEIGHT (H)	SUPPLY		RETURN		E	F	G	I	J	K	L	M	N	O	P	Q
				A	B	C	B												
WA701	42	22-1/4	94-7/8	9-7/8	29-7/8	15-7/8	29-7/8	43-7/8	19	41-5/8	30	42-11/16	37	44-3/4	42-1/2	3-1/4	43	33-7/8	10
WA721																			

All dimensions are in inches

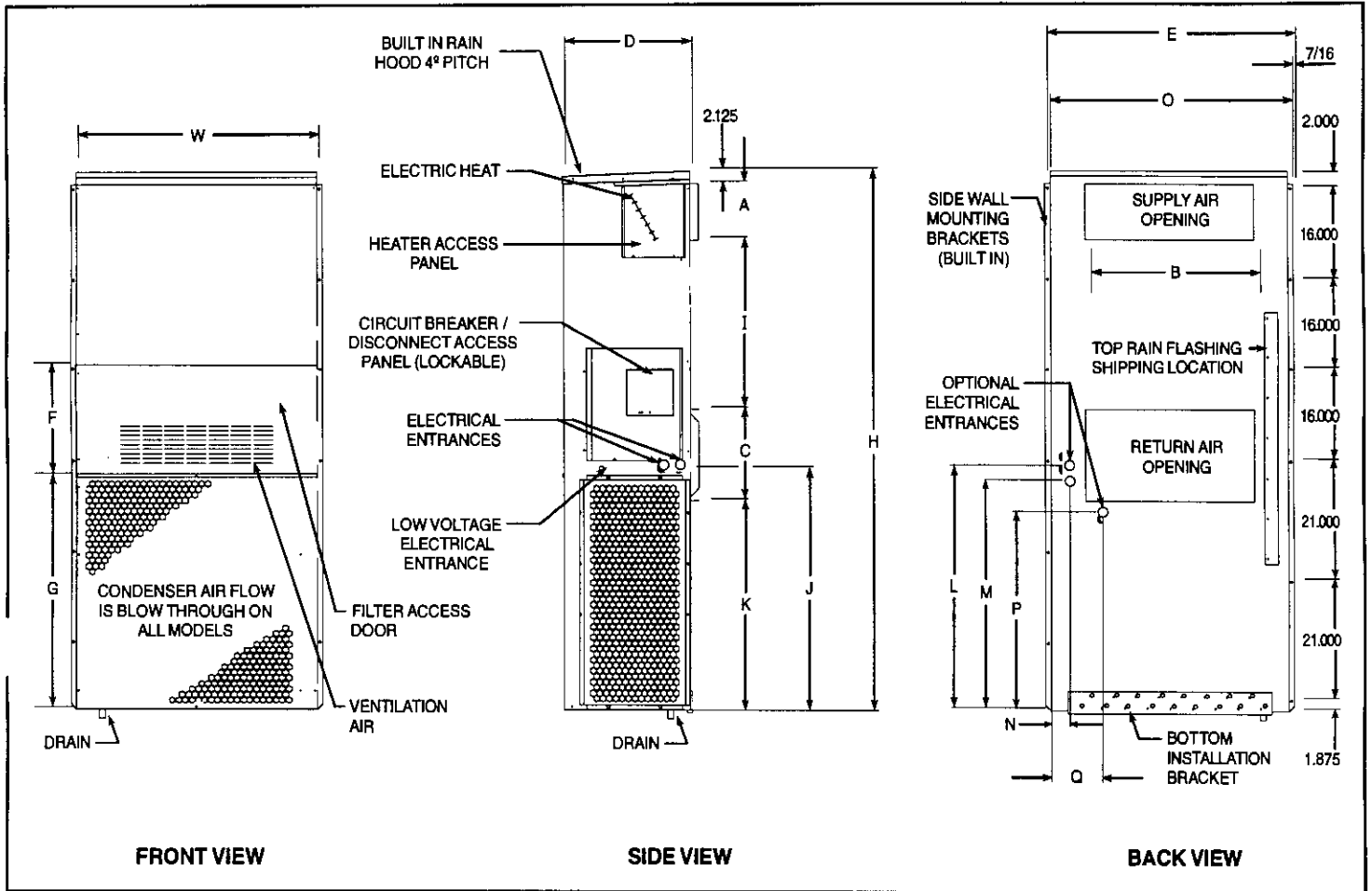

Figure 1 — Unit Dimensions

Table 3 — Electric Heat Table

MODELS	WA701-B WA721-B						WA701-C	
	240V-3		208V-3		460V-3			
	KW	AMPS	BTUH	AMPS	BTUH	AMPS	BTUH	
9.0	21.7	30,600	18.7	23,030	10.8	30,700		
15.0	36.2	51,200	31.2	38,400	17.3	47,000		
18.0	43.3	61,430	37.5	46,100	—	—		

Shipping Damage

Upon receipt of equipment, the carton should be checked for external signs of shipping damage. If damage is found, the receiving party must contact the last carrier immediately, preferably in writing, requesting inspection by the carrier's agent.

General

The equipment covered in this manual is to be installed by trained, experienced service and installation technicians.

The refrigerant system is completely assembled and charged. All internal wiring is complete.

The unit is designed for use with or without duct work. Flanges are provided for attaching the supply and return ducts.

These instructions explain the recommended method to install the air cooled self-contained unit and the electrical wiring connections to the unit.

These instructions and any instructions packaged with any separate equipment required to make up the entire air conditioning system should be carefully read before beginning the installation. Note particularly "Starting Procedure" and any tags and/or labels attached to the equipment.

While these instructions are intended as a general recommended guide, they do not supersede any national and/or local codes in any way. Authorities having jurisdiction should be consulted before the installation is made. See Page 1 for information on codes and standards.

Size of unit for a proposed installation should be based on heat loss calculation made according to methods of Air Conditioning Contractors of America (ACCA). The air duct should be installed in accordance with the Standards of the National Fire Protection Association for the Installation of Air Conditioning and Ventilating Systems of Other Than Residence Type, NFPA No. 90A, and Residence Type Warm Air Heating and Air Conditioning Systems, NFPA No. 90B. Where local regulations are at a variance with instructions, installer should adhere to local codes.

Duct Work

Any heat pump is more critical of proper operating charge and an adequate duct system than a straight air conditioning unit. All duct work, supply and return, must be properly sized for the design air flow requirement of the equipment. Air Conditioning Contractors of America (ACCA) is an excellent guide to proper sizing. All duct work or portions thereof not in the conditioned space should be properly insulated in order to both conserve energy and prevent condensation or moisture damage.

Refer to Table 10 for maximum static pressure available for duct design.

Design the duct work according to methods given by the Air Conditioning Contractors of America (ACCA). When duct runs through unheated spaces, it should be insulated with a minimum of 1-inch of insulation. Use insulation with a vapor barrier on the outside of the insulation. Flexible joints should be used to connect the duct work to the equipment in order to keep the noise transmission to a minimum.

A 1/4-inch clearance to combustible material for the first three feet of duct attached to the outlet air frame is required. See Wall Mounting Instructions and Figures 3 and 4 for further details.

Ducts through the walls must be insulated and all joints taped or sealed to prevent air or moisture entering the wall cavity.



CAUTION

Some installations may not require any return air duct. A metallic return air grille is required with installations not requiring a return air duct. The spacing between louvers on the grille shall not be larger than 5/8 inches.

Any grille that meets the 5/8 inch louver criteria, may be used. It is recommended that Bard Return Air Grille Kit RG-2 thru RG-5 or RFG-2 thru RFG-5 be installed when no return duct is used. Contact distributor or factory for ordering information. If using a return air filter grille, filters must be of sufficient size to allow a maximum velocity of 400 fpm.

NOTE: If no return air duct is used, applicable installation codes may limit this cabinet to installation only in a single story structure.

Filters

A 1-inch throwaway filter is supplied with each unit. The filter slides into position making it easy to service. This filter can be serviced from the outside by removing the service door. A 1-inch washable filter and 2-inch pleated filter are also available as optional accessories. The internal filter brackets are adjustable to accommodate the 2-inch filter by bending down the tabs to allow spacing for the 2-inch filters.

Fresh Air Intake

All units are built with fresh air inlet slots punched in the service panel.

If the unit is equipped with the fresh air damper assembly, the assembly is shipped already attached to the unit. The damper blade is locked in the closed position to allow the damper to operate, the maximum and minimum blade position stops must be installed. See Figure 2.

All capacity, efficiency and cost of operation information as required for Department of Energy "Energyguide" Fact Sheets is based upon the fresh air blank-off plate in place and is recommended for maximum energy efficiency.

The blank-off plate is available upon request from the factory and is installed in place of the fresh air damper shipped with each unit.

Condensate Drain

A plastic drain hose extends from the drain pan at the top of the unit down to the unit base. There are openings in the unit base for the drain hose to pass through. In the event the drain hose is connected to a drain system of some type, it must be an open or vented type system to assure proper drainage.

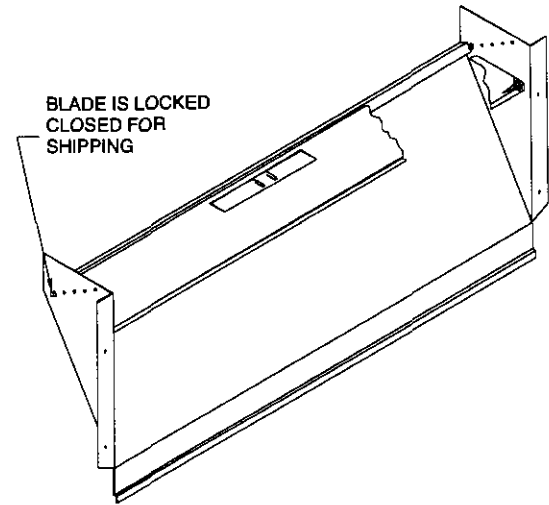

Figure 2 - Blower Damper Assembly

Installation Instructions

Wall Mounting Information

1. Two holes, for the supply and return air openings, must be cut through the wall as shown in Figure 3.
2. On wood-frame walls, the wall construction must be strong and rigid enough to carry the weight of the unit without transmitting any unit vibration. See Figures 4 and 5.



WARNING

Fire hazard can result if 1/4-inch clearance to combustible materials for supply air duct is not maintained. See Figure 3.

3. Concrete block walls must be thoroughly inspected to insure that they are capable of carrying the weight of the installing unit. See Figure 4.

Mounting the Unit

1. These units are secured by wall mounting brackets which secure the unit to the outside wall surface at both sides. A bottom mounting bracket is provided for ease of installation.
2. The unit itself is suitable for "0" inch clearance, but the supply air duct flange and the first 3 feet of supply air duct require a minimum of 1/4-inch clearance to combustible material. If a combustible wall, use a minimum of 30-1/2" x 10-1/2" dimensions for sizing. However, it is generally recommended that a 1-inch clearance is used for ease of installation and maintaining the required clearance to combustible material. The supply air opening would then be 32" x 12". See Figures 3, 4 and 7 for details.



WARNING

Failure to provide the 1/4-inch clearance between the supply duct and a combustible surface for the first 3 feet of duct can result in fire.

3. Locate and mark lag bolt locations and bottom mounting bracket location. See Figure 3.
4. Mount bottom mounting bracket.
5. Hook top rain flashing under back bend of top. Top rain flashing is shipped secured to the right side of the back.
6. Position unit in opening and secure with 5/16 lag bolts; use 7/8-inch diameter flat washers on the lag bolts.
7. Secure rain flashing to wall and caulk across entire length of top. See Figure 3.

8. For additional mounting rigidity, the return air and supply air frames or collars can be drilled and screwed or welded to the structural wall itself (depending upon wall construction). Be sure to observe required clearance if combustible wall.
9. On side by side installations, maintain a minimum of 20-inches clearance on right side to allow access to heat strips and control panel and to allow proper airflow to the outdoor coil. Additional clearance may be required to meet local or national codes.

Typical Installations

See Figure 6 for common ways to install the wall-mount unit.

Wiring — Main Power

Refer to the unit rating plate for wire sizing information and maximum fuse or "HACR Type" circuit breaker size. Each outdoor unit is marked with a "Minimum Circuit Ampacity". This means that the field wiring used must be sized to carry that amount of current. Depending on the installed KW of electric heat, there may be two field power circuits required. If this is the case, the unit serial plate will so indicate. All models are suitable only for connection with copper wire. Each unit and/or wiring diagram will be marked "Use Copper Conductors Only". These instructions **MUST BE** adhered to. Refer to the National Electrical Code (NEC) for complete current carrying capacity data on the various insulation grades of wiring material. All wiring must conform to NEC and all local codes.

The electrical data lists fuse and wire sizes (75°C copper) for all models, including the most commonly used heater sizes. Also shown are the number of field power circuits required for the various models with heaters.

The unit rating plate lists a "Maximum Time Delay Relay Fuse" or "HACR Type" circuit breaker that is to be used with the equipment. The correct size must be used for proper circuit protection and also to assure that there will be no nuisance tripping due to the momentary high starting current of the compressor motor.

The disconnect access door on this unit may be locked to prevent unauthorized access to the disconnect. To convert for the locking capability, bend the tab located in the bottom left hand corner of the disconnect opening under the disconnect access panel straight out. This tab will now line up with the slot in the door. When shut, a padlock may be placed through the hole in the tab preventing entry.

See Startup section for information on three phase scroll compressor startups.

Wiring — Low Voltage Wiring

230/208V, 1 phase and 3 phase equipment dual primary voltage transformers. All equipment leaves the factory wired on 240V tap. For 208V operation, reconnect from 240V to 208V tap. The acceptable operating voltage range for the 240 and 208V taps are:

Table 4 — Operating Voltage Range

TAP	RANGE
240V	253 - 216
208V	220 - 187

NOTE: The voltage should be measured at the field power connection point in the unit and while the unit is operating at full load (maximum amperage operating condition).

Five (5) wires should be run from thermostat subbase to the 24V terminal board in the unit. A five conductor, 18 gauge copper, color-coded thermostat cable is recommended. The connection points are shown in Figure 8.

Table 5 — Thermostat Wire Size

TRANSFORMER VA	FLA	WIRE GAUGE	MAXIMUM DISTANCE IN FEET
55	2.3	20 gauge	45
		18 gauge	60
		16 gauge	100
		14 gauge	160
		12 gauge	250

Table 6 — Wall Thermostat and Subbase Combinations

THERMOSTAT	SUBBASE	PREDOMINATE FEATURES
8403-002	8404-003	1 stage heat, 1 stage cool
T87F3111	Q539A1220	System: heat-off-cool Fan: auto-on
8403-009	—	1 stage heat, 1 stage cool
IF56-318	—	—
8403-019	8404-012	1 stage cool, 2 stage heat
8403-035	—	Programmable
1F95-80	—	—

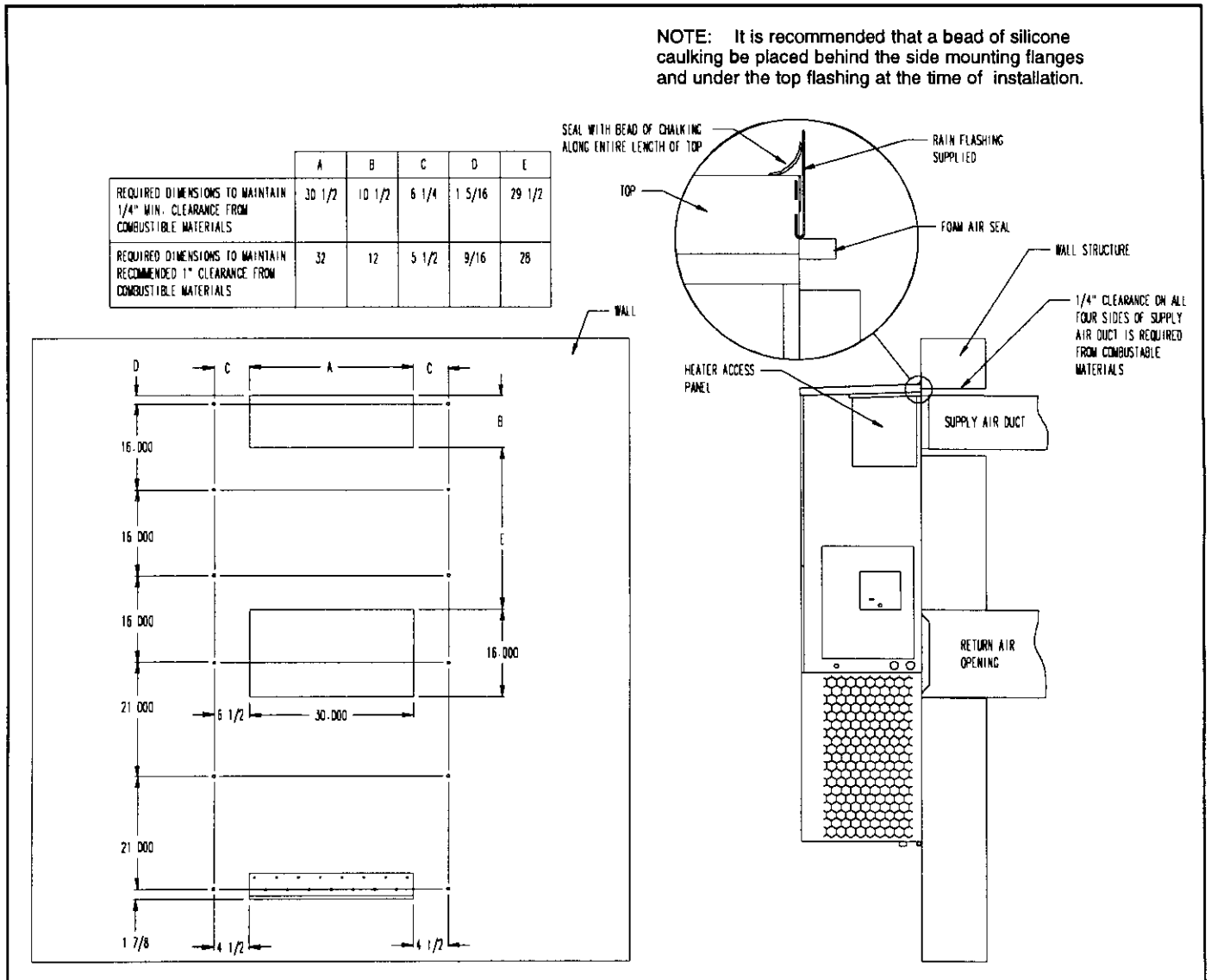
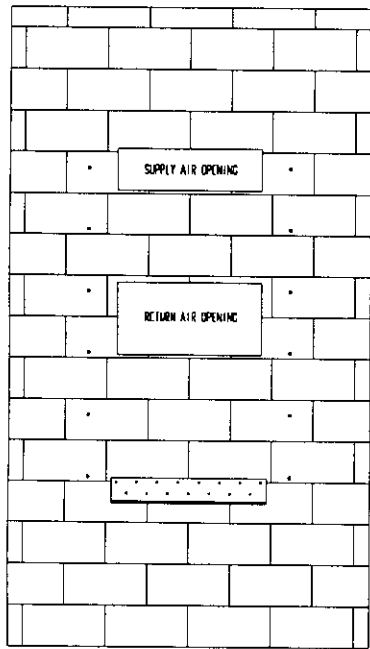
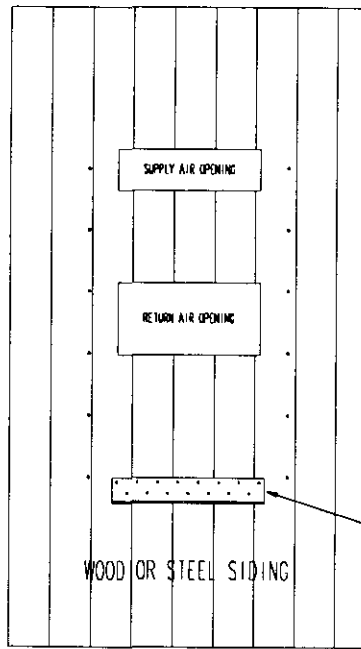

Figure 3 — Mounting Instructions

SEE FIGURE 3 — MOUNTING INSTRUCTIONS



CONCRETE BLOCK WALL INSTALLATION



WOOD FRAME WALL INSTALLATION

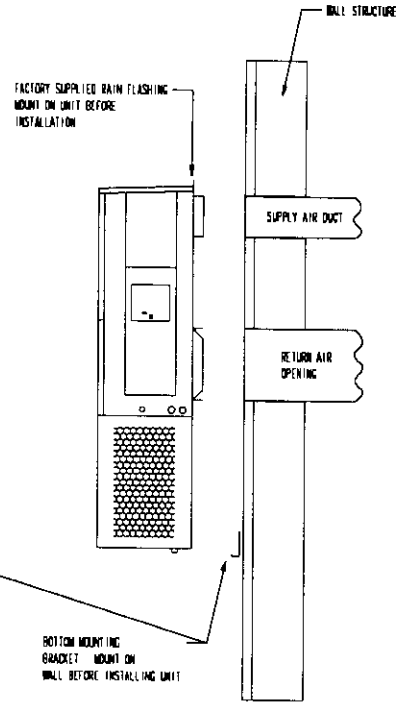

Figure 4 — Wall-Mounting Instructions

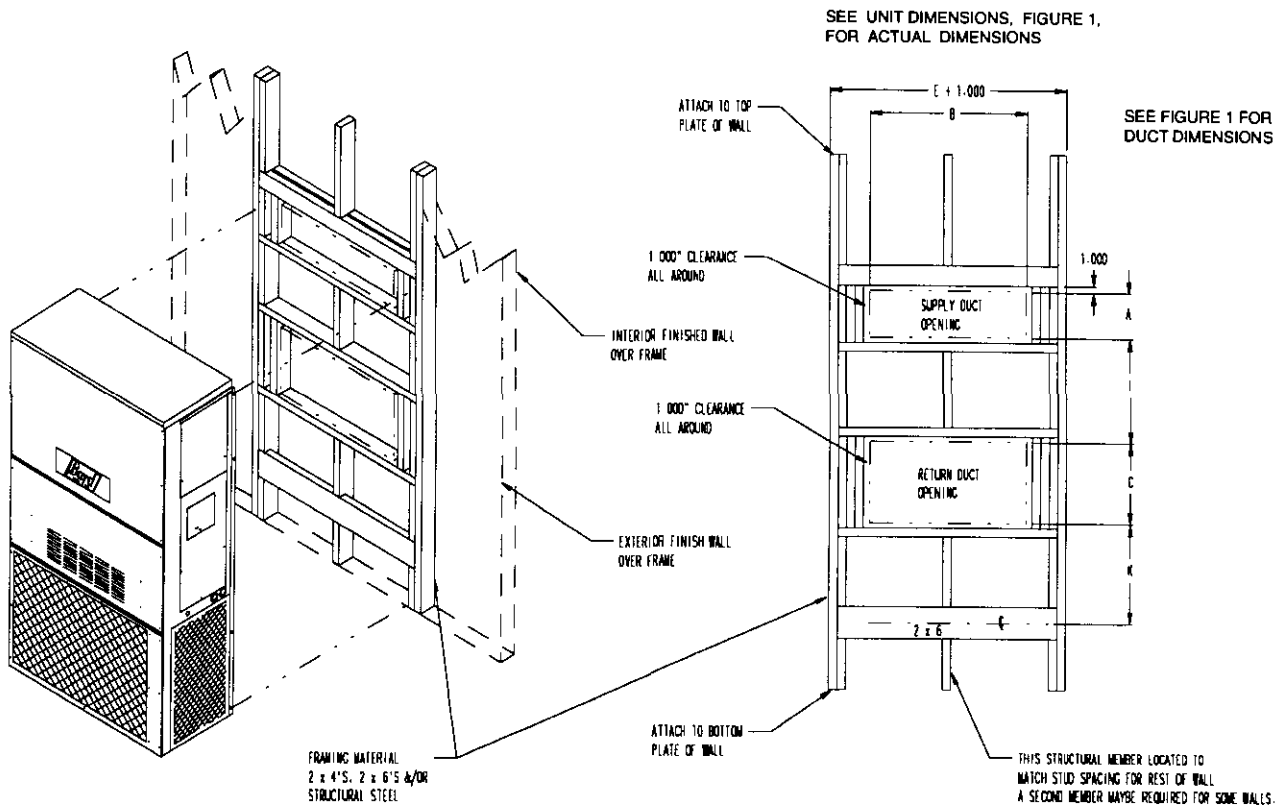
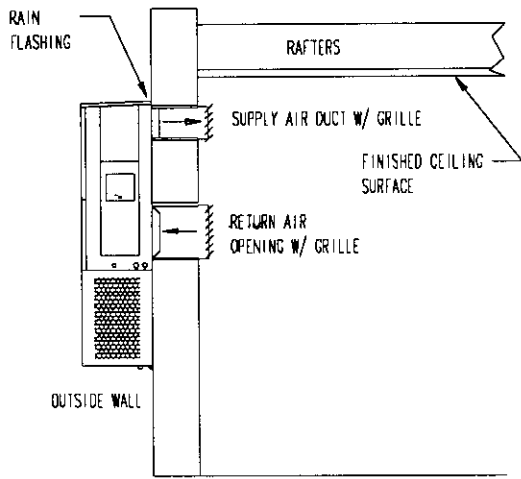
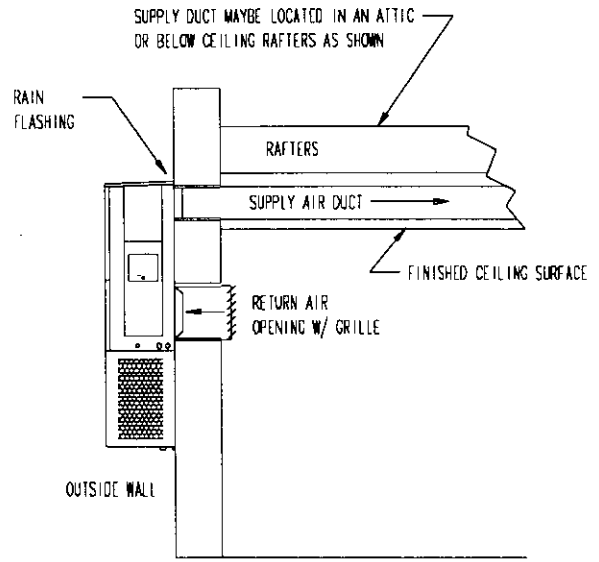

Figure 5 — Wall-Mounting Instructions



FREE AIR FLOW
NO DUCT



DUCTED SUPPLY
RETURN AT UNIT

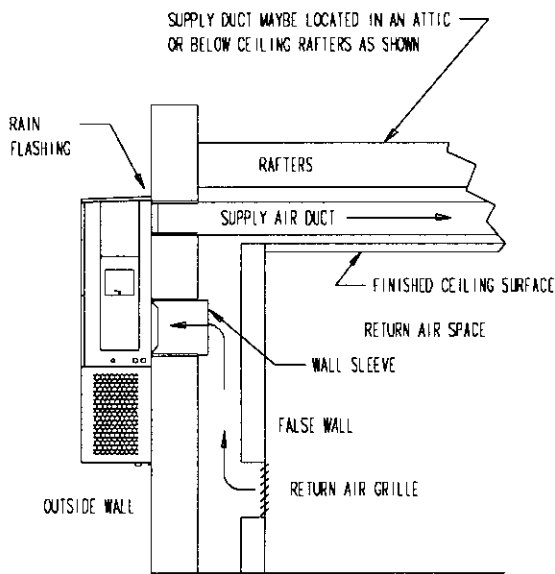

FALSE WALL INSTALLATION

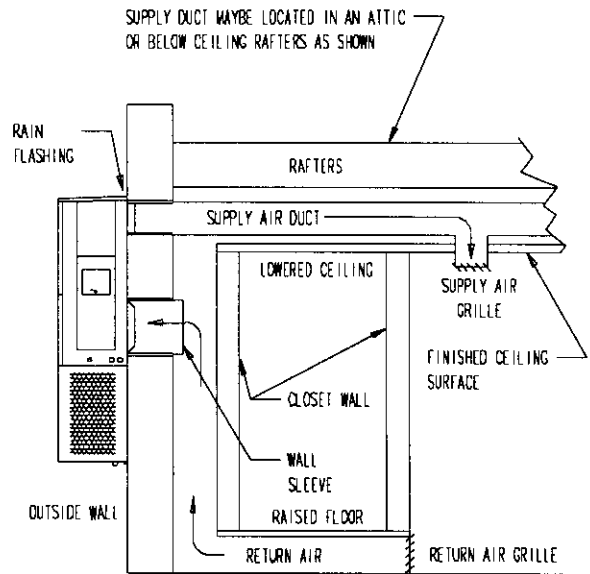

CLOSET INSTALLATION

Figure 6 — Common Wall-Mounting Installations

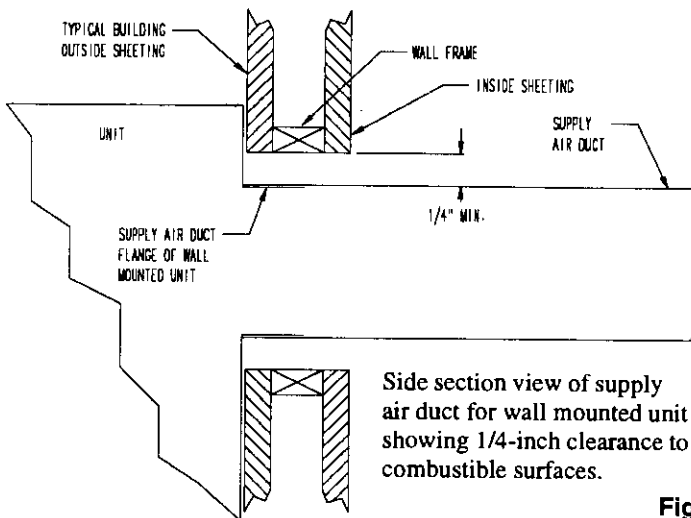

WARNING

- A minimum of 1/4-inch clearance must be maintained between the supply air duct and combustible materials. This is required for the first 3-feet of ducting.
- It is important to insure that the 1/4-inch minimum spacing is maintained at all points.
- Failure to do this could result in overheating the combustible material and may result in fire.

Figure 7 — Electric Heat Clearance

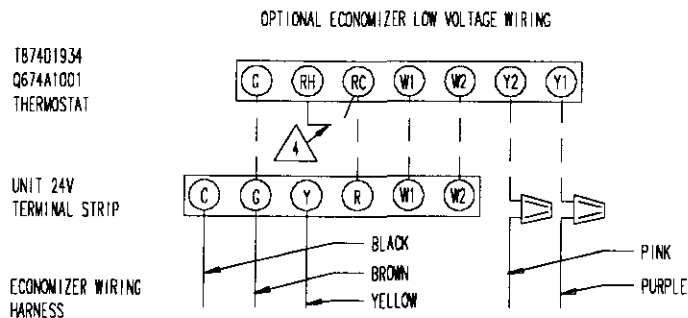
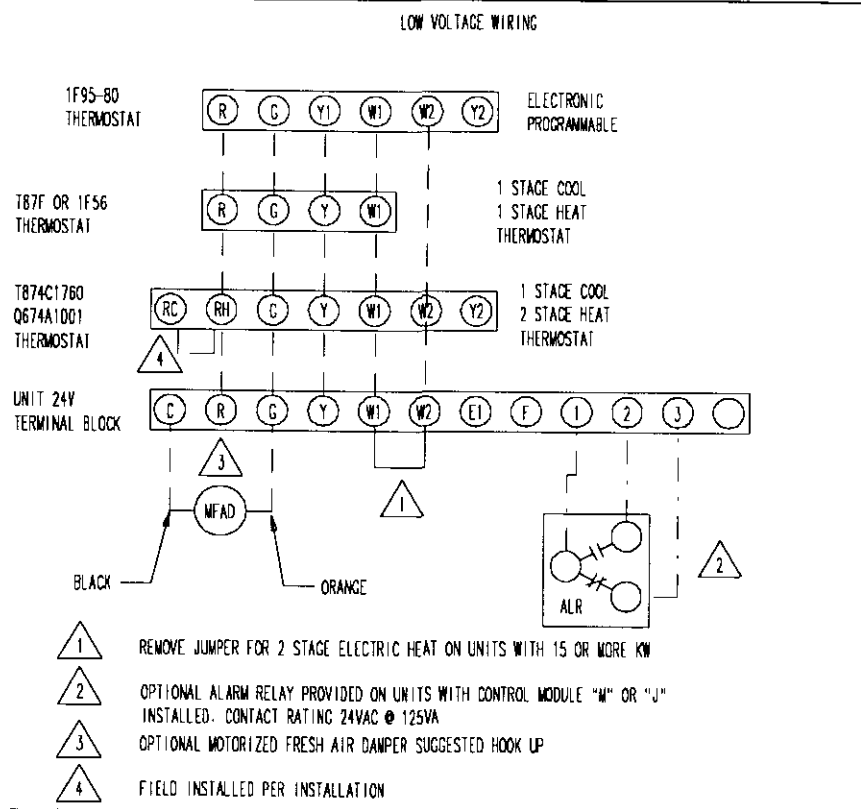

Figure 8 — Low Voltage Wiring

Start Up

Important Installer Note

For improved start-up performance, wash the indoor coil with a dishwasher detergent.

Crankcase Heaters

WA701 and WA721 units are provided with compressor crankcase heat.

The WA701 and WA721 models have a band type heater located around the bottom of the compressor. This heater is controlled by the crankcase heater relay. The heater is only energized when the compressor is not running.

Some form of crankcase heat is essential to prevent liquid refrigerant from migrating to the compressor, causing oil pump out on compressor start-up and possible valve failure due to compressing a liquid.

The decal in Figure 9 is affixed to all WA701 and WA721 units detailing start-up procedure. This is very important. Please read carefully.

Figure 9 — Start Up Label

IMPORTANT
These procedures must be followed at initial start-up and at any time power has been removed for 12 hours or longer.
To prevent compressor damage which may result from the presence of liquid refrigerant in the compressor crankcase.
1. Make certain the room thermostat is in the "off" position (the compressor is not to operate).
2. Apply power by closing the system disconnect switch. This energizes the compressor heater which evaporates the liquid refrigerant in the crankcase.
3. Allow 4 hours or 60 minutes per pound of refrigerant in the system as noted on the unit rating plate, whichever is greater.
4. After properly elapsed time, the thermostat may be set to operate the compressor.
5. Except as required for safety while servicing— <u>Do not open system disconnect switch.</u>
7961-061

High/Low Pressure Switch

The WA701 and WA721 models are supplied with a remote reset high pressure switch and low pressure switch. If tripped, this pressure switch may be reset by turning the thermostat off then back on again.

Three Phase Scroll Compressor Start Up Information

Scroll compressors, like several other types of compressors, will only compress in on rotational direction. Direction of rotation is

not an issue with single phase compressors since they will always start and run in the proper direction.

However, three phase compressors will rotate in either direction depending upon phasing of the power. Since there is a 50-50 chance of connecting power in such a way as to cause rotation in the reverse direction, verification of proper rotation must be made. Verification of proper rotation direction is made by observing that suction pressure drops and discharge pressure rises when the compressor is energized. Reverse rotation also results in an elevated sound level over that with correct rotation, as well as, substantially reduced current draw compared to tabulated values.

There is no negative impact on durability caused by operating three phase Compliant Scroll compressors in the reversed direction. However, after several minutes of operation, the compressor's internal protector will trip.

All three phase ZR3 compressors are wired identical internally. As a result, once the correct phasing is determined for a specific system or installation, connecting properly phased power leads to the same Fusite terminal should maintain proper rotation direction.

The direction of rotation of the motor may be changed by reversing any two line connections to the unit.

Service Hints

1. Caution homeowner to maintain clean air filters at all times. Also, not to needlessly close off supply and return air registers. This reduces air flow through the system, which shortens equipment service life as well as increasing operating costs.
2. Switching to heating cycle at 75°F or higher outside temperature may cause a nuisance trip of the remote reset high pressure switch. Turn thermostat off, then on to reset the high pressure switch.
3. Check all power fuses or circuit breakers to be sure they are the correct rating.
4. Periodic cleaning of the outdoor coil to permit full and unrestricted airflow circulation is essential.

Sequence of Operation

Cooling—Circuit R-Y makes at thermostat pulling in compressor contactor, starting the compressor and outdoor motor. The G (indoor motor) circuit is automatically completed on any call for cooling operation or can be energized by manual fan switch on subbase for constant air circulation. On a call for heating, circuit R-W1 make at the thermostat pulling in heat contact for the strip heat and blower operation. On a call for second stage heat, R-W2 makes bringing on second heat contactor, if so equipped.

Pressure Service Ports

High and low pressure service ports are installed on all units so that the system operating pressures can be observed. Pressure curves can be found later in the manual covering all models. It is imperative to match the correct pressure curve to the unit by model number.

Troubleshooting

Fan Blade Setting Dimensions

Shown in the drawing below are the correct fan blade setting dimensions for proper air delivery across the outdoor coil.

Any service work requiring removal or adjustment in the fan and/or motor area will require that the dimensions below be checked and blade adjusted in or out on the motor shaft accordingly.

Figure 10 - Fan Blade Setting

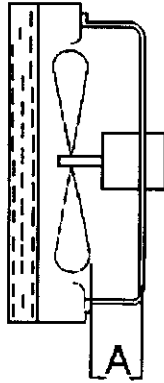

Table 7 — Fan Blade Dimensions

MODEL	DIMENSION A
WA721	.75
WA701	1.25

Removal of Fan Shroud

1. Disconnect all power to unit.
2. Remove the screws holding both grills — one on each side of unit — and remove grills.
3. Remove screws holding fan shroud to condenser and bottom — (9) screws.
4. Unwire condenser fan motor.
5. Slide complete motor, fan blade, and shroud assembly out the left side of the unit.
6. Service motor/fan as needed.
7. Reverse steps to reinstall.

Refrigerant Charge

The correct system R-22 charge is shown on the unit rating plate. Optimum unit performance will occur with a refrigerant charge resulting in a suction line temperature (6-inches from compressor) as shown in the following table:

Table 8 — Suction Line Temperatures

MODEL	RATED AIRFLOW	85°F	82°F
		OD TEMPERATURE	OD TEMPERATURE
WA701	1,800	58 - 60	56 - 58
WA721	1,650	59 - 61	57 - 59

The above suction line temperatures are based upon 80°F dry bulb/ 67°F wet bulb (50 percent R.H.) temperature and rated airflow across the evaporator during cooling cycle.

The suction line temperatures are based upon 80°F dry bulb 67°F wet bulb (50 percent relative humidity) temperature and rated airflow across the evaporator during cooling cycle.

Table 9 — Indoor Blower Performance — CFM at 230 Volts

E.S.P. In H ₂ O	WA701	
	WA721	
	HIGH SPEED DRY / WET COIL	LOW SPEED DRY / WET COIL
.0	2,200 / 2,000	1,600 / 1,450
.1	2,100 / 1,900	1,525 / 1,375
.2	2,000 / 1,800	— —
.3	1,875 / 1,700	— —
.4	1,775 / 1,600	— —
.5	1,650 / 1,475	— —

Table 10 — CFM and ESP

RATED MODEL	RATED CFM ①	RECOMMENDED ESP ①	AIRFLOW RANGE
WA701	1,650	.20	1,750 - 1,375
WA721	1,800	.10	2,000 - 1,475

① Rated CFM and ESP on high speed tap.

Table 11 — Maximum ESP of Operation Electric Heat Only

MODEL SPEED KW	WA701		WA721	
	LOW SPEED	HIGH SPEED	LOW SPEED	HIGH SPEED
-B00	.50	.50	.50	.50
-B09	.50	.50	.50	.50
-B15	.50	.50	.50	.50
-B18	.50	.50	.50	.50
-C09	.50	.50	.50	.50
-C15	.50	.50	.50	.50

Values shown are for units equipped with STD 1-inch throwaway filter or 1-inch washable filter. Derate ESP by .15 for 2-inch pleated filters.

Table 12 — Cooling Pressure

MODEL	RETURN AIR		75°	80°	82°	85°	90°	95°	100°	105°	110°	115°	120°	125°
	TEMPERATURE	PRESSURE												
WA701	75° DB	Low Side	62	63	63	64	65	66	67	68	69	70	—	—
	62° WB	High Side	214	230	236	247	265	280	299	316	333	351	—	—
	80° DB	Low Side	67	68	68	69	70	71	72	73	74	75	—	—
	67° WB	High Side	220	236	243	254	271	287	306	324	342	360	—	—
	85° DB	Low Side	72	73	73	74	75	76	77	78	79	80	—	—
	72° WB	High Side	225	243	250	261	279	297	316	335	353	372	—	—
WA721	75° DB	Low Side	63	64	64	65	66	67	68	69	70	71	72	73
	62° WB	High Side	205	222	228	237	254	268	286	302	318	336	348	360
	80° DB	Low Side	68	69	69	70	71	72	73	74	75	76	77	78
	67° WB	High Side	211	227	233	244	261	275	294	310	327	345	357	369
	85° DB	Low Side	73	74	74	75	76	77	78	79	80	81	82	83
	72° WB	High Side	216	234	240	251	268	285	303	321	339	357	370	383

Low side pressure ± 2 psig
High side pressure ± 5 psig

Tables are based upon rated CFM (airflow) across the evaporator coil. If there is any doubt as to correct operating charge being in the system, the charge should be removed, system evacuated and recharged to serial plate instructions.

Table 13 — Cooling Application Data — Outdoor Temperature °F ①

MODEL	② D.B./W.B.	COOLING CAPACITY	75°	80°	85°	90°	95°	100°	105°	110°	115°	120°	125°
	62°	Sensible Cooling	49,500	48,000	46,600	45,300	44,000	42,800	41,600	40,550	39,500	—	—
	80°	Total Cooling	74,550	72,850	71,050	69,100	67,000	64,800	62,400	59,900	57,250	—	—
	67°	Sensible Cooling	48,050	47,100	46,200	45,300	44,450	43,600	42,750	41,950	41,150	—	—
	85°	Total Cooling	88,700	85,100	81,550	77,950	74,400	70,800	67,250	63,650	60,100	—	—
	72°	Sensible Cooling	49,150	47,750	46,350	44,950	43,550	42,134	40,700	39,300	37,850	—	—
WA721	75°	Total Cooling	73,850	70,100	66,650	63,400	60,450	57,700	55,200	53,000	51,000	49,250	47,750
	62°	Sensible Cooling	52,250	51,200	50,150	49,000	47,800	46,550	45,250	43,850	42,450	41,000	39,450
	80°	Total Cooling	78,200	76,150	74,050	71,950	69,500	67,650	65,500	63,300	61,450	58,850	56,400
	67°	Sensible Cooling	51,100	50,400	49,650	48,900	48,250	47,250	46,350	45,400	44,200	43,400	42,400
	85°	Total Cooling	93,600	89,200	85,000	81,050	77,300	73,750	70,450	67,350	64,500	61,850	59,400
	72°	Sensible Cooling	51,950	50,950	49,850	48,650	47,300	45,800	44,200	42,500	40,650	38,650	36,500

① Below 65°F, unit requires a factory or field installed low ambient control.
② Return air temp. °F.

CAPACITY MULTIPLIER FACTORS			
% of Rated Air Flow	-10	Rated	+10
Total BTUH	0.975	1.0	1.02
Sensible BTUH	0.950	1.0	1.05

Table 14 — Optional Accessories

MODEL	DESCRIPTION	WA701-B	WA701-C	WA721-B
EHWA05-B09	Heater Packages	•		•
EHWA05-B15	Heater Packages	•		•
EHWA05-B18	Heater Packages	•		•
EHWA05A-C09	Heater Packages		•	
EHWA05A-C15	Heater Packages		•	
BOP-5	Blank Off Plate	•	•	•
BFAD-5	Barometric Fresh Air Damper	•	•	•
MFAD-5	Motorized Fresh Air Damper	•	•	•
CRV-5	Classroom Ventilator with Exhaust	•	•	•
EIFM-5	Economizer with Exhaust	•	•	•
WERV-A5A	Energy Recovery Ventilator	•		
WERV-C5A	Energy Recovery Ventilator		•	
WMPD-01C	Pull Disconnect Kit		•	

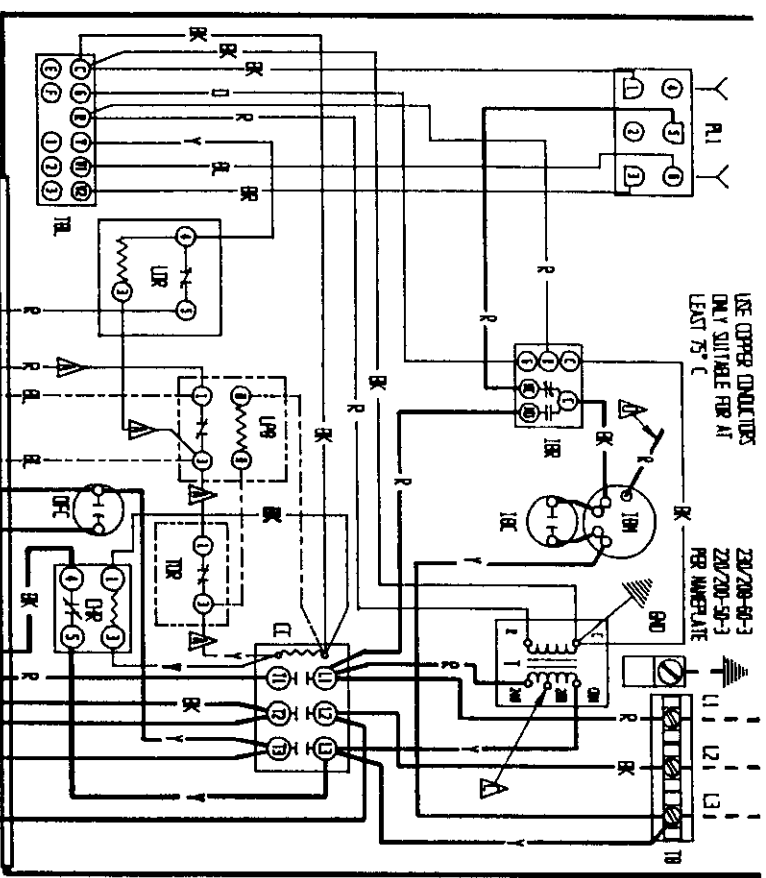

USE COPPER CONDUCTORS
ONLY SUITABLE FOR AT
LEAST 75° C

20/20-50-3
220/200-50-3
PER INGLEPLATE

20/20-50-3
220/200-50-3
PER INGLEPLATE

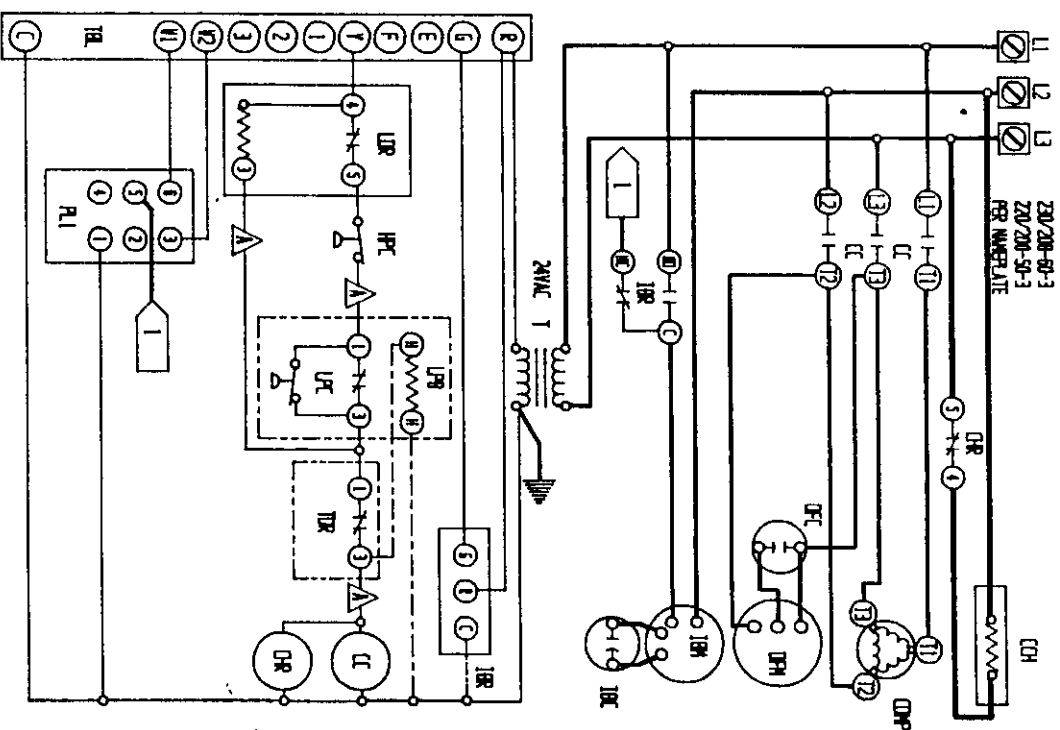

COMPONENT CODE	
CB1	CIRCUIT BREAKER #1
CB2	CIRCUIT BREAKER #2
CC	COMPRESSOR CONTACTOR
CH	CONDENSER FAN CONTACTOR
CH1	CONDENSER FAN CONTACTOR #1
CH2	CONDENSER FAN CONTACTOR #2
CH3	CONDENSER FAN CONTACTOR #3
CH4	CONDENSER FAN CONTACTOR #4
CH5	CONDENSER FAN CONTACTOR #5
CH6	CONDENSER FAN CONTACTOR #6
CH7	CONDENSER FAN CONTACTOR #7
CH8	CONDENSER FAN CONTACTOR #8
CH9	CONDENSER FAN CONTACTOR #9
CH10	CONDENSER FAN CONTACTOR #10
CH11	CONDENSER FAN CONTACTOR #11
CH12	CONDENSER FAN CONTACTOR #12
CH13	CONDENSER FAN CONTACTOR #13
CH14	CONDENSER FAN CONTACTOR #14
CH15	CONDENSER FAN CONTACTOR #15
CH16	CONDENSER FAN CONTACTOR #16
CH17	CONDENSER FAN CONTACTOR #17
CH18	CONDENSER FAN CONTACTOR #18
CH19	CONDENSER FAN CONTACTOR #19
CH20	CONDENSER FAN CONTACTOR #20
CH21	CONDENSER FAN CONTACTOR #21
CH22	CONDENSER FAN CONTACTOR #22
CH23	CONDENSER FAN CONTACTOR #23
CH24	CONDENSER FAN CONTACTOR #24
CH25	CONDENSER FAN CONTACTOR #25
CH26	CONDENSER FAN CONTACTOR #26
CH27	CONDENSER FAN CONTACTOR #27
CH28	CONDENSER FAN CONTACTOR #28
CH29	CONDENSER FAN CONTACTOR #29
CH30	CONDENSER FAN CONTACTOR #30
CH31	CONDENSER FAN CONTACTOR #31
CH32	CONDENSER FAN CONTACTOR #32
CH33	CONDENSER FAN CONTACTOR #33
CH34	CONDENSER FAN CONTACTOR #34
CH35	CONDENSER FAN CONTACTOR #35
CH36	CONDENSER FAN CONTACTOR #36
CH37	CONDENSER FAN CONTACTOR #37
CH38	CONDENSER FAN CONTACTOR #38
CH39	CONDENSER FAN CONTACTOR #39
CH40	CONDENSER FAN CONTACTOR #40
CH41	CONDENSER FAN CONTACTOR #41
CH42	CONDENSER FAN CONTACTOR #42
CH43	CONDENSER FAN CONTACTOR #43
CH44	CONDENSER FAN CONTACTOR #44
CH45	CONDENSER FAN CONTACTOR #45
CH46	CONDENSER FAN CONTACTOR #46
CH47	CONDENSER FAN CONTACTOR #47
CH48	CONDENSER FAN CONTACTOR #48
CH49	CONDENSER FAN CONTACTOR #49
CH50	CONDENSER FAN CONTACTOR #50
CH51	CONDENSER FAN CONTACTOR #51
CH52	CONDENSER FAN CONTACTOR #52
CH53	CONDENSER FAN CONTACTOR #53
CH54	CONDENSER FAN CONTACTOR #54
CH55	CONDENSER FAN CONTACTOR #55
CH56	CONDENSER FAN CONTACTOR #56
CH57	CONDENSER FAN CONTACTOR #57
CH58	CONDENSER FAN CONTACTOR #58
CH59	CONDENSER FAN CONTACTOR #59
CH60	CONDENSER FAN CONTACTOR #60
CH61	CONDENSER FAN CONTACTOR #61
CH62	CONDENSER FAN CONTACTOR #62
CH63	CONDENSER FAN CONTACTOR #63
CH64	CONDENSER FAN CONTACTOR #64
CH65	CONDENSER FAN CONTACTOR #65
CH66	CONDENSER FAN CONTACTOR #66
CH67	CONDENSER FAN CONTACTOR #67
CH68	CONDENSER FAN CONTACTOR #68
CH69	CONDENSER FAN CONTACTOR #69
CH70	CONDENSER FAN CONTACTOR #70
CH71	CONDENSER FAN CONTACTOR #71
CH72	CONDENSER FAN CONTACTOR #72
CH73	CONDENSER FAN CONTACTOR #73
CH74	CONDENSER FAN CONTACTOR #74
CH75	CONDENSER FAN CONTACTOR #75
CH76	CONDENSER FAN CONTACTOR #76
CH77	CONDENSER FAN CONTACTOR #77
CH78	CONDENSER FAN CONTACTOR #78
CH79	CONDENSER FAN CONTACTOR #79
CH80	CONDENSER FAN CONTACTOR #80
CH81	CONDENSER FAN CONTACTOR #81
CH82	CONDENSER FAN CONTACTOR #82
CH83	CONDENSER FAN CONTACTOR #83
CH84	CONDENSER FAN CONTACTOR #84
CH85	CONDENSER FAN CONTACTOR #85
CH86	CONDENSER FAN CONTACTOR #86
CH87	CONDENSER FAN CONTACTOR #87
CH88	CONDENSER FAN CONTACTOR #88
CH89	CONDENSER FAN CONTACTOR #89
CH90	CONDENSER FAN CONTACTOR #90
CH91	CONDENSER FAN CONTACTOR #91
CH92	CONDENSER FAN CONTACTOR #92
CH93	CONDENSER FAN CONTACTOR #93
CH94	CONDENSER FAN CONTACTOR #94
CH95	CONDENSER FAN CONTACTOR #95
CH96	CONDENSER FAN CONTACTOR #96
CH97	CONDENSER FAN CONTACTOR #97
CH98	CONDENSER FAN CONTACTOR #98
CH99	CONDENSER FAN CONTACTOR #99
CH100	CONDENSER FAN CONTACTOR #100

LABELLED WIRES CONNECT IF NO OPTIONS USED.		MOVE RED WIRE TO 200V TAP FOR 200V OPERATION		RED (LH) BLACK (HIGH)	
FACTORY SW.	FIELD	OPTIONAL			
HIGH VOLTAGE	LOW VOLTAGE	ACCESSORY			
BLACK	BROWN	RED	ORANGE	YELLOW	GREEN
GREEN	BLUE	WHITE		V	(FR)
RED	BLUE	WHITE		SV	(S)
YELLOW	PURPLE	SLATE		T	PK
PURPLE	SLATE			L	LAVENDER
SLATE					
RED (LH)	BLACK (HIGH)				
BARD WPC. CO.					
DN6, 4025-219 B					
DN1, DUDENE					
DN2, APR.					

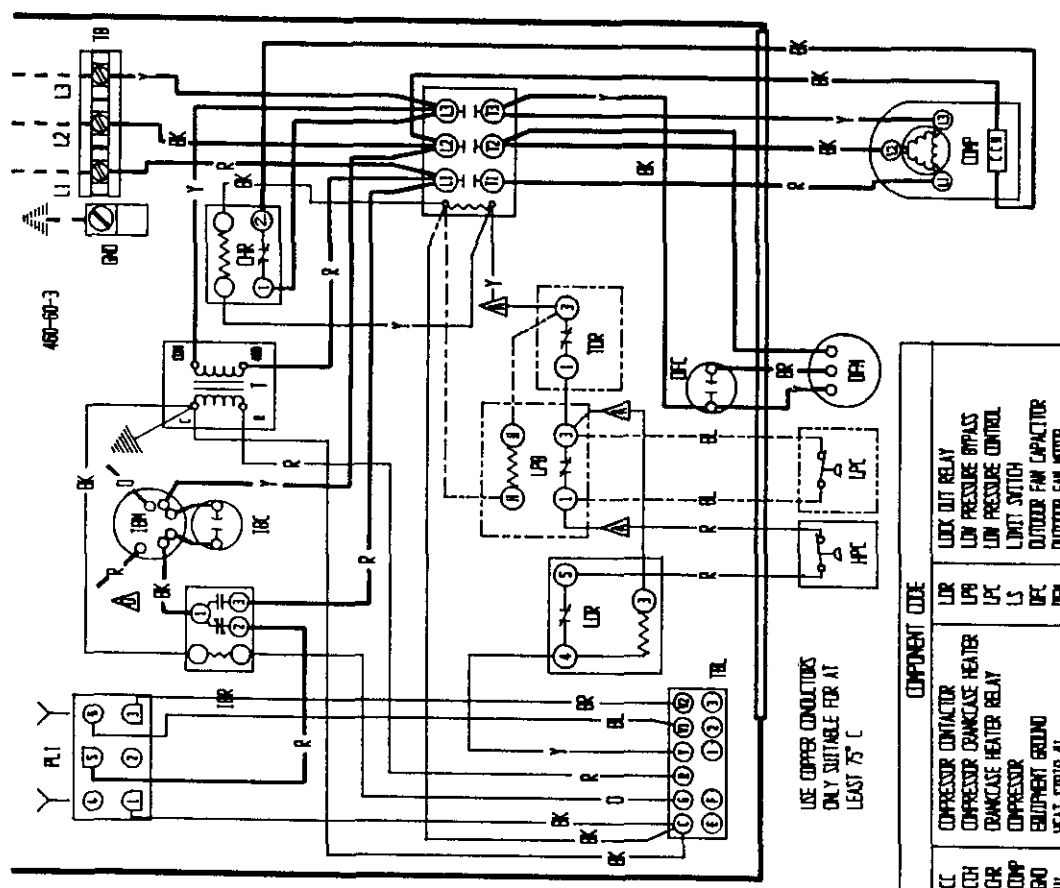
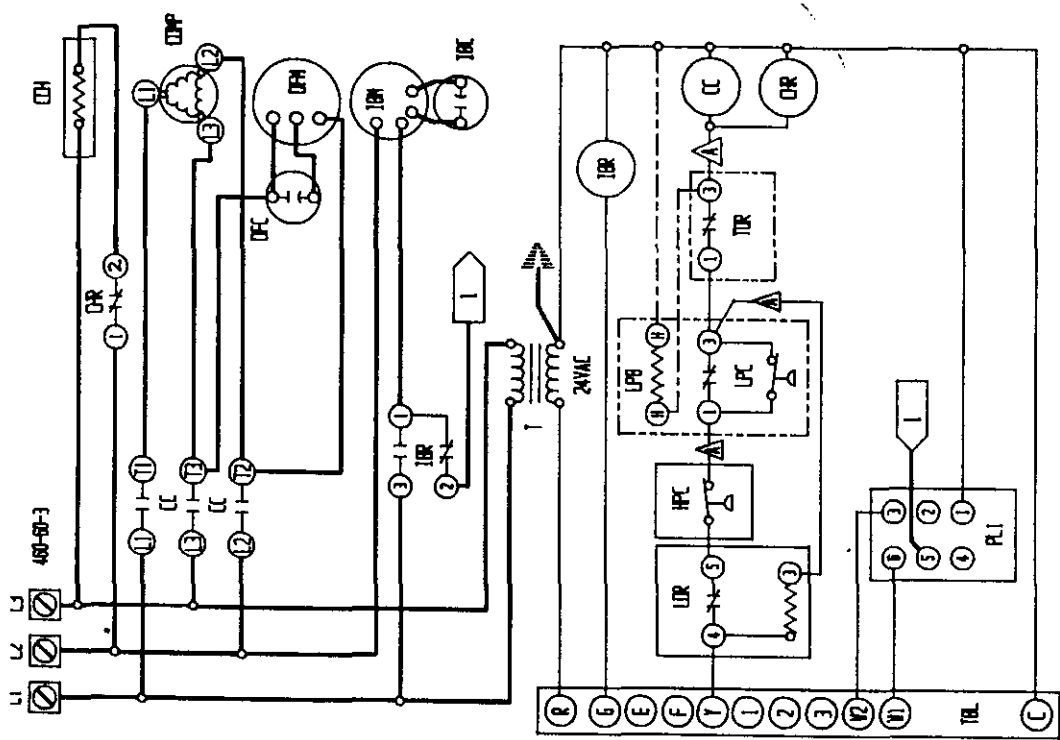

USE COPPER CONDUCTORS
ONLY SUITABLE FOR AT
LEAST 75°C

COMPONENT CODE	DESCRIPTION
CC	COMPRESSOR CONTACTOR
CH	COMPRESSOR CRANKCASE HEATER
CHR	CRANKCASE HEATER RELAY
COMP	COMPRESSOR
GRD	EQUIPMENT GROUND
H1	HEAT STRIP #1
H2	HEAT STRIP #2
HCF	HEATER CONTACTOR #1
HCF2	HEATER CONTACTOR #2
HP	HIGH PRESSURE CONTROL
IBR	INDOOR BLOWER CAPACITOR
IBM	INDOOR BLOWER MOTOR
IBR	INDOOR BLOWER RELAY
LUR	LOCK OUT RELAY
LUP	LOW PRESSURE BYPASS
LPC	LOW PRESSURE CONTROL
LS	LIMIT SWITCH
LFC	LOW VOLTAGE CAPACITOR
FAN	OUTDOOR FAN MOTOR
FD	PULL DISCONNECT
PL1	PLUS #1
TR	TRANSFORMER
Y	TERMINAL BLOCK
TRB	LOW VOLTAGE TERMINAL BLOCK
TRD	TERMINAL OFF
TRR	TIME DELAY RELAY

▲ LABELLED WIRES CONNECT IF NO OPTIONS USED.

▲ FOR LOW SPEED CONNECT BLACK AND ORANGE WIRES TOGETHER AND INSULATE. CONNECT RED WIRE TO TERMINAL 1 OF TR.

FACTORY STD.	FIELD	OPTIONAL	COLOR CODE
HIGH VOLTAGE	---	---	Y YELLOW
LOW VOLTAGE	---	---	G GREEN (FR)
NECESSARY	---	---	B BLUE
	---	---	W WHITE
	---	---	BL GRAY
	---	---	SL SLATE
	---	---	PK L
	---	---	PINK LAVENDER
	---	---	TAN

BARD VFC. CO.			
DRG.	4025-313 C		
DRM.	CR		
DRK.	AFR.		

