

INSTALLATION, OPERATION AND MAINTENANCE INSTRUCTIONS
UPFLOW/HORIZONTAL
OIL-FIRED
WARM AIR FURNACES
ISSUE 9413
SAVE THESE INSTRUCTIONS FOR FUTURE REFERENCE

AFFIX LABEL HERE

FUS 150 \$200

FOR YOUR SAFETY

DO NOT STORE OR USE GASOLINE OR OTHER FLAMMABLE VAPORS AND LIQUIDS IN THE VICINITY OF THIS OR ANY OTHER APPLIANCE.

DO NOT ATTEMPT TO START THE BURNER WHEN EXCESS OIL HAS ACCUMULATED, WHEN THE FURNACE IS FULL OF VAPOR OR WHEN THE COMBUSTION CHAMBER IS VERY HOT.

WARNING

For use with grade 2 Fuel Oil maximum. Do Not use Gasoline, Crankcase Oil or any Oil containing Gasoline!

CAUTION

Never burn garbage or paper in the heating system and never leave rags or paper around the unit.

CAUTION

These instructions are intended to be used by qualified personnel who have been trained in installing this type of furnace. Installation of this furnace by an unqualified person may lead to equipment damage and/or a hazardous condition which may lead to bodily harm.

GENERAL

This furnace is a three position unit, in that it may be operated in upflow, horizontal left-to-right, and horizontal right-to-left air flow positions. Very few modifications are required to change the furnace from one position to another at the job site. The furnace is shipped in the upflow configuration—instructions on changing to other configurations are on page 6 of this document.

It is shipped as a packaged unit, complete with burner and controls. It requires a line voltage (115VAC) connection to the control box, a thermostat hook-up as shown on the wiring diagram, oil line connection(s), adequate ductwork, and connection to a properly sized vent.

The air handling capacity of this furnace is designed for cooling air flow. Refer to Figure 6 for the expected airflows at various external duct static pressures.

IMPORTANT: All local and national code requirements governing the installation of oil burning equipment, wiring and flue connections must be followed. Some of the codes (issued by the Canadian Standards Association, the National Fire Protection Agency, and/or the American National Standards Institute) that may be applicable are:

CSA B139 INSTALLATION CODE FOR OIL
 BURNING EQUIPMENT
ANSI/NFPA 31 INSTALLATION OF OIL BURNING
 EQUIPMENT
ANSI/NFPA 90B WARM AIR HEATING AND AIR
 CONDITIONING SYSTEMS
ANSI/NFPA 211 CHIMNEYS, FIREPLACES, VENTS
 AND SOLID FUEL BURNING
 APPLIANCES
ANSI/NFPA 70 NATIONAL ELECTRICAL CODE
CSA C22.1 CANADIAN ELECTRICAL CODE

Only the latest issues of the above codes should be used, and are available from either:

The National Fire Protection Agency
Batterymarch Park
Quincy, MA 02269

or The Canadian Standards Association
 178 Rexdale Blvd.
 Rexdale, Ontario M9W 1R3

LOCATION

WARNING

This furnace is not watertight and is not designed for outdoor installation. This furnace shall be installed in such a manner as to protect the electrical components from water. Outdoor installation would lead to a hazardous electrical condition and to premature furnace failure.

CAUTION

For an attic installation it is important to keep insulation 12" or more away from any furnace openings. Some types of insulating materials may be combustible.

This furnace is approved for reduced clearances to combustible construction, therefore, it may be installed in an alcove or similar enclosure. It is also approved for

attic installation. As this unit may be installed as an upflow or horizontal furnace, it may be located in a basement, on the same level as the area to be heated, suspended, or in a crawlspace. In any case, the unit should always be installed level.

In a basement, or when installed on the floor (as in a crawlspace), it is recommended that the unit be installed on a concrete pad that is 1" to 2" thick.

When installed in a horizontal position, the furnace may be suspended by using an angle iron frame, as long as the total weight of both the furnace and the frame are allowed for in the support calculations. (Other methods of suspending are acceptable.)

The required minimum clearances for this furnace in all positions are specified in Figure 5.

The furnace should be located as close as possible to the chimney or vent in order to keep vent connections short and direct. The furnace should also be located as near as possible to the center of the air distribution system.

Air for Combustion and Ventilation:

This furnace should be installed in a location in which the facilities for ventilation permit satisfactory combustion of oil, proper venting and the maintenance of ambient temperature at safe limits under normal conditions of use. The location should not interfere with proper circulation of air within the confined space.

In addition to air needed for combustion, process air shall be provided as required for: cooling of equipment or material, controlling dew point, heating, drying, oxidation or dilution, safety exhaust and odor control.

In addition to air needed for combustion, air shall be supplied for ventilation, including all air required for comfort and proper working conditions for personnel.

The barometric draft regulator, included with the furnace, shall be installed in the same room or enclosure as the furnace in such a manner as to prevent any difference in pressure between the regulator and the combustion air supply.

Air requirements for the operation of exhaust fans, kitchen ventilation systems, clothes dryers, and fireplaces shall be considered in determining the adequacy of a space to provide combustion air requirements.

In unconfined spaces in buildings of conventional frame, brick or stone construction infiltration **MAY** be adequate to provide air for combustion, ventilation and dilution of flue gases. This determination must be made on an individual installation basis and must take into consideration the overall volume of the unconfined space, the number of windows and ventilation openings, the number of doors to the outside, internal doors which can close off the unconfined space and the overall tightness of the building construction.

Many new buildings and homes (and older ones that have been weatherized) must be considered as being tight construction and, therefore, infiltration will not be sufficient to supply the necessary air for combustion and ventilation.

A building can be considered as being of tight construction when:

- a. Walls and ceilings exposed to the outside atmosphere have a continuous water vapor retarder with a rating of one perm or less with openings gasketed or sealed and /or
- b. Weatherstripping has been added on operable windows and doors, and/or
- c. Caulking or sealants are applied to areas such as joints around window and door frames, between sole plates and floors, between wall-ceiling joints, between wall panels, at penetrations for plumbing, electrical and fuel lines and at other openings.

If combustion and ventilation air must be supplied to an unconfined space from outside, an opening with a free area of not less than one square inch per 1,000 BTU per hour of total input of all appliances within the unconfined space (but not less than 100 square inches) must be provided. This opening must be located such that it can not be blocked at any time.

For a confined space, where air is taken from an interior space, two permanent openings of equal area are required. One opening must be within 12" of the ceiling and the other within 12" of the floor. Each opening must have a free area of at least 1 sq. inch per 1,000 BTU of total input rating but no less than 100 sq. inches.

If outside air is supplied to a confined space, then the two openings must be equal and located as above and the free area of each must be:

1. 1 sq. inch per 4,000 BTU of total rating when the air is directly communicated from the outdoors.
2. 1 sq. inch per 4,000 BTU of total input rating when the air is brought in through vertical ducts.
3. 1 sq. inch per 2,000 BTU of total input rating when the air is transferred through horizontal ducts.

When ducts are used to supply air, they must be of the same cross sectional area as the free area of the openings to which they connect.

The minimum dimension of rectangular air ducts must not be less than 3 inches.

In calculating free area, consideration shall be given to the blocking effect of louvers, grilles or screens protecting openings. Screens used shall not be smaller than 1/4 inch mesh and shall be readily accessible for cleaning. If the free area through a design of louvered or grille is known, it shall be used in calculating the size design and free area specified. If the design and free area is not known, it may be assumed that wood louvers will have 20 percent free area and metal louvers and grilles will have 60 percent free area. Louvers shall be fixed in the open position or interlocked with the furnace so they are opened automatically at furnace start-up and remain open during furnace operation.

WARNING

Do not block the combustion air openings in the furnace. Any blockage will result in improper combustion ventilation which may result in a fire hazard and/or cause bodily harm.

Ductwork Recommendations:

The proper sizing of warm air ducts is necessary to insure satisfactory furnace operation. Ductwork should be in accordance with the latest editions of NFPA-90A (Installation of Air Conditioning and Ventilating Systems) and NFPA-90B (Warm Air Heating and Air Conditioning Systems) or Canadian equivalent.

The supply ductwork should be attached to the flanged opening provided at the discharge end of the furnace. See Figure 7 for the dimensions of this opening.

Knockouts are provided on both sides and the bottom of the furnace to facilitate locating the panel cut out required to connect to the return air ductwork. Only one opening should be used. An upflow installation may use any one of the openings, as appropriate. In a horizontal installation, we recommend the use of the bottom opening (although the side openings may be used, if necessary).

When the provided external filter rack is used, the return air duct should be attached as per Figure 9.

The following recommendations should be followed when installing the ductwork:

1. Install locking type dampers in all branches of the individual ducts to balance out the system. Dampers should be adjusted to impose the proper static at the outlet of the furnace.
2. A flexible duct connector of noncombustible material should be installed at the unit on both the supply and return air system. In applications where extremely quiet operation is necessary, the first 10 feet (if possible) of supply and return ducts should be internally lined with acoustical material.
3. In cases where the return air grille is located close to the fan inlet, there should be at least one 90° air turn between fan inlet and grille. Further reduction in sound level can be accomplished by installing acoustical air turning vanes or lining duct as described in item 2 above.
4. When a single air grille is used, the duct between grille and furnace must be the same size as return opening in furnace.

CAUTION

Return air grilles and warm air registers must not be obstructed.

WARNING

When supply ducts carry air circulated by the furnace to areas outside the spaces containing the furnace, the return air shall also be handled by a duct sealed to the furnace casing and terminating outside the space containing the furnace. Incorrect ductwork termination and sealing will create a hazardous condition which could lead to bodily harm.

When installing the furnace with cooling equipment for year round operation, the following recommendations must be followed for series or parallel air flow:

1. In series air flow applications, the coil is mounted after the furnace in an enclosure in the supply air stream. The furnace blower is used for both heating and cooling air flow.

WARNING

The coil **MUST** be installed on the air discharge side of the furnace. Under no circumstances should the air flow be such that cooled, conditioned air can pass over the furnace heat exchanger. This will cause condensation in the heat exchanger and possible failure of the heat exchanger which could lead to a fire hazard and/or a hazardous condition which may lead to bodily harm. Heat exchanger failure due to improper installation may not be covered by warranty.

2. In parallel flow installation, dampers must be provided to direct air over the furnace heat exchanger when heat is desired and over the cooling coil when cooling is desired.

IMPORTANT: The dampers should be adequate to prevent cooled air from entering the furnace, and if manually operated, must be equipped with the means to prevent operation of either the cooling unit or furnace unless the damper is in the full cool or heat position.

Venting Instructions:

Venting of the furnace should be to the outside and in accordance with local codes or requirements of the local utility.

OIL FIRED APPLIANCES SHALL BE CONNECTED TO FLUES HAVING SUFFICIENT DRAFT AT ALL TIMES TO ENSURE SAFE AND PROPER OPERATION OF APPLIANCE.

For additional venting information refer to ANSI/NFPA 211 Chimney, Fireplaces, Vents and Solid Fuel Burning Appliances and/or CSA B139 Installation Code.

This furnace is certified for use with Type "L" vent (maximum flue gas temperature 575°F).

Pre-Installation Vent System Inspection:

Before this furnace is installed, it is highly recommended that any existing vent system be completely inspected.

For any chimney or vent, this should include the following:

1. Inspection for any deterioration in the chimney or vent. If deterioration is discovered, the chimney must be repaired or the vent must be replaced.
2. Inspection to ascertain that the vent system is clear and free of obstructions. Any blockage must be cleared before installing this furnace.
3. Cleaning the chimney or vent if previously used for venting a solid fuel burning appliance or fireplace.
4. Confirming that all unused chimney or vent connections are properly sealed.
5. Verification that the chimney is properly lined and sized per the applicable codes. (Refer to list of codes on page 2.)

Masonry Chimney:

This furnace can be vented into an existing masonry chimney. This furnace must not be vented into a chimney servicing a solid fuel burning appliance. Before venting this furnace into a chimney, the chimney **MUST** be checked for deterioration and repaired if necessary. The chimney must be properly lined and sized per local or national codes.

If the furnace is vented into a common chimney, the chimney must be of sufficient area to accommodate the total flue products of all appliances vented into the chimney.

The following requirements are provided for a safe venting system:

1. Be sure that the chimney flue is clear of any dirt or debris.
2. Be sure that the chimney is not servicing an open fireplace.
3. Never reduce the pipe size below the size of the furnace flue pipe.
4. All pipe should be supported using the proper clamps and/or straps. These supports should be at least every four (4) feet.
5. All horizontal runs of pipe should have at least a 1/4" per foot of upward slope.
6. All runs of pipe should be as short as possible with as few turns as possible.
7. Seams should be tightly joined and checked for leaks.
8. The flue pipe must not extend into the chimney but be flush with the inside wall.

9. The chimney must extend three (3) feet above the highest point where it passes through a roof of a building and at least two (2) feet higher than any portion of a building within a horizontal distance of ten (10) feet. It shall also be extended at least five (5) feet above the highest connected equipment flue collar.
10. Check local codes for any variance.

Factory Built Chimneys:

May use listed factory built chimneys. Refer to chimney manufacturers instructions for proper installation.

Horizontal Venting:

This furnace may be horizontally vented through an outside wall when installed with the following auxiliary inducer blower:

available from: Tjernlund Products, Inc. Model SS1C

Tjernlund Products, Inc.
1601 Ninth Street
White Bear Lake, MN 55110-6795

NOTE: An isolation relay should be used to allow proper operation of the ignition control with the auxiliary blower. Instructions for connecting the relay are included in the Tjernlund blower.

CAUTION
USE METALLIC VENT PIPE, ONLY! PLASTIC
VENTING MATERIALS ARE PROHIBITED!

Oil Burner:

This furnace is supplied with a high pressure atomizing retention head type burner (for use with not heavier than grade 2 Fuel Oil). The air tube length, from the face of the mounting plate to the extreme face of the end cone, should be seven (7) inches.

Lubricate the burner motor with SAE 10 oil. Once each year, pour two (2) teaspoons of oil slowly into each oil cup.

Oil Connections:

Complete instructions for installation of the fuel oil piping will be found in the oil burner installation instructions included with the furnace.

Oil line entry holes are produced in the side panels and top panel. Two holes are provided in each location, so that a two-pipe system may be used if desired. See Figure 1 below.

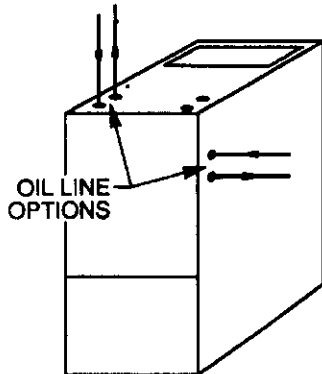

Oil Connection Entry Holes

Figure 1

An oil filter should be used with all oil burners, installed as close as possible to the burner.

Barometric Draft Control:

The barometric draft control shipped with the furnace must be used with the furnace to insure proper operation. Instructions for installing the control are packed with the control. Refer also to Figure 8 on page 14 for suggested locations.

Electrical:

The appliance must be installed in accordance with current ANSI/NFPA 70 National Electrical Code, CSA C22.1 Canadian Electrical Code Part 1 and/or local codes.

The control system depends on the correct polarity of the power supply. Connect "HOT" wire (H) and "NEUTRAL" wire (N) as shown in Figure 10.

A separate line voltage supply should be used with a fused disconnect switch or circuit breaker between the main power panel and the unit. See Figure 10.

WARNING

The unit cabinet must have an uninterrupted or unbroken electrical ground to minimize personal injury if an electrical fault should occur. A green ground screw is provided in the control box for this connection.

Use copper wire only for 115V supply service to unit.

Metallic conduit (where required/used) may terminate at the side panel of the unit. It is not necessary to extend the conduit inside the unit from the side panel to the control box.

When replacing any original furnace wiring, use only 105 degree C, 16 AWG copper wire.

Instructions for wiring the thermostat are packed in the thermostat (field supplied) box. Make the thermostat connections as shown in Figure 10 at the 24 volt terminal board on the control box.

When installing optional accessories to this appliance, follow the manufacturer's installation instructions included with the accessory. Other than wiring for the thermostat, wire with a minimum of type "T" insulation (63°F rise) must be used for accessories.

Filters:

An external filter rack is provided as standard equipment with this furnace. The assembly and installation of this filter rack is shown in Figure 9.

To Change from Upflow to Horizontal:

- Remove the burner from the unit by removing the three burner mounting nuts. Prevent putting undue strain on burner wiring. (It may be necessary to disconnect the burner wiring in some cases.)
- Note that the three burner mounting studs are in the "nine, twelve, and three" o'clock positions on the burner mounting plate.
- Place the furnace in the installation position (i.e., on its side). Remove the burner mounting stud that is now in the six o'clock position (See Illustrations A & B). Reinstall the stud in the other open position on the mounting plate, so that

once again there are studs in the nine, twelve, and three o'clock positions. It may be necessary to use two of the burner mounting nuts as "Jam Nuts" on the stud in order to provide a means of using a wrench to remove a tight stud.

- Reinstall the burner, insuring that all three burner mounting nuts are tight. **IMPORTANT:** Burner must always be installed in the upright position with the ignition control on top.

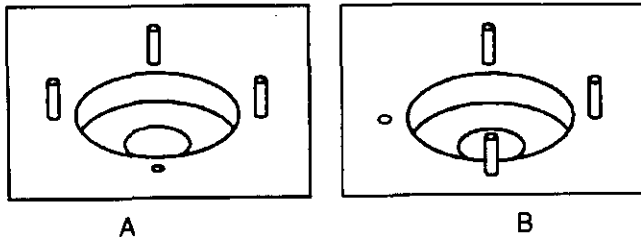

(ILLUSTRATIONS A & B)

WARNING

Do not use this furnace as a construction heater. Use of this furnace as a construction heater exposes the furnace to abnormal conditions, contaminated combustion air and the lack of air filters. Failure to follow this warning can lead to premature furnace failure and/or vent failure which could result in a fire hazard and/or bodily harm.

WARNING

Installation of this furnace in an area where it will receive contaminated combustion air must be avoided. Such contamination would include the following: ammonia, chlorine, hydrogen sulfide, halogenated hydrocarbons, carbon tetrachloride, cleaning solvents, hydrochloric acid, water softening chemicals and other similar chemicals. Failure to follow this warning will lead to premature rusting of the heat exchanger and possible premature furnace failure and/or vent failure which could result in a fire hazard and/or bodily harm.

Operational Checkout:

DO NOT START THE BURNER UNLESS THE BLOWER ACCESS DOOR IS SECURED IN PLACE.

The installation of the furnace is now complete and the operational checkout may be performed.

START-UP:

1. Check the wiring against the diagram in Figure 10.
2. Open the valve on the oil supply line.
3. Reset the primary control.
4. Set the thermostat above room temperature.
5. Set the main electrical switch to "ON" position and the burner should start.

DO NOT TAMPER WITH THE UNIT OR CONTROLS - CALL YOUR SERVICEMAN.

Recommended Installation Practices and Combustion Check:

In order to obtain the optimum performance from the oil burner, the following set-up procedures must be followed:

1. A test kit (Bacharach No. 5022 kit or equivalent) to measure the smoke, stack draft, over-fire draft, CO₂, and stack temperatures **MUST** be used in order to obtain the proper air band setting. Although all of the above measurements are required for optimum set up and efficiency data, the most important readings that must be taken are the smoke number, over the fire draft and stack draft.
2. The proper smoke number has been established by engineering tests to be between 0 & 1. This degree of smoke emission is commonly referred to as a "Trace" of smoke. It is recommended to use a Bacharach true spot smoke test set or equivalent.
3. In order to ensure the proper draft through the furnace, a barometric draft regulator, which is supplied with the furnace, must be installed as close to the outlet of the furnace as possible. In order for this device to function properly, the barometric damper must be mounted with the hinge pins horizontal and the face of the damper vertical (see instructions included with damper). The draft regulator should be adjusted after the furnace has been firing for at least five minutes and the stack draft should be measured and set between $-.025''$ wc and $-.035''$ wc. The draft should be checked with a Bacharach MZF draft gauge or equivalent.

4. The over the fire draft, which is taken through the hole that is provided in the observation door, is a measurement that is necessary to determine if there is a blockage between the oil burner and the flue outlet.
There should be between a .005"wc to .020"wc pressure drop through the furnace. This would set the range of the over the fire draft between -.01"wc to -.03"wc. A reading above -.01"wc, for example +0.1"wc, would indicate that the furnace is in an extremely high pressure condition in the primary section. This condition may be caused by excessive combustion air due to the air band being too wide open or a lack of flue draft (chimney effect) or some other blockage, such as soot, in the secondary section of the heat exchanger.
5. The CO₂ and stack temperature instruments will enable you to obtain the data that is required to determine the thermal efficiency of the furnace.
6. An oil filter should be installed as close to the burner as possible with all oil burners and is essential on the lower firing rate burners. We recommend the use of a low pressure drop oil filter such as the General Filter, Inc. model #1A-25A or equivalent. It is critical that the oil capacity be equivalent or greater than the fuel pump gear capacity. For a two pipe system this is 25gph.
7. The oil pressure regulator is factory set to give nozzle oil pressures of 100PSIG. The firing

rate noted on the nameplate may be obtained with "standard" nozzles by adjusting the pump pressure as noted on the chart below or noted on the label on the furnace.

NOTE: This appliance is equipped with one of the oil burners as listed on the chart below and rating label on the furnace. Use the nozzle listed for that specific oil burner.

On a new installation the air entrapped in the oil line leading from the tank to the nozzle must be thoroughly purged in order to prevent excessive after drip. The oil pump is provided with a special fitting that will enable you to purge any air between the tank and oil pump. The proper procedure for performing this operation is as follows:

Place a piece of clear plastic 1/4" dia. tubing over the purge fitting on the oil pump. Start the oil burner, then open the purge fitting and allow the burner to run until the purge tube is completely free of air bubbles. At this point tighten the purge fitting which will allow the oil to run to the nozzle and fire the burner. (If the purging takes longer than 15 seconds and no flame has been established the burner will stop. Push the reset button on top of Primary Control to restart burner.) For detailed information on operation of primary control refer to instructions included with furnace.

8. After all the set up procedures mentioned above have been completed, the burner should be allowed to operate and an inspection mirror should be used to observe the flame pattern. Any irregularities such as burning to one side or pulsating flame patterns should be corrected by changing the nozzle.

BURNER, NOZZLE AND PUMP PRESSURE CHART

HEATING CAPACITY BTU/HR.	FIRING RATE GAL/HR/(US)	PUMP PRESSURE PSIG	DUCANE OIL BURNER		R.W. BECKETT OIL BURNER	
			MODEL	NOZZLE	MODEL	NOZZLE
150,000	1.35	100	DRC-20A	1.35 GPH 80" SOLID	AFG	1.35 GPH 70" SOLID
200,000	1.75	100	DRC-20A	1.75 GPH 80" SOLID	AFG	1.75 GPH 70" SOLID

Fan Adjustment Check:

This furnace is equipped with a 3 speed direct drive motor to deliver a temperature rise within the range specified on the rating plate, between the return and supply plenums, at the external duct static pressure noted on the rating label.

Adjust the fan speed so that the temperature rise is within the rise specified on the rating plate. Consult the wiring diagram for speed changes on the direct drive motor.

To adjust fan OFF time, set the DIP switches on the control board as shown to obtain the desired timing (See Figure 2 on next page).

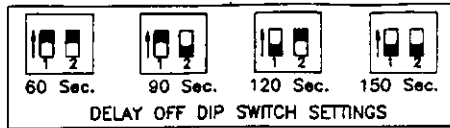

Figure 2

Limit Control Check:

After the furnace has been in operation for at least 15 minutes, restrict the return air supply by blocking the filters or closing the return registers and allow the furnace to shut down on high limit. The burner will shut OFF and the main blower should continue to run.

Remove the restriction and the burner should come back on in a few minutes.

For Year Round Air Conditioning:

The furnace is designed for use in conjunction with cooling equipment to provide year round air conditioning. The blower has been sized for both heating and cooling, however, the fan motor speed may need to be changed to obtain the necessary cooling air flow.

Heating:

The blower speed is factory set to deliver the required air flow at normal duct static pressure.

Cooling:

The blower speed may be adjusted in the field to deliver the required air flow, for cooling application, as outlined in Figure 6.

Constant Blower Switch:

This furnace is equipped with a constant low speed blower option. Whenever the room thermostat is not calling for heating or cooling, the blower will run on low speed in order to provide air circulation. If this constant blower option is not desired, the rocker switch on the side of the control box may be used to "turn off" the constant speed.

MAINTENANCE

This furnace should never be operated without an air filter. Filters should be cleaned at least twice a year.

To avoid personal injury, make sure the electrical supply power is "OFF" before servicing.

ALWAYS KEEP THE MAIN OIL VALVE TURNED OFF, IF THE BURNER IS SHUT DOWN FOR AN EXTENDED PERIOD OF TIME.

WARNING

Before performing any service functions, unless operations specifically require the power to be on, make sure all utilities are turned "OFF" upstream of the appliance. Failure to comply with this warning will cause a fire hazard and/or bodily harm.

Periodic oiling of the blower motor may be necessary. Check for instructions on the inside of your blower compartment door.

To maintain proper performance, the oil burner nozzle must be replaced once a year. Contact your dealer serviceman if you are unsure of this procedure.

The procedure for nozzle installation and/or replacement is outlined in the oil burner instruction manual which came with the furnace. For ease of maintenance, the oiling procedure for the burner motor, as outlined in the burner manual, should be performed at this time.

After replacement of the nozzle, the burner should be adjusted in accordance with the "**COMBUSTION CHECK**" section of the instruction.

Ordinarily, it is not necessary to clean the heat exchanger or flue pipe every year, but it is necessary to have your oil burner serviceman check the unit before each heating season to determine whether cleaning or replacement of parts is required.

If cleaning is necessary, the following steps should be performed:

1. Turn "**OFF**" all utilities upstream of the furnace.
2. Disconnect the flue pipe.
3. Remove the collar on the flue connection.

4. Remove the upper rear panel.
5. Remove the flue collector box from the secondary heat exchanger tube flange. This exposes the inside surfaces of the secondary tubes of the heat exchanger. If only the secondary needs to be cleaned, no further disassembly is required.

6. Clean the secondary tubes and flue pipe with a stiff brush and vacuum cleaner.

If the primary heat exchanger section is also to be cleaned:

7. Disconnect the limit control wires
8. Disconnect the oil line and remove the oil burner from the furnace.
9. Remove the observation door.
10. Remove the collar on the observation tube.
11. Remove the intermediate panel. (Care must be taken not to bend or damage the limit control.)
12. Loosen to hand tightness the three (3) nuts labeled "A" in Figure 3. Remove the screws labeled "B" in Figure 3. Slide the combustion chamber forward, out of the heat exchanger. Be careful not to bump the combustion chamber as it becomes brittle after having been fired.

13. Again, use a stiff brush and vacuum cleaner to clean the inside of the primary drum.

CAUTION

Never use incendiary type cleaners (smoke sticks) for cleaning!!

14. Before reassembly, the heat exchanger and combustion chamber should be inspected to determine if replacement is required. After cleaning, place combustion chamber back into primary drum and secure with the "B" screws--insure that the cover plate gasket is in place before tightening the screws. (Care must be taken not to damage the combustion chamber.)

15. Tighten the "A" nuts to 30 pound-inches of torque (firm, but not overly tight).

16. Replace the intermediate panel, observation tube collar, observation door, limit wiring, and oil burner.

17. Replace the collector box on the secondary tube flange, insuring proper placement of the gasket. **If gasket is damaged in any way, it should be replaced!** Tighten the screws to 30 pound-inches of torque.

18. Replace the upper rear panel and flue collar.

19. Reconnect the flue pipe and oil pipe(s).

20. Readjust burner for proper operation. Check limit operation as outlined in this manual.

COMBUSTION CHAMBER REMOVAL

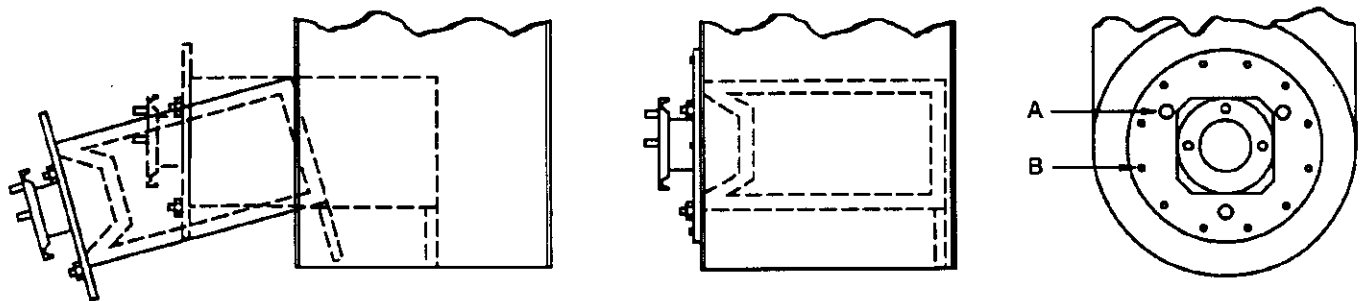

Figure 3

BLOWER REMOVAL

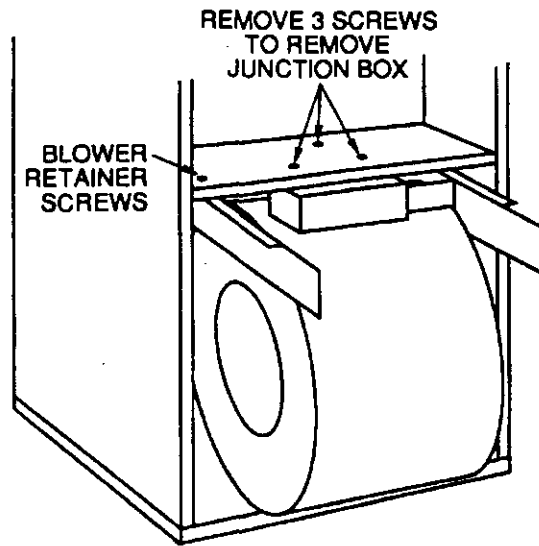

Figure 4

Blower Removal (Refer to Figure 4):

To remove the blower from the furnace:

1. Turn "OFF" all utilities upstream of the furnace.
2. Remove the louvered door and blower door.
3. Remove the blower retaining screw (on the blower partition panel, near the corner where the intermediate panel and blower partition meet).
4. Remove cover from control box and disconnect the thermostat and power wires from the board.
5. Remove the three (3) screws holding control box to the blower partition.
6. Slide the blower forward on the rails toward the front of the unit until the motor wire connections at the terminal block on the motor can be easily reached and disconnected.
7. Disconnect the motor wires at the terminal block on the motor and then disconnect the two (2) red wires connected to the auxiliary limit control mounted on the opposite side of the blower.

8. Swing control box out of the way of the blower and remove blower from unit.

CAUTION

Be sure the blower is adequately supported when sliding out of the mounting rails, especially in the horizontal position, in order to prevent dropping the blower and injuring yourself or damaging the blower!

9. Reverse the above steps to reinstall the blower. (Refer to wiring diagram Figure 10 of this instruction or the diagram located on the inside of the door to properly rewire the unit.)

MINIMUM CLEARANCE TO COMBUSTIBLES

(Adequate service clearance should be provided over and above these dimensions, as required.)

CLEARANCE FROM :	UPFLOW	HORIZONTAL
Top of furnace casing or plenum	2"	2"
Top of horizontal warm-air duct within 6 ft of furnace	2"	3"
Flue pipe, measured horizontally or below pipe	9"	9"
Flue pipe, measured vertically above pipe	9"	9"
Any side of supply plenum and warm-air duct within 6 ft of furnace	1"	1"
Front of furnace	24"	24"
Sides of furnace	2"	2"
Rear of furnace	2"	2"
Bottom of furnace	0"	0"

* Floor may be combustible

Figure 5

WARNING

When operating the furnace in the heating mode, the static pressure and the temperature rise (supply air temperature minus return air temperature) must be within those limits specified on the rating label. Failure to follow this warning could lead to severe furnace damage.

AIR-FLOW DATA

UNIT OUTPUT (KBTUH)	BLOWER SPEED	EXTERNAL STATIC									
		0.1	0.2	0.3	0.4	0.5	0.6	0.7	0.8	0.9	1.0
150 and 200 (12 X 12 WHEEL) (3/4 HP MOTOR)	LOW	1640	1590	1540	1515	1460	1410	1350	1275	1190	1075
	MED	2195	2125	2060	1990	1915	1860	1785	1700	1620	1525
	HIGH	2485	2395	2305	2250	2145	2075	1975	1885	1780	1675

NOTES:

- 1). AIR FLOW VALUES IN CUBIC FEET PER MINUTE (CFM), ROUNDED TO NEAREST FIVE (5) CFM
- 2). DATA TAKEN WITHOUT FILTERS IN PLACE

Figure 6

GENERAL LAYOUT MULTI-POISE OIL FURNACE

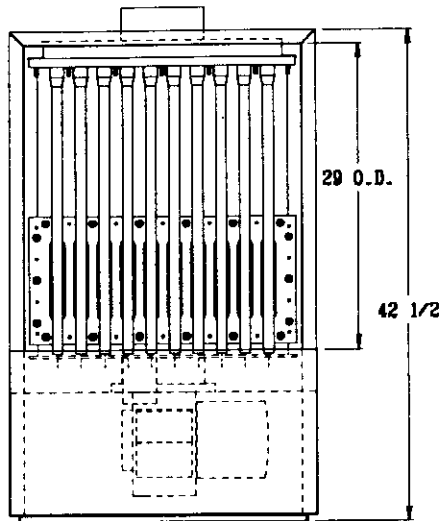

NOTE:
1) VIEWS SHOWN WITH DOORS REMOVED.

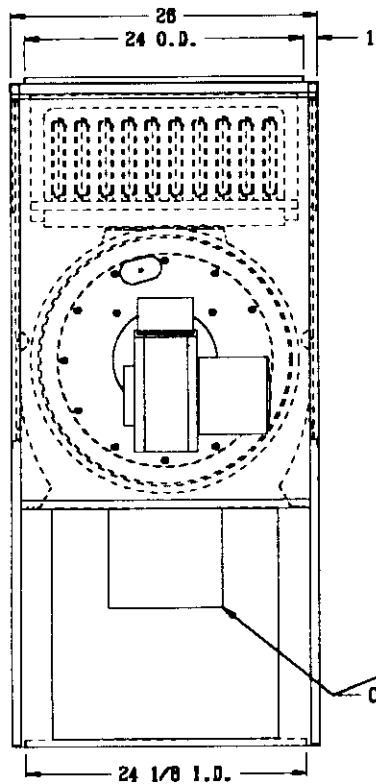

UP FLOW

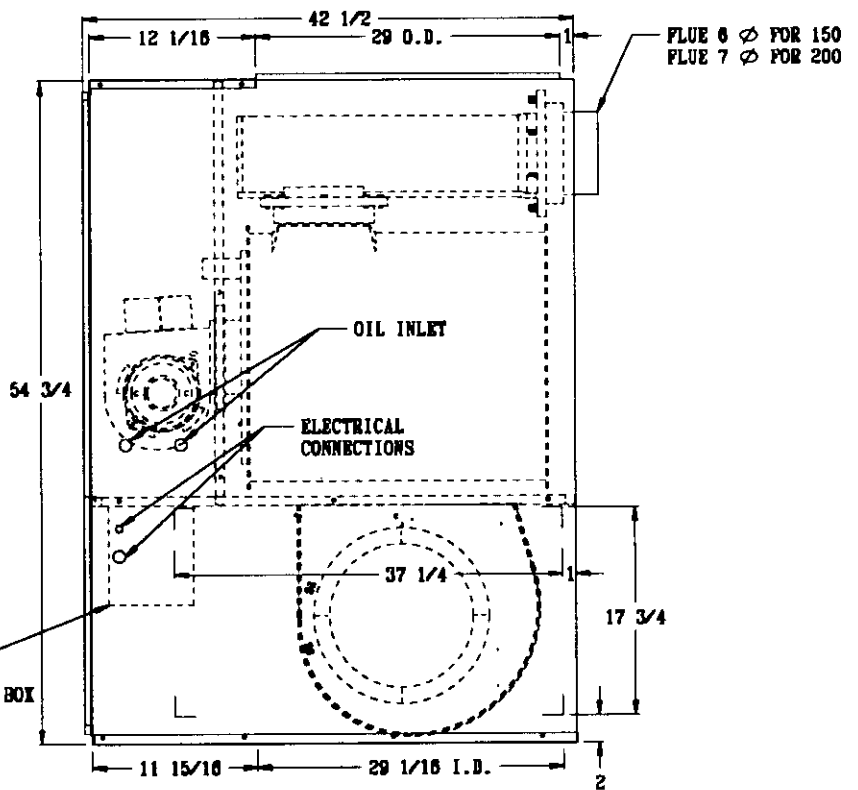

GENERAL LAYOUT UHZ 150/200 MULTI-POISE OIL FURNACE

OH1

UHZLIT1

Figure 7

BAROMETRIC DAMPER LOCATIONS

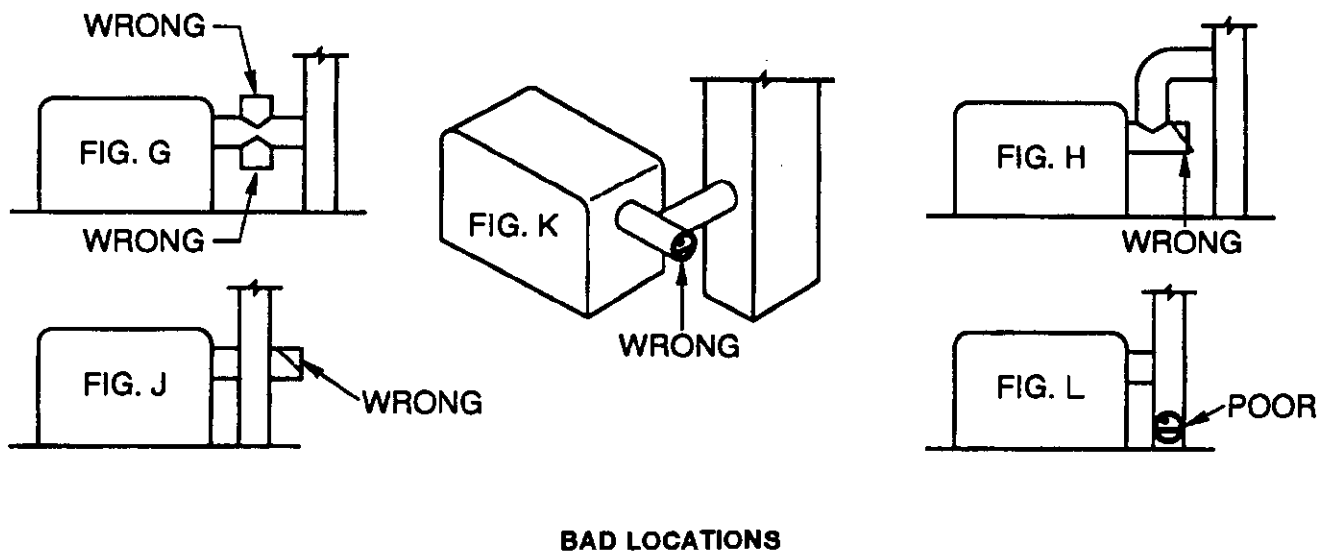
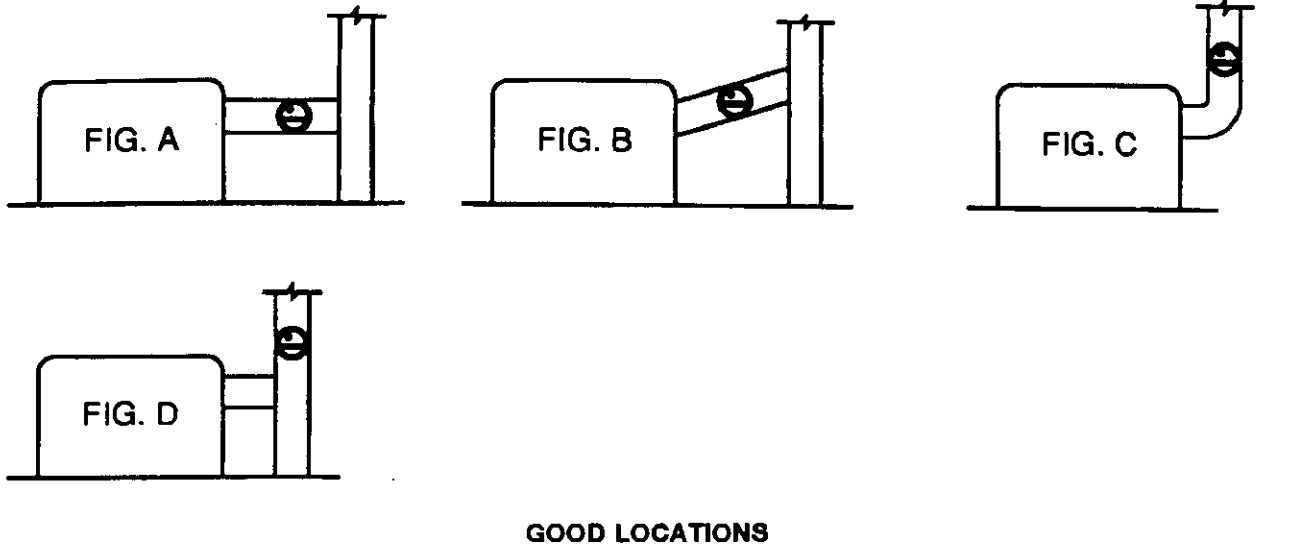

Figure 8

Filters

A filter and filter rack is supplied with the furnace. It is **NECESSARY THAT ALL FURNACES BE EQUIPPED WITH A FILTER.**

When filter rack is used on side of furnace:

1. Filter rack may be mounted on either side of furnace.
2. The filter rack is made up of four (4) pieces - a top and bottom (which are the same), and the rear and access panels (which are the same). (Use the shorter two rear/access panels—discard the long pair.)
3. Using corner indentations as a guide, cut out the selected side duct return opening (See Figure 7).
4. Clip the filter rack pieces together, as shown in Figure 9.
5. Place the flange of the filter rack bottom piece against the side panel of the furnace, resting on top of the flange of the base panel. Align the flange of the filter rack rear panel flush with the back of the furnace. (The frame should be centered over the knockout opening.)
6. Hold the filter rack against the unit (make sure it is square) and drill the mounting holes in the side of the unit located according to the clearance holes in the filter rack top, bottom, and rear panels. **DO NOT SCREW THE ACCESS PANEL IN PLACE!**
7. To fasten return air duct to filter rack, first cut a notch in the return air duct (for filter access panel) to dimension shown in detail. Then slide duct over filter rack.
8. Remove access panel, slide filter in place, then replace access panel.

Remove metal rod from filter. Trim $\frac{1}{4}$ " from width of filter ($24\frac{1}{2}$ " to $20\frac{1}{4}$ "). Reinsert rod into filter at an angle, so that it does not extend past sides of filter. Remove access panel, slide filter in place, then replace access panel.

When filter rack is used on return air End opening of furnace (either upflow, or horizontal):

1. Clip the filter rack pieces together, as shown above. (Use the longer two rear/access panels—discard the shorter pair.)
2. Position the rack centered over the opening in the supply end of the furnace, with access panel toward front of unit.
3. Hold the filter rack against the end of the unit

(make sure it is square) and drill the mounting holes in the end of the unit according to the clearance holes in the filter rack top, bottom, and rear panels. **DO NOT SCREW THE ACCESS PANEL IN PLACE!**

4. To fasten return air duct to filter rack, first cut a notch in the return air duct (for filter access panel) to dimension shown in detail. Then slide duct over filter rack.
5. Remove access panel, slide filter in place, then replace access panel.

Minimum filter size and suggested filter material: (If different type filter is used, it must be an equivalent high airflow capacity.) $36\frac{1}{2}$ " X $24\frac{1}{2}$ "



WARNING

Never operate unit without a filter or with filter access door removed. Failure to adhere to this warning could lead to a hazardous condition which could lead to equipment damage and bodily harm.

Keeping Filters Clean

As a homeowner, this is your most important responsibility. A dirty filter reduces the efficiency of your system, causes erratic performance of controls and could result in damage to the motor or heating element.

1. Inspect filters at regular intervals depending upon dirt conditions. For new homes, check filters every week for 4 consecutive weeks. In all cases, inspect your filters at least every 3 to 4 weeks when the system is in constant operation. Replace or clean filter at least at the beginning of each season (heating and cooling) and thereafter as needed.
2. If the permanent filter supplied with the filter rack becomes dirty, it can be cleaned with cold water and soap.

Be sure that the filter is thoroughly dry before installing back into the furnace.

FILTER RACK ARRANGEMENT INSTALLATION

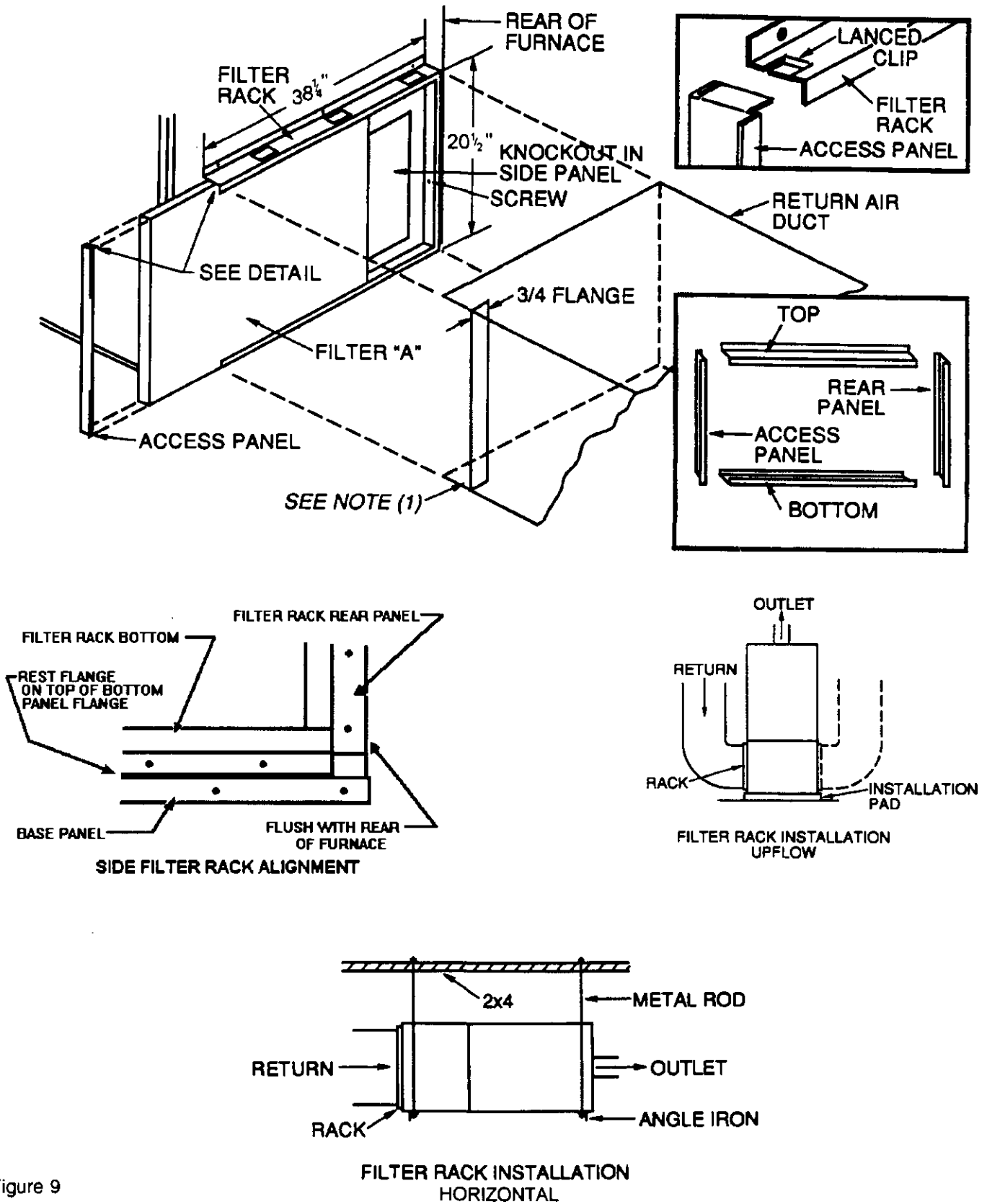
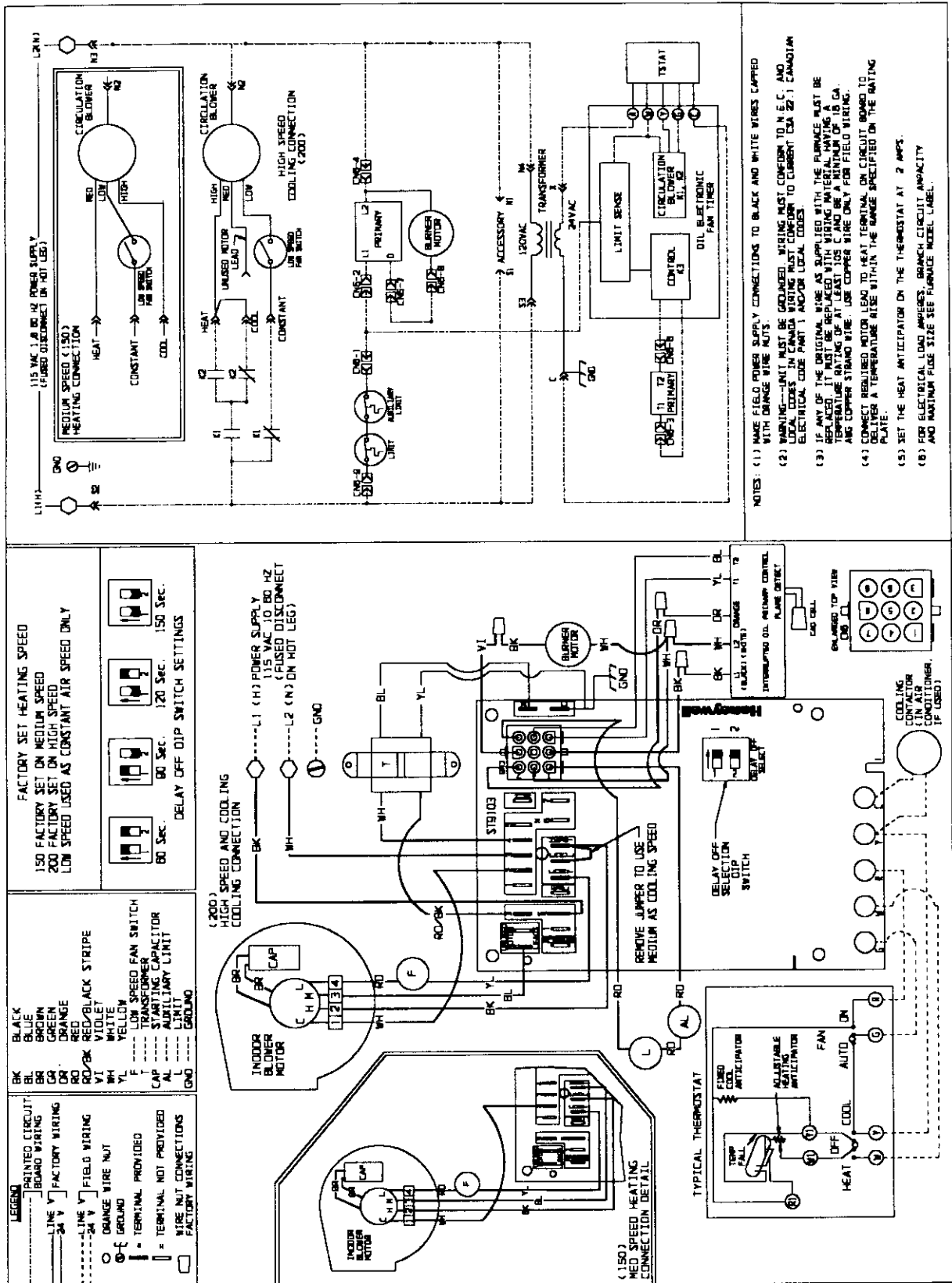

Figure 9

Figure 10



STANDARD HEAT/COOL WIRING DIAGRAM WITH STB103 ELECTRONIC FAN TIMER THREE-POSITION OIL FURNACE

