

INSTALLATION INSTRUCTIONS

WALL MOUNTED PACKAGE AIR CONDITIONERS

MODEL

WA121

PATENT PENDING

DATE: 07-27-93

**MANUAL 2100-234 REV.
SUPERSEDES REV.
FILE VOL. III, TAB 16**

SECTION 1 --GETTING OTHER INFORMATION AND PUBLICATIONS

These publications can help you install the air conditioner or heat pump. You can usually find these at your local library or purchase them directly from the publisher. Be sure to consult current edition of each standard.

National Electrical Code	-ANSI/NFPA 70
Standard For The Installation Of Air Conditioning and Ventilating Systems	-ANSI/NFPA 90A
Standard For Warm Air Heating and Air Conditioning Systems	-ANSI/NFPA 90B
Load Calculation For Residential Winter and Summer Air Conditioning	-ACCA Manual J
Duct Design For Residential Winter and Summer Air Conditioning and Equipment Selection	-ACCA Manual D

FOR MORE INFORMATION, CONTACT THESE PUBLISHERS

ACCA:	AIR CONDITIONING CONTRACTORS OF AMERICA 1513 16th Street NW Washington, DC 20036 Telephone: (202) 483-9370	Fax: (202) 234-4721
ANSI:	AMERICAN NATIONAL STANDARDS INSTITUTE 11 West Street, 13th Floor New York, NY 10036 Telephone: (212) 642-4900	Fax: (212) 302-1286
ASHRAE:	AMERICAN SOCIETY OF HEATING REFRIGERATING AND AIR CONDITIONING ENGINEERS, INCORPORATED 1791 Tullie Circle, N.E. Atlanta, GA 30329-2305 Telephone: (404) 636-8400	Fax: (404) 321-5478
NFPA:	NATIONAL FIRE PROTECTION ASSOCIATION Batterymarch Park P. O. Box 9101 Quincy, MA 02269-9901 Telephone: (800) 344-3555	Fax: (617) 984-7057

TABLE OF CONTENTS

PART 1 -- WALL MOUNT--GENERAL INSTALLATION INFORMATION

Air Conditioner Wall Mount Model Nomenclature	1
Shipping Damage	1
General	4
Duct Work	4
Filters	4
Fresh Air Intake	4
Condensate Drain	4

PART 2 -- INSTALLATION

Wall Mounting Information	5
Mounting The Unit	5

WIRING

Wiring--Main Power	7
Wiring: Low Voltage Wiring	7

PART 3 -- START-UP

Important Installer Note	9
Service Hints	9
Sequence of Operation	9
Pressure Service Ports	9

PART 4 -- TROUBLESHOOTING

Fan Blade Setting Dimensions	9
Refrigerant Charge	10
Pressure Tables	11
Optional Accessories.	11

FIGURES AND TABLES

Figure 1	Unit Dimensions	2
Figure 2	Mounting Locations	6
Figure 3	Unit 24V Terminal Board	8
Figure 4	Fan Blade Setting	9

Table 1	Electric Heat Table	1
Table 2	Electrical Specifications	3
Table 3	Thermostat Wire Sizes	7
Table 3A	Wall Thermostat and Subbase Combinations.	7
Table 4	Fan Blade Setting	9
Table 5	Refrigerant Charge	10
Table 6	Indoor Blower Performance	10
Table 7	Recommended Operating Ranges	10
Table 8	Maximum ESP of Operation	10
Table 9	Cooling--Pressure (PSI)	11
Table 10	Optional Accessories	11

PART 1 -- WALL MOUNT GENERAL INFORMATION

AIR CONDITIONER WALL MOUNT MODEL NOMENCLATURE

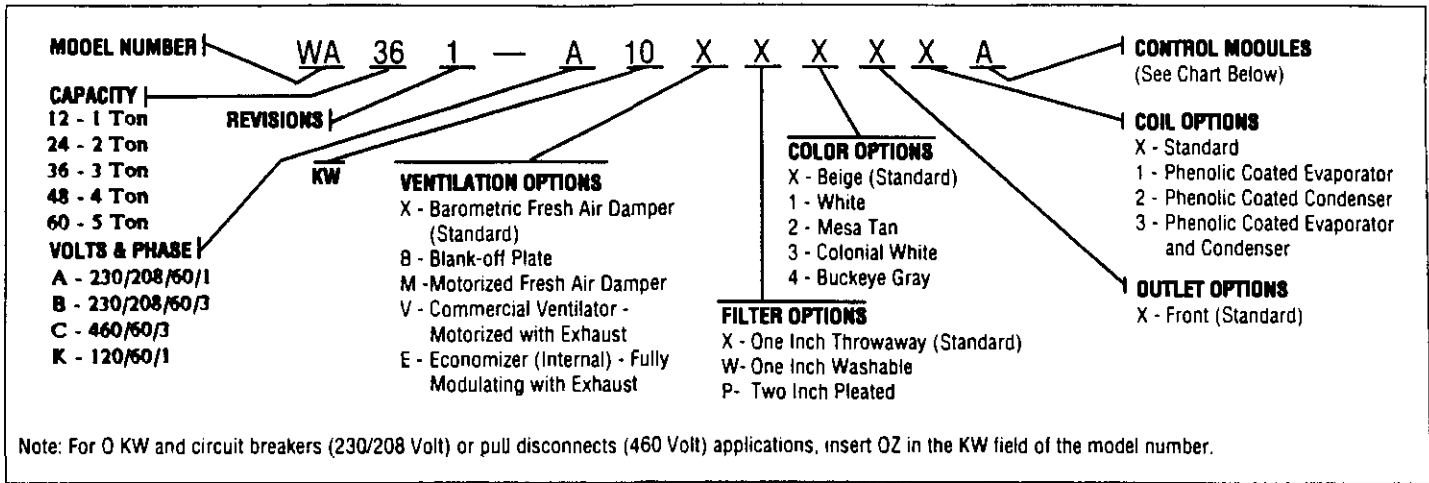

TABLE 1 ELECTRIC HEAT TABLE

Models	WA121-A				WA121-K		
	240-1V		208-1V		120V		
	KW	A	BTU	A	BTU	A	BTU
03	15.0	12285	13.0	9230			
05	20.8	17065	18.1	12800			
02						18.3	7510

SHIPPING DAMAGE

Upon receipt of equipment, the carton should be checked for external signs of shipping damage. If damage is found, the receiving party must contact the last carrier immediately, preferably in writing, requesting inspection by the carrier's agent.

FIGURE 1
UNIT DIMENSIONS

SIZE SPECS FOR H1S-500

UNIT	WIDTH (W)	DEPTH (D)	HEIGHT (H)	SUPPLY			RETURN			E	F	G (**)	I	J (**)	K	L	M
				A	B	C	B	C	B								
H1S21	30-1/8	14-5/8	46	5	17	10	17	32	10-1/4	2 OR 5	19-7/8	23-3/4 OR 26-3/4	20-1/4	2-1/2	31-1/16		

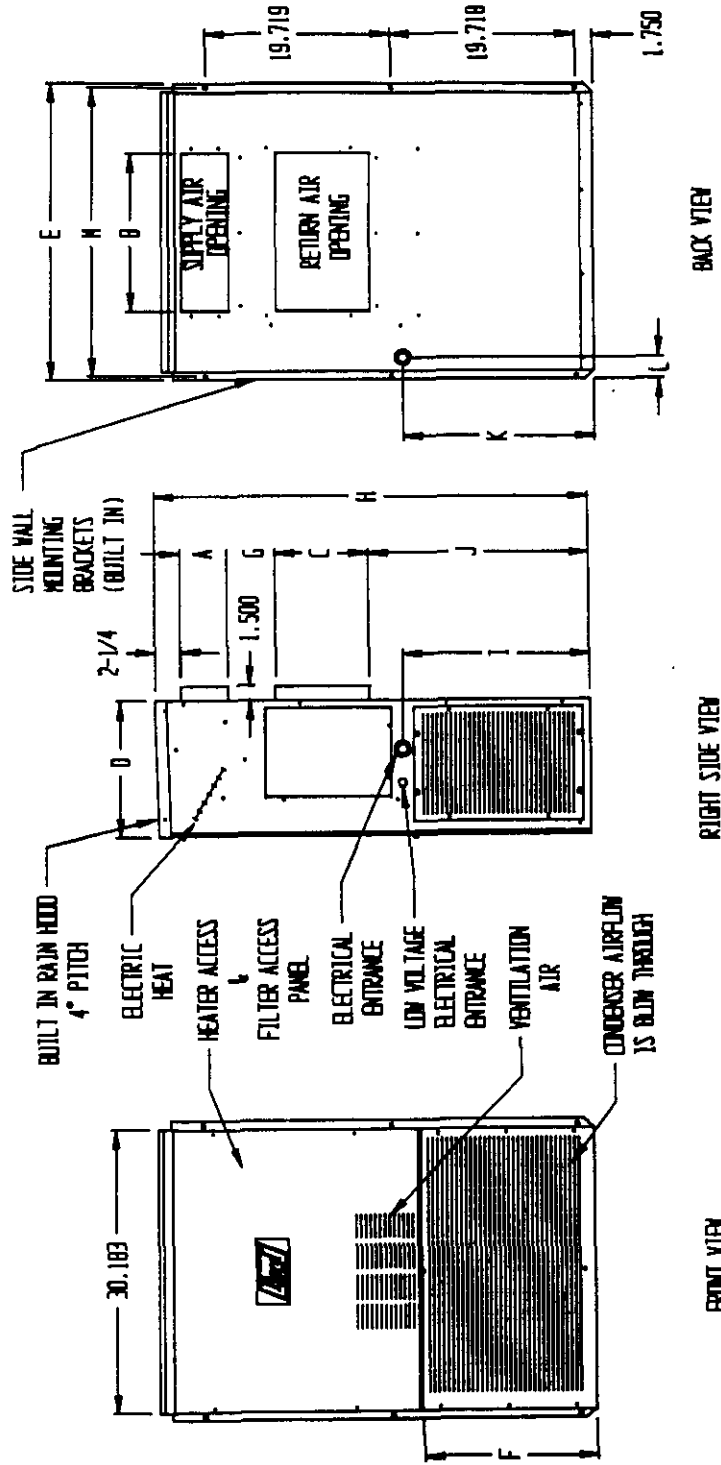

(**) POSITION OF RETURN AIR FLANGES ARE INTERCHANGEABLE BETWEEN TWO POSITIONS.

TABLE 2

SINGLE CIRCUIT						
Model	Rated Volts and Phase	No. Field Power Ckts.	(3) Minimum Circuit Ampacity	(1) Maximum External Fuse Or Circuit Breaker	(2) Field Power Wire Size	(2) Ground Wire Size
WA121-A00, A0Z	230/208-1	1	8	15	14	14
A03		1	20	20	12	12
A05		1	27	30	10	10
WA121-K00	115-1	1	17	25	10	10
K02		1	25	30	10	10

(1) Maximum size of the time delay fuse or HACR type circuit breaker for protection of field wiring conductors.

(2) Based on 75°C copper wire. All wiring must conform to NEC and all local codes.

(3) These "Minimum Circuit Ampacity" values are to be used for sizing the field power conductors. Refer to the National Electrical Code (latest revision), article 310 for power conductor sizing. Caution: When more than one field power conductor circuit is run thru one conduit, the conductors must be derated. Pay special attention to note 8 of table 310 regarding Ampacity Adjustment Factors when more than 3 conductors are in a raceway.

GENERAL

The equipment covered in this manual is to be installed by trained, experienced service and installation technicians.

The refrigerant system is completely assembled and charged. All internal wiring is complete.

The unit is designed for use with or without duct work. Flanges are provided for attaching the supply and return ducts.

These instructions explain the recommended method to install the air cooled self-contained unit and the electrical wiring connections to the unit.

These instructions and any instructions packaged with any separate equipment required to make up the entire air conditioning system should be carefully read before beginning the installation. Note particularly "Starting Procedure" and any tags and/or labels attached to the equipment.

While these instructions are intended as a general recommended guide, they do not supersede any national and/or local codes in any way. Authorities having jurisdiction should be consulted before the installation is made. See Page 1 for information on codes and standards.

Size of unit for a proposed installation should be based on heat loss calculation made according to methods of Air Conditioning Contractors of America (ACCA). The air duct should be installed in accordance with the Standards of the National Fire Protection Association for the Installation of Air Conditioning and Ventilating systems of Other Than Residence Type, NFPA No. 90A, and Residence Type Warm Air Heating and Air Conditioning Systems, NFPA No. 90B. Where local regulations are at a variance with instructions, installer should adhere to local codes.

DUCT WORK

All duct work, supply and return, must be properly sized for the design air flow requirement of the equipment. Air Conditioning Contractors of America (ACCA) is an excellent guide to proper sizing. All duct work or portions thereof not in the conditioned space should be properly insulated in order to both conserve energy and prevent condensation or moisture damage.

Refer to Table 8 for maximum static pressure available for duct design.

Design the duct work according to methods given by the Air Conditioning Contractors of America (ACCA). When duct runs through unheated spaces, it should be insulated with a minimum of one inch of insulation. Use insulation with a vapor barrier on the outside of the insulation. Flexible joints should be used to connect the duct work to the equipment in order to keep the noise transmission to a minimum.

Ducts through the walls must be insulated and all joints taped or sealed to prevent air or moisture entering the wall cavity.

Some installations may not require any return air duct. It is recommended that on this type of installation that a filter grille be located in the wall. Filters must be of sufficient size to allow a maximum velocity of 400 FPM.

NOTE: If no return air duct is used, applicable installation codes may limit this cabinet to installation only in a single story structure.

FILTERS

A 1-inch throwaway filter is supplied with each unit. The filter slides into position making it easy to service. This filter can be serviced from the outside by removing the service door. A 2-inch pleated filter is also available as an optional accessory. The internal filter brackets are adjustable to accommodate the 2-inch filter by loosening 2 screws in each bracket assembly and sliding the brackets apart to the required width and retightening the 4 screws.

FRESH AIR INTAKE

All units are built with a fresh air inlet slots punched in the service panel.

The fresh air damper assembly is standard equipment with the unit because of the variety of state or local codes requiring fresh air capability. It is shipped already attached to each unit.

All capacity, efficiency and cost of operation information as required for Department of Energy "Energyguide" Fact Sheets is based upon the fresh air blank-off plate in place and is recommended for maximum energy efficiency.

The blank-off plate is available upon request from the factory and is installed in place of the fresh air damper shipped with each unit.

CONDENSATE DRAIN

This unit employs an automatic condensate disposal system consisting of a base drain pan, drain valve and fan blade with slinger ring. A plastic drain hose extends from the evaporator drain pan at the top of the unit to the base drain pan at the bottom. At temperatures above 40°, the drain valve located between the condenser coil and fan shroud is closed allowing water to build up in the base to a height of 5/8" to 3/4". The fan blade with slinger then rotates in this water and throws the water onto the condenser coil. This disposes of the water by evaporating it on the hot condenser.

At temperatures below 40°, the drain valve opens draining the base pan and preventing freeze ups that could damage the coil or fan blade.

PART 2 -- INSTALLATION INSTRUCTIONS

WALL MOUNTING INFORMATION

1. These units are secured by wall mounting brackets which secure the unit to the outside wall surface at both sides. A bottom mounting bracket is provided for ease of installation, but is not required.
2. On wood-frame walls, the wall construction must be strong and rigid enough to carry the weight of the unit without transmitting any unit vibration.
3. Concrete block walls must be thoroughly inspected to insure that they are capable of carrying the weight of the installing unit.

MOUNTING THE UNIT

1. Two holes, for the supply and return air openings, must be cut through the wall as shown in Figure 2.
2. Locate and mark lag bolt locations and bottom mounting bracket location, if desired. See Figure 2.
3. Hook top rain flashing under back bend of top. Top rain flashing is shipped attached to the back of the unit on the right side.
4. Position unit in opening and secure with 5/16 lag bolts; use 7/8 inch diameter flat washers on the lag bolts.
5. Secure rain flashing to wall and caulk across entire length of top. See Figure 2.
6. For additional mounting rigidity, the return air and supply air frames or collars can be drilled and screwed or welded to the structural wall itself (depending upon wall construction). Be sure to observe required clearance if combustible wall.
7. On side by side installations, maintain a minimum of 20 inches clearance on right side to allow access to control panel and heat strips and allow proper airflow to Outdoor coil.

FIGURE 2
MOUNTING INSTRUCTIONS

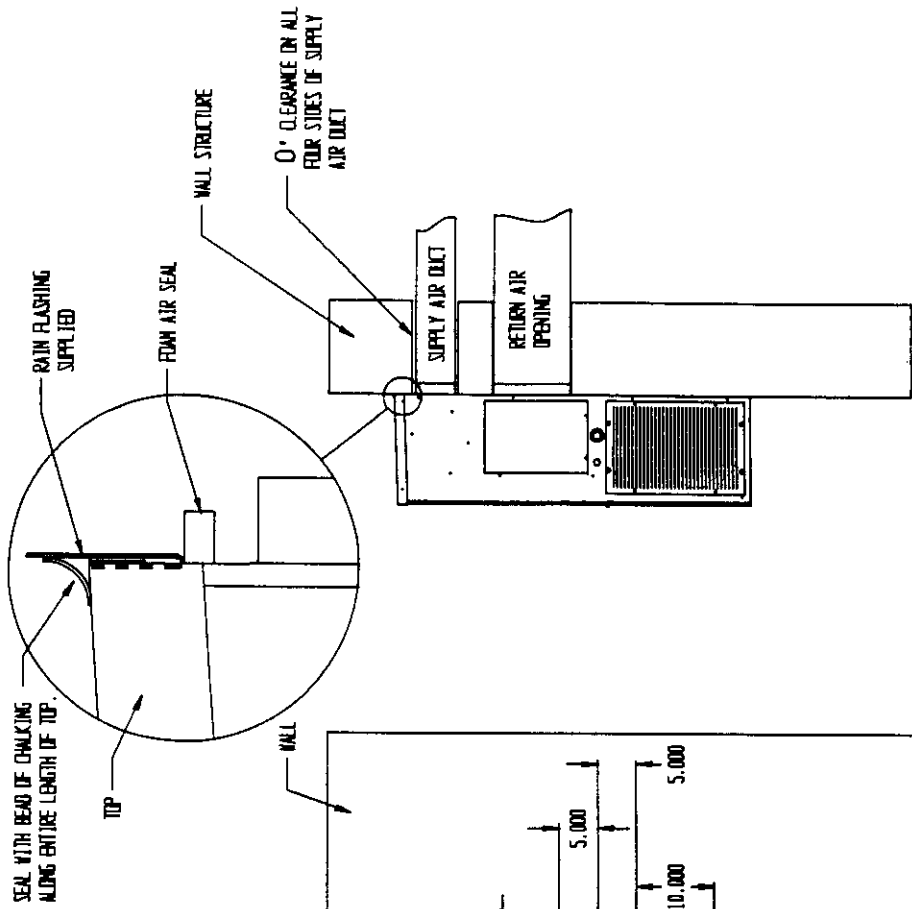

NOTE:
IT IS RECOMMENDED THAT A BEAD OF SILICONE CAULKING BE PLACED BEHIND THE SIDE MOUNTING FLANGES AND UNDER TOP FLASHING AT TIME OF INSTALLATION.

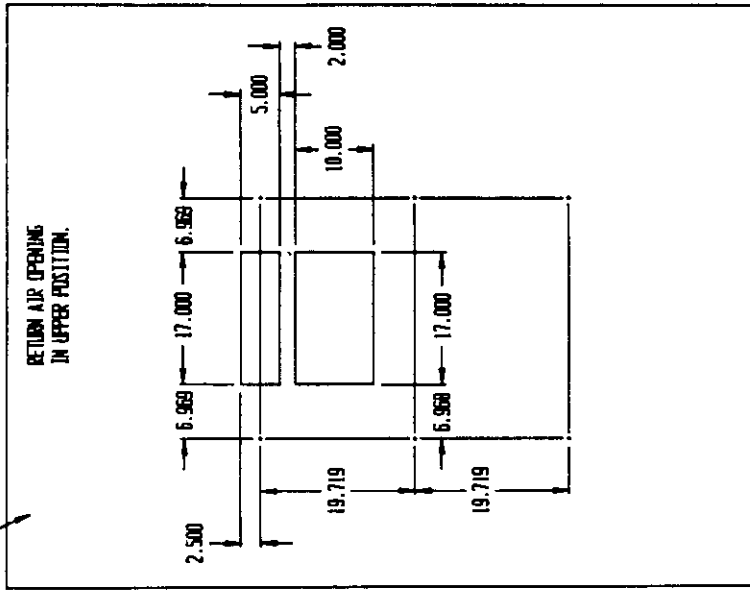
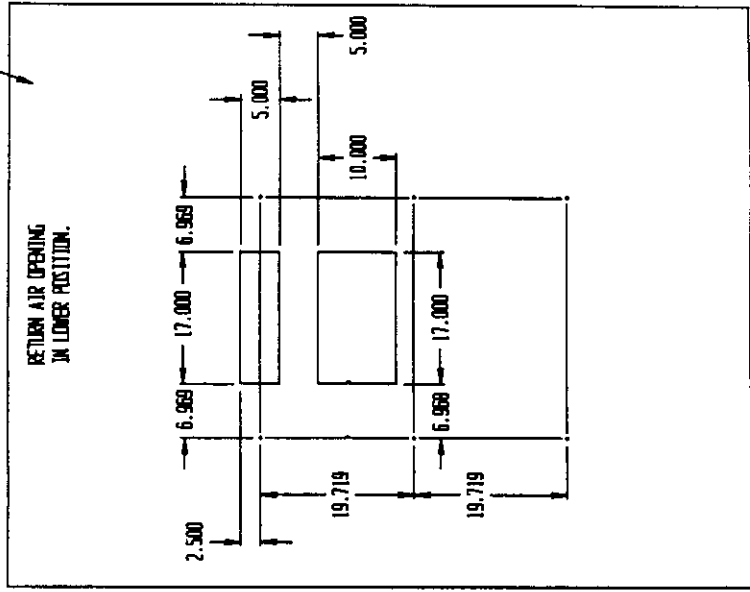

WIRING--MAIN POWER

Refer to the unit rating plate for wire sizing information and maximum fuse or "HACR Type" circuit breaker size. Each outdoor unit is marked with a "Minimum Circuit Ampacity". This means that the field wiring used must be sized to carry that amount of current. Depending on the installed KW of electric heat, there may be two field power circuits required. If this is the case, the unit serial plate will so indicate. All models are suitable only for connection with copper wire. Each unit and/or wiring diagram will be marked "Use Copper Conductors Only". These instructions MUST BE adhered to. Refer to the National Electrical Code (NEC) for complete current carrying capacity data on the various insulation grades of wiring material. All wiring must conform to NEC and all local codes.

The electrical data lists fuse and wire sizes (75°C copper) for all models, including the most commonly used heater sizes. Also shown are the number of field power circuits required for the various models with heaters.

The unit rating plate lists a "Maximum Time Delay Relay Fuse" or "HACR Type" circuit breaker that is to be used with the equipment. The correct size must be used for proper circuit protection and also to assure that there will be no nuisance tripping due to the momentary high starting current of the compressor motor.

WIRING: LOW VOLTAGE WIRING

230/208V, 1 phase equipment use dual primary voltage transformers. All equipment leaves the factory wired on 240V tap. For 208V operation, reconnect from 240V to 208V tap. The acceptable operating voltage range for the 240 and 208V taps are:

	TAP	RANGE
	240	253 - 216
	208	220 - 187
115V, 1 phase equipment:	115	126 - 103

NOTE: The voltage should be measured at the field power connection point in the unit and while the unit is operating at full load (maximum amperage operating condition).

Five (5) wires should be run from thermostat subbase to the 24V terminal board in the unit. A five conductor, 18 gauge copper, color-coded thermostat cable is recommended. The connection points are shown in Figure 3.

TABLE 3 THERMOSTAT WIRE SIZE

Transformer VA	FLA	Wire Gauge	Maximum Distance In Feet
40	2.3	20 Gauge	45
		18 "	60
		16 "	100
		14 "	160
		12 "	250

TABLE 3A WALL THERMOSTAT AND SUBBASE COMBINATIONS

Thermostat	Subbase	Predominate Features
8403-019	8404-012	1 stage cool, 2 stage heat
T874C1760	Q674A1001	System: heat-auto-cool Fan: on-auto
8403-002	8404-003	1 stage heat, 1 stage cool
T87F3111	Q539A1220	System: heat-off-cool Fan: on-auto
8403-009	----	1 stage heat, 1 stage cool
1F56-318		

FIGURE 3
LOW VOLTAGE WIRING

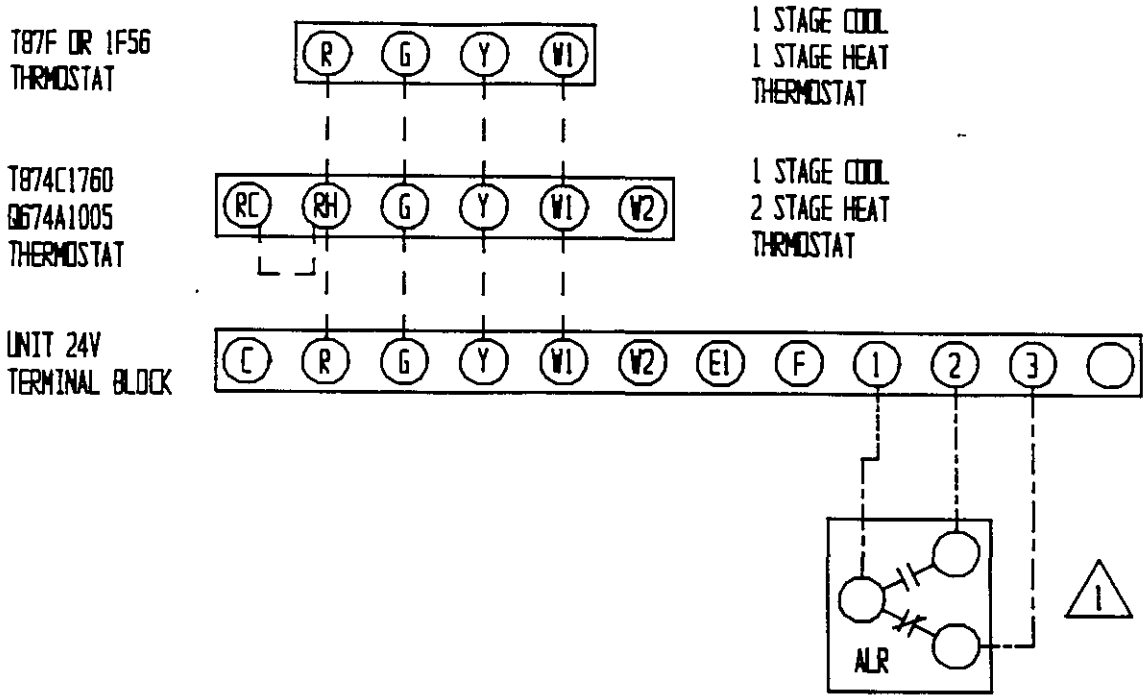

OPTIONAL ALARM RELAY PROVIDED ON UNITS WITH CONTROL MODULE "M" OR "J"
INSTALLED. CONTACT RATING 24VAC @ 125VA

OPTIONAL ECONOMIZER LOW VOLTAGE WIRING

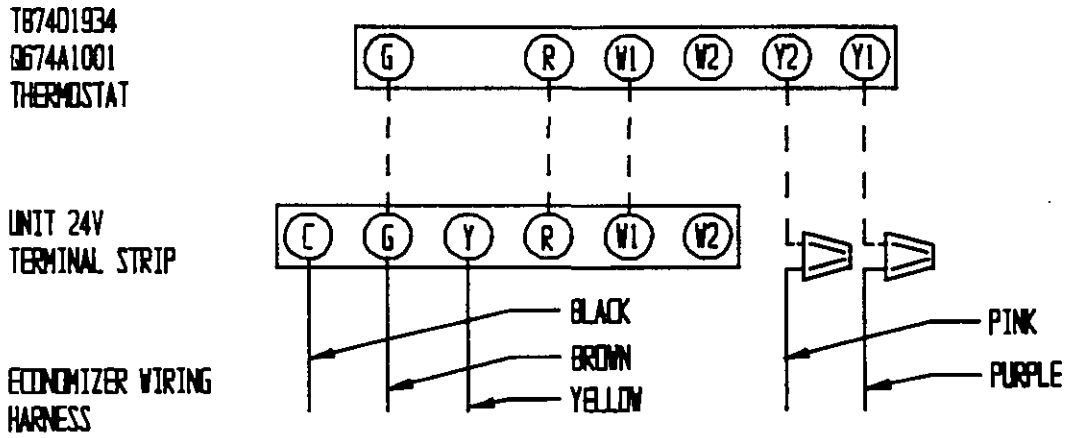

PART 3 -- START-UP

IMPORTANT INSTALLER NOTE

For improved start-up performance, wash the indoor coil with a dishwasher detergent.

SERVICE HINTS

1. Caution homeowner to maintain clean air filters at all times. Also, not to needlessly close off supply and return air registers. This reduces air flow through the system, which shortens equipment service life as well as increasing operating costs.
2. The unit is equipped with a high pressure cut out switch.
3. Check all power fuses or circuit breakers to be sure they are the correct rating.
4. Periodic cleaning of the outdoor coil to permit full and unrestricted airflow circulation is essential.

SEQUENCE OF OPERATION

COOLING--Circuit R-Y makes at thermostat pulling in compressor contactor, starting the compressor and outdoor motor. The G (indoor motor) circuit is automatically completed on any call for cooling operation or can be energized by manual fan switch on subbase for constant air circulation. On a call for heating, circuit R-W1 make at the thermostat pulling in heat contact for the strip heat and blower operation.

PRESSURE SERVICE PORTS

High and low pressure service ports are installed on all units so that the system operating pressures can be observed. Pressure curves can be found later in the manual covering all models. It is imperative to match the correct pressure curve to the unit by model number.

PART 4 -- TROUBLESHOOTING

FAN BLADE SETTING DIMENSIONS

Shown in the drawing below are the correct fan blade setting dimensions for proper air delivery across the outdoor coil.

Any service work requiring removal or adjustment in the fan and/or motor area will require that the dimensions below be checked and blade adjusted in or out on the motor shaft accordingly.

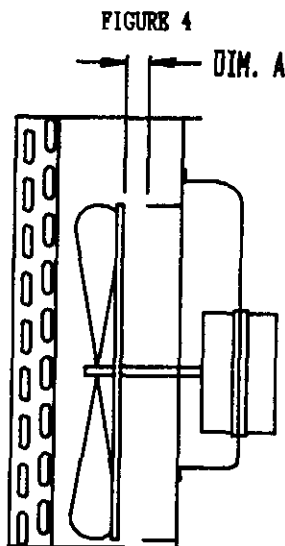

TABLE 4

Model	Dimension A
WA121	1/2"

REFRIGERANT CHARGE

The correct system R-22 charge is shown on the unit rating plate. Optimum unit performance will occur with a refrigerant charge resulting in a suction line temperature (6" from compressor) as shown in the following table:

TABLE 5

Model	Rated Airflow	95° F OD Temperature	82° F OD Temperature
WA121	400	54 - 56	65 - 67

The above suction line temperatures are based upon 80° F dry/bulb/67° F wet bulb (50 percent R.H.) temperature and rated airflow across the evaporator during cooling cycle.

TABLE 6 INDOOR BLOWER PERFORMANCE--CFM @ 230V

E.S.P. In H2O	WA121	
	230V	
	Dry	Wet
.0	530	500
.1	485	460
.2	440	425
.3	390	375
.4	325	300

TABLE 7

Model	Rated CFM*	Rated ESP*	Recommended Airflow Range
WA121	400	.25	500 - 300

*Rated CFM and ESP on high speed tap.

MAXIMUM ESP OF OPERATION

TABLE 8 ELECTRIC HEAT ONLY

Model	ESP
A00	.35
WA121 A03	.35
A05	.35
K00	.35
WA121 K02	.35

Values shown are for units equipped with STD 1" throw-away filter or 1" washable filter. Derate ESP by .15 for 2" pleated filters.

TABLE 9

COOLING

Air Temperature Entering Outdoor Coil °F

Model	Return Air Temperature	Pressure	°	°	°	°	°	°	°	°	°
			75	80	85	90	95	100	105	110	115
WA121	75 deg. DB	Low Side	72	74	76	79	81	83	86	88	91
	62 deg. WB	High Side	187	201	216	232	248	265	282	300	319
	80 deg. DB	Low Side	76	79	82	84	87	90	92	95	97
	67 deg. WB	High Side	192	207	222	238	255	272	290	309	328
	85 deg. DB	Low Side	81	85	88	91	94	97	99	102	104
	72 deg. WB	High Side	198	214	230	247	264	282	300	319	339

Low side pressure \pm 2 PSIG

High side pressure \pm 5 PSIG

Tables are based upon rated CFM (airflow) across the evaporator coil and should be found under section titled "Refrigerant Charge" elsewhere in manual. If there is any doubt as to correct operating charge being in the system, the charge should be removed, system evacuated, and recharged to serial plate instructions.

TABLE 10 OPTIONAL ACCESSORIES

Model	Description	W	W	W
		A	A	A
		1	2	2
		8	4	4
		1	1	1
		-	-	-
		A	A	B
BOP-1	Blank Off Plate	X	X	X
BEAD-1	Barometric Fresh Air Damper	X	X	X
EIPM-1	Economizer With Exhaust	X	X	X
CMA-20	LPC + TDR + LAC	X	X	X
CMA-6	Low Ambient Control	X	X	X

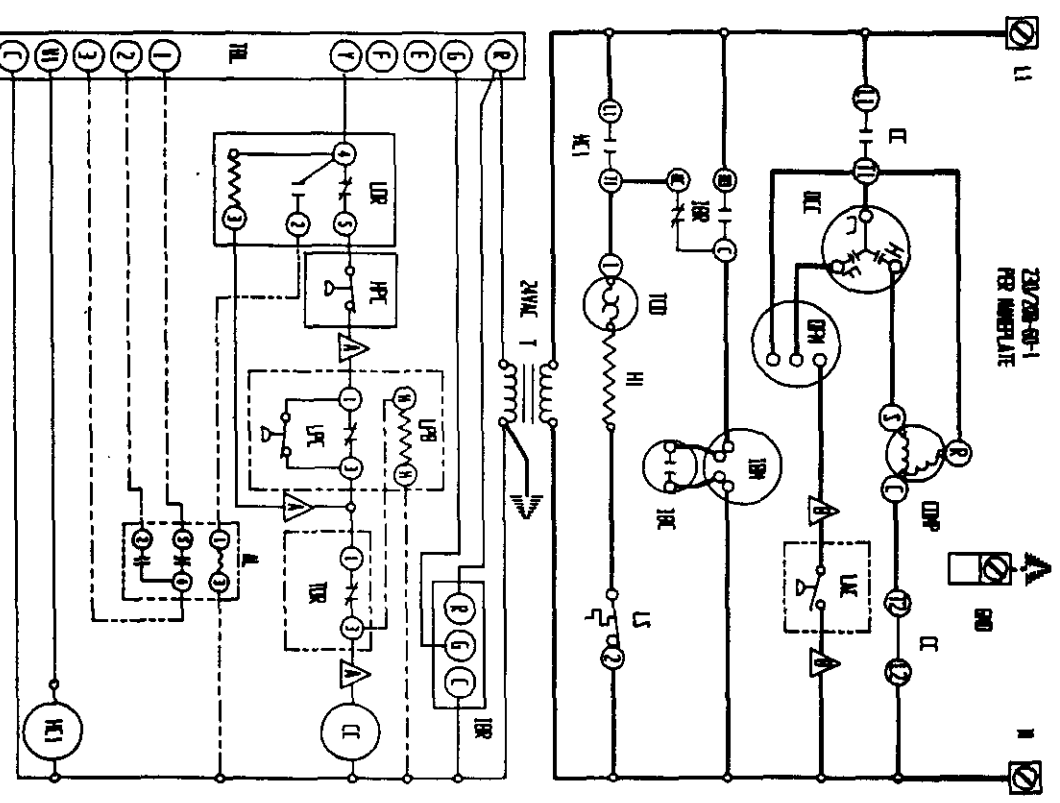
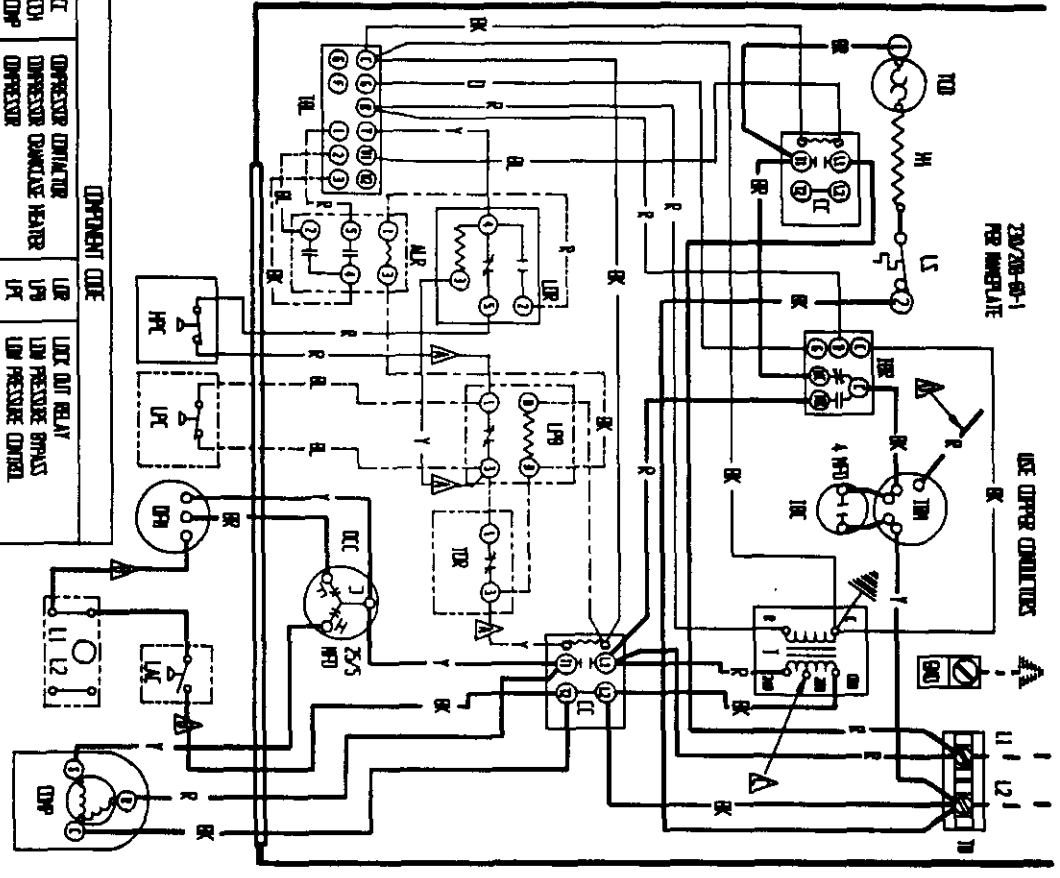

COMPONENT CODE	
CI	COMPRESSOR CONTACTOR
DH	DIFFUSER HEATER
DP	DIP
DC	DIFFUSION CAPACITOR
GD	GEAR MOTOR
HI	HEAT STRIP #1
HT	HEATER CONTACTOR #1
MI	MAINTENANCE INTERLOCK MOTOR
MP	MAINTENANCE INTERLOCK MOTOR
LR	LOW VOLTAGE RELAY
LK	LOW AMPERE CONTROL

UR	UR	UR1	UR2	UR3
UR	UR	UR1	UR2	UR3
UR	UR	UR1	UR2	UR3
UR	UR	UR1	UR2	UR3
UR	UR	UR1	UR2	UR3
UR	UR	UR1	UR2	UR3

WIRE CONNECT IF NO OPTIONS USED.		NONE RED WIRE TO 208V TAP FOR 208V OPERATION	
HIGH VOLTAGE	LOW VOLTAGE	OPTIONAL	COLOR CODE
R	R		BLACK
Y	Y		BROWN
G	G		RED
B	B		ORANGE
W	W		WHITE
Y	Y		YELLOW
GR	GR		GREEN (FR)
BL	BL		BLUE
OR	OR		ORANGE
VT	VT		VIOLET
P	P		PURPLE
BR	BR		BROWN
PK	PK		PINK
LN	LN		LAVENDER

BAIRD HYD. CO.

DES. 4005-114
DN. 11/16
CR. 4/88

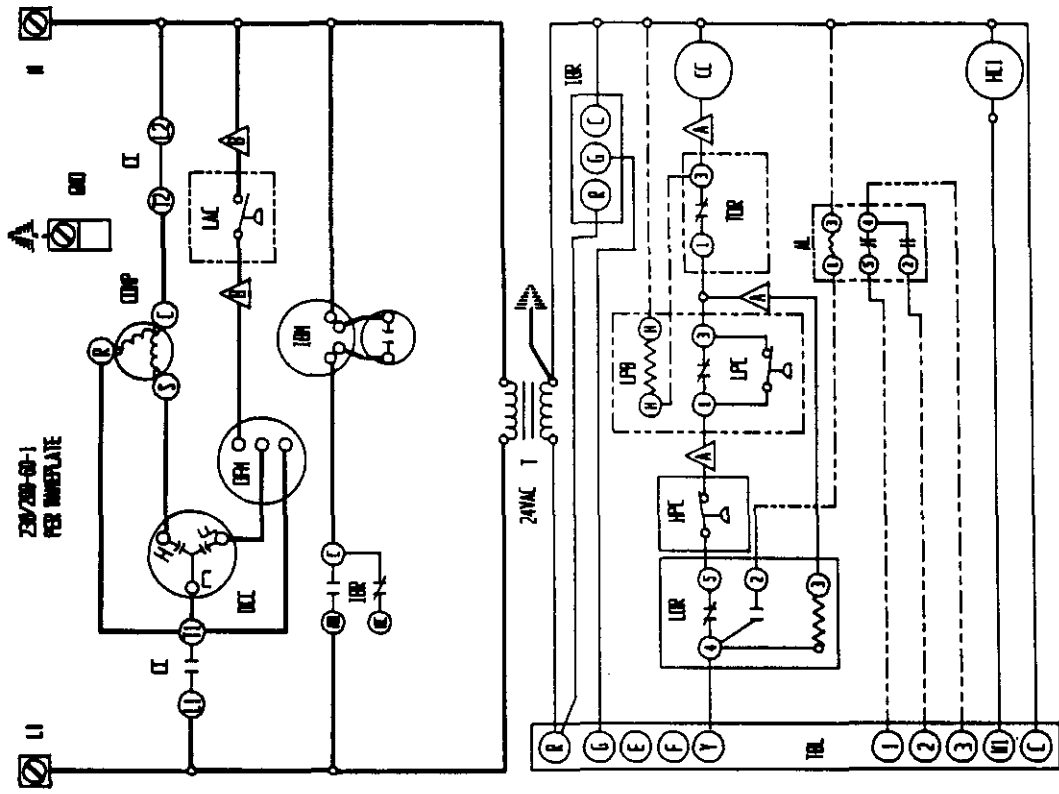
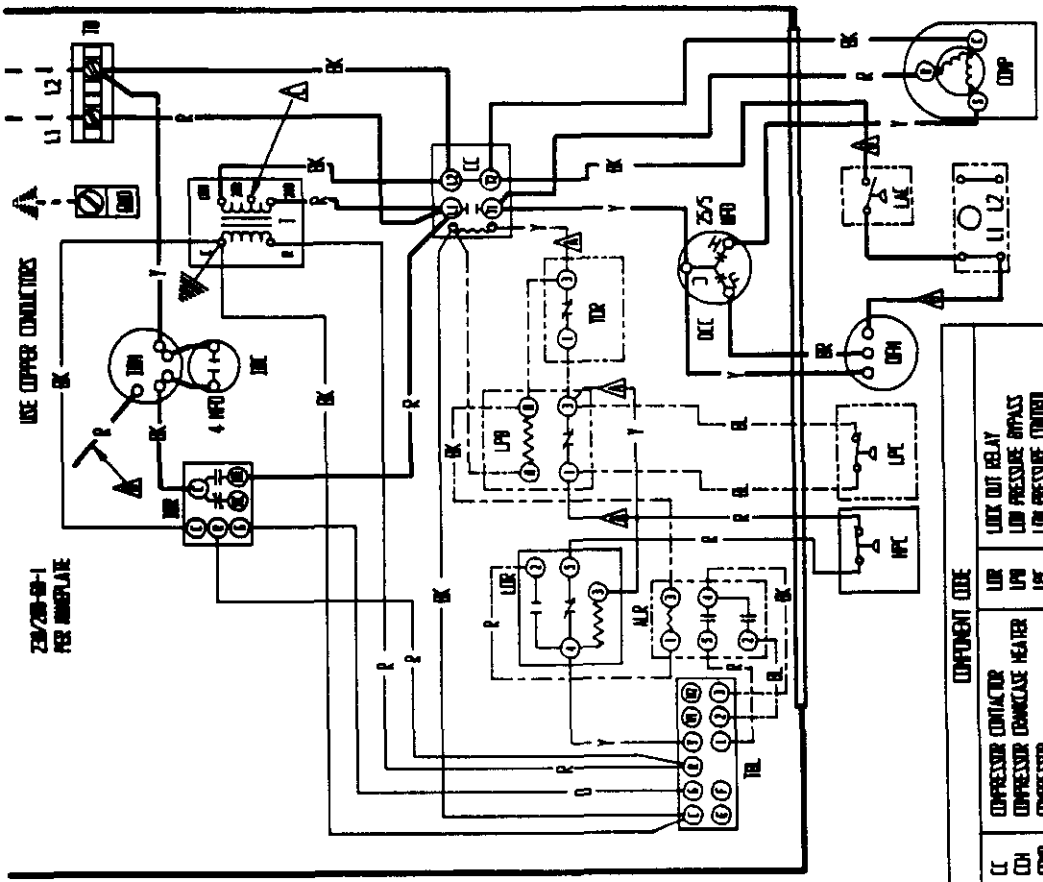

COMPONENT CODE	DESCRIPTION
UR	LOCK OUT RELAY
UR1	LOW PRESSURE BYPASS
UR2	LOW PRESSURE CONTROL
UR3	LIMIT SWITCH
UR4	OUTDOOR FAN MOTOR
UR5	TRANSFORMER
UR6	TERMINAL BLOCK
UR7	TERMINAL BLOCK 2 (OPT.)
UR8	LOW VOLTAGE TERMINAL BLOCK
UR9	TEMPERATURE CONTROL
UR10	TIME DELAY RELAY
UR11	COMPRESSOR CONTACTOR
UR12	COMPRESSOR CONTACTOR HEATER
UR13	COMPRESSOR
UR14	EQUAL CAP CAPACITOR
UR15	EQUIPMENT GROUND
UR16	HEAT STRIP #1
UR17	HEATER CONTACTOR #1
UR18	HIGH PRESSURE CONTROL
UR19	INDOOR BLOWER CAPACITOR
UR20	INDOOR BLOWER MOTOR
UR21	INDOOR BLOWER RELAY
UR22	LOW MORTISE CONTROL

△ LABELLED WIRES CONNECT IF NO OPTIONS USED. △ MORE RED WIRES TO 200V TAP FOR 200V OPERATION

BLACK	Y	VIOLET	T	TAN
BROWN	G	PURPLE	PK	PINK
RED	BL	GRAY	L	LAVENDER
ORANGE	W	SLATE		

BARD MFG. CO.			
DATE	4085-115		
DR.	DELREBE		
CHK./APP.			

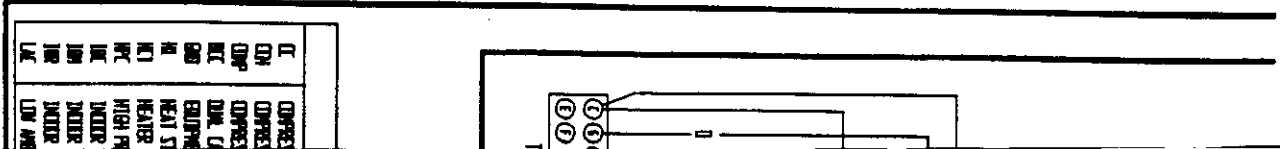

LT	COMB	COMB
LN	COMB	COMB
LM	COMB	COMB
LK	COMB	COMB
LJ	COMB	COMB
LI	COMB	COMB
LH	COMB	COMB
LG	COMB	COMB
LF	COMB	COMB
LE	COMB	COMB
LD	COMB	COMB
LC	COMB	COMB
L	COMB	COMB

①	②	③	④
---	---	---	---