



INSTALLATION INSTRUCTIONS

WALL MOUNTED PACKAGE AIR CONDITIONERS

MODELS:
WA181
WA241

BARD MANUFACTURING COMPANY
Bryan, Ohio 43506

Since 1914...Moving ahead, just as planned.

Manual:	2100-200 Rev. J
Supersedes:	Rev. I
File:	Volume III, Tab 16
Date:	January 20, 1997

SECTION 1 --GETTING OTHER INFORMATION AND PUBLICATIONS

These publications can help you install the air conditioner or heat pump. You can usually find these at your local library or purchase them directly from the publisher. Be sure to consult current edition of each standard.

National Electrical Code	-ANSI/NFPA 70
Standard For The Installation Of Air Conditioning and Ventilating Systems	-ANSI/NFPA 90A
Standard For Warm Air Heating and Air Conditioning Systems	-ANSI/NFPA 90B
Load Calculation For Residential Winter and Summer Air Conditioning	-ACCA Manual J
Duct Design For Residential Winter and Summer Air Conditioning and Equipment Selection	-ACCA Manual D

FOR MORE INFORMATION, CONTACT THESE PUBLISHERS

ACCA:	AIR CONDITIONING CONTRACTORS OF AMERICA 1712 New Hampshire Avenue N.W Washington, DC 20009 Telephone: (202) 483-9370	Fax: (202) 234-4721
ANSI:	AMERICAN NATIONAL STANDARDS INSTITUTE 11 West Street, 13th Floor New York, NY 10036 Telephone: (212) 642-4900	Fax: (212) 302-1286
ASHRAE:	AMERICAN SOCIETY OF HEATING REFRIGERATING AND AIR CONDITIONING ENGINEERS, INCORPORATED 1791 Tullie Circle, N.E. Atlanta, GA 30329-2305 Telephone: (404) 636-8400	Fax: (404) 321-5478
NFPA:	NATIONAL FIRE PROTECTION ASSOCIATION Batterymarch Park P. O. Box 9101 Quincy, MA 02269-9901 Telephone: (800) 344-3555	Fax: (617) 984-7057

Manufactured under the following U.S. patent numbers
5,301,744; 5,002,116; 4,924,934; 4,875,520; 4,825,936; 4,432,409.
Other patents pending.

COPYRIGHT JANUARY, 1997
BARD MANUFACTURING COMPANY
BRYAN, OH 43506 USA

TABLE OF CONTENTS

PART 1 -- WALL MOUNT--GENERAL INSTALLATION INFORMATION

Air Conditioner Wall Mount Model Nomenclature	1
Shipping Damage	1
General	4
Duct Work	4
Filters	5
Fresh Air Intake	5
Condensate Drain	5

PART 2 -- INSTALLATION

Wall Mounting Information	6
Mounting The Unit	6

WIRING

Wiring--Main Power	10
Wiring: Low Voltage Wiring	10

PART 3 -- START-UP

Important Installer Note	12
Crankcase Heaters	12
Service Hints	12
Sequence of Operation	12
Pressure Service Ports	13

PART 4 -- TROUBLESHOOTING

Fan Blade Setting Dimensions	13
Removal of The Fan Shroud	13
Refrigerant Charge	14
Pressure Tables	15
Optional Accessories.	16

FIGURES AND TABLES

Figure 1	Unit Dimensions	2
Figure 2	Fresh Air Damper Assembly	5
Figure 3	Mounting Instructions	7
Figure 4	Wall-Mounting Instructions	8
Figure 5	Wall-Mounting Instructions	8
Figure 6	Common Wall-Mounting Installations	9
Figure 7	Unit 24V Terminal Board	11
Figure 8	Start-Up	12
Figure 9	Fan Blade Setting	13

Table 1	Electric Heat Table	1
Table 2	Electrical Specifications	3
Table 3	Thermostat Wire Sizes	10
Table 3A	Wall Thermostat and Subbase Combinations	10
Table 4	Fan Blade Setting	13
Table 5	Refrigerant Charge	14
Table 6	Indoor Blower Performance	14
Table 7	Recommended Operating Ranges	14
Table 8	Maximum ESP of Operation	14
Table 9	Cooling--Pressure (PSI)	15
Table 10	Optional Accessories	16

PART 1 -- WALL MOUNT GENERAL INFORMATION

AIR CONDITIONER WALL MOUNT MODEL NOMENCLATURE

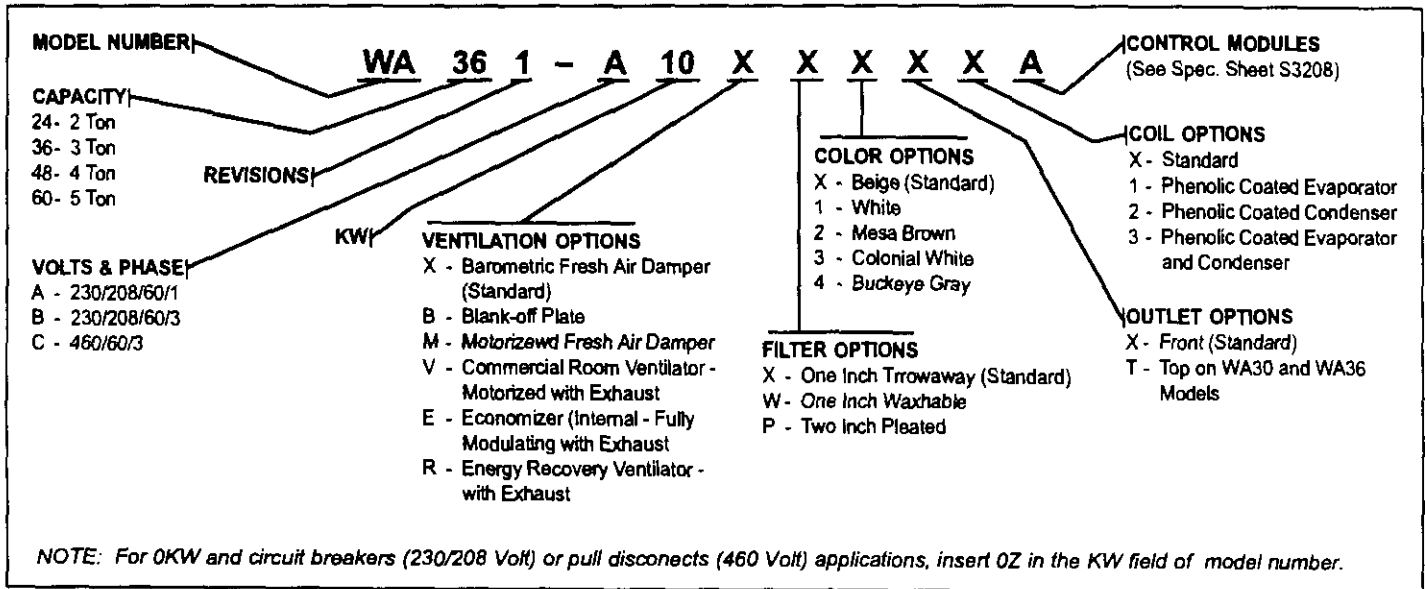

TABLE 1 ELECTRIC HEAT TABLE

Models	WA181-A				WA241-A				WA241-B			
	240-1		208-1		240-1		208-1		240-3		208-3	
	A	BTU	A	BTU	A	BTU	A	BTU	A	BTU	A	BTU
4					16.7	13650	14.4	10240				
5	20.8	17065	18.1	12800	20.8	17065	18.1	12800				
8	33.3	27300	28.8	20475	33.3	27300	28.8	20475				
10	41.6	34130	36.2	25600	41.6	34130	36.2	25600				
6									14.4	20500	12.5	15360
9									21.7	30600	18.7	23030

SHIPPING DAMAGE

Upon receipt of equipment, the carton should be checked for external signs of shipping damage. If damage is found, the receiving party must contact the last carrier immediately, preferably in writing, requesting inspection by the carrier's agent.

UNIT	WIDTH (W)	DEPTH (D)	HEIGHT (H)	SUPPLY		RETURN		E	F	G	I	J	K	L	M	N	O	P	Q
				A	B	C	D												
18 & 24	32-7/8	16-7/8	70-1/2	7-7/8	19-7/8	11-7/8	19-7/8	34-7/8	18-1/4	25-3/4	20-3/4	26-3/4	28	29-1/4	27	2-9/16	34	22-1/16	10-1/2

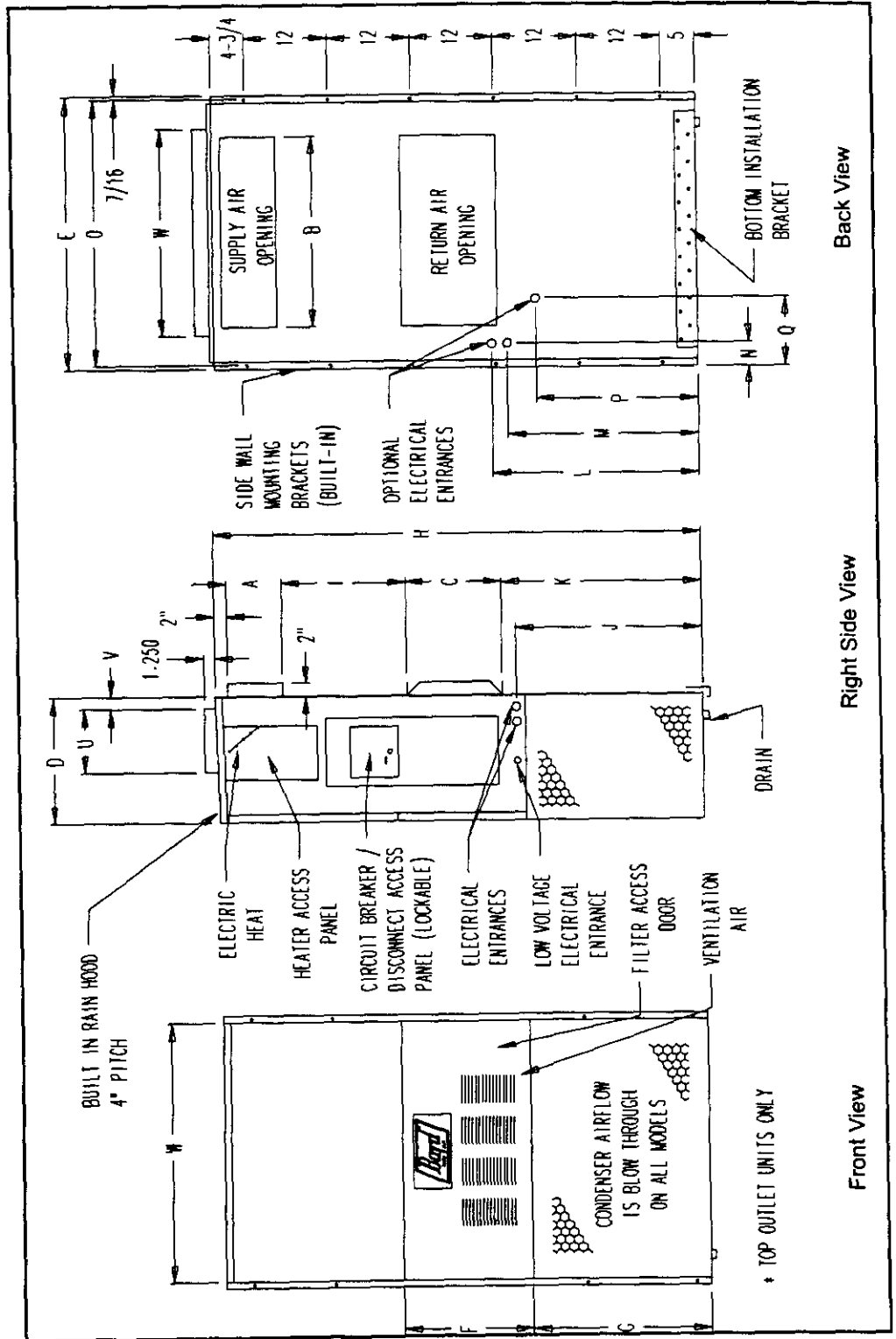

TABLE 2

SINGLE CIRCUIT						
Model	Rated Volts and Phase	No. Field Power Ckts.	(3) Minimum Circuit Ampacity	(1) Maximum External Fuse Or Circuit Breaker	(2) Field Power Wire Size	(2) Ground Wire Size
WA181-A00,A0Z	230/208-1	1	16	20	12	12
A05		1	30	30	10	10
A08		1	45	45	8	10
A10		1	56	60	6	10
WA241-A00,A0Z	230/208-1	1	17	20	12	12
A04		1	24	25	10	10
A05		1	30	30	10	10
A08		1	45	45	8	10
A10		1	56	60	6	10
WA241-B00,B0Z	230/208-3	1	13	15	14	12
B06		1	22	25	10	10

(1) Maximum size of the time delay fuse or HACR type circuit breaker for protection of field wiring conductors.

(2) Based on 75°C copper wire. All wiring must conform to NEC and all local codes.

(3) These "Minimum Circuit Ampacity" values are to be used for sizing the field power conductors. Refer to the National Electrical Code (latest revision), article 310 for power conductor sizing. Caution: When more than one field power conductor circuit is run thru one conduit, the conductors must be derated. Pay special attention to note 8 of table 310 regarding Ampacity Adjustment Factors when more than 3 conductors are in a raceway.

GENERAL

The equipment covered in this manual is to be installed by trained, experienced service and installation technicians.

The refrigerant system is completely assembled and charged. All internal wiring is complete.

The unit is designed for use with or without duct work. Flanges are provided for attaching the supply and return ducts.

These instructions explain the recommended method to install the air cooled self-contained unit and the electrical wiring connections to the unit.

These instructions and any instructions packaged with any separate equipment required to make up the entire air conditioning system should be carefully read before beginning the installation. Note particularly "Starting Procedure" and any tags and/or labels attached to the equipment.

While these instructions are intended as a general recommended guide, they do not supersede any national and/or local codes in any way. Authorities having jurisdiction should be consulted before the installation is made. See Page 1 for information on codes and standards.

Size of unit for a proposed installation should be based on heat loss calculation made according to methods of Air Conditioning Contractors of America (ACCA). The air duct should be installed in accordance with the Standards of the National Fire Protection Association for the Installation of Air Conditioning and Ventilating systems of Other Than Residence Type, NFPA No. 90A, and Residence Type Warm Air Heating and Air Conditioning Systems, NFPA No. 90B. Where local regulations are at a variance with instructions, installer should adhere to local codes.

DUCT WORK

All duct work, supply and return, must be properly sized for the design air flow requirement of the equipment. Air Conditioning Contractors of America (ACCA) is an excellent guide to proper sizing. All duct work or portions thereof not in the conditioned space should be properly insulated in order to both conserve energy and prevent condensation or moisture damage.

Refer to Table 10 for maximum static pressure available for duct design.

Design the duct work according to methods given by the Air Conditioning Contractors of America (ACCA). When duct runs through unheated spaces, it should be insulated with a minimum of one inch of insulation. Use insulation with a vapor barrier on the outside of the insulation. Flexible joints should be used to connect the duct work to the equipment in order to keep the noise transmission to a minimum.

A 1/4-inch clearance to combustible material for the first three feet of duct attached to the outlet air frame is required. See Wall Mounting Instructions and Figures 3 for further details.

Ducts through the walls must be insulated and all joints taped or sealed to prevent air or moisture entering the wall cavity.

CAUTION: Some installations may not require any return air duct. A metallic return air grille is required with installations not requiring a return air duct. The spacing between louvers on the grille shall not be larger than 5/8 inches.

Any grille that meets the 5/8 inch louver criteria, may be used. It is recommended that Bard Return Air Grille Kit RG2 thru RG5 or RFG2 thru RFG5 be installed when no return duct is used. Contact distributor or factory for ordering information. If using a return air filter grille, filters must be of sufficient size to allow a maximum velocity of 400 fpm.

NOTE: If no return air duct is used, applicable installation codes may limit this cabinet to installation only in a single story structure.

FILTERS

A 1-inch throwaway filter is supplied with each unit. The filter slides into position making it easy to service. This filter can be serviced from the outside by removing the service door. A 1-inch washable filter and 2-inch pleated filter are also available as optional accessories. The internal filter brackets are adjustable to accommodate the 2-inch filter by loosening 2 screws in each bracket assembly and sliding the brackets apart to the required width and retightening the 4 screws.

FRESH AIR INTAKE

All units are built with a fresh air inlet slots punched in the service panel.

If the unit is equipped with a fresh air damper assembly, the assembly is shipped already attached to the unit. The damper blade is locked in the closed position. To allow the damper to operate, the maximum and minimum blade position stops must be installed. See Figure 2.

All capacity, efficiency and cost of operation information as required for Department of Energy "Energyguide" Fact Sheets is based upon the fresh air blank-off plate in place and is recommended for maximum energy efficiency.

The blank-off plate is available upon request from the factory and is installed in place of the fresh air damper shipped with each unit.

CONDENSATE DRAIN

A plastic drain hose extends from the drain pan at the top of the unit down to the unit base. There are openings in the unit base for the drain hose to pass through. In the event the drain hose is connected to a drain system of some type, it must be an open or vented type system to assure proper drainage.

Figure 2

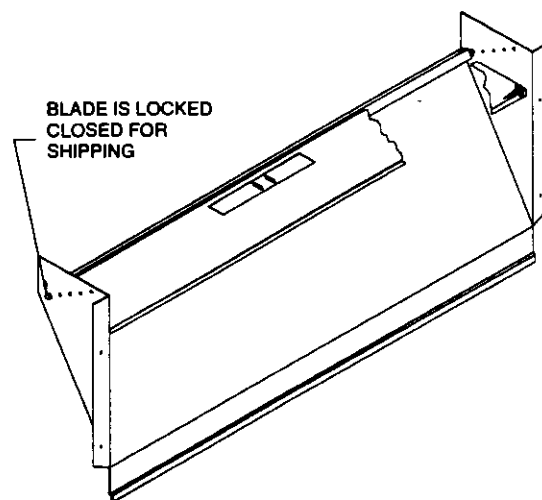

PART 2 -- INSTALLATION INSTRUCTIONS

WALL MOUNTING INFORMATION

1. These units are secured by wall mounting brackets which secure the unit to the outside wall surface at both sides. A bottom mounting bracket is provided for ease of installation, but is not required.
2. On wood-frame walls, the wall construction must be strong and rigid enough to carry the weight of the unit without transmitting any unit vibration.
3. Concrete block walls must be thoroughly inspected to insure that they are capable of carrying the weight of the installing unit.

MOUNTING THE UNIT

1. Two holes, for the supply and return air openings, must be cut through the wall as shown in Figure 3.
2. Locate and mark lag bolt locations and bottom mounting bracket location, if desired. See Figure 3.
3. Mount bottom mounting bracket, if used.
4. Hook top rain flashing under back bend of top. Top rain flashing is shipped attached to the back of the unit on the right side.
5. Position unit in opening and secure with 5/16 lag bolts; use 7/8 inch diameter flat washers on the lag bolts.
6. Secure rain flashing to wall and caulk across entire length of top. See Figure 3.
7. For additional mounting rigidity, the return air and supply air frames or collars can be drilled and screwed or welded to the structural wall itself (depending upon wall construction). Be sure to observe required clearance if combustible wall. Additional clearance may be required to meet local or national codes.
8. On side by side installations, maintain a minimum of 20 inches clearance on right side to allow access to control panel and heat strips and allow proper airflow to outdoor coil.

SEE FIGURE 3 - MOUNTING INSTRUCTIONS

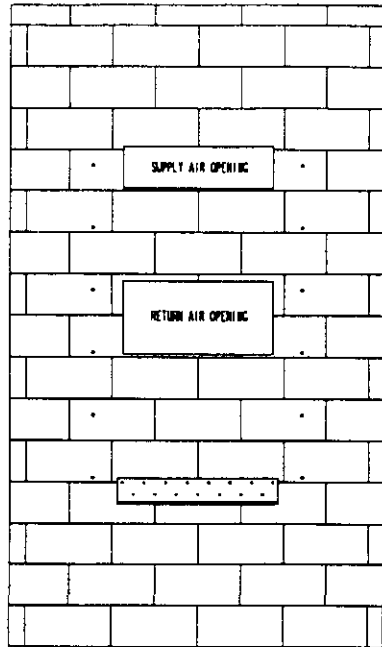

CONCRETE BLOCK WALL INSTALLATION

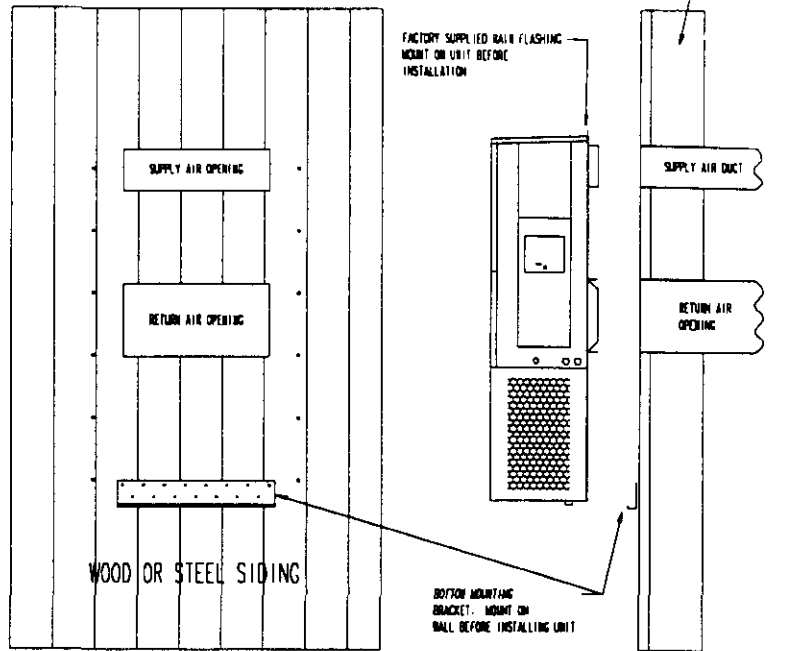

WOOD FRAME WALL INSTALLATION

Figure 4 - Wall-Mounting Instructions

SEE UNIT DIMENSIONS, FIGURE 1, FOR ACTUAL DIMENSIONS

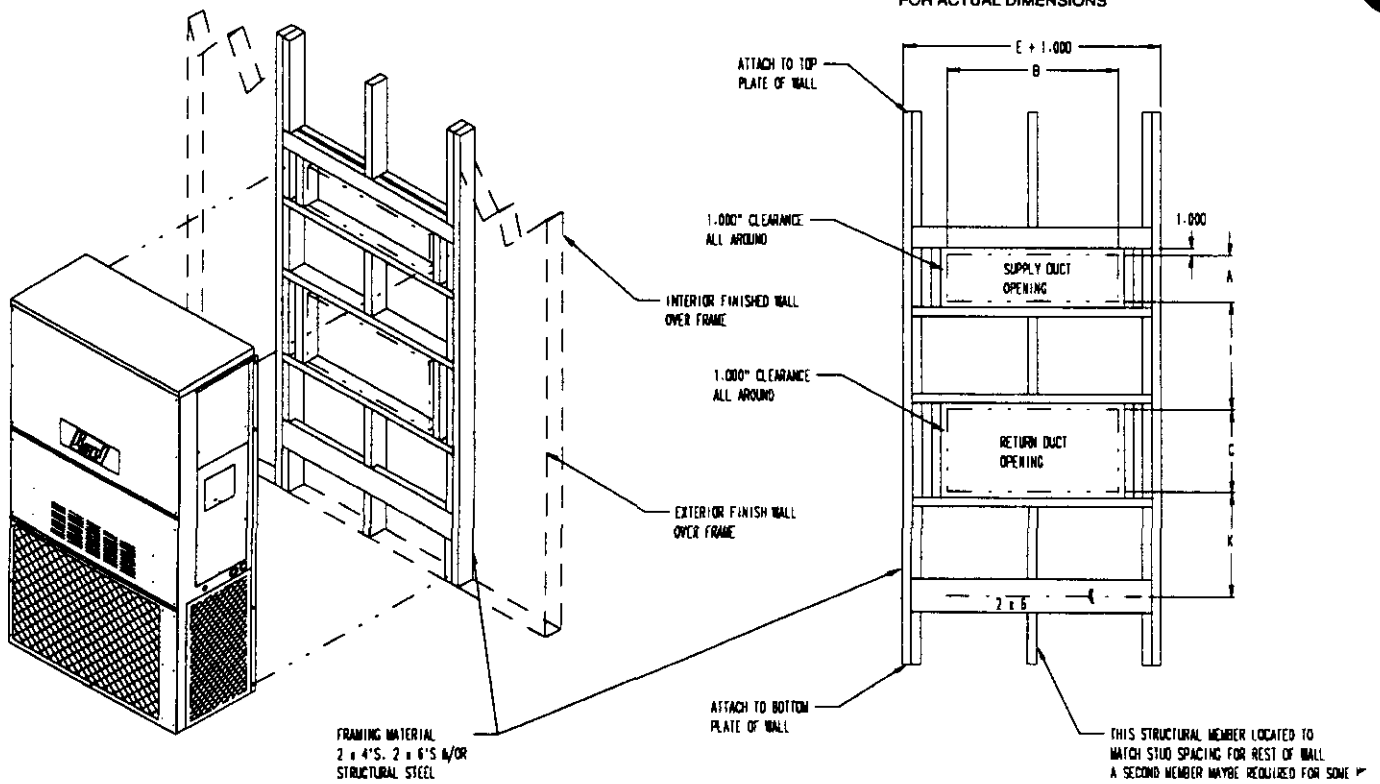
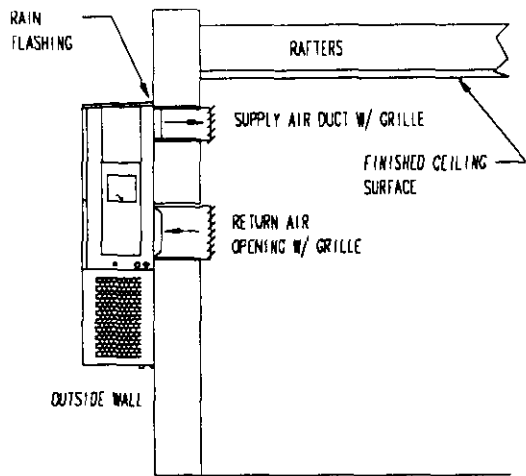
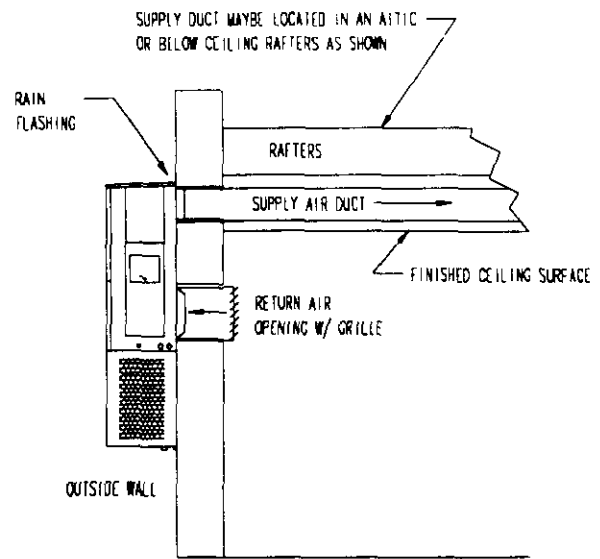

Figure 5 - Wall-Mounting Instructions



FREE AIR FLOW
NO DUCT



DUCTED SUPPLY
RETURN AT UNIT

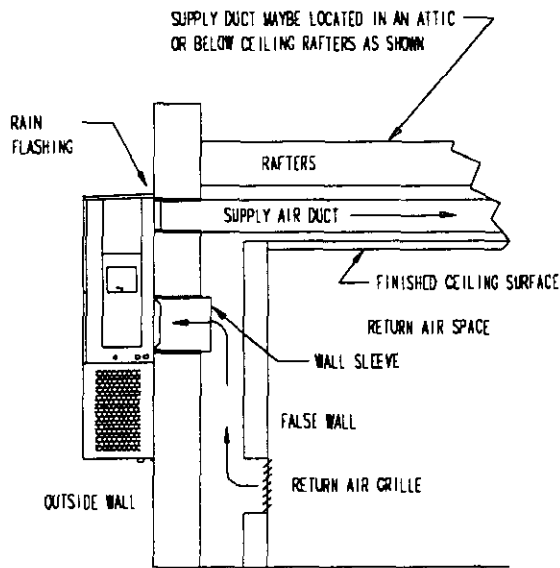

FALSE WALL INSTALLATION

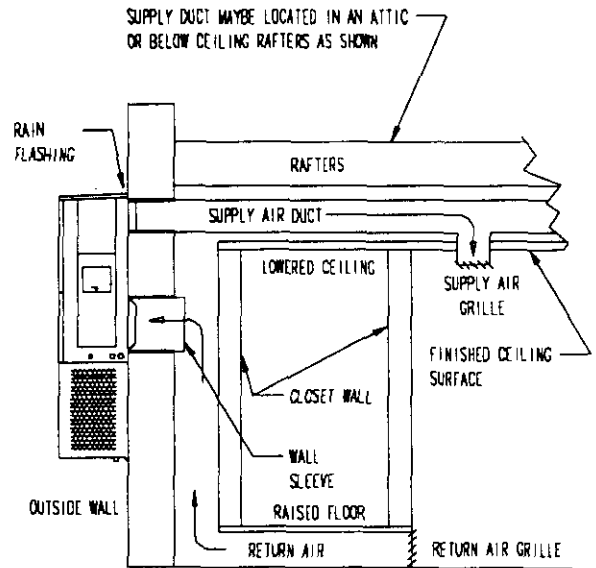

CLOSET INSTALLATION

Figure 6 — Common Wall-Mounting Installations

WIRING--MAIN POWER

Refer to the unit rating plate for wire sizing information and maximum fuse or "HACR Type" circuit breaker size. Each outdoor unit is marked with a "Minimum Circuit Ampacity". This means that the field wiring used must be sized to carry that amount of current. Depending on the installed KW of electric heat, there may be two field power circuits required. If this is the case, the unit serial plate will so indicate. All models are suitable only for connection with copper wire. Each unit and/or wiring diagram will be marked "Use Copper Conductors Only". These instructions MUST BE adhered to. Refer to the National Electrical Code (NEC) for complete current carrying capacity data on the various insulation grades of wiring material. All wiring must conform to NEC and all local codes.

The electrical data lists fuse and wire sizes (75°C copper) for all models, including the most commonly used heater sizes. Also shown are the number of field power circuits required for the various models with heaters.

The unit rating plate lists a "Maximum Time Delay Relay Fuse" or "HACR Type" circuit breaker that is to be used with the equipment. The correct size must be used for proper circuit protection and also to assure that there will be no nuisance tripping due to the momentary high starting current of the compressor motor.

The disconnect access door on this unit may be locked to prevent unauthorized access to the disconnect. To convert for the locking capability, bend the tab located in the bottom left hand corner of the disconnect opening under the disconnect access panel straight out. This tab will now line up with the slot in the door. When shut, a padlock may be placed through the hole in the tab preventing entry.

WIRING: LOW VOLTAGE WIRING

230/208V, 1 phase and 3 phase equipment dual primary voltage transformers. All equipment leaves the factory wired on 240V tap. For 208V operation, reconnect from 240V to 208V tap. The acceptable operating voltage range for the 240 and 208V taps are:

TAP	RANGE
240	253 - 216
208	220 - 187

NOTE: The voltage should be measured at the field power connection point in the unit and while the unit is operating at full load (maximum amperage operating condition).

Five (5) wires should be run from thermostat subbase to the 24V terminal board in the unit. A five conductor, 18 gauge copper, color-coded thermostat cable is recommended. The connection points are shown in Figure 7.

TABLE 3 THERMOSTAT WIRE SIZE

Transformer VA	FLA	Wire Gauge	Maximum Distance In Feet
55	2.3	20 Gauge	45
		18 "	60
		16 "	100
		14 "	160
		12 "	250

TABLE 3A WALL THERMOSTAT AND SUBBASE COMBINATIONS

Thermostat	Subbase	Predominate Features
8403-019	8404-012	1 stage cool, 2 stage heat
T874C1760	Q674A1001	System: heat-auto-cool Fan: on-auto
8403-002	8404-003	1 stage heat, 1 stage cool
T87F3111	Q539A1220	System: heat-off-cool Fan: on-auto
8403-009	----	1 stage heat, 1 stage cool
1F56-318		System: heat-off-cool Fan: on-auto
8403-035	----	2 stage cool, 2 stage heat
1F95-80		Programmable Electronic

Figure 7

LOW VOLTAGE WIRING

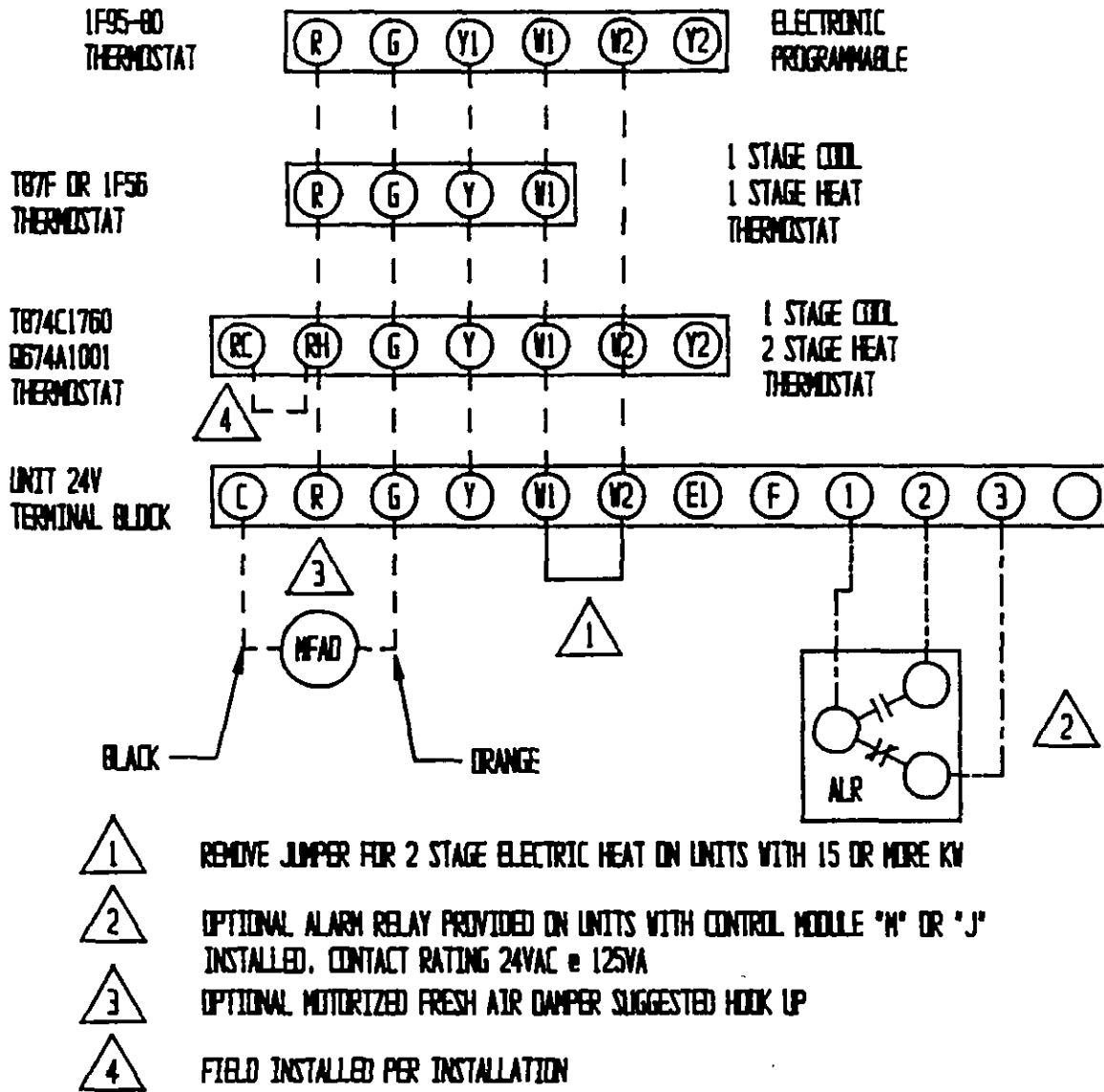

OPTIONAL ECONOMIZER LOW VOLTAGE WIRING

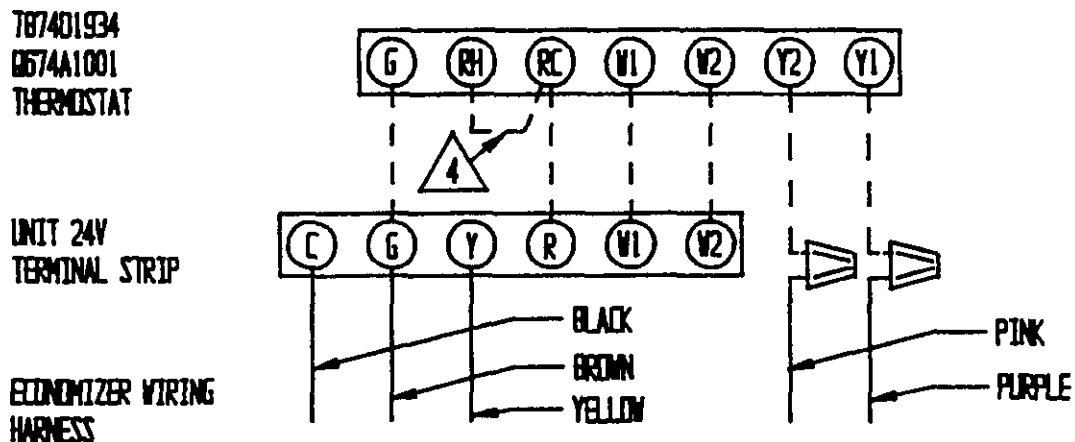

PART 3 -- START-UP

IMPORTANT INSTALLER NOTE

For improved start-up performance, wash the indoor coil with a dishwasher detergent.

CRANKCASE HEATERS

All units are provided with some form of compressor crankcase heat.

All single and three phase models have an insertion well-type heater located in the lower section of the compressor housing. This is a self-regulating type heater that draws only enough power to maintain the compressor at a safe temperature.

Some form of crankcase heat is essential to prevent liquid refrigerant from migrating to the compressor, causing oil pump out on compressor start-up and possible valve failure due to compressing a liquid.

The decal in Figure 8 is affixed to all outdoor units detailing start-up procedure. This is very important. Please read carefully.

FIGURE 8

IMPORTANT

These procedures must be followed at initial start-up and at any time power has been removed for 12 hours or longer.

To prevent compressor damage which may result from the presence of liquid refrigerant in the compressor crankcase.

1. Make certain the room thermostat is in the "off" position (the compressor is not to operate).
2. Apply power by closing the system disconnect switch. This energizes the compressor heater which evaporates the liquid refrigerant in the crankcase.
3. Allow 4 hours or 60 minutes per pound of refrigerant in the system as noted on the unit rating plate, whichever is greater.
4. After properly elapsed time, the thermostat may be set to operate the compressor.
5. Except as required for safety while servicing—Do not open system disconnect switch.

7961-061

SERVICE HINTS

1. Caution homeowner to maintain clean air filters at all times. Also, not to needlessly close off supply and return air registers. This reduces air flow through the system, which shortens equipment service life as well as increasing operating costs.
2. Check all power fuses or circuit breakers to be sure they are the correct rating.
3. Periodic cleaning of the outdoor coil to permit full and unrestricted airflow circulation is essential.

SEQUENCE OF OPERATION

COOLING--Circuit R-Y makes at thermostat pulling in compressor contactor, starting the compressor and outdoor motor. The G (indoor motor) circuit is automatically completed on any call for cooling operation or can be energized by manual fan switch on subbase for constant air circulation. On a call for heating, circuit R-W1 make at the thermostat pulling in heat contact for the strip heat and blower operation. On a call for second stage heat, R-W2 makes bringing on second heat contactor, if so equipped.

PRESSURE SERVICE PORTS

High and low pressure service ports are installed on all units so that the system operating pressures can be observed. Pressure curves can be found later in the manual covering all models. It is imperative to match the correct pressure curve to the unit by model number.

PART 4 -- TROUBLESHOOTING

FAN BLADE SETTING DIMENSIONS

Shown in the drawing below are the correct fan blade setting dimensions for proper air delivery across the outdoor coil.

Any service work requiring removal or adjustment in the fan and/or motor area will require that the dimensions below be checked and blade adjusted in or out on the motor shaft accordingly.

FIGURE 9

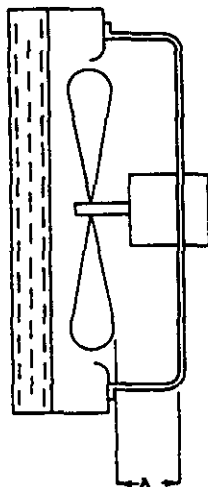

TABLE 4

Model	Dimension A
WA181	1.00
WA241	

REMOVAL OF THE FAN SHROUD

1. Disconnect all power to unit.
2. Remove the screws holding both grills--one on each side of unit--and remove grills.
3. Remove screws holding fan shroud to condenser and bottom, (9) screws.
4. Unwire condenser fan motor.
5. Slide complete motor, fan blade, and shroud assembly out the left side of the unit.
6. Service motor/fan as needed.
7. Reverse steps to reinstall.

REFRIGERANT CHARGE

The correct system R-22 charge is shown on the unit rating plate. Optimum unit performance will occur with a refrigerant charge resulting in a suction line temperature (6" from compressor) as shown in the following table:

TABLE 5

Model	Rated Airflow	95° F OD Temperature	82° F OD Temperature
WA181	650	51 - 53	63 - 65
WA241	800	61 - 63	63 - 65

The above suction line temperatures are based upon 80° F dry/bulb/67° F wet bulb (50 percent R.H.) temperature and rated airflow across the evaporator during cooling cycle.

TABLE 6 INDOOR BLOWER PERFORMANCE--CFM @ 230V

E.S.P. In H2O	WA181, WA241	
	230V	
	Dry	Wet
.0	1020	975
.1	960	905
.2	865	800
.3	820	735
.4	735	650
.5	615	535

TABLE 7

Model	Rated CFM*	Rated ESP*	Recommended Airflow Range
WA181	650	.40	575 - 725
WA241	800	.20	700 - 950

*Rated CFM and ESP on high speed tap.

MAXIMUM ESP OF OPERATION

TABLE 8 ELECTRIC HEAT ONLY

Model	ESP
A00	.50
WA181 A05	.50
WA241 A08	.50
B00	.50
WA241 B06	.50

Values shown are for units equipped with STD 1" throw-away filter or 1" washable filter. Derate ESP by .15 for 2" pleated filters.

TABLE 9

COOLING

Air Temperature Entering Outdoor Coil °F

Model	Return Air Temperature	Pressure	°	°	°	°	°	°	°	°	°
			75	80	85	90	95	100	105	110	115
WA181	75 deg. DB	Low Side	71	73	75	77	79	81	82	84	85
	62 deg. WB	High Side	194	208	223	238	253	268	284	299	315
	80 deg. DB	Low Side	76	78	80	83	84	86	88	90	91
	67 deg. WB	High Side	199	214	229	244	259	275	291	307	323
	85 deg. DB	Low Side	81	84	86	89	91	93	95	96	98
	72 deg. WB	High Side	206	221	237	253	268	285	301	318	334
WA241	75 deg. DB	Low Side	72	75	78	80	82	84	86	87	89
	62 deg. WB	High Side	198	214	230	246	261	276	291	305	319
	80 deg. DB	Low Side	74	77	80	82	84	86	88	90	91
	67 deg. WB	High Side	211	229	246	263	280	295	311	326	341
	85 deg. DB	Low Side	77	80	83	85	87	89	91	93	94
	72 deg. WB	High Side	227	246	265	283	300	318	334	351	367

Low side pressure \pm 2 PSIGHigh side pressure \pm 5 PSIG

Tables are based upon rated CFM (airflow) across the evaporator coil and should be found under section titled "Refrigerant Charge" elsewhere in manual. If there is any doubt as to correct operating charge being in the system, the charge should be removed, system evacuated, and recharged to serial plate instructions.

TABLE 10

OPTIONAL ACCESSORIES

Model	Description	W	W	W
		A	A	A
		1	2	2
		8	4	4
		1	1	1
		-	-	-
		A	A	B
BHWA24-A04	Heater Packages		X	
BHWA02-A05	Heater Packages	X	X	
BHWA02-A08	Heater Packages	X	X	
BHWA02-A10	Heater Packages	X	X	
BHWA24-B06	Heater Packages			X
BOP-2	Blank Off Plate	X	X	X
BFAD-2	Barometric Fresh Air Damper	X	X	X
MFAD-2	Motorized Fresh Air Damper	X	X	X
CRV-2	Classroom Ventilator With Exhaust	X	X	X
BIFM-2	Economizer With Exhaust	X	X	X
WERV-A2A	Energy Recovery Ventilator	X	X	X
CMA-1	High Pressure Control (HPC)	X	X	X
CMA-2	Low Pressure Control (LPC)	X	X	X
CMA-4	Low and High Pressure Control	X	X	X
CMA-5	Time Delay Relay (TDR)	X	X	X
CMA-6	Low Ambient Control (LAC)	X	X	X
CMA-8	TDR + HPC	X	X	X
CMA-10	LPC + HPC + TDR	X	X	X
CMA-11	LPC + HPC + LAC	X	X	X
CMA-12	LAC + TDR	X	X	X
CMA-13	LPC + HPC + TDR + LAC	X	X	X
CMC-15	Start Kit	X	X	
WMCB-02A	Circuit Breaker Kits	X	X	
WMCB-01B	Circuit Breaker Kits			X

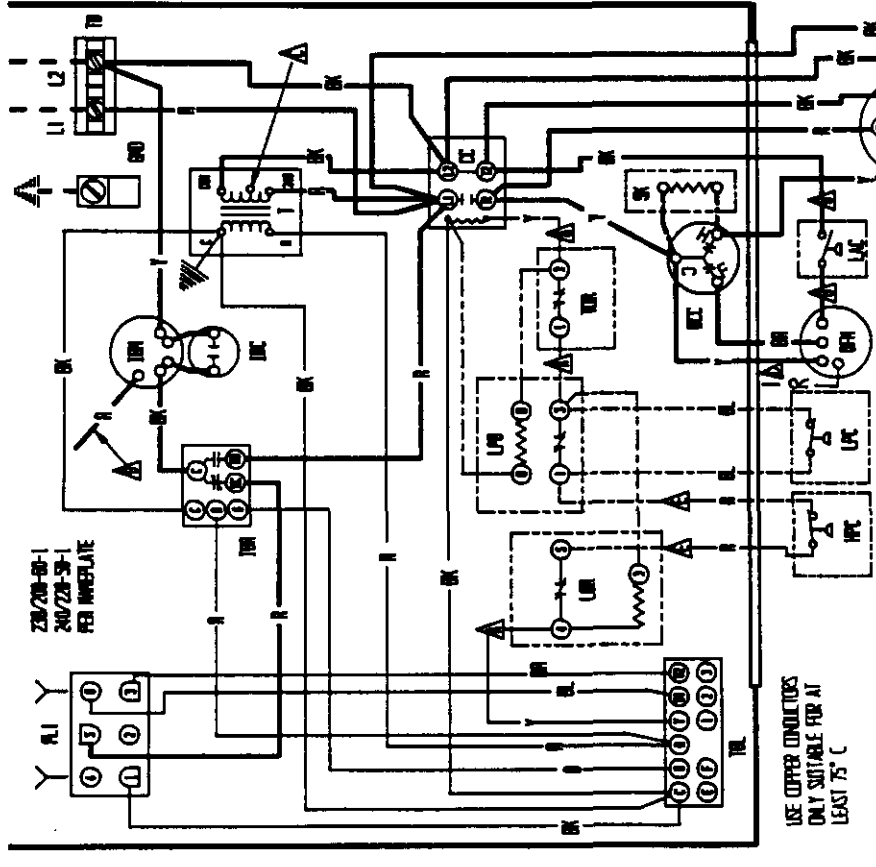
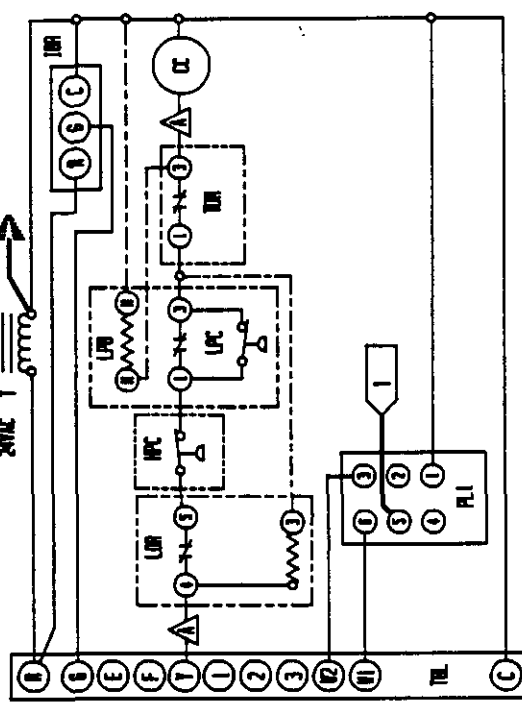
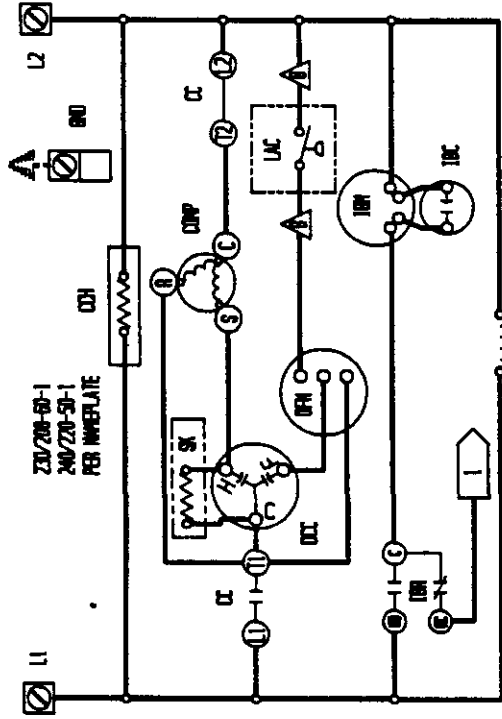

USE COPPER CONDUCTORS
ONLY SUITABLE FOR AT
LEAST 75° C

COMPONENT CODE	
CH1	CIRCUIT BREAKER #1
CH2	CIRCUIT BREAKER #2
CC	COMPRESSOR CONTACTOR
CH3	COMPRESSOR CONTACTOR HEATER
CH4	COMPRESSOR
CH5	DUAL CAPACITOR
CH6	EQUIPMENT GROUND
CH7	HEAT STRIP #1
CH8	HEAT STRIP #2
CH9	HEATER CONTACTOR #1
CH10	HEATER CONTACTOR #2
CH11	HIGH PRESSURE CONTROL
CH12	INDOOR BLOWER CAPACITOR
CH13	INDOOR BLOWER MOTOR
CH14	INDOOR BLOWER RELAY
CH15	LOW AMBIENT CONTROL
CH16	LOCK OUT RELAY
CH17	LOW PRESSURE BYPASS
CH18	LOW PRESSURE CONTROL
CH19	LIMIT SWITCH
CH20	OUTDOOR FAN MOTOR
CH21	PLUS #1
CH22	START KIT
CH23	TRANSFORMER
CH24	TERMINAL BLOCK
CH25	LOW VOLTAGE TERMINAL BLOCK
CH26	THERMAL CUTOFF
CH27	TIME RELAY RELAY

▲ ▲ ▲ LABELLED WIRES CORRECT IF NO OPTIONS USED. ▲ NONE RED WIRE TO 200V TAP FOR 200V OPERATION ▲ RED (LOW) BLACK (HIGH) WHERE APPLICABLE

COLOR CODE	
Y	YELLOW
V	VIOLET
G	GREEN
R	RED
B	BLUE
W	WHITE
OR	ORANGE
GR	GREEN
BL	BLACK
BR	BROWN
PK	PINK
SL	SLATE
LT	LAVENDER

BARB MFG. CO.
 DWG. 4085-110 C
 DRN. CSB
 CHK. APR.

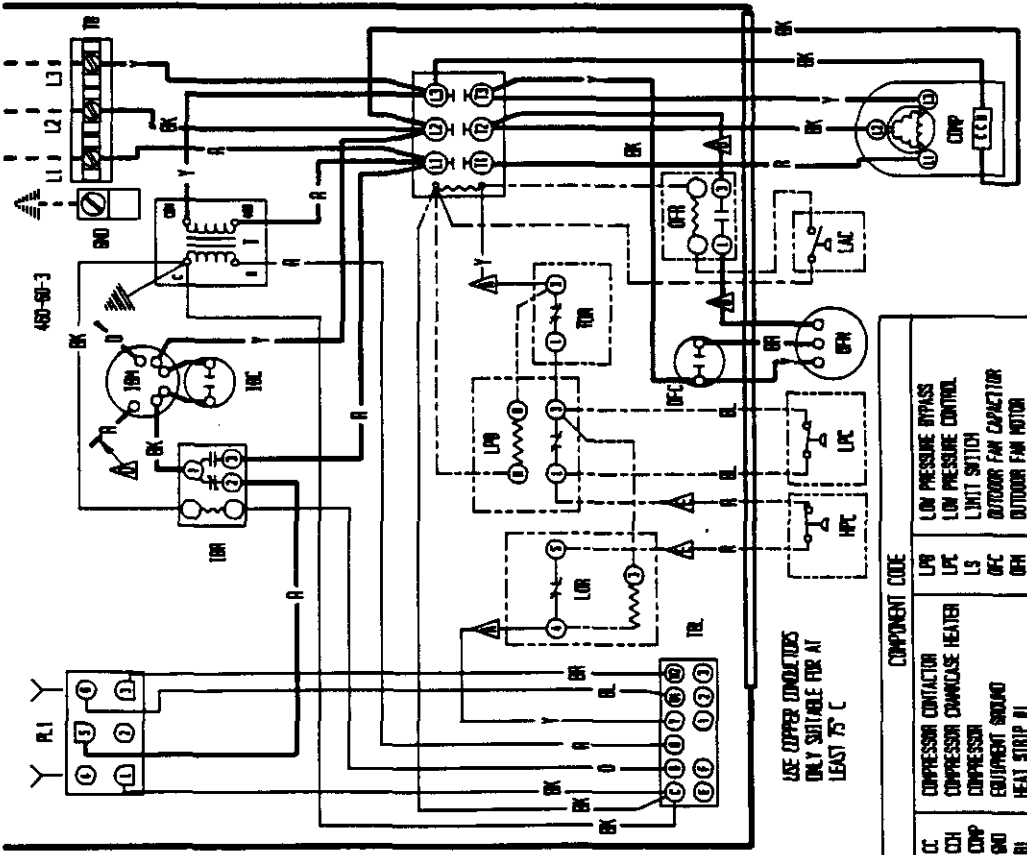
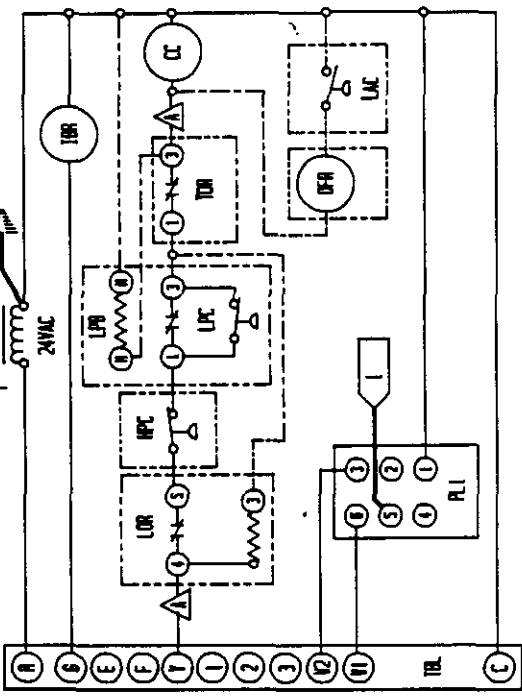
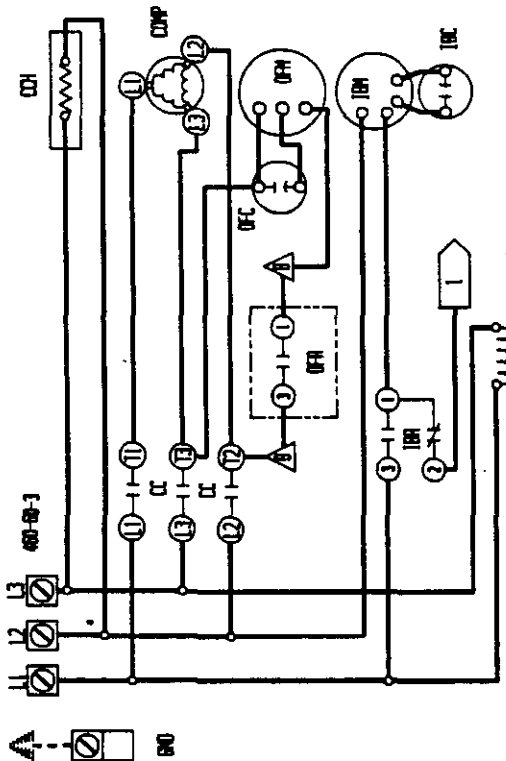

USE COPPER CONDUCTORS
ONLY SUITABLE FOR AT
LEAST 75 °C

COMPONENT CODE	
CC	COMPRESSOR CONTACTOR
COH	COMPRESSOR OVERHEAT HEATER
COMP	COMPRESSOR
ENQ	EQUIPMENT SOUND
HE1	HEAT STRIP #1
HE2	HEAT STRIP #2
HC1	HEATER CONTACTOR #1
HC2	HEATER CONTACTOR #2
HPC	HIGH PRESSURE CONTROL
IBL	INDOOR BLOWER CAPACITOR
IBM	INDOOR BLOWER MOTOR
IBR	INDOOR BLOWER RELAY
LAC	LOW AMBIENT CONTROL
LOR	LOCK OUT RELAY
LWP	LOW PRESSURE BYPASS
LPC	LOW PRESSURE CONTROL
LS	LOW PRESSURE SWITCH
OFC	OUTDOOR FAN CAPACITOR
OFM	OUTDOOR FAN MOTOR
OFR	OUTDOOR FAN RELAY
PO	PULL DISCONNECT
PL1	PLUG #1
T	TRANSFORMER
TR	TERMINAL BLOCK
TRBL	TERMINAL BLOCK
TV	LOW VOLTAGE TERMINAL BLOCK
TC	THERMAL CUTOFF
TRR	THERMAL RELAY
TRC	TIME DELAY RELAY

FACTORY NO.		FIELD		OPTIONAL	
WIND VOLTAGE	---	---	---	---	---
LOW VOLTAGE	---	---	---	---	---
NECESSARY	---	---	---	---	---

Labeled Wires Connect if no Options Used		Color Code	
OR	BLACK	Y	YELLOW
BR	BROWN	G	GREEN
R	RED	B	BLUE
D	ORANGE	W	WHITE
---	---	V	VIOLET
---	---	P	PURPLE
---	---	PK	PINK
---	---	L	LAVENDER

For Low Speed Connect Black and Orange Wires Together and Insulate. Connect Red Wire to Terminal 1 of TR			
TR	1	TRM	PINK
---	---	---	---
---	---	---	---

BARD MFG. CO.	
TRG	405-310 C
TRM	---
TRC	---
TRR	---

