

# **INSTALLATION INSTRUCTIONS**

## **WALL MOUNTED PACKAGE AIR CONDITIONERS**

### **MODELS**

**WA301**

**WA361**

MANUAL 2100-192 REV. A  
SUPERSEDES REV.  
FILE VOL. III, TAB 16

COPYRIGHT APRIL, 1989  
BARD MANUFACTURING COMPANY  
BRYAN, OHIO

## TABLE OF CONTENTS

Important . . . . .	3
Shipping Damage . . . . .	3
General . . . . .	3
Installation . . . . .	3
Duct Work . . . . .	3
Filter . . . . .	3
Fresh Air Intake . . . . .	4
Wall Mounting . . . . .	4
Mounting Instructions . . . . .	4
Low Voltage Wiring . . . . .	7
Wiring--Main Power . . . . .	7
Fan Blade Setting Dimensions . . . . .	7
Refrigerant Charge . . . . .	9
Pressure Service Ports . . . . .	10
Important Installer Note . . . . .	10
Crankcase Heaters . . . . .	10
Pressure Curve. . . . .	11
Optional Accessories . . . . .	12

## FIGURES AND TABLES

Figure 1 . . . . .	1
Figure 2 . . . . .	5
Figure 2A. . . . .	6
Figure 3 . . . . .	7
Figure 4 . . . . .	8
Figure 5 . . . . .	10
Table 1 . . . . .	2
Table 2 . . . . .	7
Table 3 . . . . .	7
Table 4 . . . . .	9
Table 5 . . . . .	9
Table 6 . . . . .	9
Table 7 . . . . .	10
Table 8 . . . . .	11
Table 9 . . . . .	12

FIGURE 1

SIZE SPECS FOR MIS-278

UNIT	WIDTH (W)	DEPTH (D)	HEIGHT (H)	SUPPLY		RETURN		E	F	G	I	J	K	L	M	N	O
				A	B	C	B										
18 & 24	32-7/8	16-7/8	70	7-7/8	20	11-7/8	20	34-7/8	18-1/4	25-3/4	20-3/4	26-3/4	28-3/4	29-1/4	27	2-9/16	34
30 & 36	37-7/8	16-7/8	70	7-7/8	28	13-7/8	28	39-7/8	18-1/4	25-3/4	18	26-3/4	28-3/4	29-1/4	27	2-9/16	39

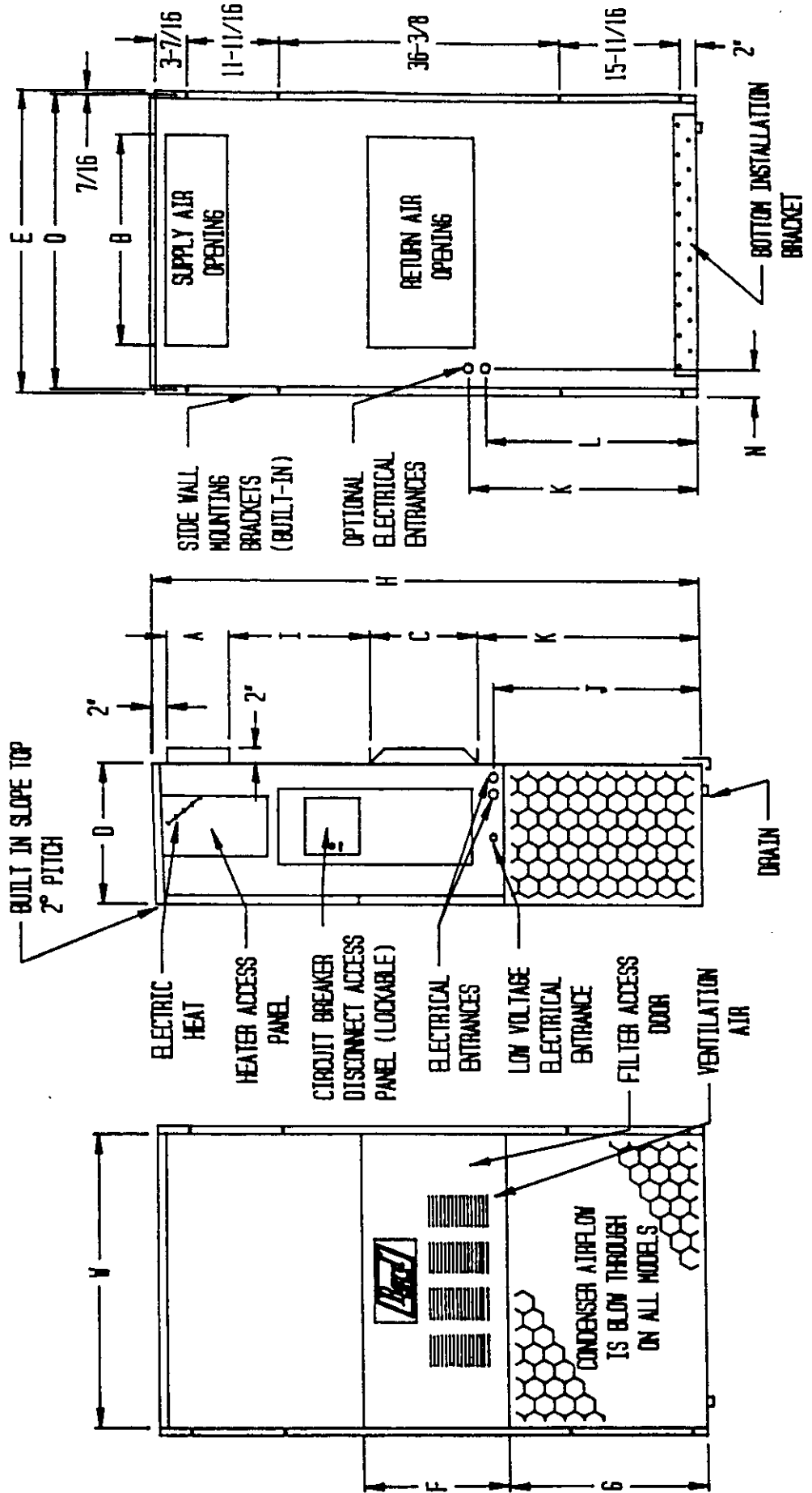

FRONT VIEW

SIDE VIEW

BACK VIEW

ELECTRICAL SPECIFICATIONS

TABLE 1

Model	Rated Volts and Phase	No. Field Power Ckts.	SINGLE CIRCUIT					DUAL CIRCUIT								
			Minimum Circuit Ampacity	(1) Maximum External Fuse Or Circuit Breaker	(2) Field Power Wire Size	(2) Ground Wire Size	Minimum Circuit Ampacity	Ckt A	Ckt B	(1) Maximum External Fuse Or Ckt. Breaker	Ckt A	Ckt B	(2) Field Power Wire Size	Ckt A	Ckt B	(2) Ground Wire Size
WA301-A00		1	22	35	10	10	N/A	N/A	N/A	N/A	N/A	N/A	N/A	N/A	N/A	N/A
A05		1	29	35	10	10	N/A	N/A	N/A	N/A	N/A	N/A	N/A	N/A	N/A	N/A
A08	230/208-1	1	45	45	8	10	N/A	N/A	N/A	N/A	N/A	N/A	N/A	N/A	N/A	N/A
A10		1	55	60	6	10	N/A	N/A	N/A	N/A	N/A	N/A	N/A	N/A	N/A	N/A
A15		1 or 2	81	90	4	8	55	26	60	30	4	10	8	10	10	10
WA301-B00		1	15	20	14	12	N/A	N/A	N/A	N/A	N/A	N/A	N/A	N/A	N/A	N/A
B06	230/208-3	1	21	25	10	10	N/A	N/A	N/A	N/A	N/A	N/A	N/A	N/A	N/A	N/A
B09		1	30	30	10	10	N/A	N/A	N/A	N/A	N/A	N/A	N/A	N/A	N/A	N/A
B15		1	48	50	8	10	N/A	N/A	N/A	N/A	N/A	N/A	N/A	N/A	N/A	N/A
WA301-C00		1	9	15	14	14	N/A	N/A	N/A	N/A	N/A	N/A	N/A	N/A	N/A	N/A
C06	460-3	1	11	15	14	14	N/A	N/A	N/A	N/A	N/A	N/A	N/A	N/A	N/A	N/A
C09		1	15	15	14	14	N/A	N/A	N/A	N/A	N/A	N/A	N/A	N/A	N/A	N/A
C15		1	24	25	10	10	N/A	N/A	N/A	N/A	N/A	N/A	N/A	N/A	N/A	N/A
WA361-A00		1	25	35	10	10	N/A	N/A	N/A	N/A	N/A	N/A	N/A	N/A	N/A	N/A
A05		1	29	35	10	10	N/A	N/A	N/A	N/A	N/A	N/A	N/A	N/A	N/A	N/A
A08	230/208-1	1	45	45	8	10	N/A	N/A	N/A	N/A	N/A	N/A	N/A	N/A	N/A	N/A
A10		1	55	60	6	10	N/A	N/A	N/A	N/A	N/A	N/A	N/A	N/A	N/A	N/A
A15		1 or 2	81	90	4	8	55	26	60	30	4	10	8	10	10	10
WA361-B00		1	18	25	12	10	N/A	N/A	N/A	N/A	N/A	N/A	N/A	N/A	N/A	N/A
B06	230/208-3	1	21	25	10	10	N/A	N/A	N/A	N/A	N/A	N/A	N/A	N/A	N/A	N/A
B09		1	30	30	10	10	N/A	N/A	N/A	N/A	N/A	N/A	N/A	N/A	N/A	N/A
B15		1	48	50	8	10	N/A	N/A	N/A	N/A	N/A	N/A	N/A	N/A	N/A	N/A
WA361-C00		1	9	15	14	14	N/A	N/A	N/A	N/A	N/A	N/A	N/A	N/A	N/A	N/A
C06	460-3	1	11	15	14	14	N/A	N/A	N/A	N/A	N/A	N/A	N/A	N/A	N/A	N/A
C09		1	15	15	14	14	N/A	N/A	N/A	N/A	N/A	N/A	N/A	N/A	N/A	N/A
C15		1	24	25	10	10	N/A	N/A	N/A	N/A	N/A	N/A	N/A	N/A	N/A	N/A

(1) Maximum size of the time delay fuse or HACR type circuit breaker for protection of field wiring conductors.

(2) Based on 75°C copper wire.

## **IMPORTANT**

The equipment covered in this manual is to be installed by trained, experienced service and installation technicians. Any heat pump is more critical of proper operating, charge and an adequate duct system than a straight air conditioning unit. All duct work supply and return, must be properly sized for the design air flow requirement of the equipment. ACCA is an excellent guide to proper sizing. All duct work or portions thereof not in the conditioned space should be properly insulated in order to both conserve energy and prevent condensation or moisture damage.

## **SHIPPING DAMAGE**

Upon receipt of equipment, the carton should be checked for external signs of shipping damage. If damage is found, the receiving party must contact the last carrier immediately, preferably in writing, requesting inspection by the carrier's agent.

## **GENERAL**

The refrigerant system is completely assembled and charged. All internal wiring is complete.

The unit is designed for use with or without duct work. Flanges are provided for attaching the supply and return ducts.

These instructions explain the recommended method to install the air cooled self-contained unit and the electrical wiring connections to the unit.

These instructions and any instructions packaged with any separate equipment required to make up the entire air conditioning system should be carefully read before beginning the installation. Note particularly "Starting Procedure" and any tags and/or labels attached to the equipment.

While these instructions are intended as a general recommended guide, they do not supersede any national and/or local codes in any way. Authorities having jurisdiction should be consulted before the installation is made.

## **INSTALLATION**

Size of unit for a proposed installation should be based on heat loss calculation made according to methods of Air Conditioning Contractors of America (ACCA). The air duct should be installed in accordance with the Standards of the National Fire Protection Association for the Installation of Air Conditioning and Ventilating systems of Other Than Residence Type, NFPA No. 90A, and Residence Type Warm Air Heating and Air Conditioning Systems, NFPA No. 90B. Where local regulations are at a variance with instructions, installer should adhere to local codes.

## **DUCT WORK**

Design the duct work according to methods given by the Air Conditioning Contractors of America. When duct runs through unheated spaces, it should be insulated with a minimum of one inch of insulation. Use insulation with a vapor barrier on the outside of the insulation. Flexible joints should be used to connect the duct work to the equipment in order to keep the noise transmission to a minimum.

A 1/4-inch clearance to combustible material for the first three feet of duct attached to the outlet air frame is required see page 5 for further details.

## **FILTER**

A one inch throwaway filter is supplied with each unit. The filter slides into position making it easy to service. This filter can be serviced from the outside by removing the service door. A 1-inch washable filter and 2-inch pleated filter are also available as optional accessories. The internal filter brackets are adjustable to accommodate the 2-inch filter.

## FRESH AIR INTAKE

All units are built with a fresh air inlet hole punched in the service panel.

The fresh air damper assembly is standard equipment with the unit because of the variety of state or local codes requiring fresh air capability. It is shipped already attached to each unit.

All capacity, efficiency and cost of operation information as required for Department of Energy "Energyguide" Fact Sheets is based upon the fresh air blank-off plate in place and is recommended for maximum energy efficiency.

The blank-off plate is available upon request from the factory and is installed in place of the fresh air damper shipped with each unit.

## WALL MOUNTING

1. Two holes, for the supply and return air openings must be cut through the wall as shown in Figure 2.
2. On wood-frame walls, the wall construction must be strong and rigid enough to carry the weight of the unit without transmitting any unit vibration. **WARNING:** Fire hazard can result if 1/4-inch clearance to combustible material for supply air duct is not maintained. See Figure 2.
3. Concrete block walls must be thoroughly inspected to insure that they are capable of carrying the weight of the installing unit.
4. Ducts through the walls must be insulated and all joints taped or sealed to prevent air or moisture entering the wall cavity.
5. Some installations may not require any return air duct. It is recommended that on this type of installation that a filter grille be located in the wall. Filters must be of sufficient size to allow a maximum velocity of 400 FPM.

**NOTE:** If no return air duct is used, applicable installation codes may limit this cabinet to installation only in a single story structure.

## MOUNTING INSTRUCTIONS

1. These units are secured by wall mounting brackets which secure the unit to the outside wall surface at both sides. A bottom mounting brackets is provided for ease of installation, but are not required.
2. The unit itself is suitable for "0" inch clearance, but the supply air duct flange and the first three feet of supply air duct require 1/4-inch clearance to combustible material. If combustible wall, use 28-1/2" x 8-1/2" dimensions for sizing, if non-combustible, use 28" x 8" dimensions.  
\*\*\*\*\*  
**WARNING:** Failure to provide the 1/4-inch clearance for the first three feet between the supply duct and a combustible surface can result in fire.  
\*\*\*\*\*
3. Locate and mark lag bolt locations and bottom mounting bracket location, if desired.
4. Mount bottom mounting bracket, if used.
5. Position unit in opening and secure with 5/16 lag bolts; use flat washers on the lag bolts.
6. For additional mounting rigidity, the return air and supply air (depending upon wall construction) frames or collars can be drilled and screwed or welded to the structural wall itself. Be sure to observe required clearance if combustible wall.
7. Maintain 30 inches minimum clearance on right side of unit to allow access to heat strip.

FIGURE 2

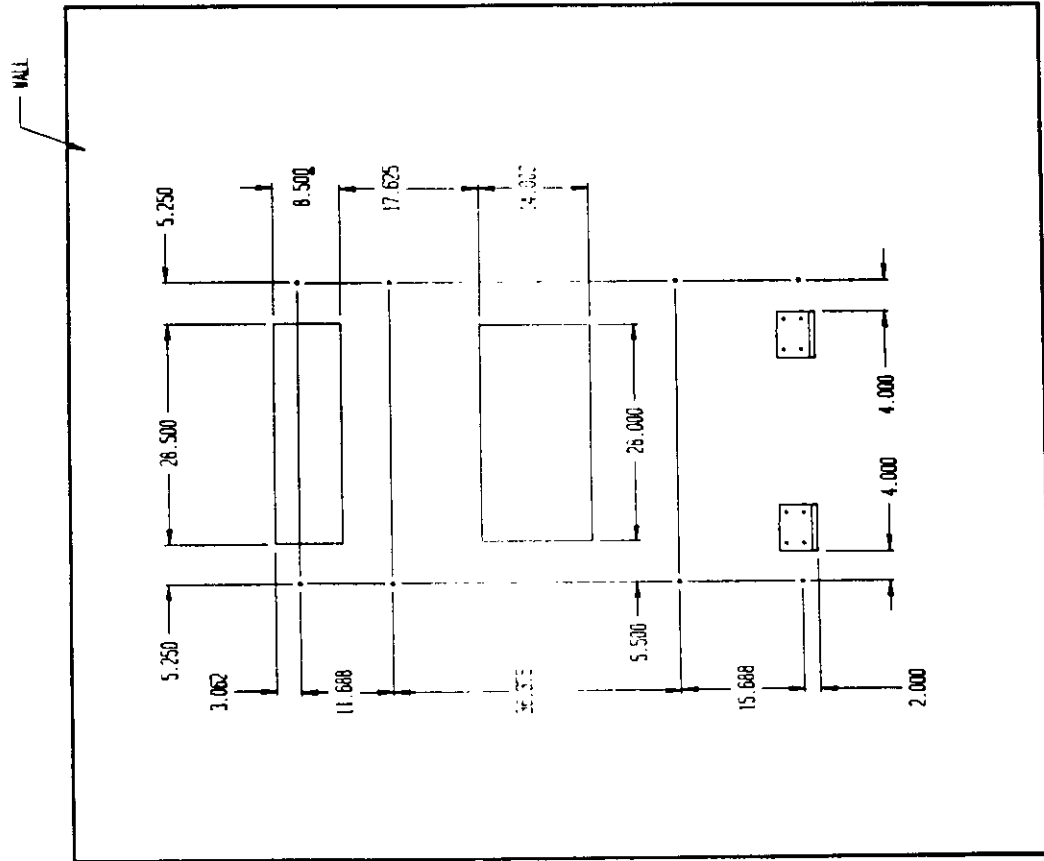
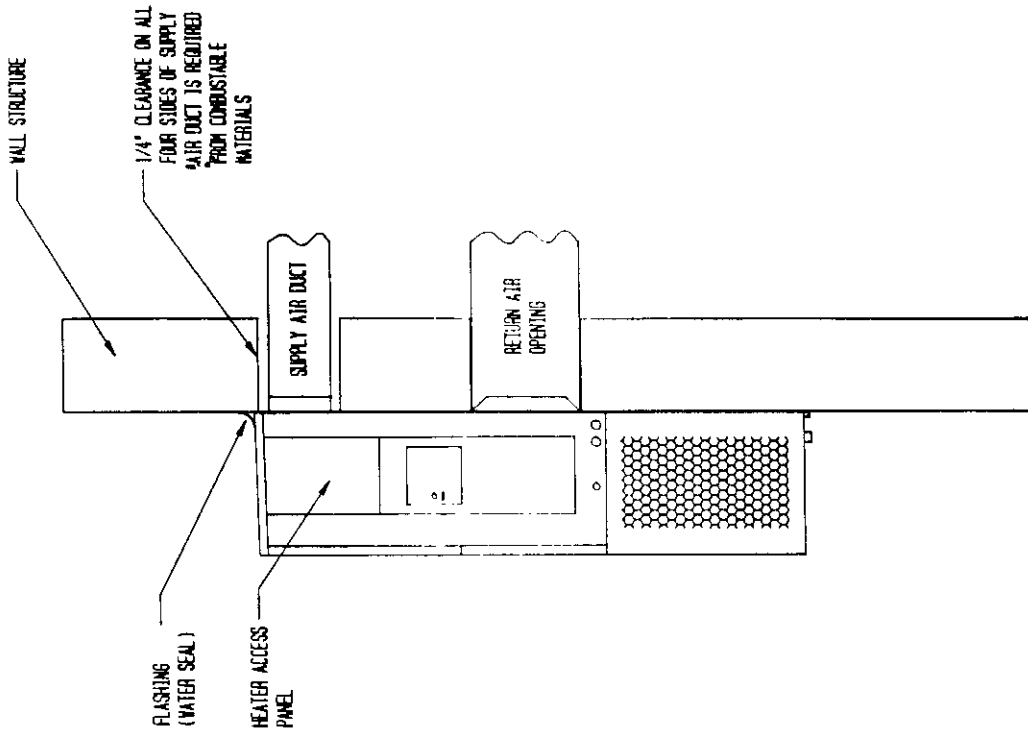
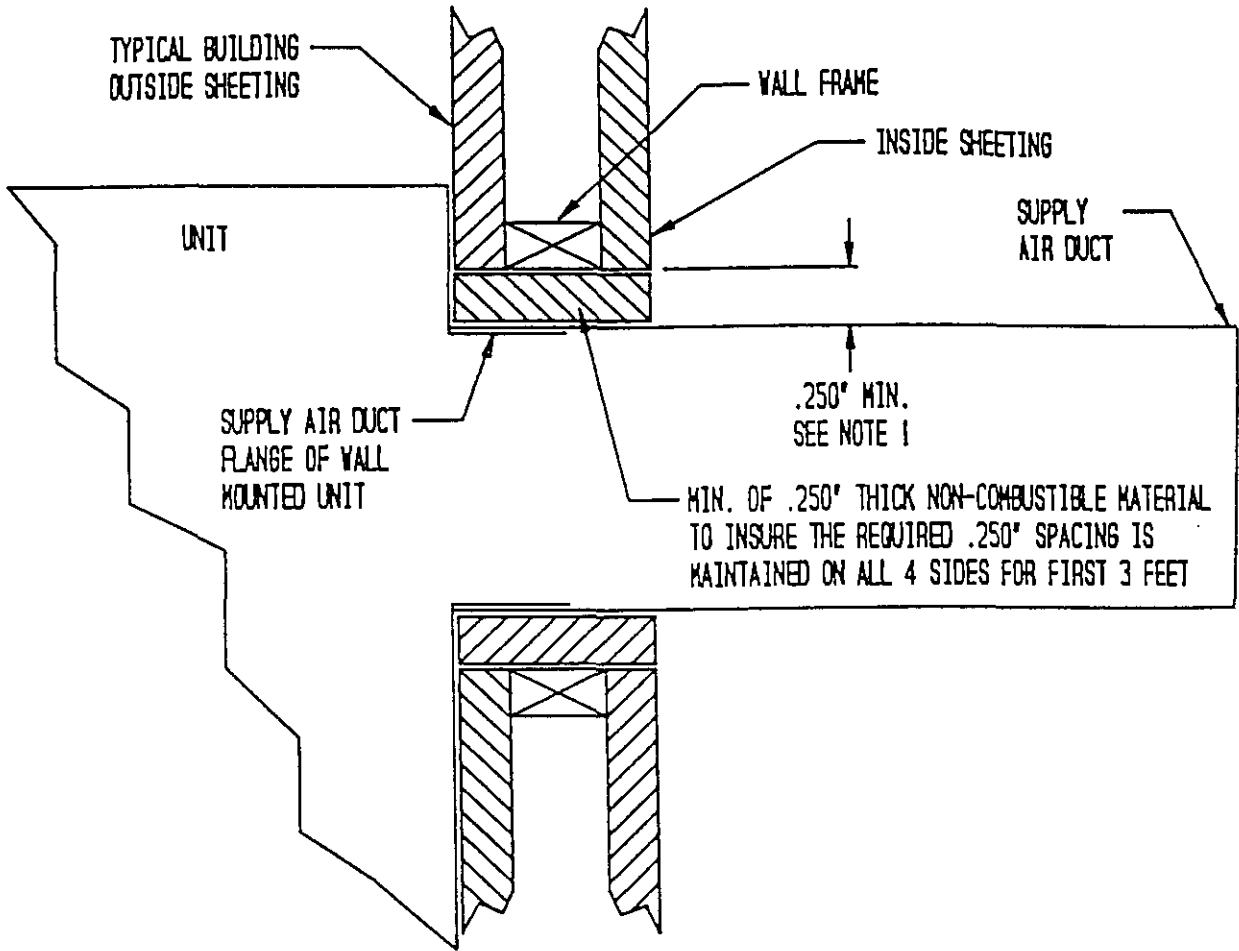



FIGURE 2A



Side section view of supply air duct for wall mounted unit showing 1/4" clearance to combustible surfaces.

WARNING

**NOTE 1:**

A minimum of 1/4" clearance must be maintained between the supply air duct and combustible materials. This is required for the first 3 feet of ducting.

It is important to insure that the 1/4" minimum spacing is maintained at all points. A suggested means of accomplishing that is with a 1/4" minimum thickness of non-combustible material as show.

Failure to do this could result in overheating the combustible material and may result in a fire.

The minimum clearance to combustibles is 1/4". Any clearance greater than this is acceptable and may ease installation. In every case, the 1/4" clearance to combustibles must be maintained.

## WIRING

### LOW VOLTAGE WIRING

A 24 volt terminal block is located in the lower left hand corner of the control panel. All low voltage thermostat connections should be made at these terminals. Wire size for the class 2 thermostat wire can be determined from the chart below.

TABLE 2

<u>Transformer VA</u>	<u>FLA @ 240</u>	<u>Wire Size</u>	<u>Maximum Distance In Feet</u>
40	1.6	20 Gauge	65
		18 "	90
		16 "	145
		14 "	230

See Figure 4 for applicable thermostat and subbase combinations and low voltage wiring information.

### WIRING--MAIN POWER

Refer to the unit rating plate for wire sizing information and maximum fuse or "HACR Type" circuit breaker size. Each outdoor unit is marked with a "Minimum Circuit Ampacity". This means that the field wiring used must be sized to carry that amount of current. Depending on the installed KW of electric heat, there may be two field power circuits required. If this is the case, the unit serial plate will so indicate. All models are suitable only for connection with copper wire. Each unit and/or wiring diagram will be marked "Use Copper Conductors Only". These instructions MUST BE adhered to. Refer to the National Electrical Code for complete current carrying capacity data on the various insulation grades of wiring material.

The electrical data lists fuse and wire sizes (75°C copper) for all models, including the most commonly used heater sizes. Also shown are the number of field power circuits required for the various models with heaters.

The unit rating plate lists a "Maximum Time Delay Relay Fuse" or "HACR Type" circuit breaker that is to be used with the equipment. The correct size must be used for proper circuit protection and also to assure that there will be no nuisance tripping due to the momentary high starting current of the compressor motor.

### FAN BLADE SETTING DIMENSIONS

Shown in the drawing below are the correct fan blade setting dimensions for proper air delivery across the outdoor coil.

Any service work requiring removal or adjustment in the fan and/or motor area will require that the dimensions below be checked and the blade adjusted in or out on the motor shaft accordingly.

FIGURE 3

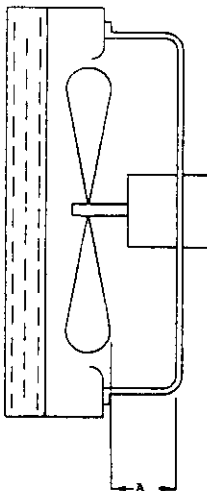
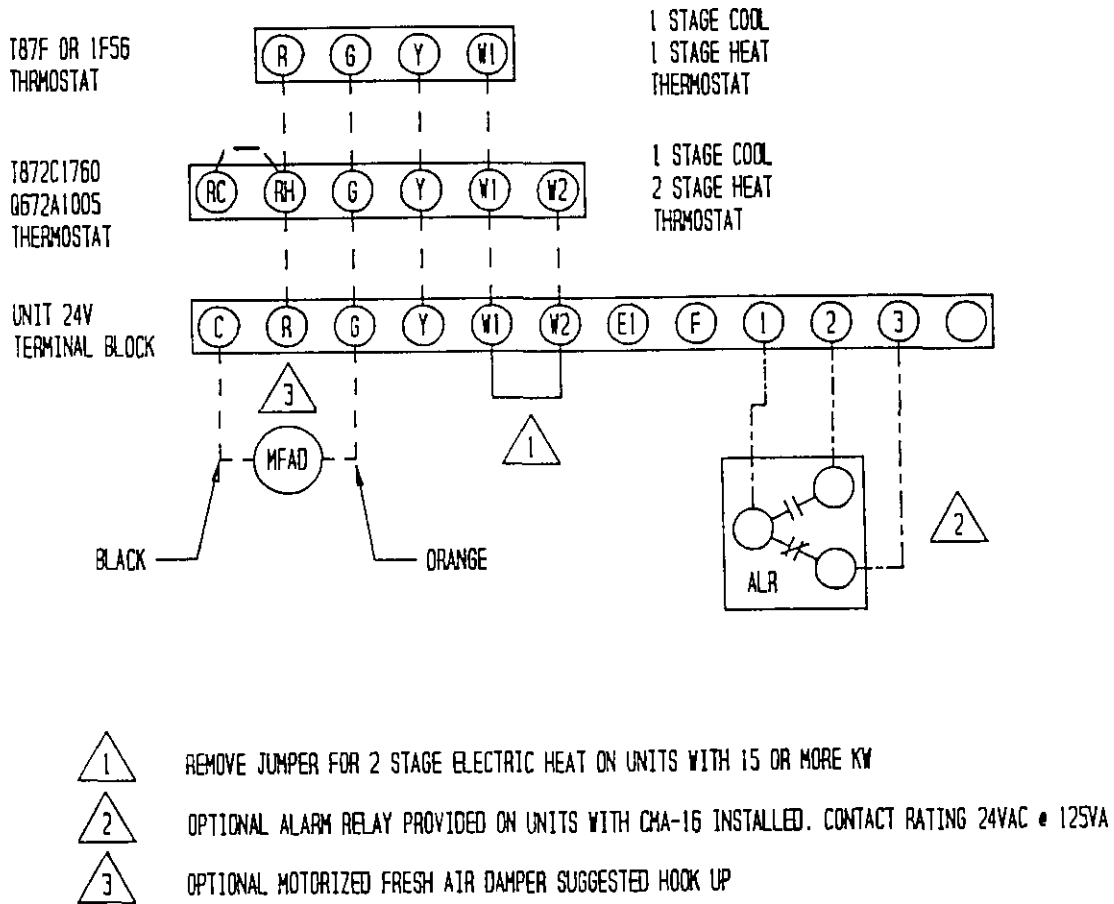

TABLE 3

Model	Dimension A
WA301	3/4
WA361	

FIGURE 4

LOW VOLTAGE WIRING



OPTIONAL ECONOMIZER LOW VOLTAGE WIRING

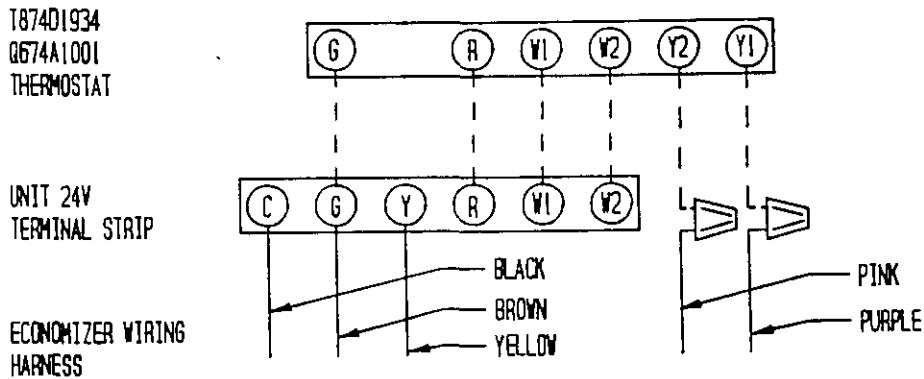

## REFRIGERANT CHARGE

The correct system R-22 charge is shown on the unit rating plate. Optimum unit performance will occur with a refrigerant charge resulting in a suction line temperature (6" from compressor) as shown in the following table:

TABLE 4

Model	Rated Airflow	95° F OD Temperature	82° F OD Temperature
WA301	1100	55 - 57	64 - 66
WA361	1100	57 - 59	62 - 64

The above suction line temperatures are based upon 80° F dry/bulb/67° F wet bulb (50 percent R.H.) temperature and rated airflow across the evaporator during cooling cycle.

TABLE 5 INDOOR BLOWER PERFORMANCE--CFM @ 230V

E.S.P. In H <sub>2</sub> O	WA301, WA361	
	Lo 230V	Hi 230V
	Dry/Wet Coil	Dry/Wet Coil
.0	950 / 935	1395 / 1315
.1	930 / 915	1340 / 1270
.2	910 / 885	1285 / 1190
.3	855 / 830	1205 / 1100
.4	---	1110 / 1000
.5	---	1005 / 870

## MAXIMUM ESP OF OPERATION

TABLE 6 ELECTRIC HEAT ONLY

Model	Low Speed	High Speed
A00	.50	.50
WA301 A05	.50	.50
WA361 A08	.50	.50
A10	.45	.50
A15	.35	.40
B00	.50	.50
WA301 B06	.40	.50
WA361 B09	.50	.50
B15	.30	.45
C00	.50	.50
WA301 C06	.50	.50
WA361 C09	.40	.50
C15	.35	.45

Values shown are for units equipped with STD 1" throw-away filter or 1" washable filter. Derate ESP by .15 for 2" pleated filters.

## PRESSURE SERVICE PORTS

High and low pressure service ports are installed on all units so that the system operating pressures can be observed. Pressure curves can be found later in the manual covering all models on both cooling and heating cycles. It is imperative to match the correct pressure curve to the unit by model number.

TABLE 7

Model	Rated CFM*	Rated ESP*	Recommended Airflow Range
WA301	1100	.30	930 - 1300
WA361	1100	.30	930 - 1350

\*Rated CFM and ESP on high speed tap.

## IMPORTANT INSTALLER NOTE

For improved start-up performance, wash the indoor coil with a dishwasher detergent.

## CRANKCASE HEATERS

All units are provided with an insertion well-type heater located in the lower section of the compressor housing. This is a self-regulating type heater that draws only enough power to maintain the compressor at a safe temperature.

Some form of crankcase heat is essential to prevent liquid refrigerant from migrating to the compressor, causing oil pump out on compressor start-up and possible valve failure due to compressing a liquid.

The decal in Figure 5 is affixed to all outdoor units detailing start-up procedure. This is very important. Please read carefully.

FIGURE 5

### **IMPORTANT**

**THESE PROCEDURES MUST BE FOLLOWED AT INITIAL START-UP AND AT ANY TIME POWER HAS BEEN REMOVED FOR 12 HOURS OR LONGER.**

TO PREVENT COMPRESSOR DAMAGE WHICH MAY RESULT FROM THE PRESENCE OF LIQUID REFRIGERANT IN THE COMPRESSOR CRANKCASE

1. MAKE CERTAIN THE ROOM THERMOSTAT IS IN THE "OFF" POSITION (THE COMPRESSOR IS NOT TO OPERATE).
2. APPLY POWER BY CLOSING THE SYSTEM DISCONNECT SWITCH THIS ENERGIZES THE COMPRESSOR HEATER WHICH EVAPORATES THE LIQUID REFRIGERANT IN THE CRANKCASE.
3. ALLOW 4 HOURS OR 60 MINUTES PER POUND OF REFRIGERANT IN THE SYSTEM AS NOTED ON THE UNIT RATING PLATE, WHICHEVER IS GREATER.
4. AFTER PROPERLY ELAPSED TIME THE THERMOSTAT MAY BE SET TO OPERATE THE COMPRESSOR.
5. EXCEPT AS REQUIRED FOR SAFETY WHILE SERVICING — DO NOT OPEN SYSTEM DISCONNECT SWITCH.

7961-061

**COOLING**

**TABLE 8**

**Air Temperature Entering Outdoor Coil °F**

Model	Return Air Temperature	Pressure	°	°	°	°	°	°	°	°	°
			75	80	85	90	95	100	105	110	115
WA301	75 deg. DB	Low Side	74	77	79	81	82	84	85	85	86
	62 deg. WB	High Side	218	232	247	262	277	292	308	325	341
	80 deg. DB	Low Side	80	82	84	86	88	89	91	91	92
	67 deg. WB	High Side	223	238	253	268	284	300	316	333	350
	85 deg. DB	Low Side	85	88	91	93	95	96	97	98	99
	72 deg. WB	High Side	231	246	262	278	294	310	327	345	362
WA361	75 deg. DB	Low Side	70	72	74	76	78	79	80	81	82
	62 deg. WB	High Side	224	242	259	275	290	304	316	328	339
	80 deg. DB	Low Side	75	77	79	81	83	85	86	87	88
	67 deg. WB	High Side	229	248	265	282	297	311	325	337	348
	85 deg. DB	Low Side	80	83	85	87	89	91	92	94	95
	72 deg. WB	High Side	238	257	275	292	307	322	336	349	360

Low side pressure  $\pm$  2 PSIG

High side pressure  $\pm$  5 PSIG

Tables are based upon rated CFM (airflow) across the evaporator coil and should be found under section titled "Refrigerant Charge" elsewhere in manual. If there is any doubt as to correct operating charge being in the system, the charge should be removed, system evacuated, and recharged to serial plate instructions.

TABLE 9

## OPTIONAL ACCESSORIES

Model	Description	W	W	W	W	W	W
		A	A	A	A	A	A
		3	3	3	6	6	6
		1	1	1	1	1	1
		-	-	-	-	-	-
		A	B	C	A	B	C
EHWA03-A05	Heater Packages	X			X		
EHWA03-A08	Heater Packages	X			X		
EHWA03-A10	Heater Packages	X			X		
EHWA03-A15	Heater Packages	X			X		
EHWA03-B06	Heater Packages		X			X	
EHWA03-B09	Heater Packages		X			X	
EHWA03-B15	Heater Packages		X			X	
EHWC03-C06	Heater Packages			X			X
EHWC03-C09	Heater Packages			X			X
EHWA03-C12	Heater Packages						X
EHWA03-C15	Heater Packages			X			X
BOP-3	Blank Off Plate	X	X	X	X	X	X
BFAD-3	Barometric Fresh Air Damper	X	X	X	X	X	X
MFAD-3	Motorized Fresh Air Damper	X	X	X	X	X	X
CRV-3	Classroom Ventilator With Exhaust	X	X	X	X	X	X
EIEFM-3	Economizer With Exhaust	X	X	X	X	X	X
CMA-1	High Pressure Control (HPC)	X	X	X	X	X	X
CMA-2	Low Pressure Control (LPC)	X	X	X	X	X	X
CMA-4	Low and High Pressure Control	X	X	X	X	X	X
CMA-5	Time Delay Relay (TDR)	X	X	X	X	X	X
CMA-6	Low Ambient Control (LAC)	X	X		X	X	
CMA-8	TDR + HPC	X	X	X	X	X	X
CMA-10	LPC + HPC + TDR	X	X	X	X	X	X
CMA-11	LPC + HPC + LAC	X	X		X	X	
CMA-12	LAC + TDR	X	X		X	X	
CMA-13	LPC + HPC + TDR + LAC + Alarm Relay	X	X		X	X	
CMA-14	LPC + HPC + LAC + Start Kit	X			X		
CMA-15	LPC + HPC + TDR + Start Kit	X			X		
CMA-16	LPC + HPC + TDR + LAC + Alarm Relay + Start Kit	X			X		
CMA-17	LAC + TDR + Start Kit	X			X		
CMA-22	Start Kit	X			X		

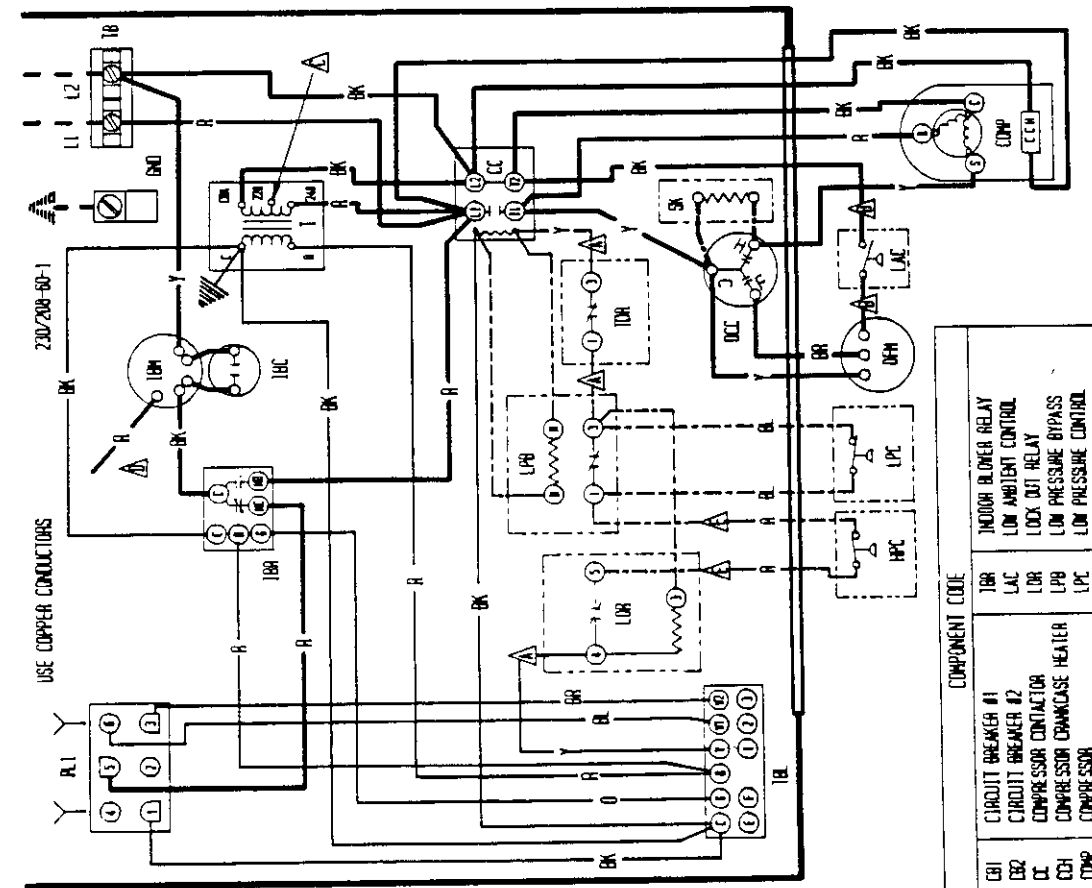
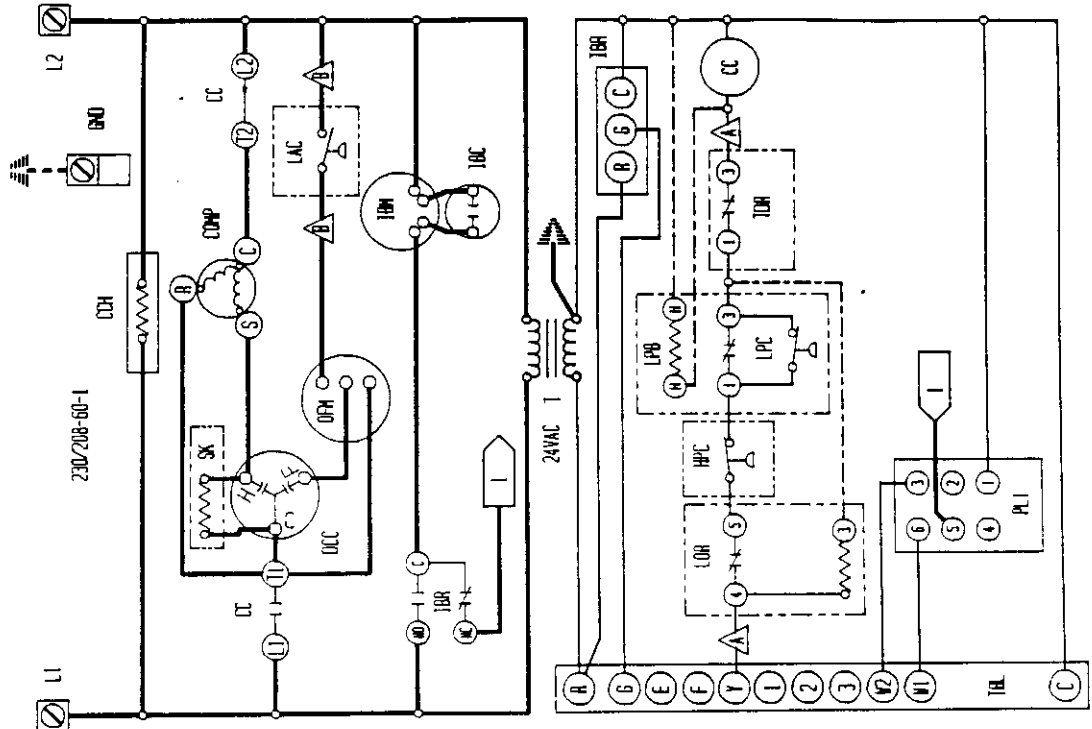

**USE COPPER CONDUCTORS**

**▲ ▲ ▲ LABELLED WIRES CONNECT IF NO OPTIONS USED.**    **▲** MOVE RED WIRE TO 208V TAP FOR 208V OPERATION    **▲** RED (LOW) BLACK (HIGH)

FACTORY STD.		FIELD	OPTIONAL
HIGH VOLTAGE	---	---	---
LOW VOLTAGE	---	---	---
ACCESSORY	---	---	---

COLOR CODE		T		V		Y		BK	
YELLOW	(PR)	PK	PK	YELLOW	PR	BLACK	BK	BLACK	BK
GREEN	BY	PK	PK	GREEN	BY	BROWN	BR	BROWN	BR
BLUE	(S)	L	L	BLUE	(S)	RED	R	RED	R
WHITE	(S)	S, STATE	S, STATE	WHITE	(S)	ORANGE	O	ORANGE	O

BARD MFG. CO.		RED (LOW) BLACK (HIGH)	
ENG.	4895-110	ENG.	4895-110
DRN.	CSB	DRN.	CSB
DK./APPR.	1-4	DK./APPR.	1-4

COMPONENT CODE	
CIRCUIT BREAKER #1	TBR
CIRCUIT BREAKER #2	LAC
COMPRESSOR CONTACTOR	LOR
COMPRESSOR COMPANCASE HEATER	LPB
COMPRESSOR	LPC
DUAL CAP CAPACITOR	LS
EQUIPMENT GROUND	DPH
HEAT STRIP #1	PL1
HEAT STRIP #2	SK
HEATER CONTACTOR #1	T
HEATER CONTACTOR #2	T8
HIGH PRESSURE CONTROL	TBL
INDOOR BLOWER CAPACITOR	ICD
INDOOR BLOWER RELAY	TBR



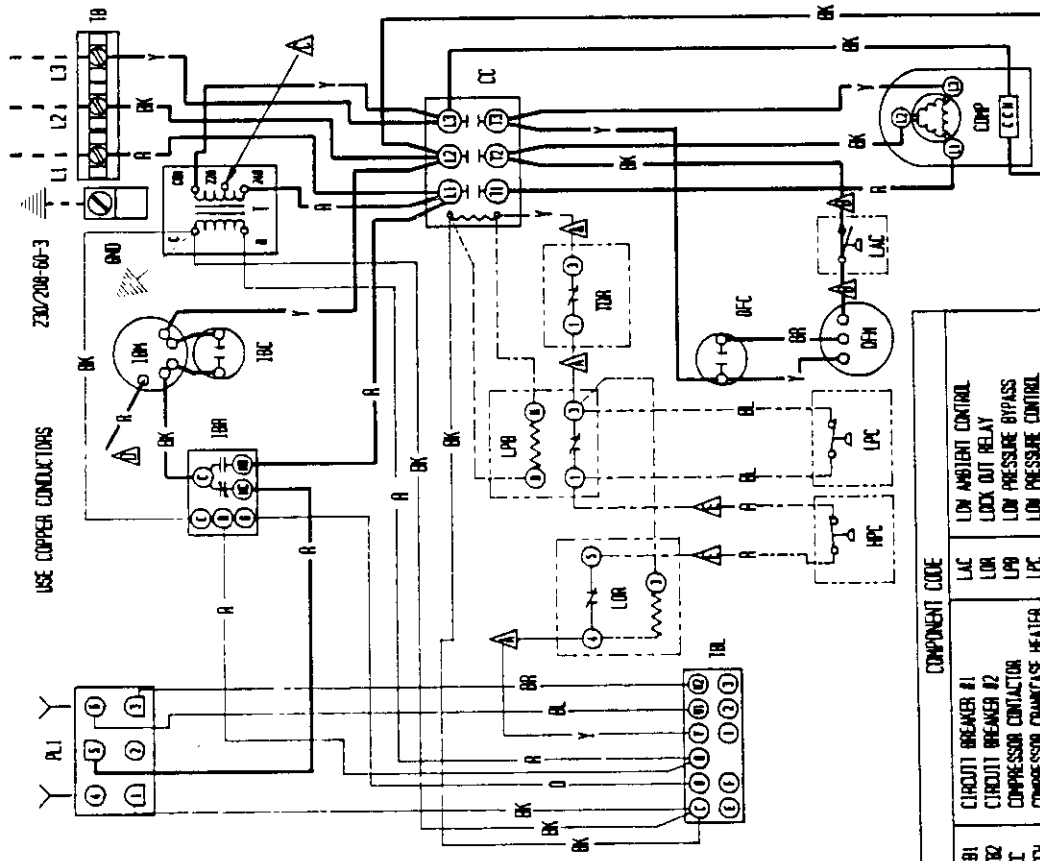
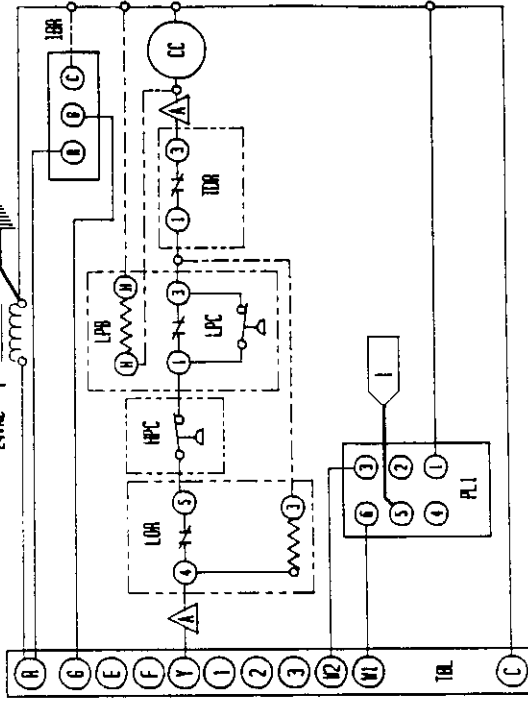
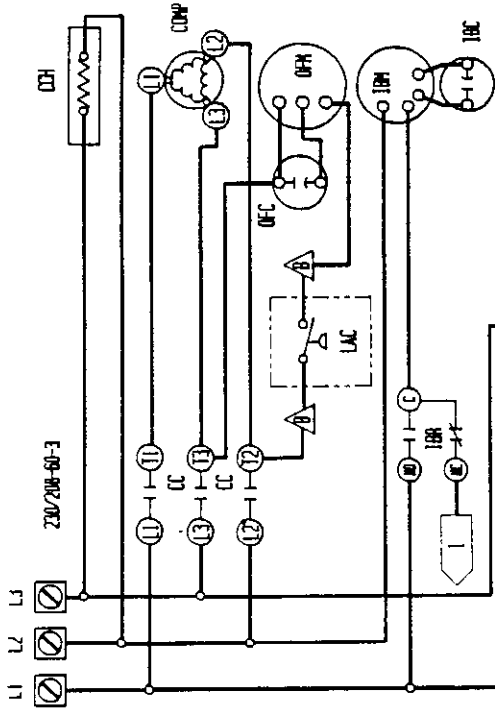

USE COPPER CONDUCTORS

COMPONENT CODE	
CB1	CIRCUIT BREAKER #1
CB2	CIRCUIT BREAKER #2
CC	COMPRESSOR CONTACTOR
CCA	COMPRESSOR CONTACTOR CASE HEATER
COMP	COMPRESSOR
GND	EQUIPMENT GROUND
H1	HEAT STRIP #1
H2	HEAT STRIP #2
HCL1	HEATER CONTACTOR #1
HCL2	HEATER CONTACTOR #2
HPC	HIGH PRESSURE CONTROL
IBC	INDOOR BLOWER CAPACITOR
IBM	INDOOR BLOWER MOTOR
IBR	INDOOR BLOWER RELAY
LAC	LOW AMBIENT CONTROL
LOC	LOCK OUT RELAY
LPP	LOW PRESSURE BYPASS
LPC	LOW PRESSURE CONTROL
LS	LIMIT SWITCH
OFC	OUTDOOR FAN CAPACITOR
OFA	OUTDOOR FAN MOTOR
PLUG #1	PLUG #1
SK	START KIT
T	TRANSFORMER
TB	TERMINAL BLOCK
TBL	LOW VOLTAGE TERMINAL BLOCK
TCD	TEMPERATURE DIFF
TOR	TIME DELAY RELAY

△ LABELLED WIRES CONNECT IF NO OPTIONS USED.

△ MOVE RED WIRE TO 208V TAP FOR 208V OPERATION

△ RED (LOW) BLACK (HIGH)

COLOR CODE	
Y	YELLOW
V	VIOLET
Y (PR)	YELLOW (PR)
PK	PINK
BL	BLUE
GR	GRAY
W	WHITE
OR	ORANGE
BR	BROWN
RD	RED
BLK	BLACK
L	LAVENDER

FACTORY STD.		OPTIONAL	
HIGH VOLTAGE	---	HIGH VOLTAGE	---
LOW VOLTAGE	---	LOW VOLTAGE	---
ACCESSORY	---	ACCESSORY	---

BARD HFC. CO.	
ENG.	40SS-210
DWH.	DBB
CHK./APPR.	---

