

INSTALLATION INSTRUCTIONS

MC91AE MASTER CONTROLLER

MC92AE MASTER CONTROLLER

DATE: 12-28-95

**MANUAL 2100-189 B
SUPERSEDES REV. A
FILE VOL. III, TAB 19**

TABLE OF CONTENTS

1.	Important	1
2.	Shipping Damage	1
3.	General	1
4.	Theory Of Operation	1
	A. Timer	1
	B. Alarm Circuits	1
	1. Power Loss Alarm	2
	2. High Temperature Alarm	2
	3. Low Temperature Alarm	2
	C. Thermostat	2
5.	Sequence Of Operation	2
	A. Cooling	2
	B. Heating	2
6.	Installation Instructions	3
	A. Unpacking	3
	B. High Voltage Field Wiring	3
	C. Low Voltage Field Wiring	3
	D. Alarm Circuit Wiring	3
	1. Power Loss Alarm	3
	E. Thermostat	4
7.	System Checkout And Adjustment	4
8.	Troubleshooting	5
	A. General	6
	B. Timer	6
	C. Unit #1 & Unit #2	7
	D. Power Loss.	8
	E. Low Temp Alarm.	9
	F. High Temp Alarm	10
	G. Low Voltage Connections with Economizer	11
9.	MC91AE Wiring Diagram	12
10.	MC92AE Wiring Diagram	13
11.	Component Locations	14

IMPORTANT

The equipment covered in this manual is to be installed by trained, experienced service and installation technicians. Please read entire manual before proceeding.

SHIPPING DAMAGE

Upon receipt of equipment, the carton should be checked for external signs of shipping damage. If damage is found, the receiving party must contact the last carrier immediately, preferably in writing, requesting inspection by the carrier's agent.

GENERAL

These instructions explain the operation, installation and troubleshooting of the MC91A and MC92A controllers.

All internal wiring is complete. Only attach low voltage field wiring to designated terminal strips.

The controller is for use with Bard air conditioning wall mount series units only. The air conditioner units must be identical without economizers. The MC91A and MC92A are only for use without economizers. The MC91AE should be used for units with economizers.

Each unit should be sized to handle the total load of the structure.

It is recommended that a (5) five min. compressor time delay relay be installed in each unit.

THEORY OF OPERATION

The MC91A and MC92A are used to control two wall mount air conditioners from one thermostat. It provides total redundancy for the structure and equal wear on both units. It is used without economizers on the air conditioner units. It is not for use with heat pumps.

TIMER

The timer is a 24 hour or 7 day on/off timer. The changeover period is user selectable. Once every period the timer contacts switch positions. This determines which unit will be the primary unit and which will be the secondary unit for the next period. At the end of this period, the contacts switch again and the primary unit becomes the secondary unit and vice versa. Every 24 hours or 7 days the primary and secondary units switch providing equal wear on the units. This is done by energizing or de-energizing relays R1 and R2 every 24 hours. For 24 hour operation, connect jumper between pins 6 and 7. For 7 day operation, connect jumper between pins 6 and 4. for timer speed up, remove jumper. Replace jumper after controller has switched. Timer speed up is supplied for ease of troubleshooting.

ALARM CIRCUITS

The MC91A and MC92A are equipped with four (4) alarm circuits: power loss alarm, high temperature alarm, low temperature alarm, and second stage cooling alarm.

All alarm circuits have both normally open and normally closed dry contacts.

Power Loss Alarm

The power loss alarm relay, R6, is normally energized. Upon power loss to the MC91AE and MC92AE, the relay will de-energize and switch contact positions sending the alarm.

High Temperature Alarm

The high temperature alarm thermostat energizes the high temperature alarm relay, R4, and an interlock relay, (R3), that ensures that both units are on line if the high temperature alarm thermostat setpoint is exceeded.

Low Temperature Alarm

The low temperature thermostat energizes the low temperature alarm relay, R5, if the temperature of the structure drops below the low alarm thermostat setpoint.

THERMOSTAT

As in normal installations, the thermostat is the primary control of the room conditions. The thermostat is equipped with a heating setpoint lever, cooling setpoint lever, system off-auto switch, and fan switch. The fan switch is unused and should be left in the auto position.

SEQUENCE OF OPERATION

COOLING

1. On a call for first stage cooling, the blower and economizer of the primary unit is energized.
2. On a call for second stage cooling, the compressor and fans of the primary unit are energized and the economizer is de-energized.
3. If the high alarm setpoint is exceeded, the high alarm relay is energized, sending an alarm, and the interlock relay is energized which brings on the compressor and fan of the secondary unit.
4. (MC92AE only) In the event of compressor failure in both air conditioners, the lockout relays in these air conditioners close energizing the alarm relays dry contacts terminal 2-3. This closes circuit M-J in the MC92AE and energizes relay R13. R13 contacts close circuits E-F in the economizers and the economizers open maintaining a 55° entering air temperature until Y1 is satisfied.

HEATING

1. On a call by the thermostat for first stage heat, the electric heat in the primary unit will be energized.
2. On a call by the thermostat for second stage heat, the electric heat of the secondary unit will be energized.
3. If the temperature continues to fall and the low alarm setpoint is exceeded, the low temperature alarm relay is energized and an alarm is set.

INSTALLATION INSTRUCTIONS

UNPACKING

1. Included in the MC91AE and MC92AE carton are two packages: 1. The T874D1868 thermostat, and 2. the MC91AE or MC92AE controller. The thermostat subbase is installed on the controller.

Set aside the thermostat for now as it will be installed last.

2. The MC91AE and MC92AE should be installed on a vertical wall approximately four (4) feet above the floor away from drafts and outside doors or windows. Four (4) mounting holes are provided for mounting to the wall and holes for conduit connections are provided in both the base and top of the controller. The MC91AE and MC92AE should not be mounted directly to a block wall, space away from wall with insulation or plywood.

IMPORTANT: The subbase and thermostat must be level for proper operation.

HIGH VOLTAGE FIELD WIRING

No phasing is required between units on the MC91AE or MC92AE. The master controller requires a 120, 208 or 240 volt power supply. The unit is wired for 240 volt operation. See wiring diagram for wiring change required for 208 or 120 volt operation.

Connect the high voltage wiring per the diagram in Figure 2.

LOW VOLTAGE FIELD WIRING

Connect the low voltage field wiring from each unit per the low voltage field wiring diagrams in Figure 1.

For continuous blower operation, jumper R to G at the low voltage terminal block of the unit, and remove the jumper from Y1 to G on the low voltage terminal block of the master controller, both units.

ALARM CIRCUIT WIRING

All alarm circuit contacts are dry contacts. Maximum contact ratings:

125 VA @ 125 VAC
Pilot Duty Rating

Do not exceed these ratings when wiring your alarm circuit application. Contacts should be used for low voltage applications only.

Power Loss Alarm

Terminal identifications on the power loss alarm circuit represent contact positions in the normal power-on operating condition. When wiring the power loss alarm with no power applied, the contact positions will be opposite of terminal identifications.

THERMOSTAT

Do not install the thermostat until all low voltage connections have been made to the controller and the wiring has been checked for accuracy.

Remove the thermostat from the box. It should include:

- A. Thermostat T874D1868
- B. Instructions

1. Read the thermostat instructions before proceeding.
2. Remove the thermostat cover by pulling outward on the bottom of the cover.
3. Remove thermostat interpacking.
4. Position thermostat heat lever to far left.
5. Position thermostat cool lever to far right.
6. Position subbase system switch to off.
7. Position subbase fan switch to auto.
8. Install thermostat on subbase per the manufacturer's instructions.
9. Install lever locking assembly per instructions supplied with the thermostat.

This completes installation of the master controller.

SYSTEM CHECKOUT ADJUSTMENT

Refer to Figure 3 for component locations.

1. Turn high alarm thermostat to off. Turn low alarm thermostat to off.
2. Thermostat system and fan switches should be off, the thermostat heating lever should be to the far left and the cooling lever to the far right.
3. Apply power to both units, apply power to the master controller.
4. Follow initial start up procedures on side of wall mount unit.

Failure to follow these procedures may result in compressor failure.

5. Temporarily remove the wire from terminal 1 of the timer. See Figure 3.
6. Perform economizer checkout on unit #1 at this time as detailed in the economizer installation instructions with these exceptions.
 - A. The instructions request the manual fan switch position in Step B. This is a non-functional switch on the master controller. To simulate this, remove the factory installed jumper between G and Y1 on the Unit 1 low voltage block (temporarily). Install jumper from R to G and proceed with economizer checkout of primary unit. See Figure 1.
 - B. In Step G when asked to switch thermostat control to automatic, remove the jumper from R to G and replace the G to Y1 jumper on the Unit 1. Finish economizer checkout, then proceed to Step 7.

7. Move heating lever slowly to the right until first stage heating is engaged. The electric heat and blower of Unit 1 should come on.

Move heating lever further to the right to engage second stage heat. The electric heat and blower of Unit 2 should come on.

Reset heating lever to left.

8. Place a jumper between terminal 2 of the timer and the wire removed from terminal 1 of the timer.

Repeat Steps 6 through 7 replacing the phrase, "Unit 1" with "Unit 2" and vice versa.

9. Remove jumper and reattach the wire to terminal 1 of the timer.

10. Adjust low alarm thermostat setpoint to a temperature above room temperature. The low alarm circuit should activate if employed. Return low alarm thermostat to desired setpoint. In operation, this must be at least 5° below the desired heating lever setpoint. Failure to set alarm thermostat setpoint 5° below the thermostat setpoint could result in nuisance tripping of alarm circuit.
11. Adjust the high alarm setpoint to a temperature below room temperature. If employed, the high alarm circuit should be activated. Return high alarm thermostat to the desired setpoint. In operation, this must be at least 5° above the cooling lever setpoint. Failure to set alarm thermostat setpoint at least 5° above thermostat setpoint could result in nuisance tripping of alarm circuit.
12. Set heating and cooling temperature levers to the desired operating setpoints. Check the high alarm thermostat setpoint to make sure that it is at least 5° above the first stage cooling setpoint temperature. Check the low alarm thermostat to make sure it is at least 5° below the first stage heating setpoint temperature. Failure to set alarm thermostats correctly could result in nuisance tripping of alarm circuit.

13. Set thermostat heat anticipators per directions in thermostat instructions. Move thermostat system switch to off.
14. Remove jumper between terminals 6 and 7 of timer. Relays 1 and 2 should be heard switching approximately every 10 seconds. This indicates proper timer function. Replace jumper. Move thermostat system switch to AUTO.

This completes system checkout.

TROUBLESHOOTING

The troubleshooting section is divided into four sections.

1. General
2. Timer
3. Units
4. Alarm Circuits

Always perform general troubleshooting section before performing any other section.

GENERAL TROUBLE SHOOTING PROCEDURES

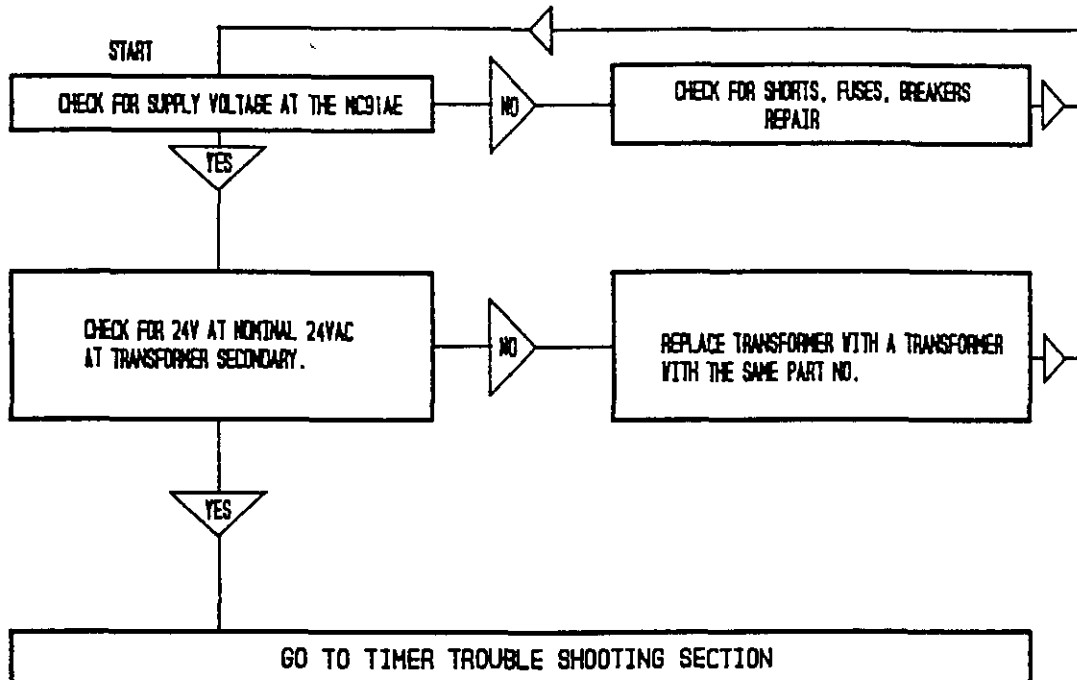

TIMER SECTION - TROUBLE SHOOTING THE TIMER AND ITS RELATED RELAYS (R1) & (R2)

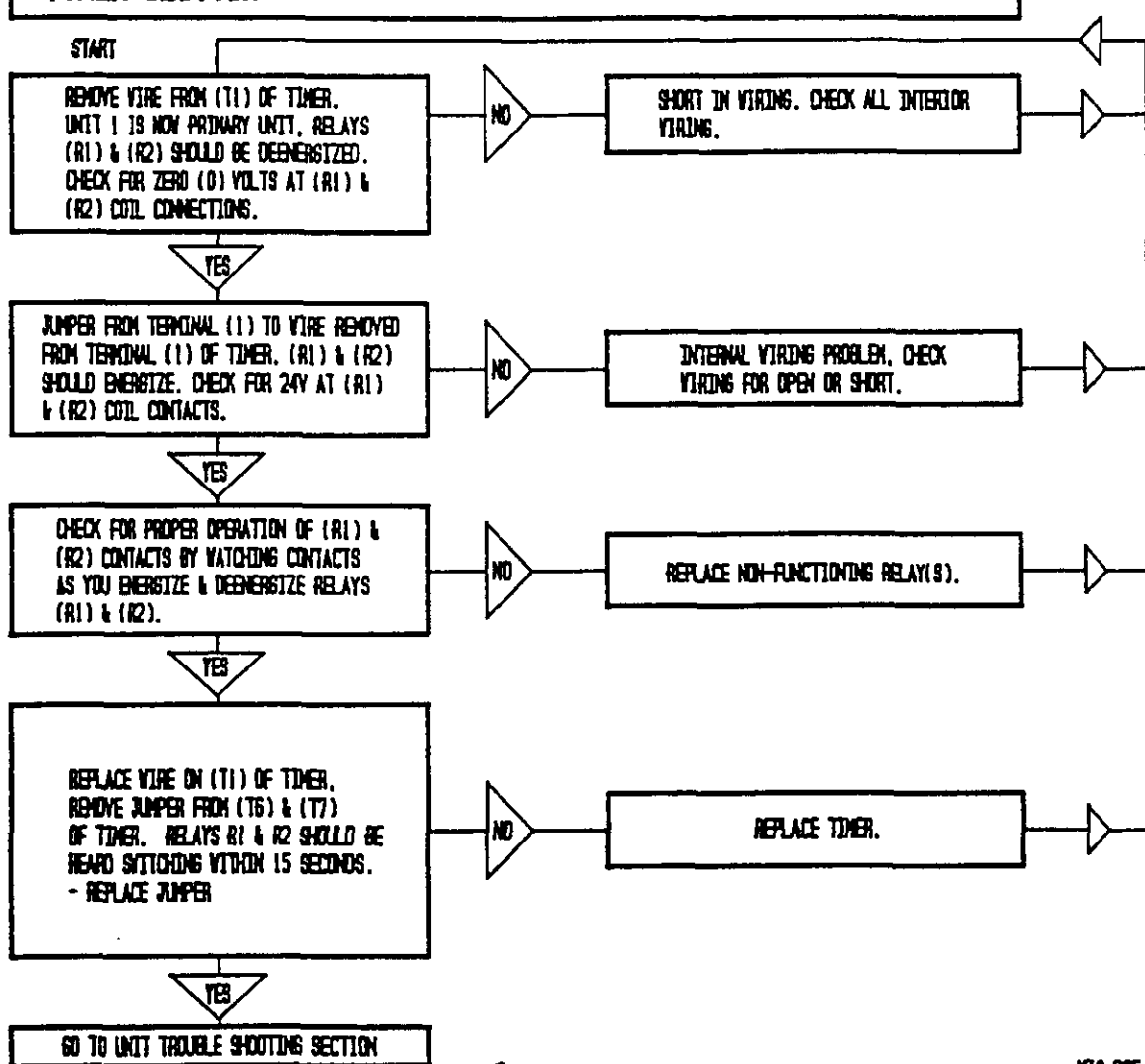

UNIT SECTION - TROUBLE SHOOTING UNITS #1 & #2

UNIT #1

YES

REMOVE WIRE FROM (T1) OF TIMER. UNIT 1 NOW PRIMARY UNIT. PERFORM NORMAL TROUBLE SHOOTING TECHNIQUES ON UNIT ONE ELECTRICAL & REFRIGERATION COMPONENTS. USE SEQUENCE OF OPERATION TO VERIFY PROPER OPERATION OF UNIT, THERMOSTAT, AND ECONOMIZER.

YES

NO

CHECK RELAYS R12, R11, AND R10 FOR PROPER OPERATION.
R10 SHOULD ENERGIZE ON A CALL FOR Y1.
R8 + R6 SHOULD ENERGIZE ON A CALL FOR Y2.
R9 SHOULD ENERGIZE ON A CALL FOR W1.
R7 SHOULD ENERGIZE ON A CALL FOR W2.

YES

NO

REPLACE MALFUNCTIONING RELAYS.

YES

UNIT #2

YES

REMOVE WIRE FROM (T1) OF TIMER & JUMPER TO TERMINAL 2 OF TIMER. UNIT 2 IS NOW PRIMARY UNIT. PERFORM NORMAL TROUBLE SHOOTING TECHNIQUES ON UNIT TWO ELECTRICAL & REFRIGERATION COMPONENTS. USE SEQUENCE OF OPERATIONS TO VERIFY PROPER OPERATION OF UNIT, THERMOSTAT, AND ECONOMIZER.

YES

NO

CHECK RELAYS R9, R8, AND R7 FOR PROPER OPERATION.
R8 SHOULD ENERGIZE ON A CALL FOR Y1.
R10 + R6 SHOULD ENERGIZE ON A CALL FOR Y2.
R7 SHOULD ENERGIZE ON A CALL FOR W1.
R9 SHOULD ENERGIZE ON A CALL FOR W2.

YES

NO

REPLACE MALFUNCTIONING RELAYS.

NO

GO TO ALARM TROUBLE SHOOTING SECTION

YES

POWER LOSS ALARM CIRCUIT TROUBLESHOOTING

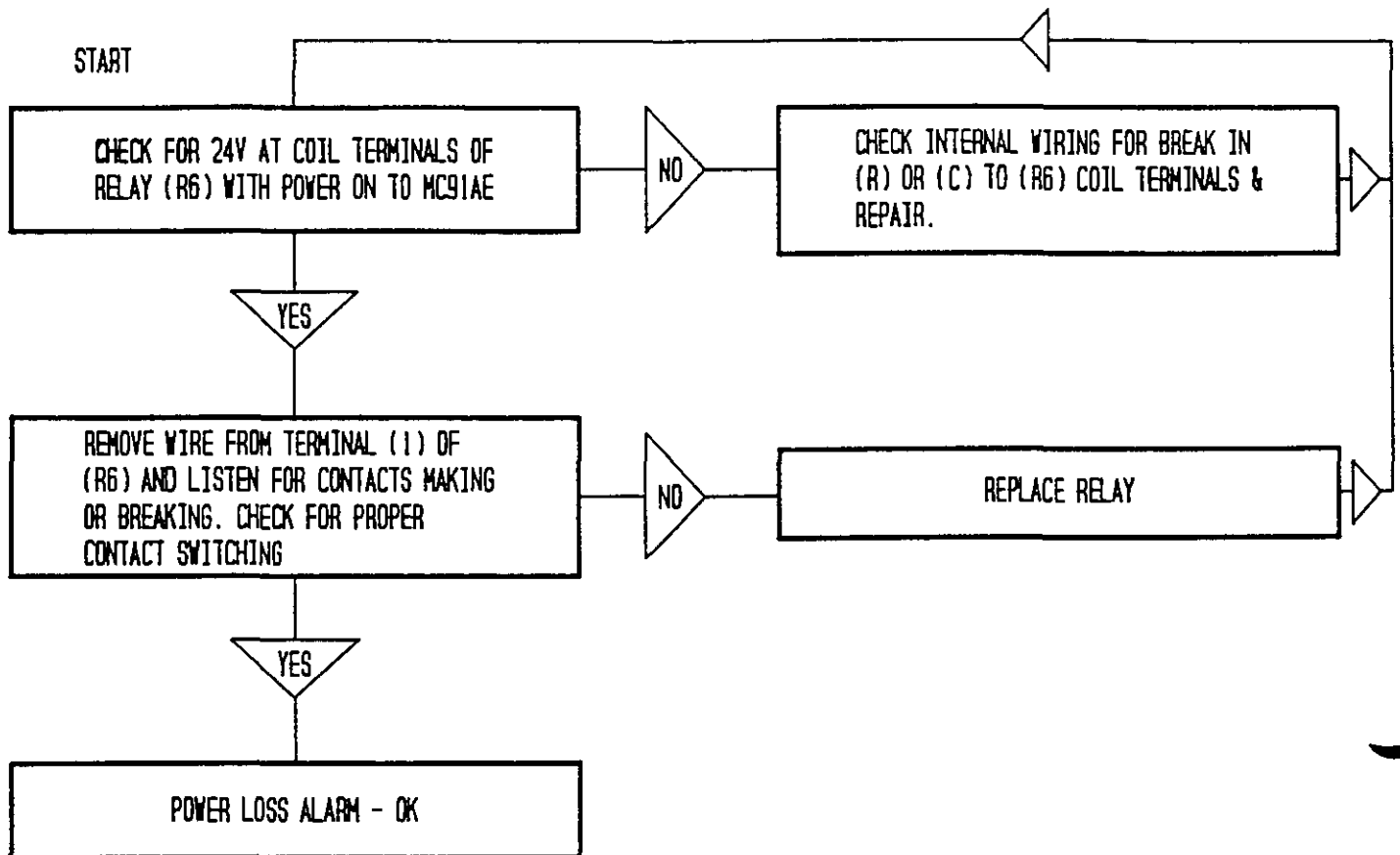

LOW TEMPERATURE ALARM - TROUBLE SHOOTING PROCEDURE

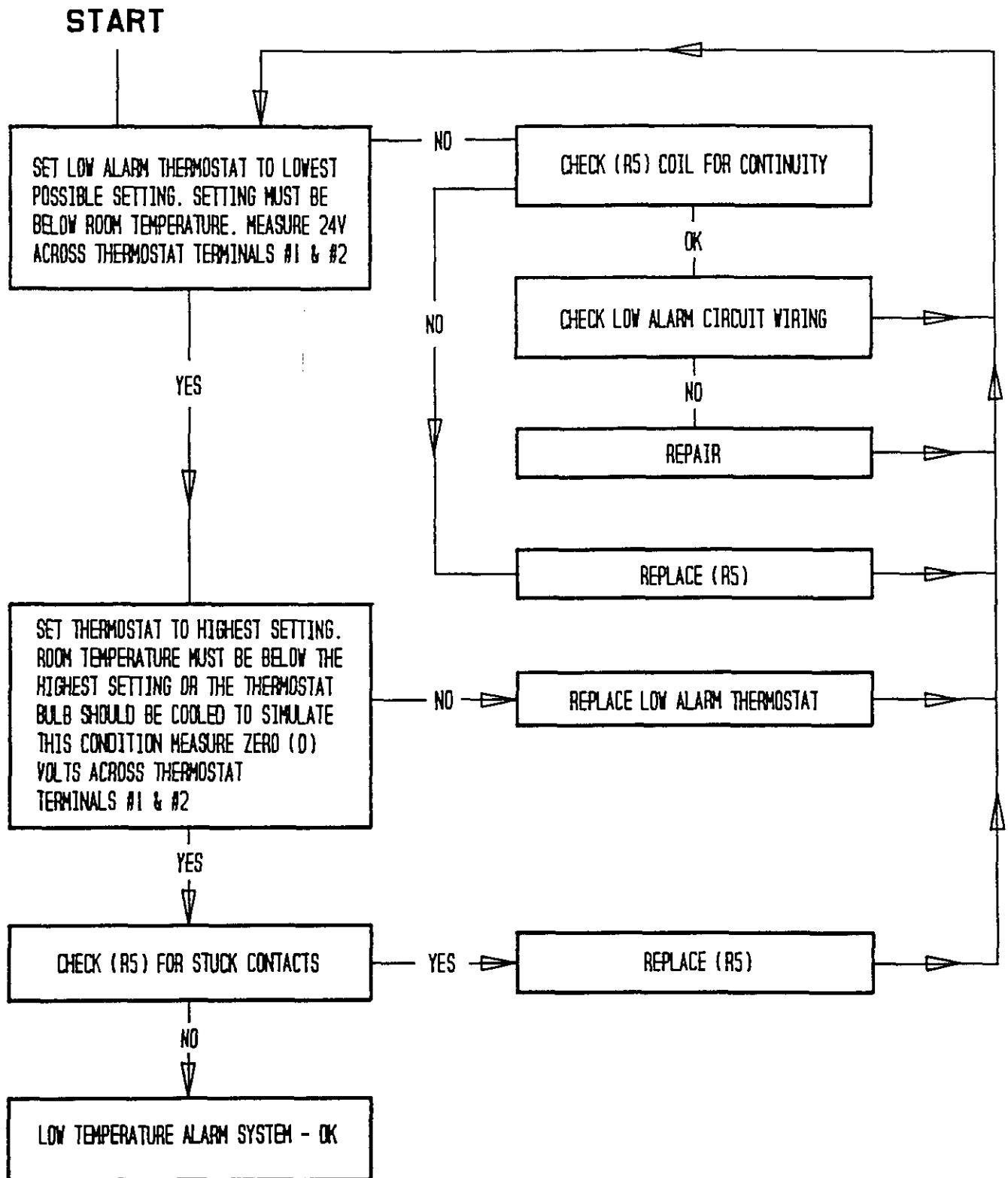

HIGH TEMPERATURE ALARM - TROUBLE SHOOTING PROCEDURE

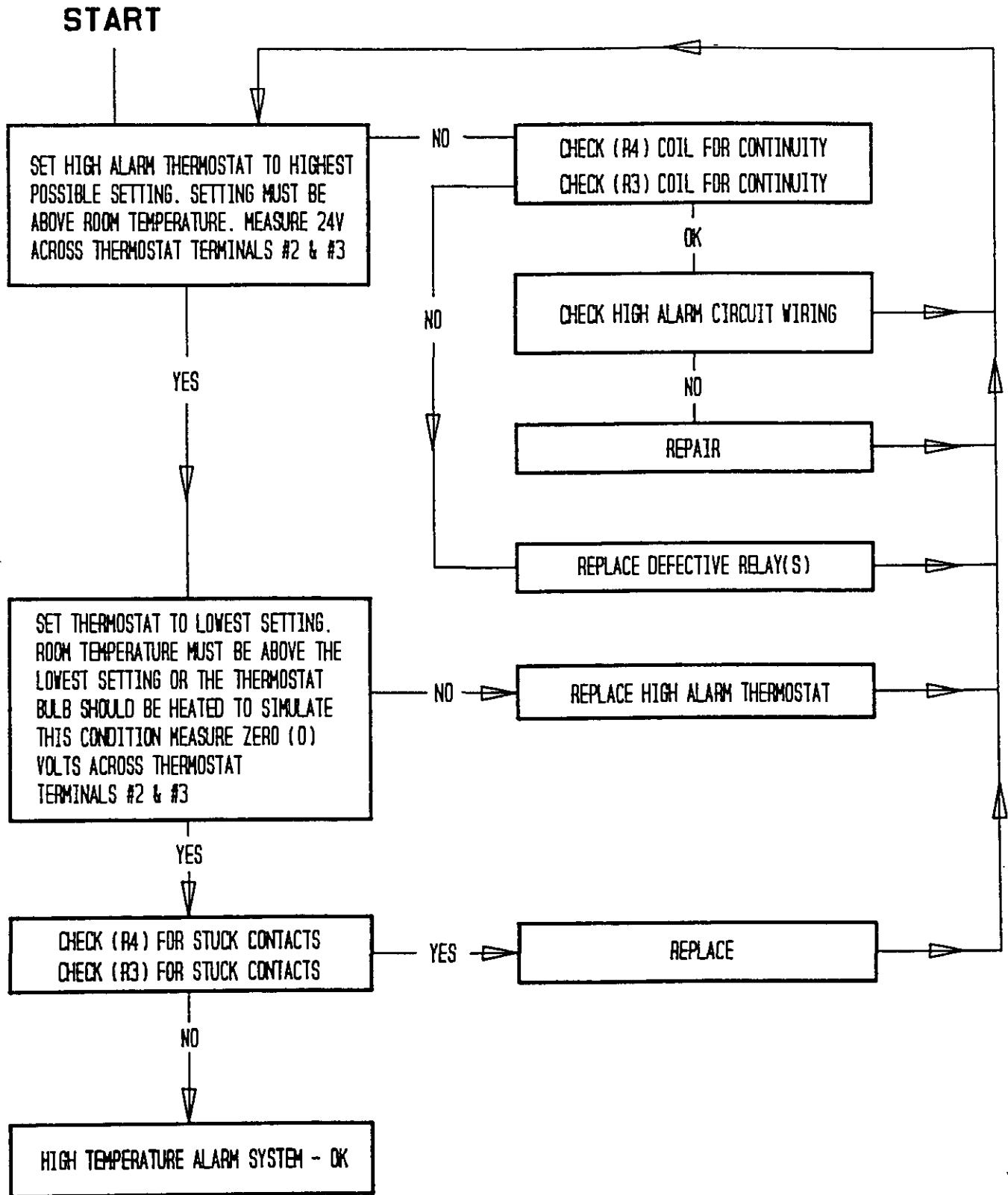

LOW VOLTAGE CONNECTIONS WITH ECONOMIZER

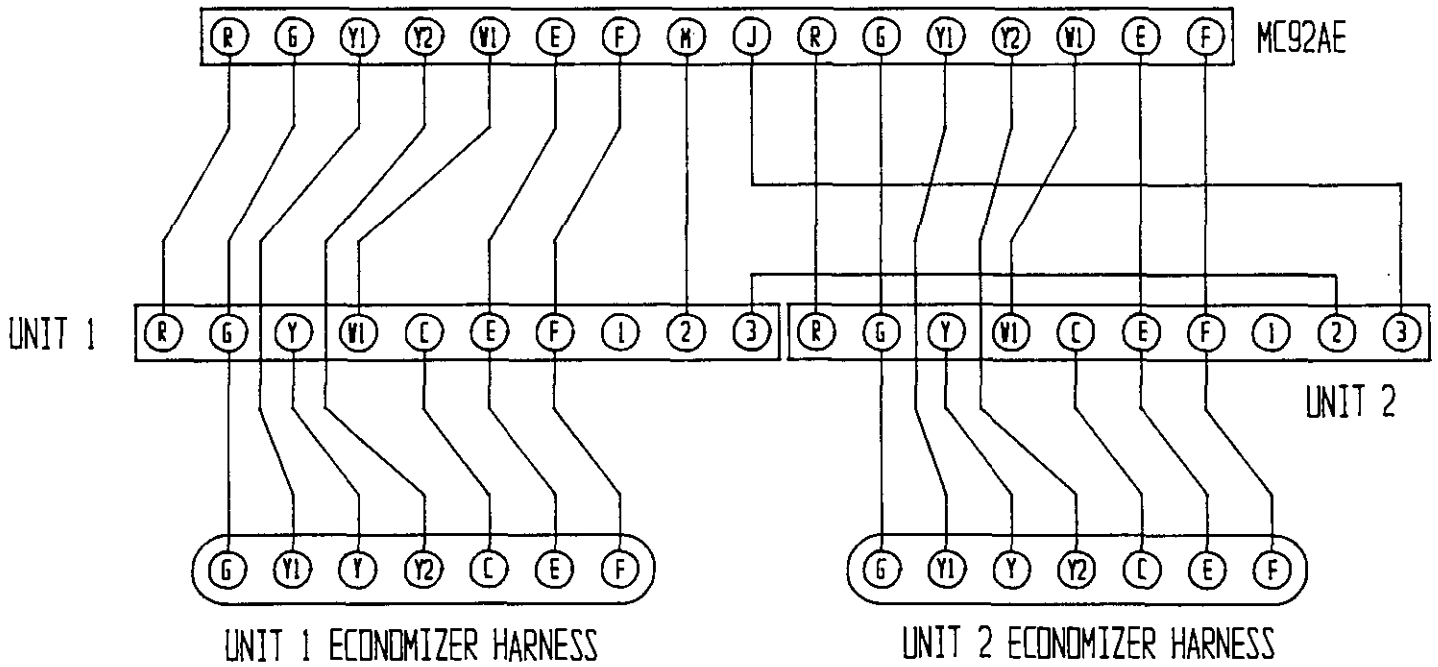
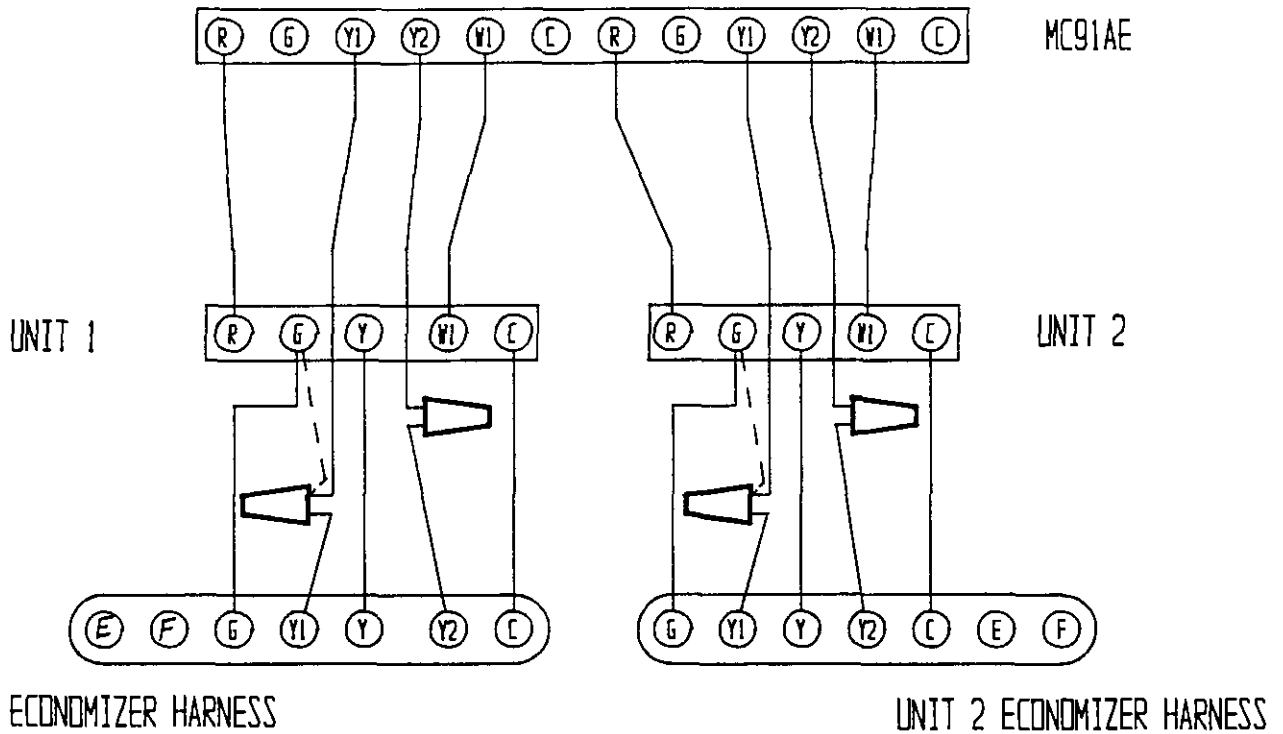

MC91AE LADDER DIAGRAM

L1 240 200 120 L2 120

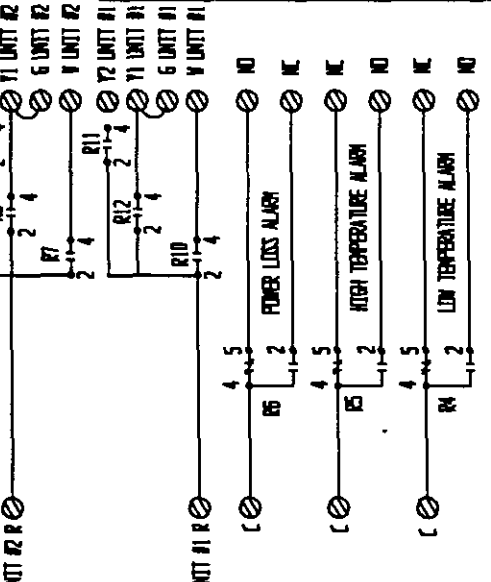
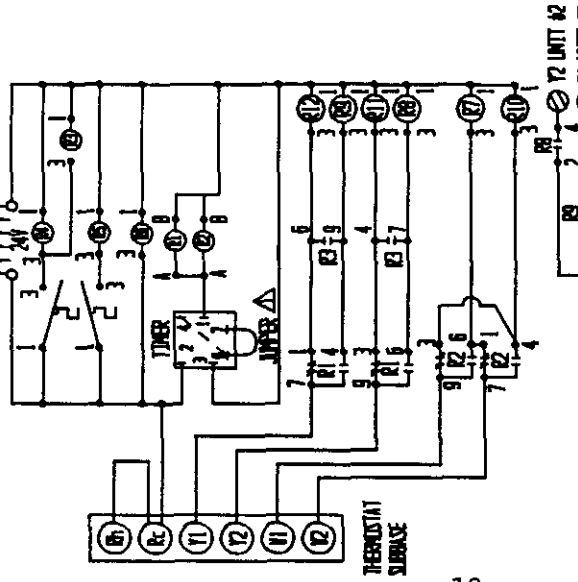

WIRE COLOR	COLOR CODE ABBREVIATION
BLACK	BK
BROWN	BR
RED	R
ORANGE	O
YELLOW	Y
GREEN	G
BLUE	B
VIOLET(PURPLE)	W(P)
GRAY(SLATE)	GT(S)
WHITE	W
TAN	T
PINK	PK
LAVENDER	L

MC91AE WIRING DIAGRAM

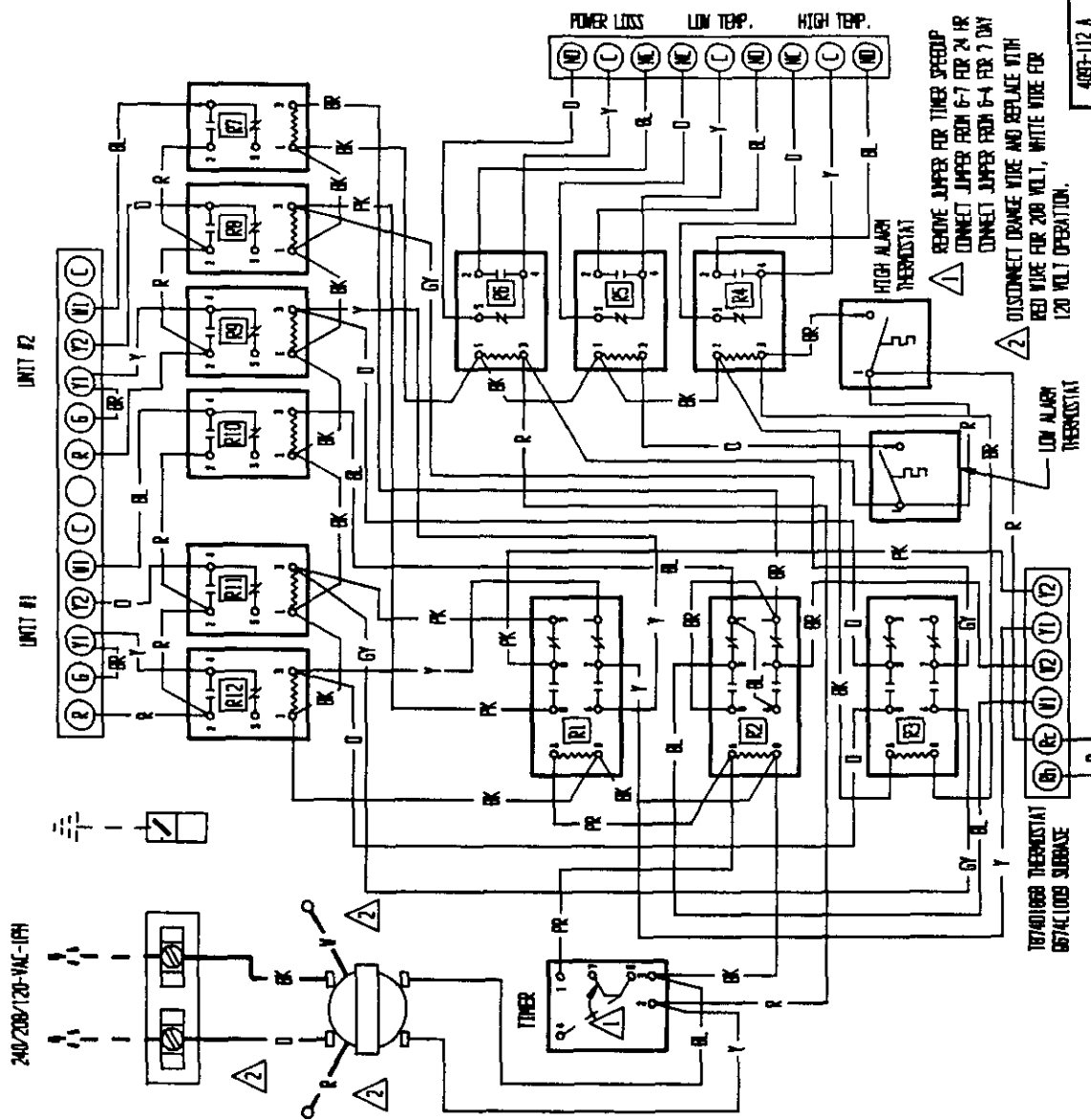

REMOVING JUMPER FOR TIMER SPEEDUP
CONNECT JUMPER FROM 6-7 FOR 24 HR
CONNECT JUMPER FROM 6-4 FOR 7 DAY

DISCONNECT ORANGE WIRE AND REPLACE WITH RED WIRE FOR 200 VOLT, WHITE WIRE FOR 120 VOLT OPERATION.

4893-112 A

MC92AE LADDER DIAGRAM

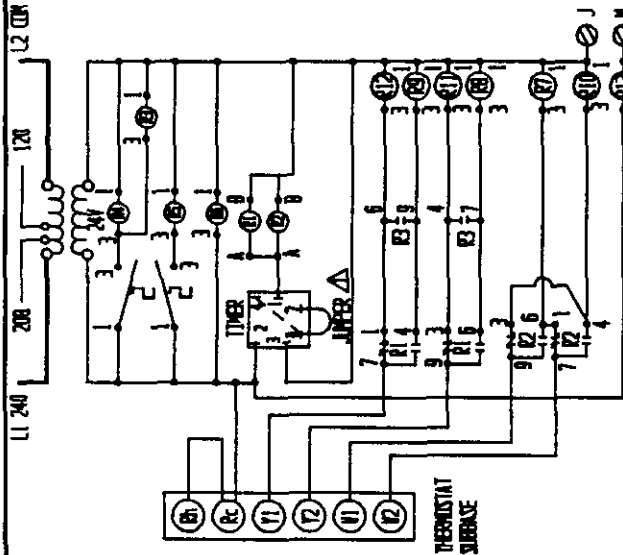

13

MC92AE WIRING DIAGRAM

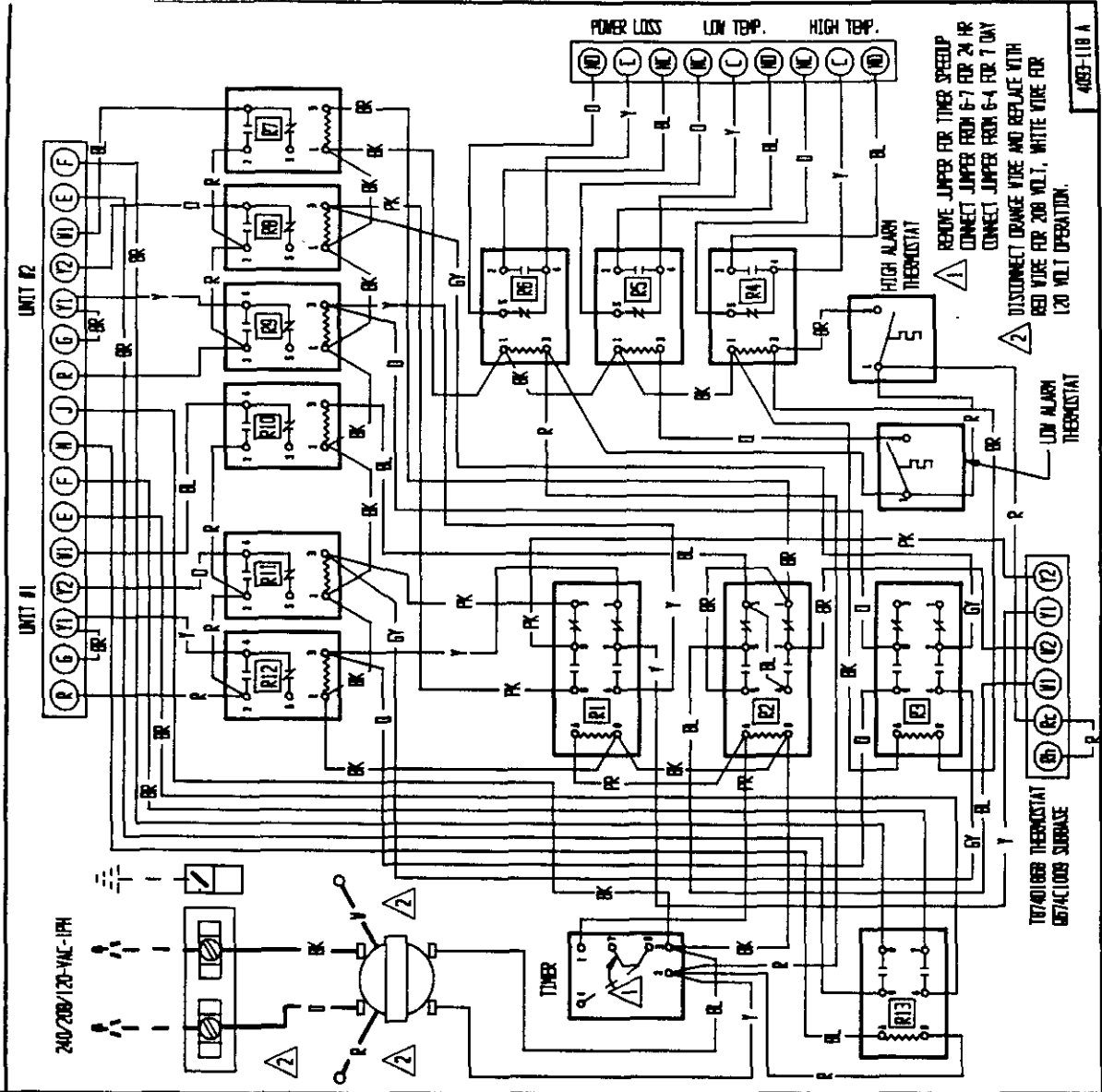

WIRE COLOR	COLOR ABBREVIATION
BLACK	BK
BROWN	BR
RED	R
BROWN	BR
ORANGE	O
YELLOW	Y
GREEN	G
BLUE	BL
VIOLET(PURPLE)	V(P)
GRAY(SLATE)	GY(S)
WHITE	W
TAN	T
PINK	PK
LAVENDER	L

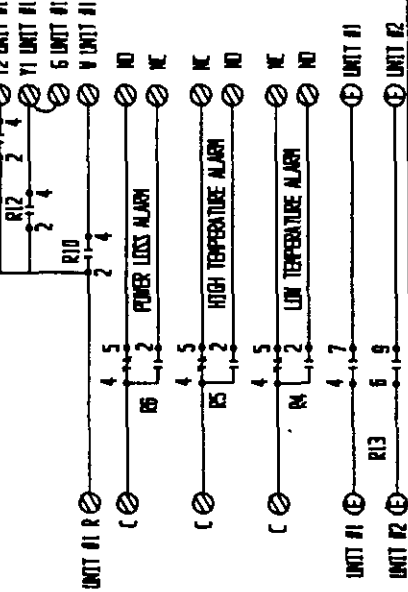

REMOVE JUMPER FOR TIMER SPEED
CONNECT JUMPER FROM 6-7 FOR 24 HR
CONNECT JUMPER FROM 6-4 FOR 7 DAY

DISCONNECT ORANGE WIRE AND REPLACE WITH
RED WIRE FOR 200 VOLT, WHITE WIRE FOR
120 VOLT OPERATION.

4087-118 A

HIGH VOLTAGE
FIELD CONNECTIONS



TRANSFORMER



UNIT 1

UNIT 2

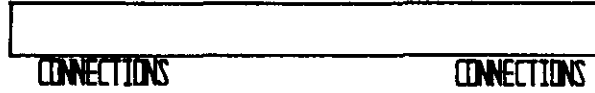

CONNECTIONS

CONNECTIONS



ALARM
CIRCUIT
CONNECTIONS

NOTE: OTHER TERMINAL LOCATIONS MARKED ON COMPONENTS.



- THERMOSTAT ————— PART # 8403-031
- SUBBASE ————— PART # 8404-013
- LOW ALARM THERMOSTAT — PART # 8408-021
- HIGH ALARM THERMOSTAT - PART # 8408-022
- RELAYS (R1, R2, R3, R13) - PART # 8201-0484
- RELAYS (R4 - R12) ——— PART # 8201-062
- TIMER ————— PART # 8612-014

FIGURE 3