

INSTALLATION INSTRUCTIONS

BC48B and BC60B

INDOOR BLOWER COIL UNIT

**FOR USE WITH
SPLIT HEAT PUMP AND
SPLIT AIR CONDITIONER SYSTEMS**

MANUAL 2100-179 REV. A
SUPERSEDES REV.
FILE VOL. 1, TAB 6

COPYRIGHT APRIL, 1991
BARD MANUFACTURING COMPANY
BRYAN, OHIO

TABLE OF CONTENTS

I.	APPLICATION AND LOCATION	7
	General	7
	Unpacking	7
	Application	7
	Ductwork	7
	Location and Clearances	8
	Mounting Position	8
	Expansion Device	9
	Caution When Using 5780 Series Couplings	10
	Interconnecting Tubing	10
	Condensate Drain	11
II.	WIRING	11
	Thermostat Low-Voltage Wiring	11
	Unit Operation	12
	Air Conditioning with Electric Heat	12
	Heat Pump with Electric Heat	12
	How To Set Adjustable Anticipator	13
	Additional Information For Electric Heat or Heat Pump Applications.	14
III.	SERVICE	14
	Two Speed Blower Motor	14
	Filter	15
	Wiring Diagram.	16
	Wall Thermostats	19

FIGURES AND TABLES

Figure 1	1
Figure 2	8
Figure 3	9
Figure 4	10
Figure 5	13
Figure 6	14

Table 1	2
Table 2	3
Table 3	3
Table 4	4
Table 5	4
Table 6	5
Table 7	6
Table 8	6
Table 9	7
Table 10	11
Table 11	12
Table 12	12
Table 13	12
Table 14	19

FIGURE 1

BC48B AND BC60B SERIES

**Upflow - Counterflow - Horizontal
2 Speed Direct Drive Motor
Slide-In Return Air Filter**

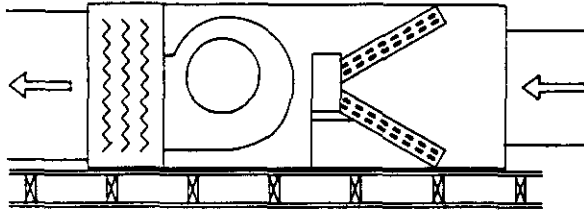

**HORIZONTAL (ATTIC OR CRAWL SPACE)
Requires Field Installed Horizontal
Drain Pan**

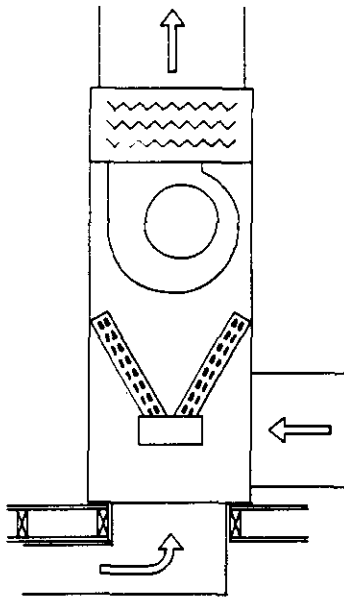
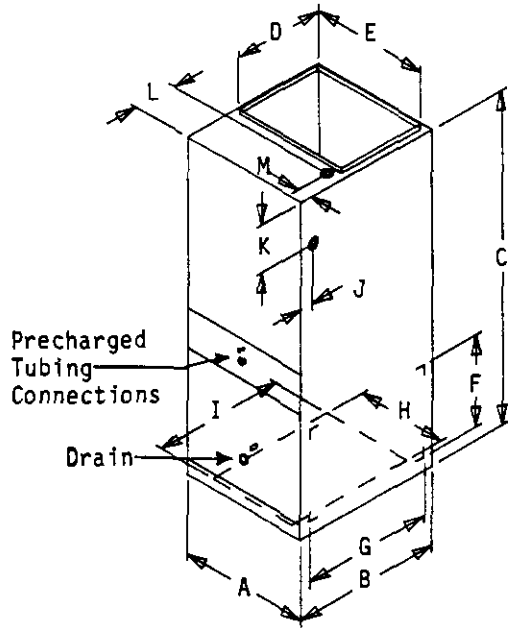

**UPFLOW (BOTTOM INLET OR
SIDE INLET)**

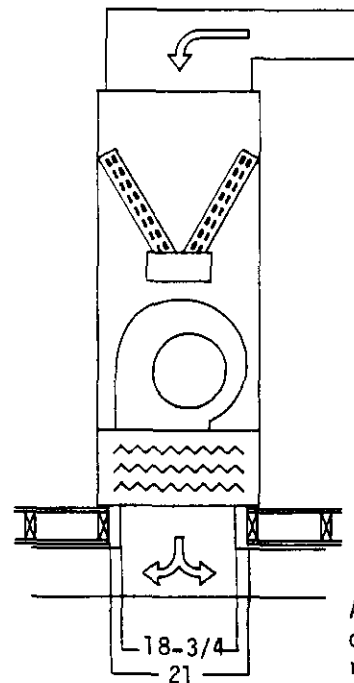

COUNTERFLOW

A 21 x 23 opening is required in the floor (mounting space).

WARNING: Failure to provide the one inch clearance for the first four feet between the supply duct and a combustible surface can result in fire.

Model	Cabinet Size			Supply Outlet		Side Return Air Opening		Bottom Return Air Opening		Electrical Opening Right Side		Electrical Opening Top	
	A	B	C	D	E	F	G	H	I	J	K	L	M
BC48B & BC60B	22	28-1/2	58-1/2	18-1/2	21	20	24	20	24	2	7	2	2-1/2

TABLE 1

Model	BC48B	BC48B
Electrical Rating--60HZ --50HZ	240/208-1 PH 240/220-1 PH	240/208-1 PH 240/220-1 PH
Operating Voltage Range	197-253	197-253
Fusing and Ampacity	See Electric Heat Table	
Blower and Motor	10x8 Direct	10x10 Direct
Motor--RPM/Speed	1075/2	1075/2
Motor--HP/AMPS	1/2 / 4.7	1/2 / 4.7
Evaporator Face Area Sq. Ft./Row/Fins Per Inch	8/3/10	8/4/14
Filter--Perm. or Throwaway	20x25x1 T	20x25x1 T
Refrigerant Cont./Orifice	.078	.092
Maximum Electric Heat	18KW	18KW

BLOWER COIL
MODEL

BC48B

TABLE 2
MAXIMUM E.S.P. OPERATION INFORMATION ELECTRIC HEAT ONLY

KW Installed	Upflow Position		Horizontal Position		Counterflow Position	
	Low Speed	High Speed	Low Speed	High Speed	Low Speed	High Speed
0KW	.80	.80	.80	.80	.80	.80
9KW 1PH	.80	.80	.80	.80	.80	.80
14KW 1PH	.80	.80	.80	.80	.80	.80
18KW 1PH	.80	.80	.80	.80	.80	.80
9KW 3PH	.80	.80	.80	.80	.80	.80
18KW 3PH	.80	.80	.80	.80	.80	.80

TABLE 3
MAXIMUM E.S.P. OPERATION INFORMATION HEAT PUMP HEATING WITH ELECTRIC HEAT

Compressor Section	KW Installed	Upflow Position		Horizontal Position		Counterflow Position	
		Low Speed	High Speed	Low Speed	High Speed	Low Speed	High Speed
42UHPOA 48UHPOA	0KW	.60	.60	.60	.60	.60	.60
42UHPOA 48UHPOA	9KW 1PH	.60	.60	.60	.60	.60	.60
42UHPOA 48UHPOA	14KW 1PH	.60	.60	.60	.60	.60	.60
42UHPOA 48UHPOA	18KW 1PH	.55	.60	.55	.55	.55	.60
42UHPOA 48UHPOA	9KW 3PH	.60	.60	.60	.60	.60	.60
42UHPOA 48UHPOA	18KW 3PH	.55	.55	.55	.55	.55	.55

BLOWER COIL
MODEL

BC60B

TABLE 4
MAXIMUM E.S.P. OPERATION INFORMATION ELECTRIC HEAT ONLY

KW Installed	Upflow Position		Horizontal Position		Counterflow Position	
	Low Speed	High Speed	Low Speed	High Speed	Low Speed	High Speed
0KW	.80	.80	.80	.80	.80	.80
9KW 1PH	.80	.80	.80	.80	.80	.80
14KW 1PH	.80	.80	.80	.80	.80	.80
18KW 1PH	.80	.80	.80	.80	.80	.80
9KW 3PH	.80	.80	.80	.80	.80	.80
18KW 3PH	.80	.80	.80	.80	.80	.80

TABLE 5
MAXIMUM E.S.P. OPERATION INFORMATION HEAT PUMP HEATING WITH ELECTRIC HEAT

Compressor Section	KW Installed	Upflow Position		Horizontal Position		Counterflow Position	
		Low Speed	High Speed	Low Speed	High Speed	Low Speed	High Speed
60UHPOA	0KW	.60	.60	.60	.60	.60	.60
60UHPOA	9KW 1PH	.60	.60	.60	.60	.60	.60
60UHPOA	14KW 1PH	.60	.60	.60	.60	.60	.60
60UHPOA	18KW 1PH	.60	.60	.60	.60	.60	.60
60UHPOA	9KW 3PH	.60	.60	.60	.60	.60	.60
60UHPOA	18KW 3PH	.60	.60	.60	.60	.60	.60

TABLE 6
 OPTIONAL FIELD-INSTALLED ELECTRIC HEATER TABLE

Heater Package Model No.	Heater Package Volts/Phase	Heater Amps, KW and Capacity @240 Volts			Heater Amps, KW and Capacity @208 Volts			(3) Minimum Circuit Ampacity	(3) Max. Fuse Size	(3) Maximum Circuit Breaker	(4) Field Wire Size
		AMPS	KW	BTU	AMPS	KW	BTU				
None								15	15	HACR Type 15	14
EH5BA-A09N,C	240/208-1	37.5	9	30690	32.5	6.75	23018	54	60	HACR Type 60	6
EH5BA-A14N,C	240/208-1	56.3	13.5	46035	48.7	10.13	34543	77	80	80	3
EH5BA-A18N,C	240/208-1	75	18	61380	64.9	13.5	46035	100	100	100	1
EH5BA-B09N	240/208-3	21.7	9	30690	18.7	6.75	23018	34	35	HACR Type 35	8
EH5BA-B18N	240/208-3	43.3	18	61380	37.5	13.5	46035	60	60	HACR Type 60	4

(3) Includes blower motor

(4) Suggested size based on use of 60 degree C wiring material for ampacities less than 100A.

NOTE: 9kw is the maximum electric heat approved for 50HZ applications.

INDOOR BLOWER COIL PERFORMANCE (DRY COIL) (3)

TABLE 7

Model	KW	Speed	Position	In H2O (1) (2)									Position	In H2O (2)								
				.00	.10	.20	.30	.40	.50	.60	.70	.80		.00	.10	.20	.30	.40	.50	.60	.70	.80
BC48B	0	Hi	Upflow/	1930	1850	1760	1690	1605	1520	1430	1305	1195	Horizontal	1872	1818	1770	1710	1640	1560	1480	1365	1265
BC48B	0	Low	Counterflow	1840	1780	1700	1640	1555	1480	1375	1255	1145	Horizontal	1775	1739	1690	1635	1570	1500	1375	1305	1195
BC48B	9	Hi	Upflow/	1900	1820	1730	1660	1575	1490	1400	1290	1180	Horizontal	1842	1788	1740	1680	1610	1530	1450	1350	1250
BC48B	9	Low	Counterflow	1810	1750	1670	1610	1525	1450	1360	1290	1130	Horizontal	1745	1709	1660	1605	1540	1470	1345	1290	1180
BC48B	14 (4)	Hi	Upflow/	1885	1805	1715	1645	1560	1475	1385	1275	1165	Horizontal	1827	1773	1725	1665	1595	1515	1435	1335	1235
BC48B	14 (4)	Low	Counterflow	1795	1735	1655	1595	1510	1435	1345	1225	1115	Horizontal	1730	1694	1645	1590	1525	1455	1330	1275	1165
BC48B	18 (4)	Hi	Upflow/	1870	1790	1700	1630	1545	1460	1370	1260	1150	Horizontal	1812	1758	1710	1650	1580	1500	1420	1320	1220
BC48B	18 (4)	Low	Counterflow	1780	1720	1640	1580	1495	1420	1300	1210	1100	Horizontal	1715	1679	1630	1575	1510	1440	1315	1260	1150

INDOOR BLOWER COIL PERFORMANCE (DRY COIL) (3)

TABLE 8

Model	KW	Speed	Position	In H2O (1) (2)									Position	In H2O (2)								
				.00	.10	.20	.30	.40	.50	.60	.70	.80		.00	.10	.20	.30	.40	.50	.60	.70	.80
BC60B	0	Hi	Upflow/	2100	2030	1960	1880	1790	1700	1605	1485	1365	Horizontal	2100	2030	1960	1900	1800	1720	1630	1520	1395
BC60B	0	Low	Counterflow	1960	1900	1835	1773	1710	1620	1530	1405	1295	Horizontal	1940	1885	1830	1760	1710	1630	1535	1425	1305
BC60B	9	Hi	Upflow/	2070	2000	1930	1815	1760	1670	1575	1470	1350	Horizontal	2070	2000	1930	1870	1770	1690	1600	1505	1380
BC60B	9	Low	Counterflow	1930	1870	1805	1743	1680	1590	1500	1390	1280	Horizontal	1910	1855	1800	1730	1680	1600	1505	1410	1290
BC60B	14 (4)	Hi	Upflow/	2055	1985	1915	1835	1745	1655	1560	1455	1335	Horizontal	2055	1985	1915	1855	1755	1675	1585	1490	1365
BC60B	14 (4)	Low	Counterflow	1915	1855	1790	1728	1665	1575	1485	1375	1265	Horizontal	1895	1840	1785	1715	1665	1585	1490	1395	1290
BC60B	18 (4)	Hi	Upflow/	2040	1970	1900	1820	1730	1640	1545	1440	1320	Horizontal	2040	1970	1900	1840	1740	1660	1570	1475	1350
BC60B	18 (4)	Low	Counterflow	1900	1840	1775	1713	1650	1560	1470	1360	1350	Horizontal	1880	1825	1770	1700	1650	1570	1475	1380	1260

- NOTE: (1) Values shown are standard for both bottom and side return air opening in upflow position only.
(2) Values shown are standard for bottom return air opening, side return air opening not applicable for counterflow or horizontal.
(3) Values shown are for 230V/60HZ operation. For 208V operation reduce air flow by 130 CFM. For 50HZ application reduce CFM's by 17%.
(4) Not approved for 50HZ application.

I. APPLICATION AND LOCATION

GENERAL

Units are shipped completely assembled and internally wired, requiring only duct connections, thermostat wiring and external 208-240 volt AC power supply.

The BC48B and BC60B blower coil units, with various KW electric heat options are suitable for use with the following air conditioner and heat pump outdoor sections. It can be used both as an air conditioning system with electric heat and as a heat pump with electric heat. Refer to sections titled, "AIR CONDITIONING WITH ELECTRIC HEAT and HEAT PUMP WITH ELECTRIC HEAT" for complete information.

TABLE 9
APPROVED COMBINATIONS

Air Conditioning		Heat Pump	
<u>Outdoor Section</u>	<u>Indoor Section</u>	<u>Outdoor Section</u>	<u>Indoor Section</u>
		42UHPQA	BC48B
		48UHPQA	BC48B
		60UHPQA	BC60B

UNPACKING

Upon receipt of equipment, carton should be checked for external signs of damage. If damage is found, request for inspection by carrier's agent should be made in writing immediately.

APPLICATION

Size of unit for a proposed installation should be based on heat loss calculation made according to methods of Air Conditioning Contractors of America. The air duct should be installed in accordance with the Standards of the National Fire Protection Association for the Installation of Air Conditioning and Ventilating Systems of Other Than Residence Type, NFPA No. 90A, and Residence Type Warm Air Heating and Air Conditioning System, NFPA No. 90B. Where local regulations are at a variance with instructions, installer should adhere to local codes.

DUCTWORK

Design the ductwork according to methods given by the Air Conditioning Contractors of America. When duct runs through unheated spaces, it should be insulated with a minimum of two inches of insulation. Use insulation with a vapor barrier on the outside of the insulation. Flexible joints should be used to connect the ductwork to the equipment in order to keep the noise transmission to a minimum.

LOCATION AND CLEARANCES

All access to the equipment is from one side, and at least 24 inches should be provided from this side for service access.

Unit casing is suitable for 0 inch clearance. The first four (4) feet of ductwork attached to the outlet (supply air) connections of the unit are to have a minimum of one inch clearance, with 0 inch clearance for any remaining ductwork.

FIGURE 2

A CFB45A combustible floor base is required for downflow installations to assure a 1" clearance from combustible materials to the outlet plenum (duct).

A 21 x 23 opening is required in the floor (mounting surface). See illustrations.

The CFB45A combustible floor base must be ordered separately. It is not included as part of the basic unit.

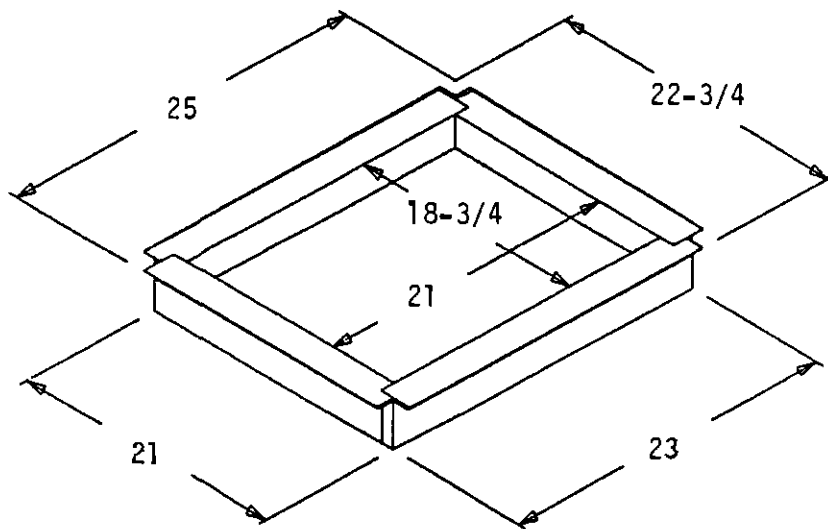

WARNING: Failure to provide the one inch clearance for the first four feet between the supply duct and a combustible surface can result in fire.

MOUNTING POSITIONS

The BC48B and BC60B can be installed in three positions with respect to airflow direction: Upflow, horizontal and downflow (see Figure 1). The general intent of these mounting positions is shown on the cover page of this installation manual. Capacity and efficiency ratings are certified in the vertical installation position. Capacity may be reduced slightly for other installation positions.

The unit is shipped with the coil installed for upflow position. It is secured in place by four screws, two on the top left support angles and two on the top right support angles. To convert to counterflow position, remove front access panel, remove the four screws securing coil pan assembly and remove coil.

Place cabinet in desired mounting position, and reinstall coil as shown on cover page. Make sure the coil is installed as shown with respect to blower.

IMPORTANT: The unit as received has coil installed for upflow position only. It must be rotated 180 degrees for downflow positions. See note under "Condensate Drain."

To convert to horizontal position, a field installed horizontal drain pan DPH-5BC is required. Instructions for installing the DPH-5BC are included with the drain pan.

EXPANSION DEVICE

The flow control orifice provides the function of the expansion device as well as distributes the refrigerant equally to all evaporator circuits. It features a "take apart" brass body which houses a removable piston-orifice assembly which meters the proper amount of refrigerant flow and serves as the expansion device. This orifice can be removed and replaced.

The orifice shipped installed with the Flow Control and coil is sized for the most popular evaporator to outdoor unit combination (size to size). Example: Outdoor unit 36UEPQA with BC60B indoor coil. For other combinations of indoor coil to outdoor unit application, the orifice in the flow control device **MUST** be changed to the size shown in the chart on Table 1. An additional proper sized orifice to be used with each outdoor unit is shipped packaged in the envelop with the installation instructions, with each outdoor unit. The installer should mark the size of the orifice installed on the rating plate of the indoor coil. The diameter of the orifice is stamped on the side of the brass orifice and plastic bag. Example: O63 indicates the orifice is .063" inside diameter.

CAUTION: Be sure there is no dirt introduced into the distributor--orifice assembly. Be sure and install the orifice with the bullet nose pointing in the proper direction as shown in Figure 4. Failure to do so will result in improper operation.

NOTE: If the orifice does not have to be changed, skip the instructions outlined further in Figure 4 and proceed to Figure 3 as applicable.

FIGURE 3
FLOW CONTROL ASSEMBLY
FIELD RESTRICTOR REPLACEMENT INSTRUCTIONS

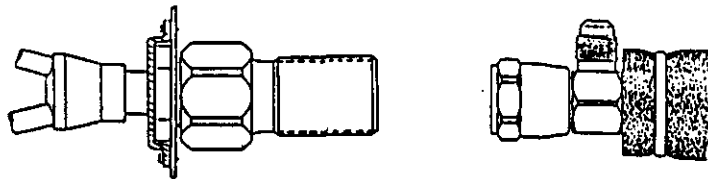

NOTE: DO NOT CONNECT LINE SETS! If restrictor needs to be changed, change out restrictor first.

STEP 1 Remove charge/pressure from indoor unit (if necessary--coupling style).

STEP 2 Disassembly Flow Control Assembly by turning body hex.

STEP 4 If existing restrictor has not dropped out of the body when disassembled, remove by using a pin or paper clip. Discard this original restrictor.

STEP 5 Thread assembly halves together by hand to insure proper mating of threads and tighten until bodies "bottom" or a definite resistance is felt.

STEP 6 Using a marker pen or ink pen, mark a line lengthwise from the union nut to the bulkhead. Then tighten an additional 1/6 turn (or 1 hex flat). The misalignment of the line will show the amount the assembly has been tightened. This final 1/6 turn is necessary to insure the formulation of the leakproof joint.

STEP 7 Complete piping and installation of unit per installation instructions. Figure 4 for detailed assembly instructions for coupling type coils.

CAUTION WHEN USING 5780 SERIES COUPLINGS

If coupling is every disconnected, the Flow Control Assembly connection may also be loosened. If this should occur, care must be taken to avoid loss of the restrictor. If loosened, repeat Step 5 above to insure the reformation of leakproof joint.

FIGURE 4
FLOW CONTROL FIELD ASSEMBLY PROCEDURES
PRE-CHARGE COUPLING LINE SET

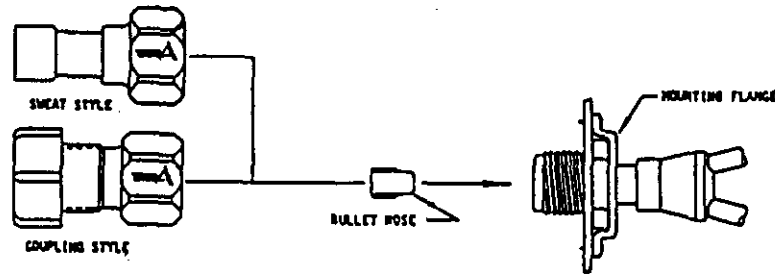

- STEP 8** Route the suction and liquid line between the indoor and outdoor unit. **CAUTION:** Do not connect the tubing to the outdoor unit yet.
- STEP 9** Remove protector caps and plugs.
- STEP 10** If necessary, carefully wipe coupling seats and threaded surfaces with a clean cloth to prevent the inclusion of dirt or any foreign material in the system.
- STEP 11** **LUBRICATE** male half diaphragm and synthetic rubber seal with refrigerant oil. Thread coupling halves together by hand to insure proper mating of threads. Use proper size wrenches (on line set coupling body hex and on union nut) and tighten until coupling bodies "bottom" or a definite resistance is felt.
- STEP 12** Using a marker or ink pen, mark a line lengthwise from the coupling union nut to the bulkhead. Then tighten an additional 1/4 turn; the misalignment of the line will show the amount the coupling has been tightened. This final 1/4 turn is necessary to insure the formation of leakproof joint. If a torque wrench is used, torque values recommends 10 to 12 foot pounds.
- STEP 13** Evacuate the lines and indoor unit before connecting to the outdoor unit. Refer to the installation instructions packed with the outdoor unit for details on setting the proper refrigerant charge. **NOTE:** The lines and indoor coil do not have to be evacuated if they were not opened to the atmosphere to change the orifice.

INTERCONNECTING TUBING

It is recommended that the interconnecting tubing be the CT series charged tubing sets. This is a precharged tubing set with an insulated suction line. Both suction and liquid line are equipped with the correct quick connect fittings for proper match-up to the indoor and outdoor sections. The CT series is available in standard tubing lengths of 15, 25, 35 and 45 feet.

NOTE: Applicable installation codes may limit installation to single story structure only if return air duct is not used.

CONDENSATE DRAIN

Determine where the drain line will run. This drain line contains cold water and must be insulated to avoid drops of water from dropping on ceiling, etc. A trap must be installed in the primary drain line below the bottom of the drain pan.

For horizontal installations with auxiliary drain pan, a separate drain line should be run from the auxiliary drain pan and terminated where the homeowner can see it. Be certain to show the homeowner the location of the drain line and to explain its purpose. In the event of overflow of primary drain, water will collect in auxiliary pan and run out through the auxiliary drain line.

It is not recommended that any condensate drain lines be connected to sewer main. Drain lines must be installed in accordance with local codes.

When installed horizontal in an attic installation, a platform should be made for the unit to sit on. This platform can be made from 3/4 inch plywood or boards. An auxiliary drain pan should always be used when equipment is installed over a finished living area, to provide protection from water damage in case of plugging of the primary drain line from the unit condensate collection pan.

Secure 4 pieces of cork or live rubber, 4" x 4", of sufficient thickness to allow primary drain to clear edge of auxiliary drain pan, under each corner of the unit.

NOTE: There are two 3/8" copper tubes brazed through the coil drain pan approximately 2 inches from the 3/4 inch main drain pipe coupling. These are overflow drains to control the point at which water would exit the drain pan in the event the primary drain becomes plugged. When ever the coil assembly is removed and reinstalled, make sure the 3/8" drain overflow tubes extend slightly beyond the coil door when in place.

II. WIRING

THERMOSTAT LOW-VOLTAGE WIRING

A 24V terminal block is mounted on the inside of the unit. There is also a 24V terminal block located in the outdoor section of remote heat pumps and two tagged 24V wires in the outdoor section of remote air conditioners. Wire sizing is determined from the table below for 24V control circuit wiring.

TABLE 10

<u>Transformer VA</u>	<u>FLA @ 240V</u>	<u>Maximum Distance in Feet (1)</u>
55	2.3	20 gauge - 45 18 gauge - 60 16 gauge - 100 14 gauge - 160 12 gauge - 250

(1) For split systems, this is the maximum distance between the indoor section and outdoor section, and between the indoor section and thermostat each could be up to 90 feet for 18 gauge and 65 feet for 20 gauge on 40VA transformer. With a 65VA transformer and 20 gauge wire, the maximum distance is 40 feet.

Specific control circuit wiring diagrams for the various applications are referenced in the sections titled "AIR CONDITIONING WITH ELECTRIC HEAT and HEAT PUMP WITH ELECTRIC HEAT." These diagrams detail the recommended controls and wiring to allow the best possible operation of the different types of systems with respect to energy conservation while still maintaining close comfort levels for the occupant.

UNIT OPERATION

The controls in the BC48B and BC60B provide for manual/auto fan control in addition to the staging of the installed electric heat. Staging is accomplished in basic 9KW increments, that is, each two (2) heating elements are controlled by one heat relay.

TABLE 11
HEATER ELEMENT STAGING

Heater KW	Stages
5, 9	1
14, 18	2

Heater stage designations are as follows on the 24V terminal strip:

W2 1st stage
W3 2nd stage
DH 3rd stage

AIR CONDITIONING WITH ELECTRIC HEAT

Typical situations would be to utilize a 1-stage cool, 1-stage heat wall thermostat for 5 and 9KW applications, and a 1-stage cool/2-stage heat thermostat for 14 and 18KW applications. Listed below are the appropriate control circuit connection diagrams based upon KW rating and also the number of field installed outdoor thermostats required for each application.

TABLE 12

KW Rating	Connection Diagram	Quantity Outdoor Thermostats
0	4091-300	0
5, 9	4091-301	0
14, 18	4091-303	0

HEAT PUMP WITH ELECTRIC HEAT

The system and its safety controls are designed in such a manner that the heat pump and up to 18KW of the resistance strip heaters can operate at the same time, being brought on in stages.

Listed below are the appropriate control circuit connection diagrams based on KW rating, and also the number of field installed outdoor thermostats recommended for each application.

TABLE 13

KW Rating	Connection Diagram	Quantity Outdoor Thermostats
0	4091-400 or 4091-805	0
5, 9	4091-401 or 4091-806	1
14, 18	4091-403 or 4091-807	1

In geographical areas where compressor cut-off would not be required because winter temperatures below 10 degrees F are never experienced, disregard the compressor cut-off wiring shown on the control circuit diagram.

HOW TO SET AN ADJUSTABLE ANTICIPATOR

The primary purpose of the adjustable anticipator thermostat is to provide a single thermostat to match almost any type of primary control in the field today.

Figure 5

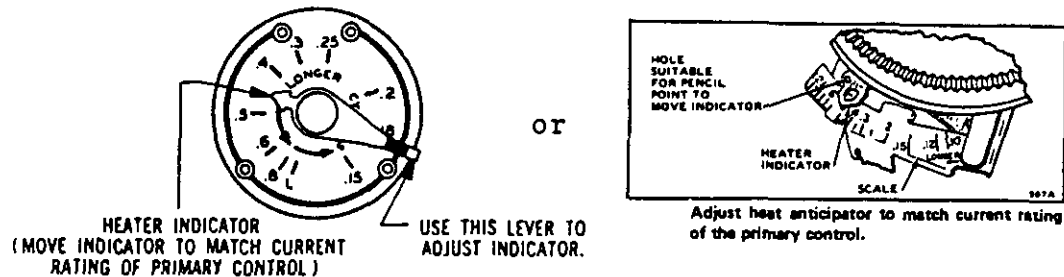

The adjustable heat anticipator has a slide wire adjustment with the pointer scale marked in tenths of an ampere. This is used to set the anticipator to agree with the control amp draw of the control system in use.

If the primary control nameplate has no rating or if further adjustment is necessary, use the following procedure to determine the current draw of each stage.

The current draw of each heating stage must be measured with the thermostat removed and the power on.

1. Connect an AC ammeter of appropriate range between the heating terminals of the subbase.

Stage 1 -- between W1 and RH or R

Stage 2 -- between W2 and RH or R

2. Move the system switch to HEAT or AUTO.
3. After one minute, read the ammeter and record the reading.
4. After mounting the thermostat, set the adjustable heat anticipator(s) to match the respective reading(s) measured in Step 3.

If you want to change the cycle of the heating system, you can make a simple adjustment on the anticipator to do this.

Additional adjustment, if necessary, may be made as follows:

Heater cycles too short--set adjustable heater to a slightly higher dial setting (1/2 division).

Heater cycles too long--set adjustable heater to a slightly lower dial setting (1/2 division).

Occasionally you may find a system where longer or shorter cycles of the primary control are desirable. If the primary control draws .45 amps and you want a longer cycle, set the anticipator to .5 or .6 amps. This puts less resistance in the circuit. With less resistance, but the same current (from the primary control), you will generate less "false" heat and get a longer cycle of the primary control.

If a setting of .45 amps on the adjustable anticipator gives a cycle that is longer than desired, reset the indicator to .3 or .25 amps. This will put more resistance in the circuit and thus generate more "false" heat for shorter cycles.

ADDITIONAL INFORMATION FOR ELECTRIC HEAT OR HEAT PUMP APPLICATIONS

Adjust heat anticipator to match current rating of heating relay for W1 (and W2 if 2 stage). Move indicator on the scale to correspond with this current rating.

If the current rating is not given, proceed as follows:

1. Wrap exactly 10 loops of thermostat wire (W1) around the prongs of an Amprobe.
2. Let the heating system operate for one minute before reading the W1 or W2 current draw.
3. Divide the reading obtained in Step 2 by 10.
4. Use the value calculated in Step 3 to set the heat.
5. Repeat the procedure for (W2) if 2 stage heat anticipator.

NOTE: Cooling anticipators on all thermostats are fixed and do not require setting.

FIGURE 6

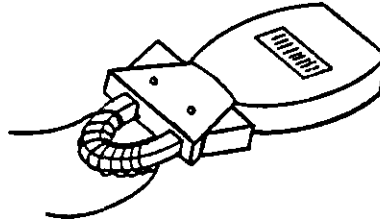

Example: $\frac{6.0 \text{ Amp}}{10 \text{ loops}} = .6\text{A}$

III. SERVICE

TWO SPEED BLOWER MOTOR

The BC48B and BC60B both have a two speed, 1/2 hp blower motor.

Motor lead wire identification is as follows:

Common	Yellow
High	Black
Low	Red
Capacitor	Brown

Both models are shipped wired on high speed. The unused red (low speed) lead wire is taped off. If low speed operation is desired, remove and tape black wire from terminal com. on blower relay and connect red wire to terminal com. Refer to wiring diagrams for electrical circuitry and to airflow charts for capabilities and limitations on blower speeds, static pressures and air delivery versus installed KW heaters.

FILTER

These units come equipped with a 20" x 25" x 1" thick disposable fiberglass filter and must not be operated without a filter in place. Filter access is gained by removing an angle piece located at the bottom of the main unit cabinet (as viewed in upflow position).

The filter should be replaced periodically throughout the year, as these are year-round heat-cool systems. Special attention should be given to filter cleanliness on any new installation, as airborne dust and debris from recent construction can easily plug a filter in a matter of days.

Dirty filters are the most prevalent and most easily corrected problem to be encountered in any forced air heating and/or cooling system.

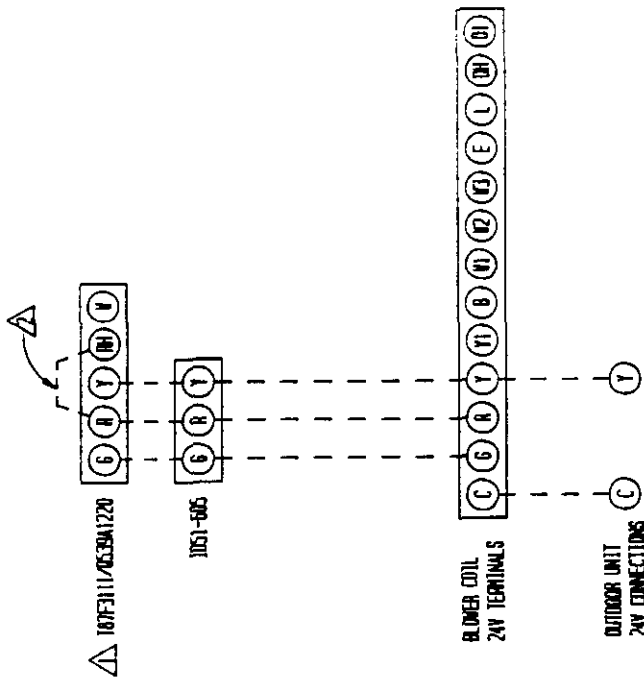

△ SET ADJUST HEAT ANTICIPATOR (SEE BLOWER COIL INSTRUCTIONS).

△ INSTALL JUMPER R-H

AIR CONDITIONER V/OKV BLOWER COIL

FACTORY WIRING	FIELD WIRING
LOW VOLTAGE	---
HIGH VOLTAGE	---

4091-300

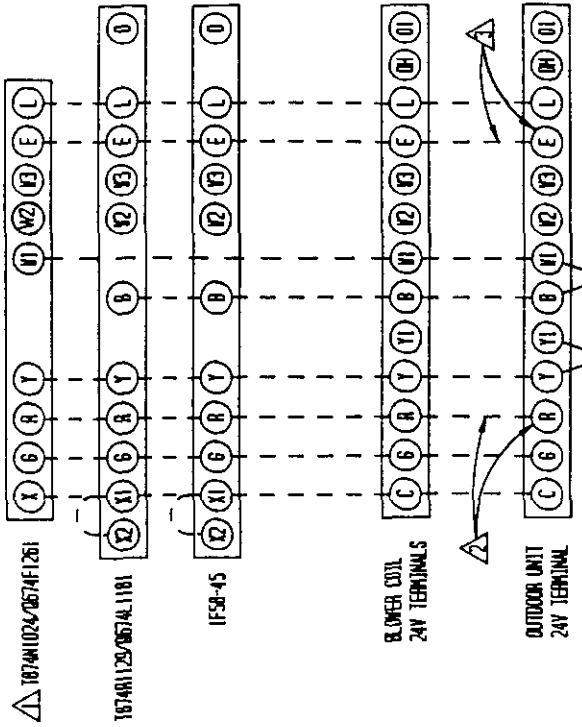

HEATPUMP V/OKV BLOWER COIL

△ SET ADJUST HEAT ANTICIPATOR (SEE BLOWER COIL INSTRUCTIONS).

△ 18-38PPU UNITS DO NOT HAVE (B) TERMINAL AND IT IS NOT REQUIRED TO RUN AN (B) WIRE TO THESE MODELS.

△ 42-60PPU UNITS DO NOT HAVE (E) TERMINAL AND IT IS NOT REQUIRED TO RUN AN (E) WIRE TO THESE MODELS.

FACTORY WIRING	FIELD WIRING
LOW VOLTAGE	---
HIGH VOLTAGE	---

4091-100A

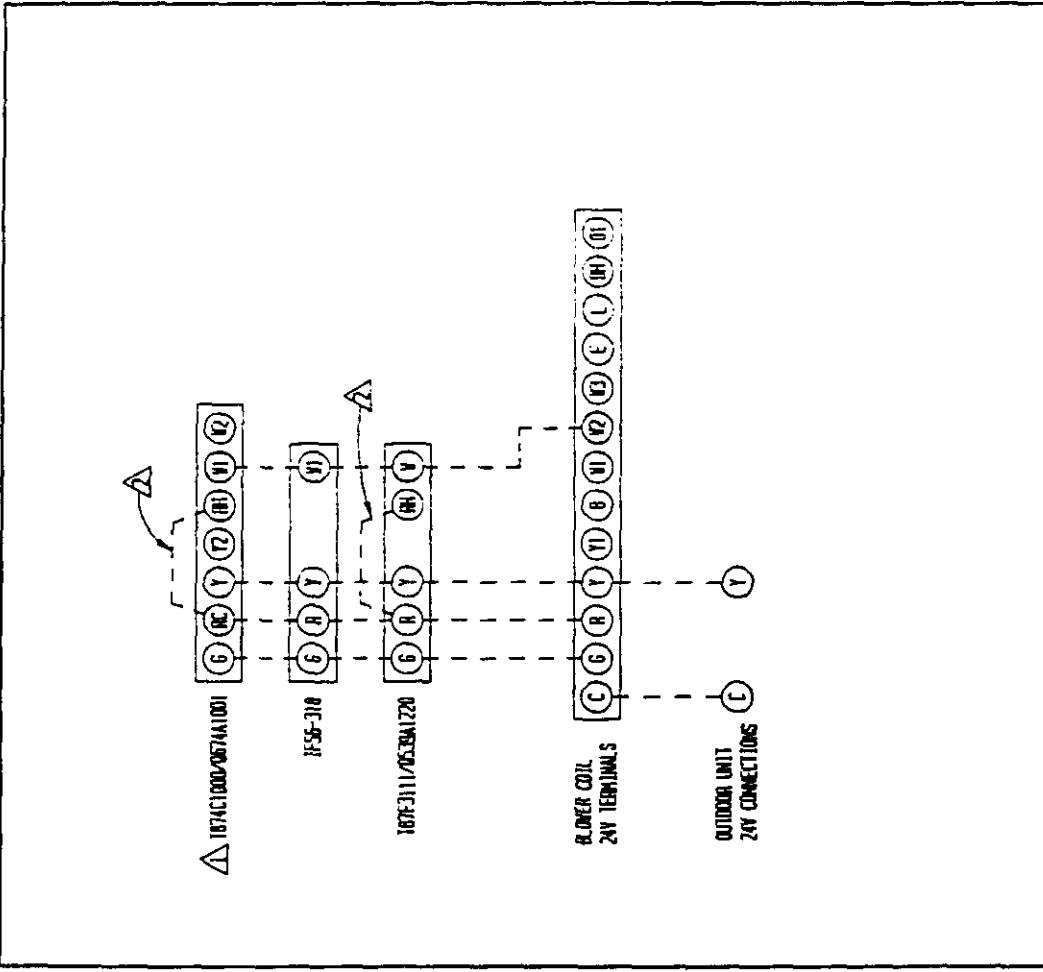

4991-301

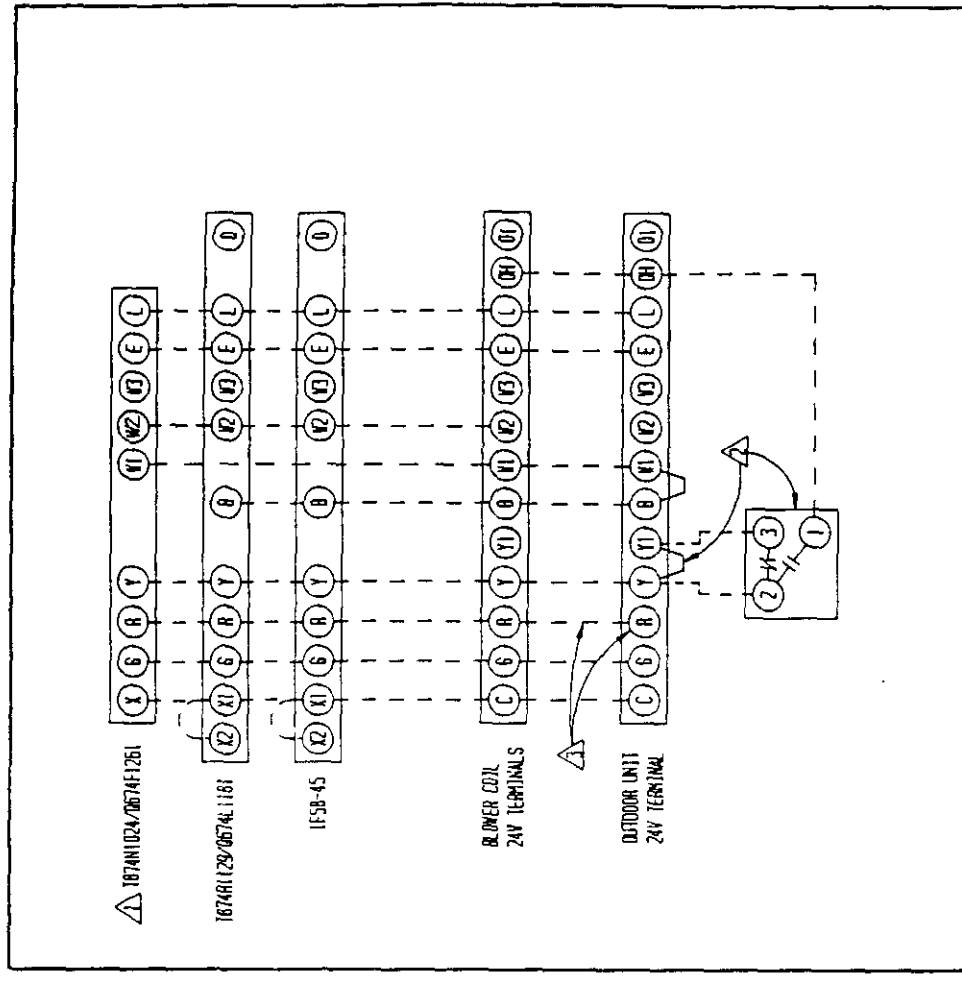

4991-401 B

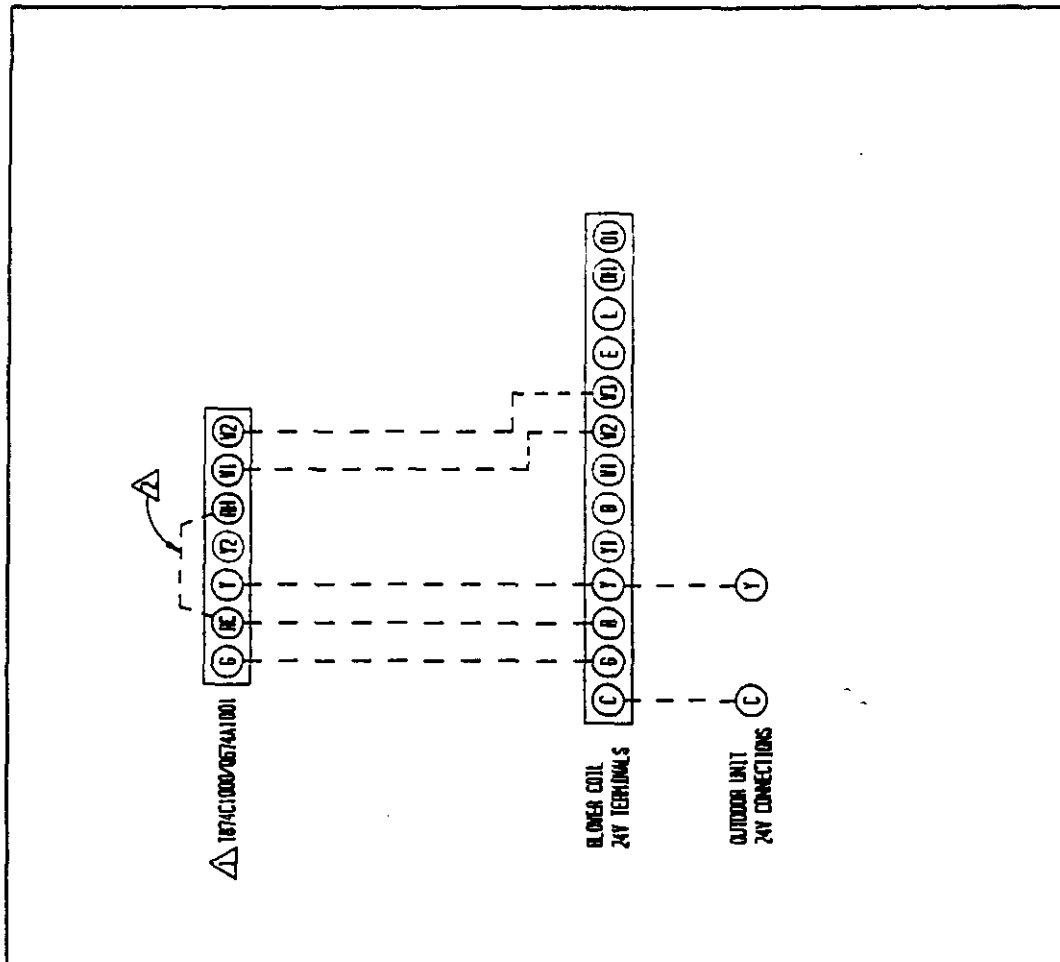

- △ SET ADJUST HEAT ANTICIPATION (SEE BLOWER COIL INSTRUCTIONS).
- △ INITIAL JUMPER RE-IN

AIR CONDITIONER 1/14 TO 20KV BLOWER COIL EXCEPT FOR B080P-A1S & B080A MODEL'S

FACTORY WIRING	FIELD WIRING
LOW VOLTAGE	---
HIGH VOLTAGE	---

4091-303

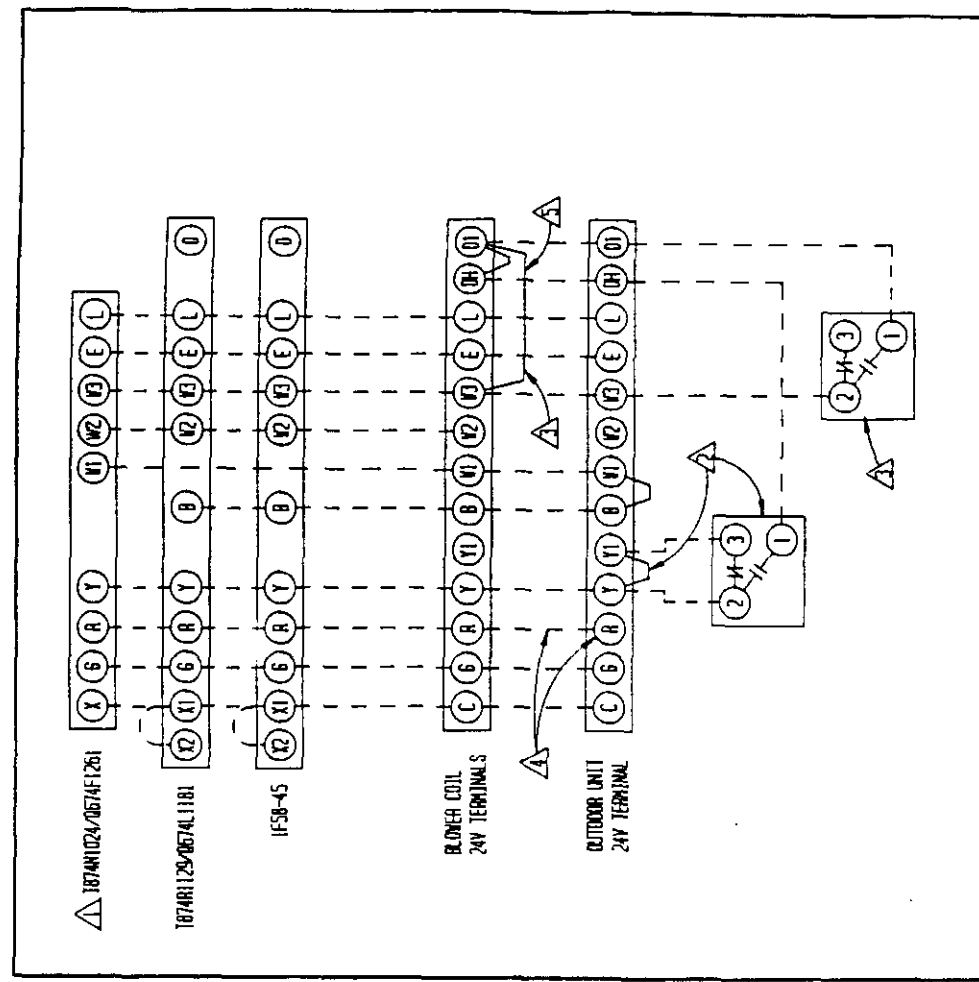

- △ SET ADJUST HEAT ANTICIPATION (SEE BLOWER COIL INSTRUCTIONS).
- △ WHEN OUTDOOR THERMOSTAT (USED AS COMPRESSOR CUTOFF) IS INSTALLED, REMOVE JUMPER Y-Y1.
- △ IF OUTDOOR THERMOSTAT IS USED TO STAGE HEAT, REMOVE JUMPER Y3-O1.
- △ 18-38HP UNITS DO NOT HAVE ② TERMINAL AND IT IS NOT REQUIRED TO RUN AN ② WIRE TO THESE MODELS.
- △ FOR DOWNFLOW APPLICATIONS, REMOVE JUMPER Y3-O1 ON B0356 & B0358 MODELS ONLY.

4091-403 B

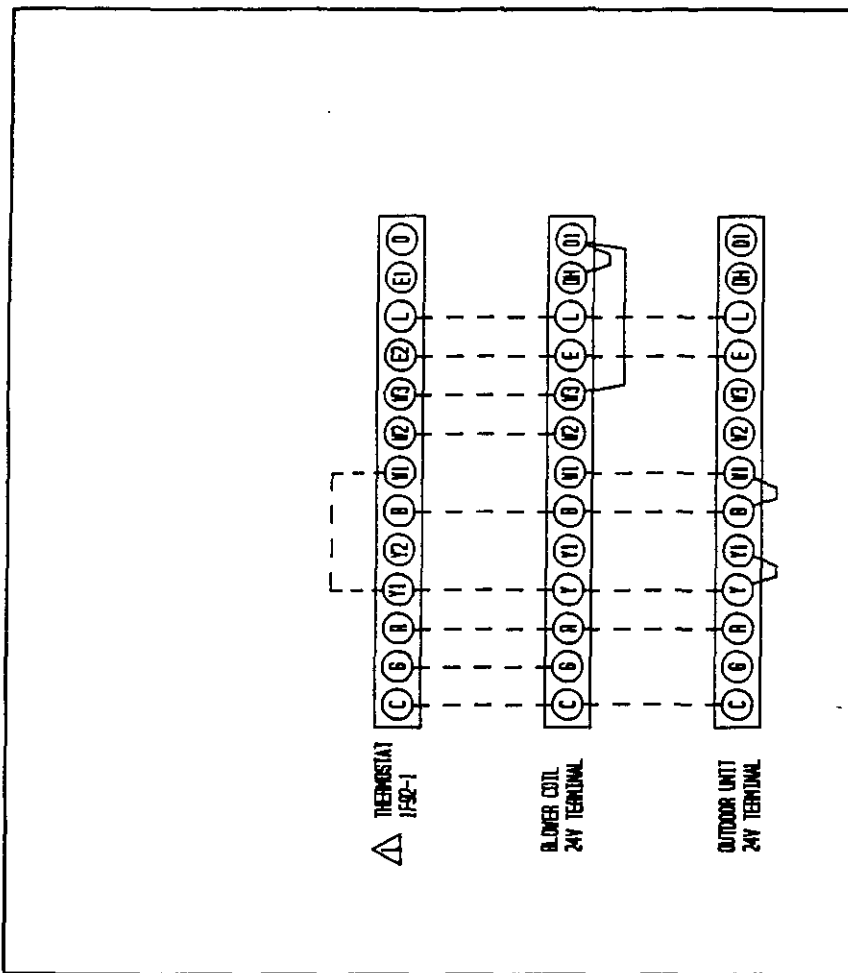

▲ THERMOSTAT 1F92-1
 BLOWER COIL 24V TERMINAL
 OUTDOOR UNIT 24V TERMINAL

▲ OPTION SWITCH SETTING
 SWITCH #1 'OFF'
 SWITCH #2 'OFF'
 SWITCH #3 'OFF'
 SWITCH #4 SEE THERMOSTAT INSTALLATION INSTRUCTIONS

ON 1 2 3 4

FACTORY WIRING _____
 FIELD WIRING _____

LOW VOLTAGE _____
 HIGH VOLTAGE _____

HEATPUMP V/OVR BLOWER COIL

4081-805

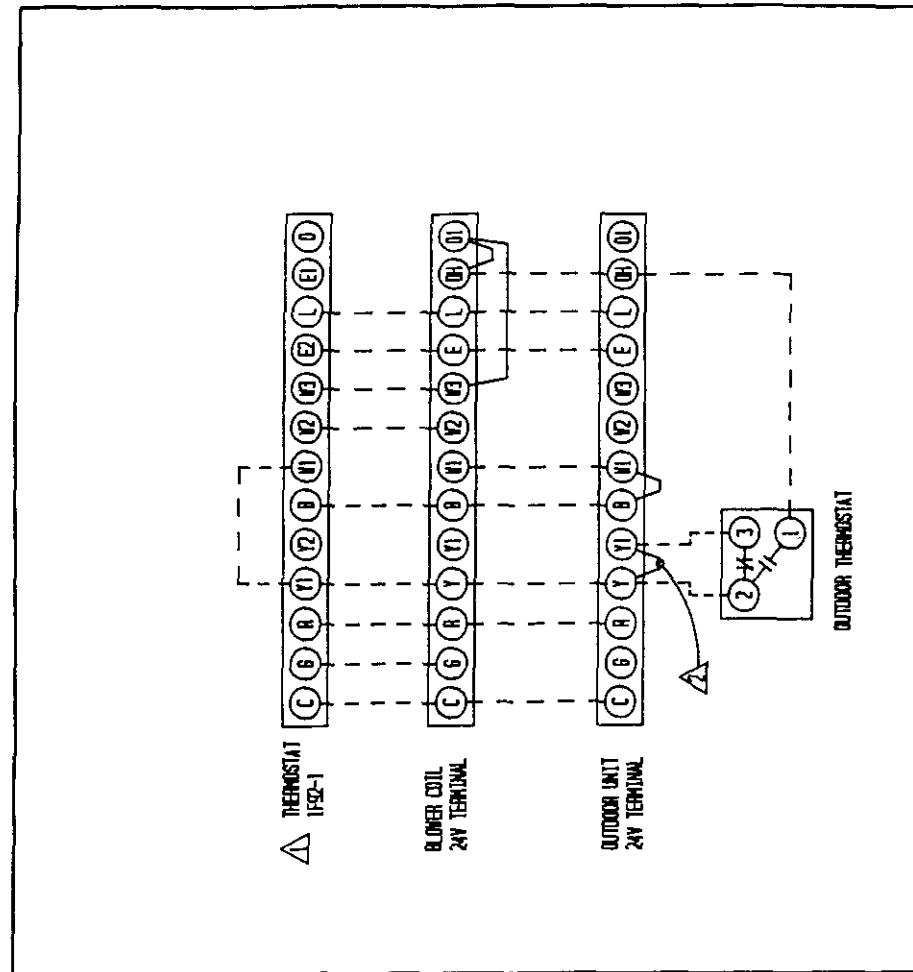

▲ THERMOSTAT 1F92-1
 BLOWER COIL 24V TERMINAL
 OUTDOOR UNIT 24V TERMINAL
 OUTDOOR THERMOSTAT

▲ OPTION SWITCH SETTING
 SWITCH #1 'OFF'
 SWITCH #2 'OFF'
 SWITCH #3 'OFF'
 SWITCH #4 SEE THERMOSTAT INSTALLATION INSTRUCTIONS

ON 1 2 3 4

FACTORY WIRING _____
 FIELD WIRING _____

LOW VOLTAGE _____
 HIGH VOLTAGE _____

HEATPUMP V/S OR SNV BLOWER COIL

▲ IF OUTDOOR THERMOSTAT (USED AS COMPRESSOR CUTOFF) IS INSTALLED, REMOVE JUMPER Y-Y1.

4081-805

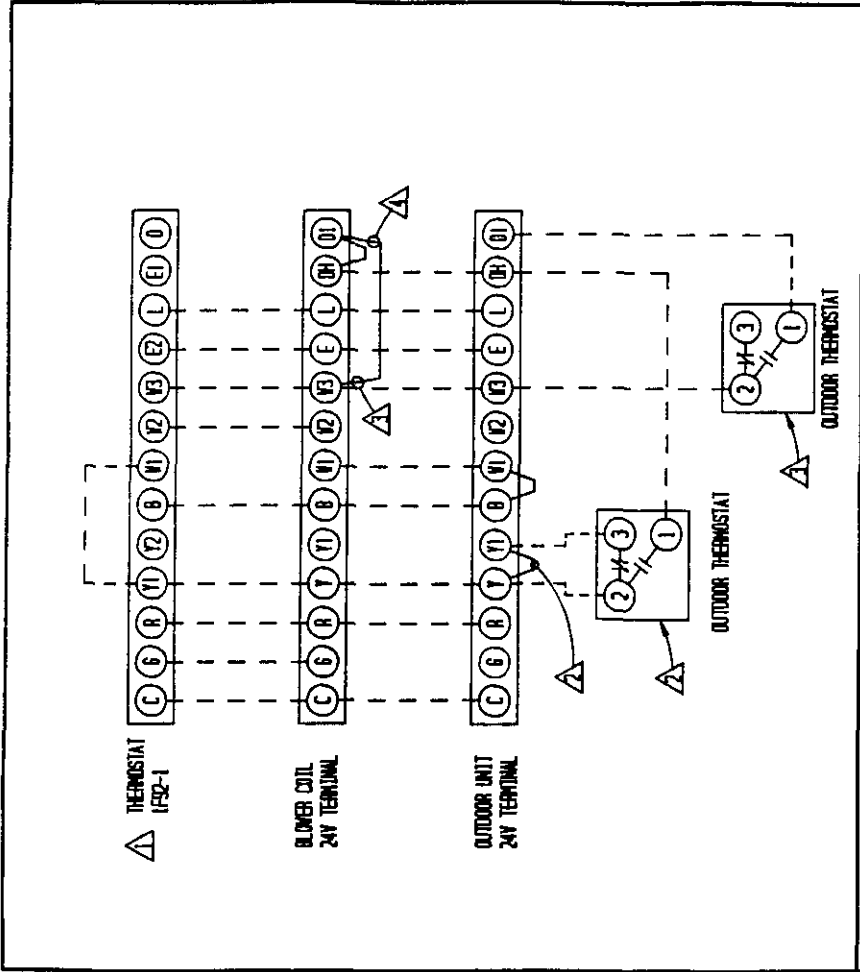

OPTION SWITCH SETTING

SWITCH #1 'OFF'

SWITCH #2 'OFF'

SWITCH #3 'OFF'

SWITCH #4 SEE THERMOSTAT INSTALLATION INSTRUCTIONS



- △ IF OUTDOOR THERMOSTAT (USED AS COMPRESSOR CUTOFF) IS INSTALLED, REMOVE JUMPER Y-Y1.
- △ IF OUTDOOR THERMOSTAT IS USED TO STAGE HEAT, REMOVE JUMPER V3-O1.
- △ FOR COUNTERFLOW APPLICATIONS, REMOVE JUMPER V3-O1.

HEATPUMP 1/4 OR LARGER BLOWER COIL

FACTORY WIRING	FIELD WIRING
LOW VOLTAGE	---
HIGH VOLTAGE	---

4101-007

WALL THERMOSTATS

The following wall thermostats and subbases should be used as indicated, depending on the application.

TABLE 14

AIR CONDITIONING THERMOSTATS		
Part No.	Model No.	Description
8403-002	T87F3111	THERMOSTAT--1 stg. heat, adj. heater, Mercury
8404-003	Q539A1220	SUBBASE --System Heat-Off-Cool Fan: On-Auto
8403-008	ID51-605	THERMOSTAT--1 stg. cool, System w/Off Sw. Snap Action Fan: Auto-On
8403-009	IF56-318	THERMOSTAT--1 st. cool, 1 stg. heat, Adj. heater Mercury System: Heat-Off-Cool Fan: Auto-On
8403-019	T874C1000	THERMOSTAT--1 stg. cool, 2 stg. heat, Adj. heater, Mercury
8404-012	Q674A1001	SUBBASE --System: Heat-Auto-Cool Fan: Auto-On
HEAT PUMP THERMOSTATS		
Part No.	Model No.	Description
8403-017	T874R1129	THERMOSTAT--1 stg. cool, 2 stg. heat, 1st stage fixed, 2nd stg. adj. heat anticipators
8404-009	Q674L1181	SUBBASE --System switch: Em. Heat-Heat-Off-Cool Fan switch: On-Auto SPECIAL FEATURE: Manual Changeover (Non-Cycling Rev. Valve) Em. heat light and System check light
8403-018	T874N1024	THERMOSTAT--1 stg. cool, 2 stg. heat, 1st stage fixed, 2nd stg. adj., heat anticipators
8404-010	Q674F1261	SUBBASE --System switch: Off-Cool-Auto-Heat-Em.Ht. Fan switch: On-Auto SPECIAL FEATURE: Auto system changeover, Em. heat light and System check light
8403-024	IF58-45	THERMOSTAT--1 stg. cool, 2 stg. heat, 1st stage fixed, 2nd stg. adj. heater System switch: Em. Heat-Heat-Off-Cool Fan Switch: On-Auto
8403-027	IF92-1	THERMOSTAT--2 stg. cool, 3 stg. heat, electronic SUBBASE --Manual or automatic changeover, 2 set-up/set-back periods per day, 5 or 7 day programming

CONNECTION DIAGRAM

DANGER: ELECTRICAL SHOCK HAZARD.
DISCONNECT POWER BEFORE SERVICING.

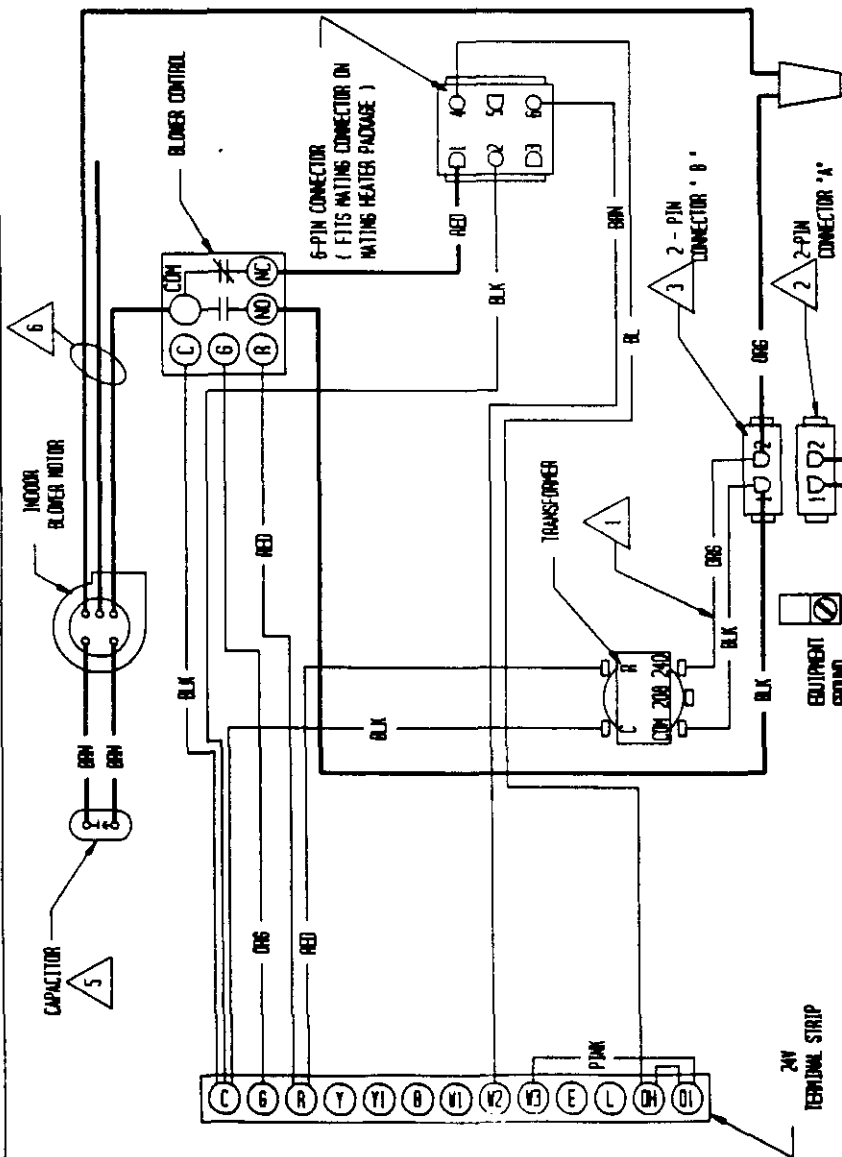

- 1 FOR 200V OPERATION MOVE THIS WIRE TO THE 200V TRANSFORMER TAP
- 2 2-PIN CONNECTOR 'A' USED FOR FIELD CONNECTION WHEN NO HEATER PACKAGE IS INSTALLED.
- 3 WHEN HEATER PACKAGE IS INSTALLED, CONNECTOR 'B' CONNECTS TO MATING CONNECTOR ON HEATER PACKAGE.

- 4 REFER TO INSTALLATION INSTRUCTIONS FOR CONTROL CIRCUIT WIRING

FACTORY WIRING	FIELD WIRING
---	---
---	---
---	---
---	---

Low Voltage
High Voltage

LADDER DIAGRAM

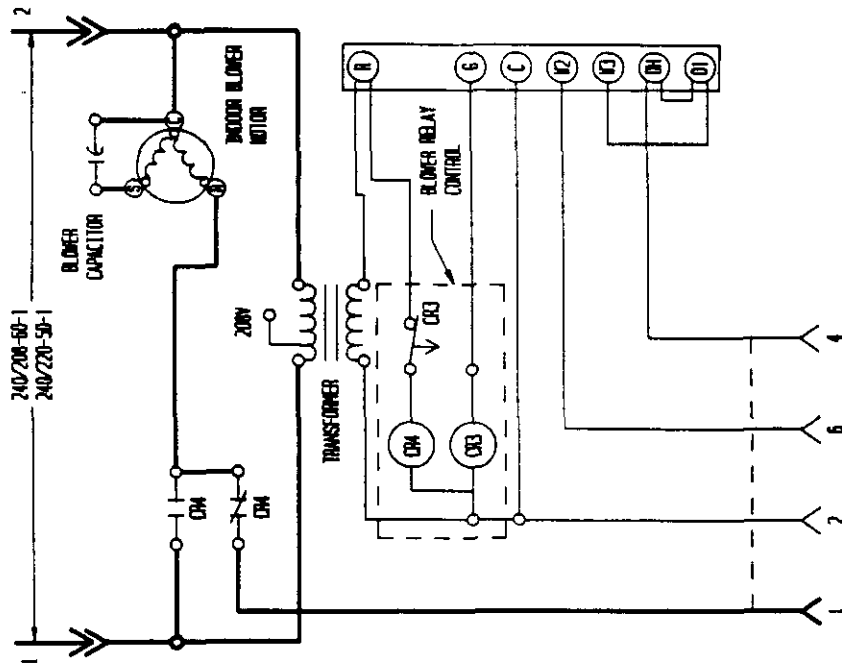

MODEL	CAPACITANCE
BC248	5/370
BC358	7.5/440
BC368	
BC488	7.5/440
BC508	

WIRE COLOR	MOTOR SPEED
YELLOW	COMMON
BLACK	HIGH
BLUE	MEDIUM (BC248, BC358 ONLY)
RED	LOW