

INSTALLATION INSTRUCTIONS

MC90 MASTER CONTROLLER

MANUAL 2100-173
SUPERSEDES REV. --
FILE VOL. III, TAB 19

COPYRIGHT NOVEMBER, 1990
BARD MANUFACTURING COMPANY
BRYAN, OHIO

TABLE OF CONTENTS

1.	Important	1
2.	Shipping Damage	1
3.	General	1
4.	Theory Of Operation	1
	A. Timer	1
	B. Alarm Circuits	1
	1. Power Loss Alarm	2
	2. High Temperature Alarm	2
	3. Low Temperature Alarm	2
	C. Mode Switch	2
	D. Thermostat	2
5.	Sequence Of Operation	2
	A. Redundant Mode--No Economizers	2
	1. Cooling	2
	2. Heating	2
	A. Economizer Mode	3
	1. Cooling	3
	2. Heating	3
6.	Installation Instructions	3
	A. Unpacking	3
	B. High Voltage Phasing	3
	C. Low Voltage Field Wiring	4
	D. Alarm Circuit Wiring	4
	1. Power Loss Alarm	4
	E. Thermostat	4
7.	System Checkout And Adjustment	5
8.	Troubleshooting	6
	A. General	7
	B. Timer	7
	C. Unit #1 & Unit #2	8
	D. Power Loss.	8
	E. Low Temp Alarm.	9
	F. High Temp Alarm	10
9.	Wiring Diagram and Component Locations.	13

FIGURES

Figure 1	Low Voltage Connections	11
Figure 2	Alarm Thermostat Temperature Settings	12
Figure 3	Wiring Diagram.	13
Figure 4	Component Locations	14

IMPORTANT

The equipment covered in this manual is to be installed by trained, experienced service and installation technicians. Please read entire manual before proceeding.

SHIPPING DAMAGE

Upon receipt of equipment, the carton should be checked for external signs of shipping damage. If damage is found, the receiving party must contact the last carrier immediately, preferably in writing, requesting inspection by the carrier's agent.

GENERAL

These instructions explain the operation, installation and troubleshooting of the MC90 controller.

All internal wiring is complete. Only attach low voltage field wiring to designated terminal strips.

The controller is for use with air conditioning wall mount series units only. The air conditioner units must be identical with or without economizers.

Each unit should be sized to handle the total load of the structure.

THEORY OF OPERATION

The MC90 is used to control two wall mount air conditioners from one thermostat. It provides total redundancy for the structure and equal wear on both units. It can be used with or without economizers on the air conditioner units but both units must be equipped alike. See Figure 4 for component locations.

TIMER

The timer is a 24 hour on/off timer. Once every 24 hours the timer contacts switch positions. This determines which unit will be the primary unit and which will be the secondary unit for the next 24 hour period. At the end of this 24 hour period, the contacts switch again and the primary unit becomes the secondary unit and vice versa. Every 24 hours the primary and secondary units switch providing equal wear on the units. This is done by energizing or de-energizing relays R1 and R2 every 24 hours.

ALARM CIRCUITS

The MC90 is equipped with three (3) alarm circuits: power loss alarm, high temperature alarm and low temperature alarm.

All alarm circuits have both normally open and normally closed dry contacts.

Power Loss Alarm

The power loss alarm relay, R5, is normally energized. Upon power loss to both units, the relay will de-energize and switch contact positions sending the alarm.

High Temperature Alarm

The high temperature alarm thermostat energizes the high temperature alarm relay, R4, and an interlock relay, (R6), that ensures that both units are on line if the high temperature alarm thermostat setpoint is exceeded. The interlock relay is necessary when the MC90 is used with units equipped with economizers.

Low Temperature Alarm

The low temperature thermostat energizes the low temperature alarm relay, R3, if the temperature of the structure drops below the low alarm thermostat setpoint.

MODE SWITCH

This switch sets the controller for economizer or mechanical mode. The sequence of operation is different for each mode. See the sequence of operation section for specifics. The economizer mode sets the controller for use with units equipped with economizers on both units. The mechanical mode sets the controller for use with units without economizers on either unit.

THERMOSTAT

As in normal installations, the thermostat is the primary control of the room conditions. The thermostat is equipped with a heating setpoint lever, cooling setpoint lever, system off-auto switch, and fan switch. The fan switch is unused and should be left in the auto position.

SEQUENCE OF OPERATION

MECHANICAL MODE--NO ECONOMIZERS

Cooling

1. On a call by the thermostat for first stage cooling, the compressor and fans of the primary unit will be energized.
2. On a call for second stage cooling, the compressor and fans of the secondary unit will be energized.
3. If the temperature continues to climb and the high alarm setpoint is exceeded, the high temperature alarm relay is energized and an alarm is sent.

Heating

1. On a call by the thermostat for first stage heat, the electric heat in the primary unit will be energized.
2. On a call by the thermostat for second stage heat, the electric heat of the secondary unit will be energized.
3. If the temperature continues to fall and the low alarm setpoint is exceeded, the low temperature alarm relay is energized and an alarm is set.

ECONOMIZER MODE

Cooling

1. On a call for first stage cooling, the blower and economizer of the primary unit is energized.
2. On a call for second stage cooling, the compressor and fans of the primary unit are energized and the economizer is de-energized.
3. If the high alarm setpoint is exceeded, the high alarm relay is energized, sending an alarm, and the interlock relay is energized which brings on the compressor and fans of the secondary unit.

Heating

1. On a call by the thermostat for first stage heat, the electric heat in the primary unit will be energized.
2. On a call by the thermostat for second stage heat, the electric heat of the secondary unit will be energized.
3. If the temperature continues to fall and the low alarm setpoint is exceeded, the low temperature alarm relay is energized and an alarm is set.

INSTALLATION INSTRUCTIONS

UNPACKING

1. Included in the MC90 carton are two packages: 1. The T874D1009 thermostat, and 2. the MC90 controller. The thermostat subbase is installed on the MC90 controller.

Set aside the thermostat for now as it will be installed last.

2. The MC90 should be installed on a vertical wall approximately four (4) feet above the floor away from drafts and outside doors or windows. Four (4) mounting holes are provided for mounting to the wall and holes for conduit connections are provided in both the base and bottom of the controller. The MC90 should not be mounted directly to a block wall, space away from wall with insulation or plywood.

IMPORTANT: The subbase and thermostat must be level for proper operation.

HIGH VOLTAGE PHASING

CAUTION

Before connecting any low voltage connections, the units must be phased alike to insure proper operation of the transformers in parallel.

Determining if units are phased correctly:

1. Both units must be supplied from the same electrical service.
2. Connect a voltmeter between the L1 line connections of the two units. Record the voltage.
3. Connect the voltmeter between the L2 line connections of the two units. Record the voltage.
4. If the voltages are 0 or nearly 0, the units are phased correctly. If the voltages are 240 volts or slightly less, the units are out of phase. Disconnect power to units and interchange L1 and L2 power leads on one unit. Reconnect power and repeat to verify proper phasing.

LOW VOLTAGE FIELD WIRING

Connect the low voltage field wiring from each unit per the low voltage field wiring diagrams in Figure 1.

CAUTION

For proper blower operation, G must be jumpered to the Y terminal at the unit in systems without economizers. G must be jumpered to the Y1 lead of the wiring harness of the economizer in systems with economizers.

ALARM CIRCUIT WIRING

All alarm circuit contacts are dry contacts. Contact ratings are:

12 FLA 60 LRA @ 24 VAC

Do not exceed these ratings when wiring your alarm circuit application. Contacts should be used for low voltage applications only.

Power Loss Alarm

Terminal identifications on the power loss alarm circuit represent contact positions in the normal power-on operating condition. When wiring the power loss alarm with no power applied, the contact positions will be opposite of terminal identifications.

THERMOSTAT

Do not install the thermostat until all low voltage connections have been made to the controller and the wiring has been checked for accuracy.

Remove the thermostat from the box. It should include:

- A. Thermostat T874D1009
- B. Instructions

1. Read the thermostat instructions before proceeding.
2. Remove the thermostat cover by pulling outward on the bottom of the cover.
3. Remove thermostat interpacking.
4. Position thermostat heat lever to far left.
5. Position thermostat cool lever to far right.
6. Position subbase system switch to off.
7. Position subbase fan switch to auto.
8. Install thermostat on subbase per the manufacturer's instructions.

This completes installation of the MC90.

SYSTEM CHECKOUT ADJUSTMENT

Refer to Figure 3 for component locations and wiring diagram.

1. Turn high alarm thermostat to off. Turn low alarm thermostat to off.
2. Set mode switch to mechanical for use without economizer. Set mode switch to economizer for use with economizer.
3. Thermostat system and fan switches should be off, the thermostat heating level should be to the far left and the cooling level to the far right.
4. After checking units for proper phasing, apply power to both units.
5. Follow initial start up procedures on side of unit.

Failure to follow these procedures may result in compressor failure.

6. Temporarily remove the wire from terminal 1 of the timer. See Figure 4.
7. If not equipped with an economizer, proceed to Step 8. If units are equipped with an economizer, perform economizer checkout at this time as detailed in the economizer installation instructions with these exceptions.
 - A. The instructions request the manual fan switch position in Step B. This is a non-functional switch on the MC90. To simulate this, remove the field installed jumper between G and Y1 on the Unit 1 low voltage block (temporarily). Install jumper from R to G and proceed with economizer checkout of primary unit. See Figure 1.
 - B. In Step G when asked to switch thermostat control to automatic, remove the jumper from R to G and replace the G to Y1 jumper on the Unit 1. Finish economizer checkout, then proceed to Step 9.
8. For units without economizers, set system switch to on. Move cooling level slowly to the left to engage first stage cool. Compressor and blower of Unit 1 should start. Move the cooling level further left to engage second stage cooling. The compressor and blower of Unit 2 should start. Reset cooling lever to left.

9. Move heating lever slowly to the right until first stage heating is engaged. The electric heat and blower of Unit 1 should come on.

Move heating lever further to the right to engage second stage heat. The electric heat and blower of Unit 2 should come on.

Reset heating lever to left.

10. Place a jumper between R and the wire removed from terminal 1 of the timer.

Repeat Steps 7 through 9 replacing the phrase, "Unit 1" with "Unit 2" and vice versa.

11. Remove jumper and reattach the wire to terminal 1 of the timer.
12. Adjust low alarm thermostat setpoint to a temperature above room temperature. The low alarm circuit should activate if employed. Return low alarm thermostat to desired setpoint in operation. This must be at least 5 degrees below the desired heating lever setpoint. See Figure 2.
13. Adjust the high alarm setpoint to a temperature below room temperature. If employed, the high alarm circuit should be activated. Return high alarm thermostat to the desired setpoint. In operation, this should be at least 5 degrees above the cooling lever setpoint. See Figure 2.
14. Set heating and cooling temperature levers to the desired operating setpoints. Check the high alarm thermostat setpoint to make sure that it is at least 5 degrees above the first stage cooling setpoint temperature. Check the low alarm thermostat to make sure it is at least 5 degrees below the first stage heating setpoint temperature.
15. Set thermostat heat anticipators per directions in thermostat instructions.
16. Remove jumper between terminals 6 and 7 of timer. Relays 1 and 2 should be heard switching approximately every 10 seconds. This indicates proper timer function.

This completes system checkout.

TROUBLESHOOTING

The troubleshooting section is divided into three sections.

1. General
2. Time
3. Alarm Circuits

Always perform general troubleshooting section before performing any other section.

GENERAL TROUBLE SHOOTING PROCEDURES

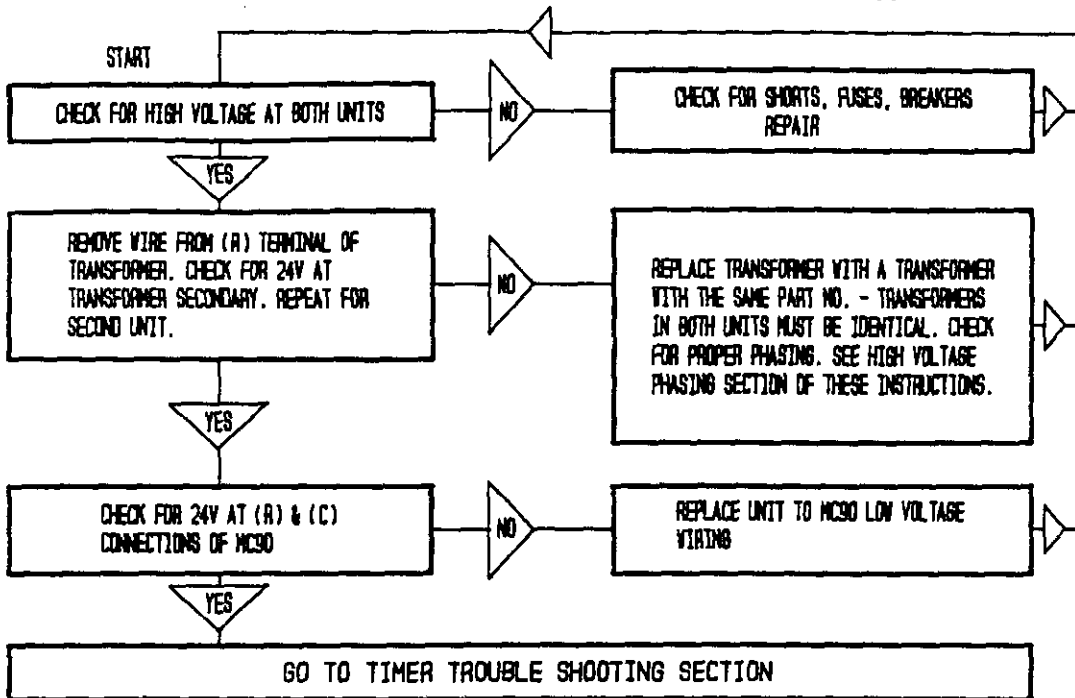

TIMER SECTION - TROUBLE SHOOTING THE TIMER AND ITS RELATED RELAYS (R1) & (R2)

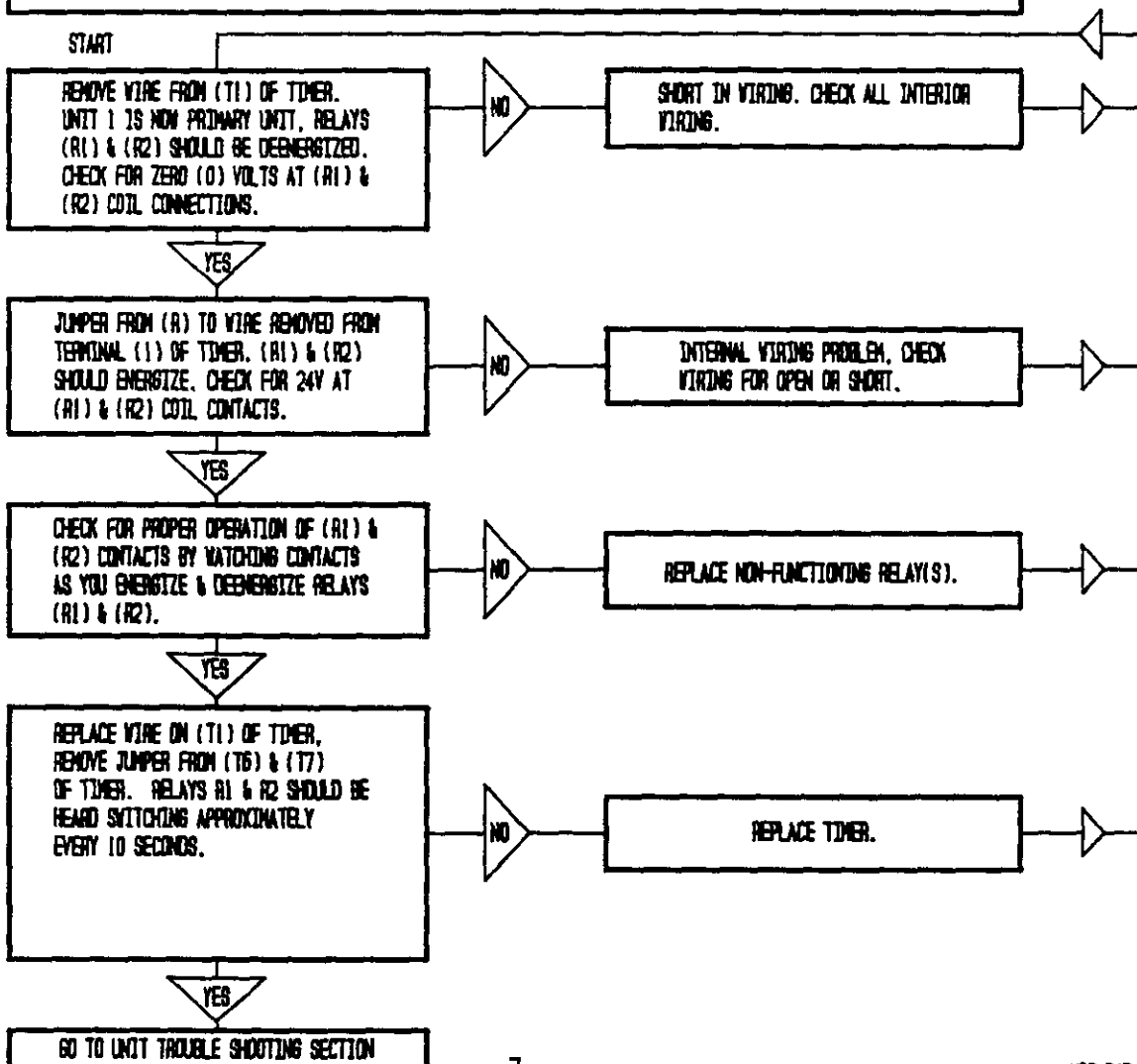

UNIT SECTION - TROUBLE SHOOTING UNITS #1 & #2

UNIT #1

YES

REMOVE WIRE FROM (T1) OF TIMER. UNIT NOW PRIMARY UNIT. PERFORM NORMAL TROUBLE SHOOTING TECHNIQUES ON UNIT ONE ELECTRICAL & REFRIGERATION COMPONENTS. USE SEQUENCE OF OPERATION TO VERIFY PROPER OPERATION OF UNIT, THERMOSTAT, AND ECONOMIZER.

UNIT #2

YES

REMOVE WIRE FROM (T1) OF TIMER & JUMPER TO (R). UNIT 2 IS NOW PRIMARY UNIT. PERFORM NORMAL TROUBLE SHOOTING TECHNIQUES ON UNIT TWO ELECTRICAL & REFRIGERATION COMPONENTS. USE SEQUENCE OF OPERATIONS TO VERIFY PROPER OPERATION OF UNIT, THERMOSTAT, AND ECONOMIZER.

POWER LOSS ALARM CIRCUIT TROUBLESHOOTING

START

CHECK FOR 24V AT COIL TERMINALS OF (RS)

NO

CHECK INTERNAL WIRING FOR BREAK IN (R) OR (C) TO (RS) COIL TERMINALS & REPAIR.

YES

REMOVE WIRE FROM TERMINAL (1) OF (RS) AND LISTEN FOR CONTACTS MAKING OR BREAKING

NO

REPLACE RELAY

YES

POWER LOSS ALARM - OK

LOW TEMPERATURE ALARM - TROUBLE SHOOTING PROCEDURE

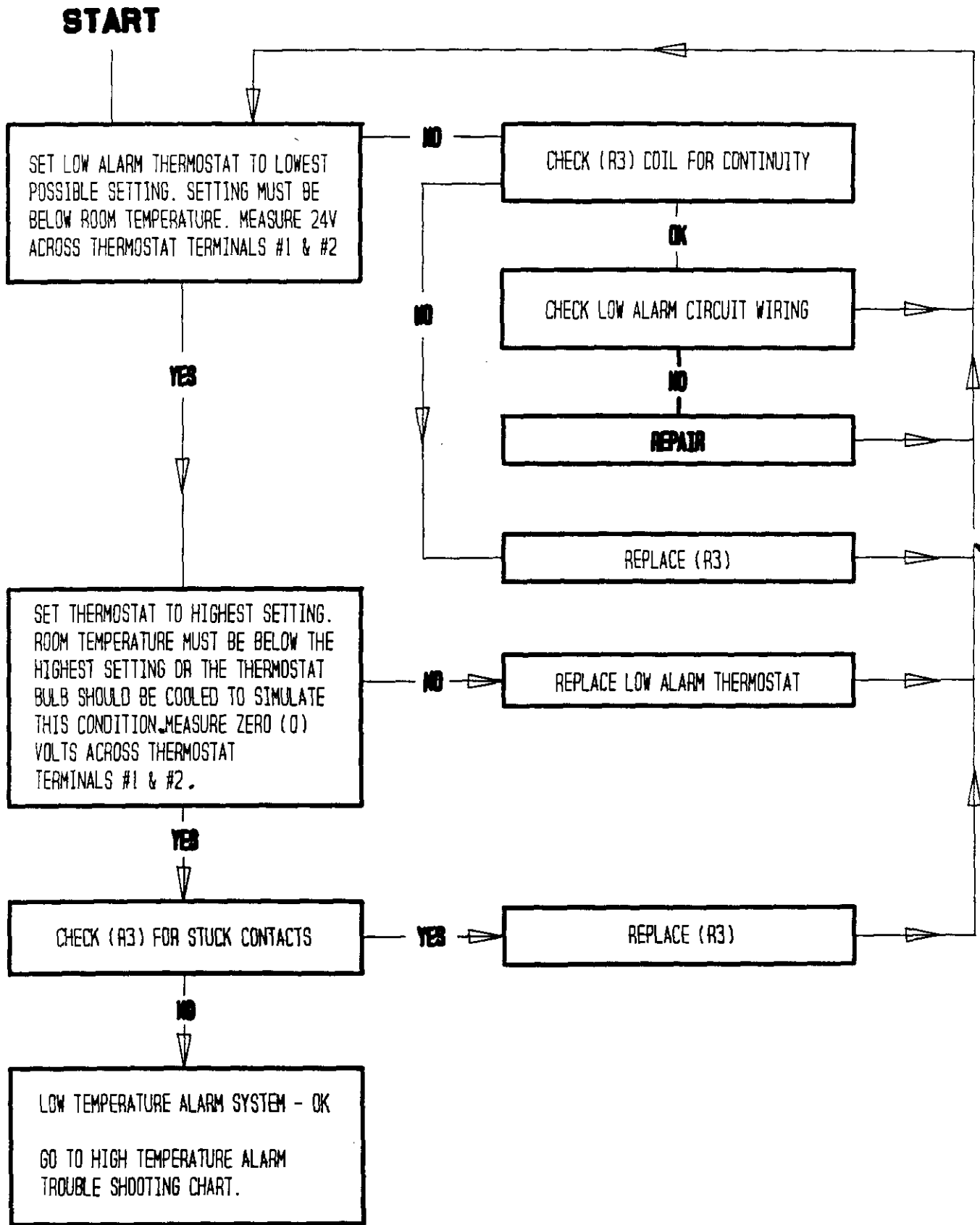

LOW VOLTAGE CONNECTIONS WITH ECONOMIZER

FIG. 1

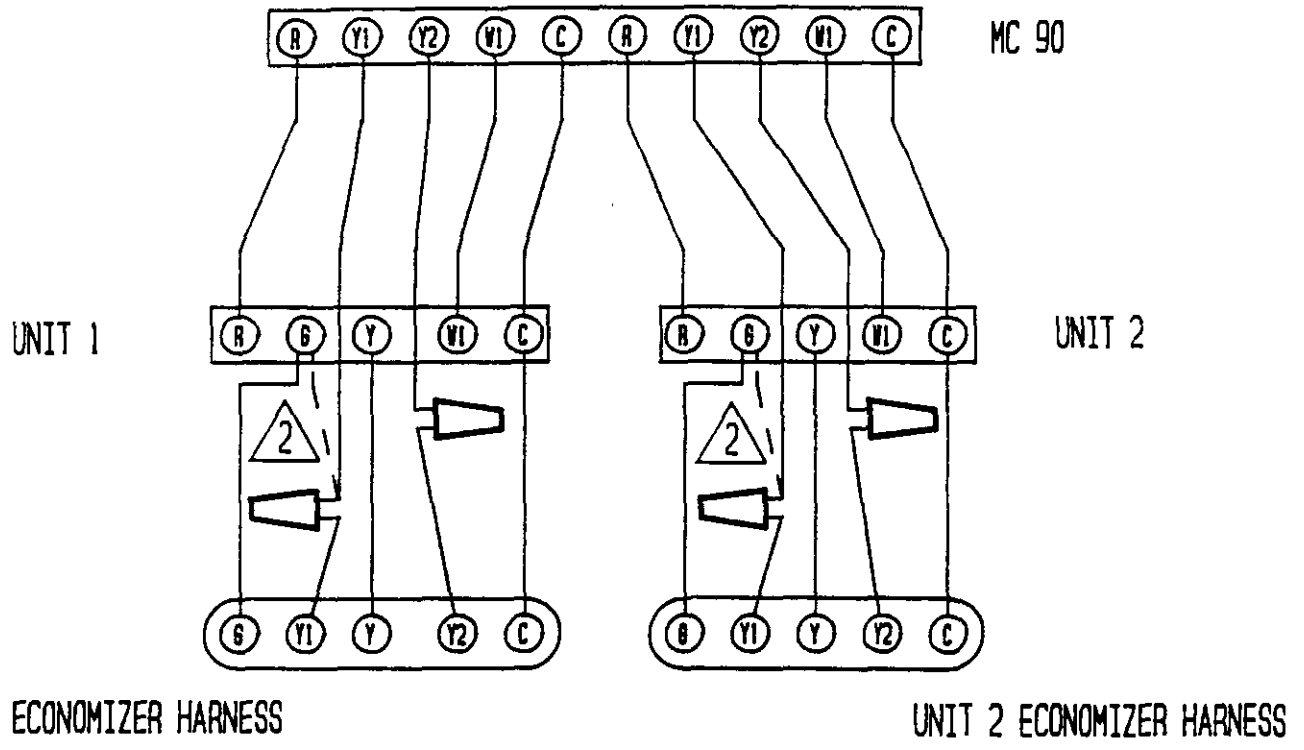

LOW VOLTAGE CONNECTIONS, NO ECONOMIZER

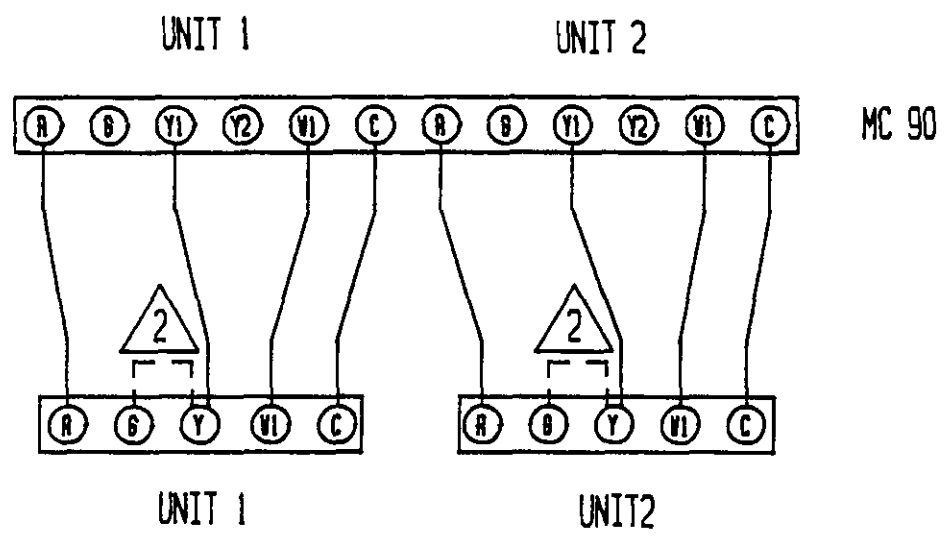

 JUMPER MUST BE INSTALLED FOR PROPER BLOWER OPERATION

THERMOSTAT NUMBER - TEMPERATURE CONVERSION

FIG. 2

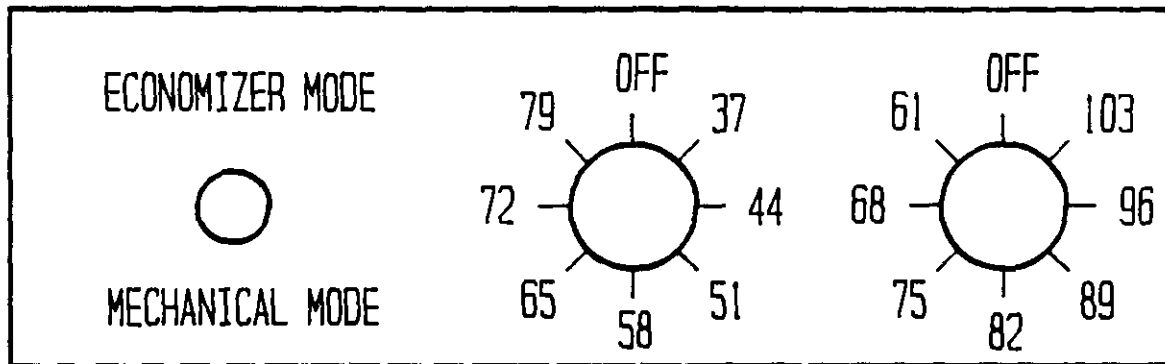

LOW ALARM
THERMOSTAT

HIGH ALARM
THERMOSTAT

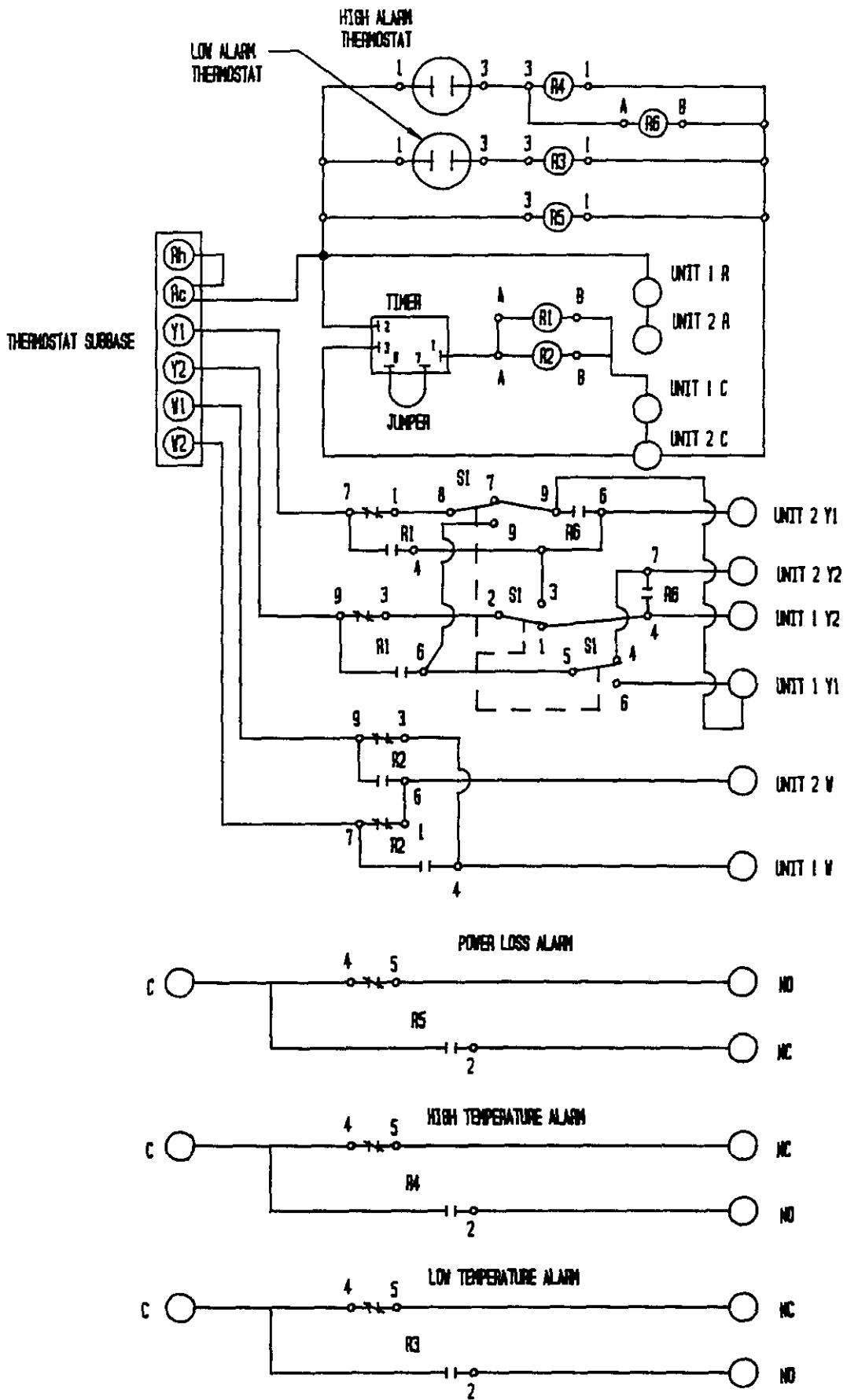

THERMOSTAT ----- PART # 8403-021
 SUBBASE ----- PART # 8404-013
 LOW ALARM THERMOSTAT -- PART # 8408-021
 HIGH ALARM THERMOSTAT - PART # 8408-022
 SWITCH (S1) ----- PART # 8406-050
 RELAYS (R5, R4, R3) --- PART # 8201-009
 RELAYS (R6, R2, R1) --- PART # 8201-048
 TIMER ----- PART # 8612-014

