

INSTALLATION INSTRUCTIONS

MODELS

WAG30A-A54C,X
WAG36A-A54C,X
WAG36A-B54C,X
WAG36A-C54C,X
WAG40A-A54C,X
WAG40A-B54C,X
WAG40A-C54C,X

**THE WALL-MOUNT HI-BOY
COMBINATION GAS/ELECTRIC**

MANUAL 2100-149 REV. L
SUPERSEDES REV. K
FILE VOL. III, TAB 20

COPYRIGHT FEBRUARY, 1989
BARD MANUFACTURING COMPANY
BRYAN, OHIO

TABLE OF CONTENTS

Important	2
Transportation Damage	2
General Application	3
Mounting Instructions	4
Installation.	6
Clearances.	6
Duct Work	6
FIELD INSTALLED COMPONENTS	7
Mounting Brackets	7
Vent Terminal And Induced Draft Blower Hood	7
Vent Resizing Instructions	7
Vent Troubleshooting Procedures	8
Fresh Air Damper Assembly	8
Filter	8
Wall Mounting	9
Wiring - Main Power	9
Electrical Grounding	9
A. Recommended Grounding Method	9
B. Alternate Grounding Method	10
Thermostat	10
GAS SUPPLY AND PIPING	10
General Recommendations	10
Checking The Gas Piping	11
Determining Gas Input--Natural Gas	12
Determining Gas Input--LP Gas	12
Gas Pressure Specifications	12
Lighting and Shutdown Instructions	13
Service Agency Procedures	14
Burners/Heat Exchanger/Flue Gas Passage Ways	14
INSPECTION AND CLEANING OF BURNERS AND HEAT EXCHANGERS	15
Maintenance Instructions	15
Routine Maintenance	15
Routine Inspection	15
Replacement Parts	16
Sequence of Operation--Heating	16
Sequence of Operation--Cooling	16
S8600H Intermittent Pilot System Troubleshooting	17
Blower Operation	18
Standard Orifice Sizing and High Altitude Derate	19
Pressure Service Ports	21
Refrigerant Charge	21
Fan Blade Setting Dimensions	21
Conversion of Gas Input BTUH	22
LO-NOx Burner Assembly (X Suffix Models Only)	23
Wiring Diagrams	24

FIGURES AND TABLES

Figure 1	4
Figure 2	5
Figure 3	5
Figure 4	11
Figure 5	11
Figure 6	13
Figure 7	14
Figure 8	14
Figure 9	14
Figure 10.	18
Figure 11.	20
Figure 12.	22
Figure 13.	23
Figure 14.	8

Table 1	1
Table 2	8
Table 3	11
Table 4	11
Table 5	12
Table 6	19
Table 8	21
Table 9	21
Table 10	23

TABLE 1
SPECIFICATIONS*

MODEL	WAG30A-A54C	WAG36A-A54C	WAG36A-B54C	WAG36A-C54C	WAG40A-A54C	WAG40A-B54C	WAG40A-C54C
Cooling Capacity Btuh	30,000	35,000	35,000	35,000	38,500	38,500	38,500
Heating Input (M/Btuh)	65/55	65/55	65/55	65/55	65/55	65/55	65/55
*Heating Output (M/Btuh)	51/43	51/43	51/43	51/43	51/43	51/43	51/43
Temp. Rise Range	50-80	50-80	50-80	50-80	50-80	50-80	50-80
Electrical Rating--60HZ							
Operating Voltage Range	197-253	197-253	187-253	414-506	197-253	187-253	414-506
Minimum Circuit Ampacity	22	27	20	15	31	23	15
*Field Wire Size/Ground Wire Size	10/10	10/10	12/12	14/14	8/10	10/10	12/12
**Delay Fuse--Max	35	40	30	15	50	35	20
Total Unit Amps 230/208	15.7/17.2	19.1/21.1	15.1/16.1	9.1	22.1/24.6	16.1/18.6	11.1
Compressor--Circuit A							
Volts	230/208	230/208	230/208	460	230/208	230/208	460
Rated Load Amps 230/208	12.5/14.0	15.0/17.0	11/12	7	18/20.5	12/14.5	9
Branch Circuit Selection Current	15	18	12	7	21.5	14.5	9
Lock Rotor Amps	76	83.5	66	35	95.4	82	41
Fan Motor & Condenser							
Fan Motor--HP/RPM	1/5 / 1090		1/3 / 1110			1/3 / 1110	
Fan Motor--Amps	1.4		2.3			2.3	
Fan--DIA/CFM	20/2100		20/2100			20/2100	
Face Area	5.04/ 2/13		5.04/ 3/11			5.04/ 3.11	
Sq Ft/Row/Fins per inch							
Motor and Evaporator							
Blower Motor--HP/RPM	1/3 / 1085		1/3 / 1085			1/3 / 1085	
Blower Motor--Amps	1.8		1.8			1.8	
CFM Cooling & E.S.P.	1000/.15		1000/.15			1000/.15	
w/Filter (Rated)							
Face Area	3.21/ 2/13		3.21 / 3/13			3.21 / 3/13	
Sq Ft/Row/Fins per inch							
Filter Sizes (inches)	20x30x1		20x30x1			20X30X1	
Refrigerant 22--oz.	66-1/2	94-1/2	94-1/2	94-1/2	88	88	88
Shipping Weight--lbs.	420	420	420	420	420	420	420

*60 degree C Copper wire size.

**Maximum time delay fuse or HACR Type circuit breaker.

+All capacity, efficiency, and cost of operation information is in accordance with DOE and/or ARI test procedures. This information is based on high speed cooling and low speed heating operation using a fresh air cover plate. Cover plate must be ordered separately and is recommended for use to obtain maximum energy efficiency where fresh air opening is not required.

++Units shipped with high input orifices installed. Low input orifices are included for field changeover.

Nomenclature Explanation

Example:

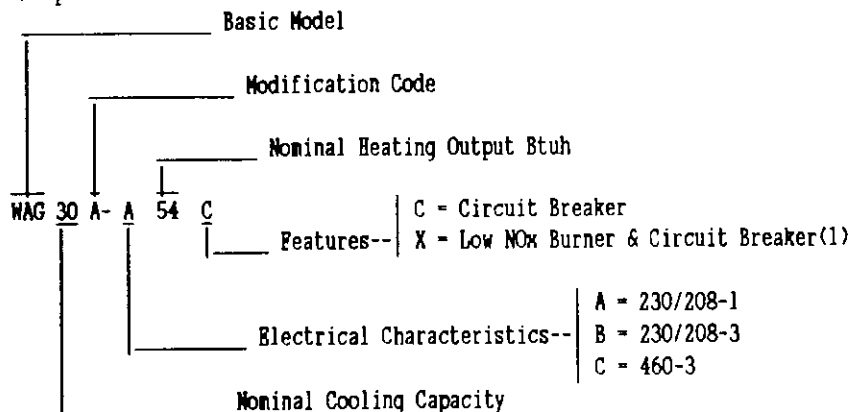

IMPORTANT

While this electrical data is presented as a guide, it is important to electrically connect, properly sized fuses and conductor wires in accordance with the National Electrical Code and all existing local codes.

(1) "X" suffix low NOx models not approved for LP gas conversion.

IMPORTANT

The equipment covered in this manual is to be installed by trained, experienced service and installation technicians. All duct work supply and return, must be properly sized for the design air flow requirement of the equipment. ACCA is an excellent guide to proper sizing. All duct work or portions thereof not in the conditioned space should be properly insulated in order to both conserve energy and prevent condensation or moisture damage.

TRANSPORTATION DAMAGE

You, the receiver, are responsible for following proper procedures in the process of recovering for any freight damage.

All units are packed in new, reinforced shipping containers when they leave the manufacturer. At the time of delivery, all containers should be carefully inspected for signs of being crushed, punctured, and or being shipped in the wrong position.

If any carton is questionable, you should:

1. Open the carton and inspect the contents immediately with the delivery person present.
2. Note any damage on the carrier's delivery receipt before you sign it.
 - A. If the situation is such that it is impossible to inspect the contents or the driver does not want to wait, note the number of cartons damaged and write the words "damage" (or "shortage" if your shipment is not complete).
 - B. Do not make notations on the receipt such as "possible damage" or "subject to inspection" on the receipt. Declare "damage." If, after your inspection, the product is in good condition, you need take no further action with the carrier.
3. Inspect all freight immediately after delivery for hidden damage, even though the carton appears good and you noted no damage on the deliver receipt. If damage is discovered in an otherwise clean carton, notify the carrier within 24 hours of delivery. Sometimes carriers can legally refuse paying claims after a few days have passed with the product in your possession.

In all cases of damage:

1. Do not move the damaged item(s) any further than necessary from the delivery point. You are responsible for keeping it safe from any further damage.
2. Always save the packaging for inspection. It is your "proof" of claim, especially for hidden damage.
3. Call the carrier's office immediately and request an inspection and claim form (note the name of the person you spoke to). If you receive no response within 15 days, notify the carrier again. He is legally required to respond to your claim.
4. After inspection, submit the claim form along with all required copies of the bill-of-lading, packing sheet, invoice showing your cost of the unit, and signed freight bill. Make sure you have copies. You must file the claim even after inspection.
5. Your claim will be assigned a number and the carrier has 120 days to respond by paying or refusing your claim.
6. If you feel your claim is not being properly recognized after several attempts to recover, contact your nearest Interstate Commerce Commission office for interstate freight or State Commerce office for freight shipped within the state.

GENERAL APPLICATION

The unit is designed for use with or without duct work. See important note below. Flanges are provided for attaching the supply and return ducts. These instructions explain the recommended method to install the air cooled self-contained unit and the electrical wiring connections to the unit. The refrigerant system is completely assembled and charged. All internal wiring is complete.

These instructions and any instructions packaged with any separate equipment required to make up the entire air conditioning system should be carefully read before beginning the installation. Note particularly "Starting Procedure" and any tags and/or labels attached to the equipment.

The gas/electric installation must conform with local building codes and ordinances or, in their absence with the National Fuel Gas Code, ANSI Z223.1-latest edition, and the National Electrical Code, ANSI/NEPA 70-latest edition. It is the personal responsibility and obligation of the purchaser to contract a qualified installer to assure that installation is adequate and is in conformance with governing codes and ordinances. Authorities having jurisdiction should be consulted before the installation is made.

IMPORTANT: *In all cases, there must be a metal duct connection made to the supply air flange, and a one inch clearance to combustibles must be maintained to this duct connection.*

For free blow applications, a metal sleeve must be used in the wall opening itself, again maintaining a one inch clearance to combustibles.

See Figure 1 on page 4 and clearance information on page 5 for additional information.

IMPORTANT: "C" suffix models approved for LP gas conversion using 9010-045C conversion kit.

"X" suffix low NOx models not approved from LP gas conversion.

FIGURE 1

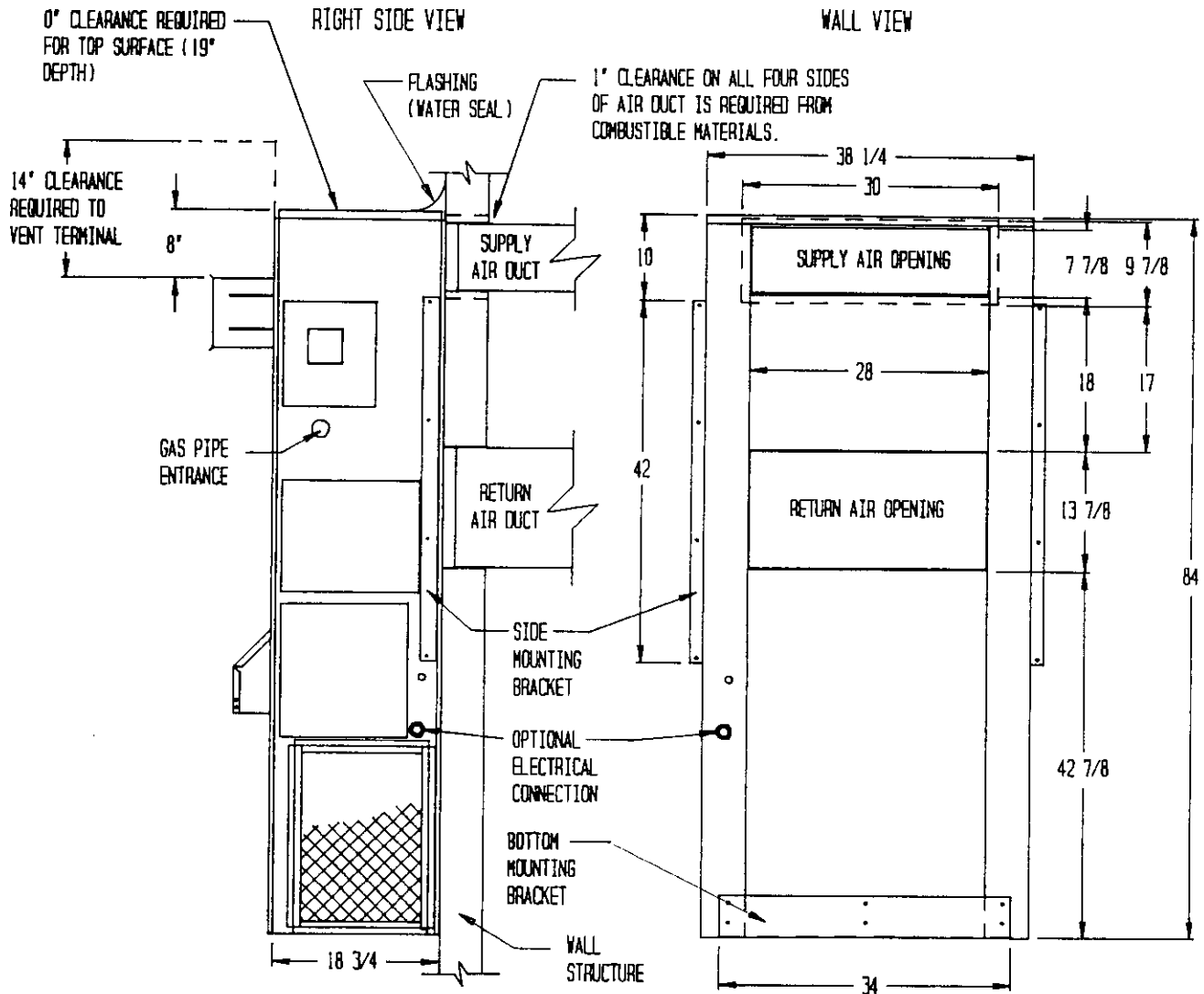

MOUNTING INSTRUCTIONS

1. These units are secured by wall mounting brackets which secure the unit to the outside wall surface at both sides and at the bottom.
2. The unit itself is suitable for "0" inch clearance, but the supply air duct flange and the first few feet of supply air duct require 1 inch clearance to combustible material. If combustible, use 30"x10" dimensions for sizing of wall opening, if non-combustible, use 28"x8" dimensions.
3. After the wall opening positions have been selected, lay out the position for the bottom and side brackets. Fasten the brackets securely to the wall (type of fasteners will depend on wall construction).
4. Be sure to observe the 10" dimension when attaching the side brackets. This will assure that no screws are driven into the unit sides damaging any internal parts. One-half inch sheet metal screws are recommended.
5. For additional mounting rigidity, the return air frame or collar can be drilled and screwed or welded to the structural wall itself.
6. Maintain 30 inches minimum clearance on right side of unit for service access and adequate condenser air flow.

FIGURE 2

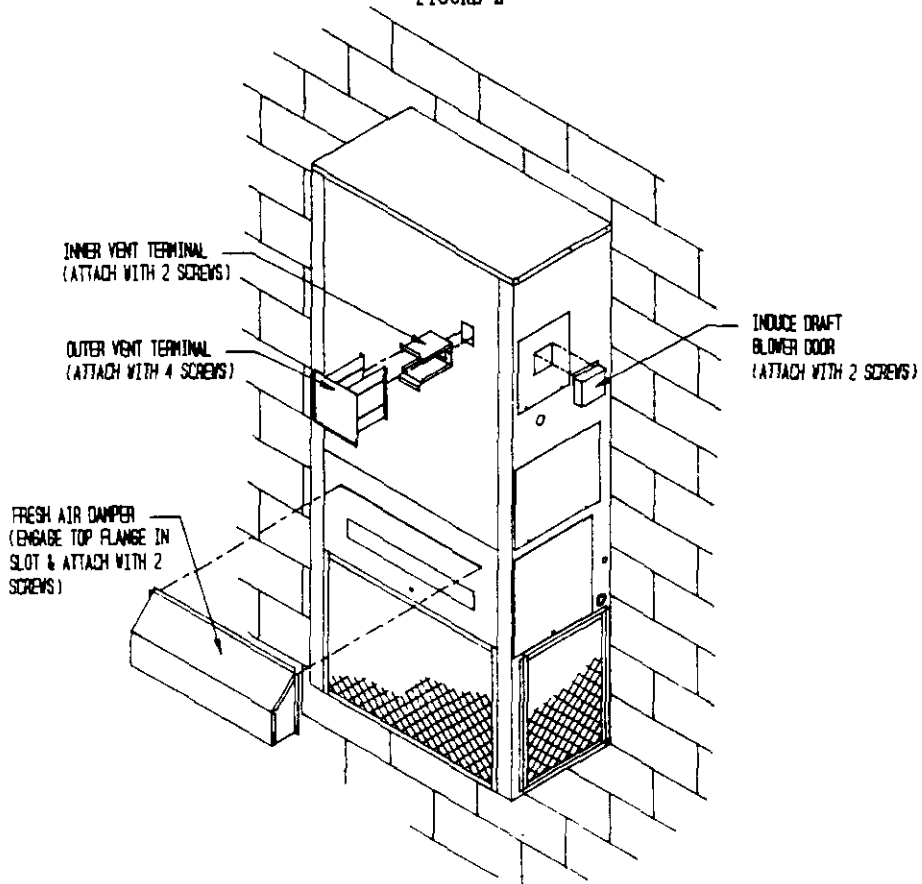
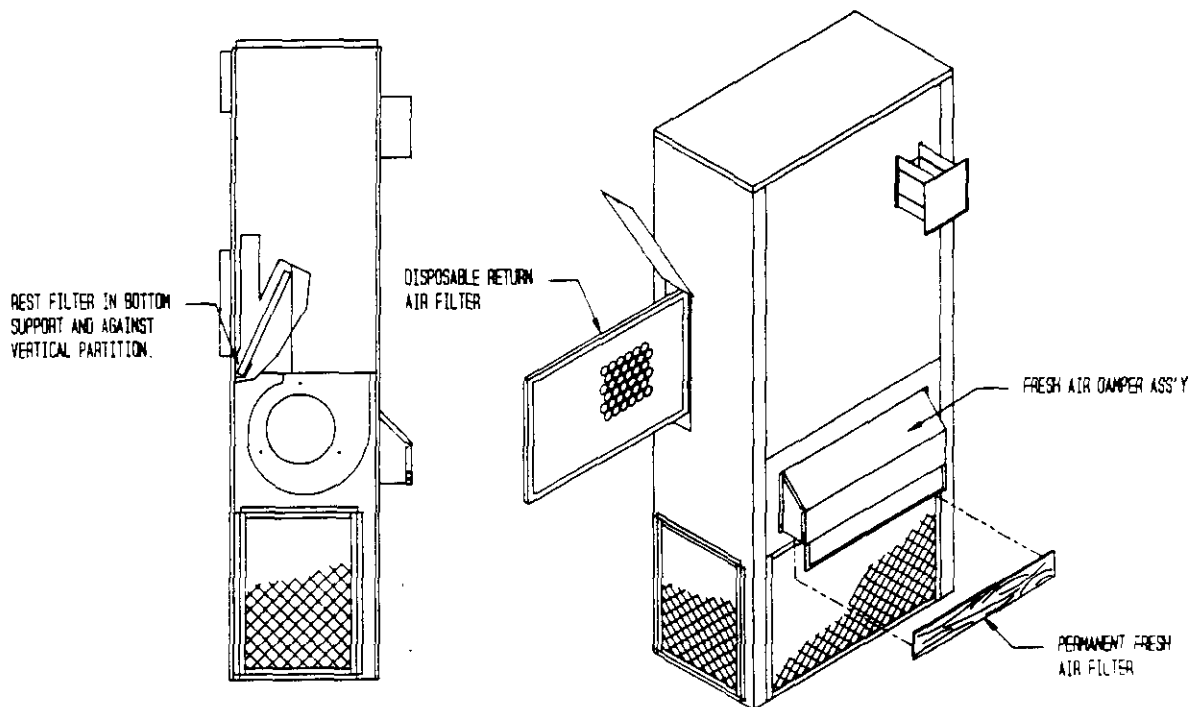

FIGURE 3



INSTALLATION

Size of unit for proposed installation should be based on heat loss calculation made according to methods of Air Conditioning Contractors of America (ACCA). The air duct should be installed in accordance with the Standards of the National Fire Protection Association for the Installation of Air Conditioning and Ventilating systems of Other Than Residence Type, NEPA No. 90A, and Residence Type Warm Air Heating and Air Conditioning Systems, NEPA No. 90B. Where local regulations are at a variance with instructions, installer should adhere to local codes.

CLEARANCES

Minimum clearances, as specified, must be maintained from adjacent structures to provide adequate fire protection, adequate combustion air, and room for service personnel. See Figure 1 for reference.

While minimum clearances are acceptable for safety reasons, they may not allow adequate air circulation around the unit for proper operation in the cooling mode. Whenever possible, it is desirable to allow additional clearance, especially around the condenser inlet and discharge openings. DO NOT install the unit in a location that will permit discharged air from the condenser to recirculate to the condenser inlet.

MINIMUM INSTALLATION CLEARANCES

Outlet Duct (From combustible materials)	1 in. First 3 ft.
Vent Terminal (From combustible materials)	14 in.
Condenser Inlet	30 in.
Filter Service	30 in.
Top (For 19 in. depth)	0 in.
Burner Service (Combustion Air Inlet)	17 in.
Combustible Base (Wood or Class A, B, or C Roof Covering Material)	0 in.

DUCT WORK

Design the duct work according to methods given by the Air Conditioning Contractors of America. When duct runs through unheated spaces, it should be insulated with a minimum of one inch of insulation. Use insulation with a vapor barrier on the outside of the insulation. Flexible joints should be used to connect the duct work to the equipment in order to keep the noise transmission to a minimum.

When a furnace is installed so that supply ducts carry air circulated by the furnace to areas outside the space containing the furnace, the return air shall also be handled by a duct(s) sealed to the furnace casing and terminating outside the space containing the furnace.

A one-inch clearance to combustible material for the first three feet of duct attached to the outlet air frame is required. See page 4 for further details.

IMPORTANT: A sheet metal sleeve connected to the supply air duct flange is required on free-blow (unducted) applications and the one inch clearance from the sleeve to combustibles is required.

FIELD INSTALLED COMPONENTS

MOUNTING BRACKETS

Two side mounting brackets are shipped fastened to the lower back surface. A bottom support bracket is shipped in the return air chamber accessed from the back of the unit. Refer to Figure 1 for proper assembly of the mounting brackets.

VENT TERMINAL AND INDUCED DRAFT BLOWER HOOD

Both the vent terminal and induced draft blower hood are shipped in the return air chamber. Remove the two shipping screws and separate the two piece assembly. Remove the two screws that are on either side of the vent discharge opening, and then install the inner vent terminal by using the same two screws just removed. Make sure gasket is in place. Slide the outer vent terminal over the inner piece and secure with four screws (two each side). See Figure 2. Also see Figure 1 for proper clearance to the vent terminal.

VENT RESIZING INSTRUCTIONS

If this appliance is used to replace an existing furnace that is removed from a venting system also serving other appliances, the venting system is likely to be too large to properly vent the remaining appliance(s).

The following steps shall be followed with each of the appliances remaining connected to the common venting system, placed in operation one at a time while the other appliances remaining connected to the common venting system are not in operation.

1. Seal any unused openings in the common venting system.
2. Visually inspect the venting system for proper size and horizontal pitch and determine there is no blockage or restriction, leakage, corrosion, and other deficiencies which could cause an unsafe condition.
3. Insofar as is practical, close all building doors and windows and all doors between the space in which the appliances remaining connected to the common venting system are located and other spaces of the building. Turn on clothes dryers and any appliance not connected to the common venting system. Turn on any exhaust fans, such as range hoods and bathroom exhausts, so they will operate at maximum speed. Do not operate a summer exhaust fan. Close fireplace dampers.
4. Follow the lighting instructions. Place the appliance being inspected in operation. Adjust thermostat so appliance will operate continuously.
5. Test for spillage at the draft hood relief opening after 5 minutes of main burner operation. Use the flame of a match or candle, or smoke from a cigarette, cigar, or pipe.
6. After it has been determined that each appliance remaining connected to the common venting system properly vents when tested as outlined above, return doors, windows, exhaust fans, fireplace dampers and any other gas-burning appliance to their previous conditions of use.
7. If improper venting is observed during any of the above tests, the common venting system must be corrected.

VENTING TROUBLESHOOTING PROCEDURES

TABLE 2

Symptoms	Possible Causes	How To Check And/Or Correct
Downrafting through the furnace	Negative pressure within the structure caused by exhaust fan of device	Check for downdraft in vent where vent connects to unit with flame from a candle or a match, or smoke from a cigarette, cigar, or pipe.
	Location of vent terminal	Verify that vent termination is positioned with the recommended specifications stated in this manual.
	Incorrect or absent vent terminal	Verify that the vent terminal is designed for and is compatible with the venting system.
Condensation in venting system	Oversized venting system	Look for condensation in or around vent pipe joints or around flue connections at furnace. To correct this condition, design the venting system in accordance with the National Fuel Gas Code, ANSI-Z223.1-latest edition and addenda Z223.1a latest edition
	Uninsulated vent installed in an unconditioned space	Check for condensation in or around vent pipe joints. Also check around the flue connecting areas on the unit. Insulate the vent in unconditioned space to prevent the above condition.
	Running vent as a liner up an existing chimney without capping off the chimney	Check to make sure the space between the vent and the inside of the chimney has been sealed. With this space being open, it may allow too much cold air in and around the vent pipe allowing the flue products to condense causing condensation back at the unit.

FRESH AIR DAMPER ASSEMBLY

The fresh air damper assembly is shipped in the return air chamber accessed from the back of the unit. Remove the shipping screws and damper assembly. Attach the damper assembly to the blower service door as shown in Figure 2. The damper assembly includes a permanent filter that can be easily removed for cleaning (Figure 3).

The damper blade is shipped in the full open position allowing the maximum amount of fresh air at all times. If no fresh air is desired or if barometric operation (blade opens when blower starts) is desired, remove and reinsert the plastic canoe clips as shown in Figure 14.

All capacity, efficiency and cost of operation information as required for Department of Energy "Energyguide" Fact Sheets is based upon the fresh air blank-off plate (BOP-1) in place and is recommended for maximum energy efficiency. The blank-off plate is available upon request from the factory and is installed in place of the fresh air damper shipped with each unit.

FILTER

A one inch throw away filter is supplied with each unit taped to the back of the unit. This filter is installed by removing the filter service door located on the left side and sliding the filter into position, as shown in Figure 3.

FIGURE 14

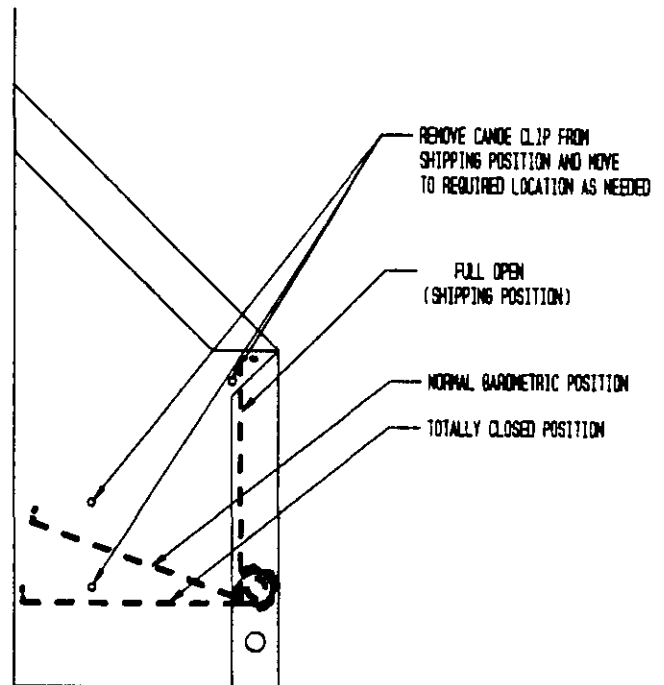

WALL MOUNTING

1. Two holes, the size of the supply and return air openings must be cut through the wall as detailed on page 4.
2. On wood-frame walls, the wall construction must be strong and rigid enough to carry the weight of the unit without transmitting any unit vibration.
3. Concrete block walls must be thoroughly inspected to insure that they are capable of carrying the weight of the installed unit.
4. Ducts through the walls must be insulated and all joints taped or sealed to prevent air or moisture entering the wall cavity.
5. Some installations may not require any return air duct. It is recommended that on this type of installation that a filter grille be located in the wall. Filters must be of sufficient size to allow a maximum velocity of 400 FPM.

WIRING - MAIN POWER

CAUTION

For your personal safety, turn off electric power at service entrance panel before making any electrical connections.

All electrical work must conform with local codes and ordinances or, in their absence, with the National Electrical Code, ANSI/NFPA 70-latest edition.

Refer to the unit rating plate for wire sizing information and maximum fuse or for (230/208V) circuit breaker size. Each outdoor unit is marked with a "Minimum Circuit Ampacity." This means that the field wiring used must be sized to carry that amount of current.

Refer to the National Electrical Code for complete current carrying capacity data on the various insulation grades of wiring material.

The electrical data lists fuse and wire sizes (60 degree C copper) for all models.

The unit rating plate lists a "Maximum Time Delay Relay Fuse" or circuit breaker ("HACR Type" for 230/208V) that is to be used with the equipment. The correct size must be used with the equipment. The correct size must be used for proper circuit protection and also to assure that there will be no nuisance tripping due to the momentary high starting current of the compressor motor.

ELECTRICAL GROUNDING

A. RECOMMENDED GROUNDING METHOD

When installed, the unit must be electrically grounded in accordance with local codes or in the absence of local codes, with the National Electrical Code, ANSI/NFPA No. 70-latest edition. Use an appropriate sized (refer to specification sheet) ground wire to a grounded connection in the service panel or a properly driven and electrically grounded ground rod.

B. ALTERNATE GROUNDING METHOD

If the recommended grounding method is impossible, permanently ground the unit from the ground connector to a grounded cold water pipe* using a separate insulated conductor of appropriate size. THIS, HOWEVER, IS NOT RECOMMENDED.

*Cold water pipe must have metal continuity to electrical ground and not be interrupted by plastic, rubber or other electrically insulating connectors (including water meter or pump) without adding a jumper wire at these connections.

NOTE: DO NOT ground to a gas supply pipe. DO NOT connect to electric power supply until appliance is permanently grounded.

THERMOSTAT

Install the thermostat in accordance with instructions packed with it. Locate the thermostat 4-1/3 feet from the floor on an inside wall away from drafts, warm air registers and floor or table lamps. Refer to unit wiring diagrams for connections.

All 24V wall thermostats have heat anticipators to compensate the thermostat for various system controls and allow the best possible cycle rates. Some anticipators are fixed and require no adjustment. However, the majority of wall thermostats have adjustable anticipators and do require adjustment to match the current rating of the control system. The nominal setting should be .60, but each installation should be checked for best operation.

Failure to adjust the anticipator lever to correspond to the actual current draw through the thermostat will cause severe short cycling if set too low and room temperature may never attain the thermostat set point, and if set too high, will cause room temperature to overshoot the set point.

GAS SUPPLY AND PIPING

GENERAL RECOMMENDATIONS

1. Be sure the gas line complies with the local codes and ordinances, or in their absence with National Fuel Gas Code, ANSI Z223.1-latest edition.
2. A sediment trap or drip leg must be installed in the supply line to the unit.
3. A ground joint union shall be installed in the gas line adjacent to and upstream from the gas valve and downstream from the manual main shut off valve.
4. A 1/8" N.P.T. plugged tapping accessible for test gauge connection shall be installed immediately upstream of the gas supply connection to the unit for the purpose of determining the supply gas pressure.
5. A manual shut-off valve shall be installed in the supply gas line external to the unit when required by local code.
6. Use steel or wrought iron pipe and fittings.
7. DO NOT thread pipe too far. Valve distortion or malfunction may result from excess pipe within the control. Use pipe joint compound resistant to the action of liquified petroleum gases on male threads only. DO NOT use Teflon tape. See Figures 4 and 5.
8. Gas pipe sizes for natural gas are shown in Tables 3 and 4. If more than one appliance is supplied from a single line size, capacity must equal or exceed the combined input to all appliances, and the branch lines feeding the individual appliances properly sized for each input.

TABLE 3
LENGTH OF STANDARD PIPE THREAD (INCHES)

Pipe Size	Effective Length Of Thread	Overall Length Of Thread
3/8	3/8	9/16
1/2	1/2	3/4
3/4	1/2-9/16	13/16
1	9/16	1

FIGURE 4

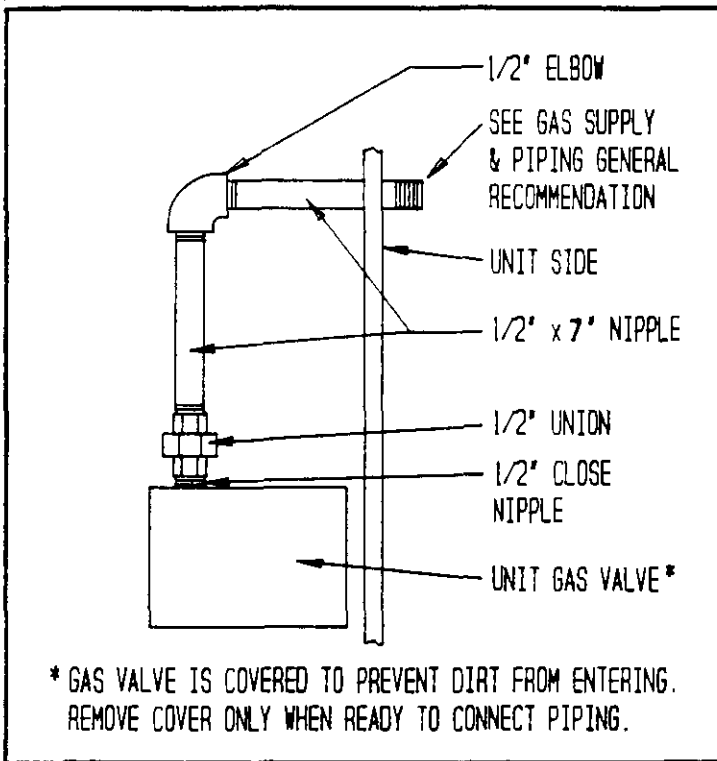
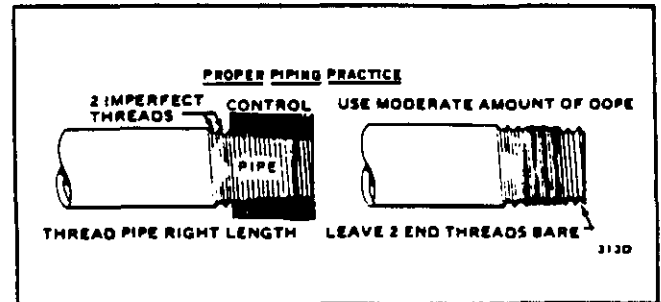

TABLE 4
GAS PIPE SIZES--NATURAL GAS

Length of Pipe, Ft.	1/2"	3/4"	1"	1-1/4"
10	132,000	278,000	520,000	1,050,000
20	92,000	190,000	350,000	730,000
30	73,000	152,000	285,000	590,000
40	63,000	130,000	245,000	500,000
50	56,000	115,000	215,000	440,000
60	50,000	105,000	195,000	400,000
70	46,000	96,000	180,000	370,000
80	43,000	90,000	170,000	350,000
100	38,000	79,000	150,000	305,000

FIGURE 5



CHECKING THE GAS PIPING

Before turning gas under pressure into piping, all openings from which gas can escape should be closed. Immediately after turning on gas, the system should be checked for leaks. This can be done by watching the 1/2 cubic foot test dial and allowing 5 minutes to show any movement, and by soaping each pipe connection and watching for bubbles. If a leak is found, make the necessary repairs immediately and repeat the above test. The unit must be isolated from the gas supply piping system by closing the manual shutoff valve on the combination gas control valve during pressure testing of the gas supply piping system at pressures up to 1/2 psig. The unit must be disconnected from supply piping and supply piping capped during any pressure testing of supply piping system at test pressures in excess of 1/2 psig.

Defective pipes or fittings should be replaced and not repaired. Never use a flame or fire in any form to locate gas leaks, use a soap solution.

After the piping and meter have been checked completely, purge the system of air. DO NOT bleed the air inside the unit. Be sure to relight all the gas pilots on other appliances that may have been extinguished because of interrupted gas supply.

DETERMINING GAS INPUT--NATURAL GAS

The following is a procedure in which to measure gas input:

1. Turn off all gas appliances other than the unit.
2. From local gas supplier, obtain the average heating value in BTU/CU FT of gas supplied to the installation site.
3. Light unit following the lighting and operating instructions label.
4. With a stop watch, measure the amount of time, in seconds, it takes to consume two (2) cubic feet of gas.
5. Use the following formula to calculate the gas input of the unit.

$$\text{Gas input rating in BTU/HR} = \frac{\text{BTU/CU FT} \times 7200}{\text{Time in seconds for two Cubic feet of gas flow}}$$

Example: Assume a time of 60 seconds for two cubic feet has been determined with a heating value of 1,000 BTU/CU FT.

$$\text{Gas input rating} = \frac{1000 \times 7200}{60}$$

$$\text{Gas input rating} = 120,000 \text{ BTU/HR}$$

6. If the input rate is not within two percent of the rated input, it may be achieved by adjusting the manifold pressure. If the specified input cannot be obtained, the unit must be reorificed.

CAUTION: For operation at elevations above 2,000, the installer must comply with the "Standard Orifice Sizing and High Altitude Derate", page 12.

DETERMINING GAS INPUT--LP GAS

The pressure regulator on the storage tank must be adjusted to maintain a manifold pressure of 10.0" W.C. on the exit side of the unit gas valve. This pressure will result in correct input when the burners are orificed properly.

GAS PRESSURE SPECIFICATIONS

This unit is equipped with fixed orifices for rated input with the following gas pressures:

TABLE 5

	Supply		Manifold
	Minimum	Maximum	
Natural @ 1,000 BTU/CU FT	4.5" WC	11.0" WC	3.5" WC
LP @ 2,550 BTU/CF FT	11.0" WC	13.0" WC	10.0" WC

The supply pressure may be measured by attaching a water column gauge to a pressure tap adjacent to and upstream from the gas valve. The manifold pressure may be measured by removing the small pipe plug located in the top of the main burner manifold, and inserting a pressure tap. Attach water column gauge to tap and ignite main burner. Small variations in the gas pressure may be made, not to exceed ± 0.1 " W.C., to achieve rated manifold pressure. This may be achieved by turning the gas valve regulator adjusting screw clockwise to increase pressure or counter-clockwise to decrease pressure. Major changes in flow rate must be made by changing the size of the main burner orifices.

LIGHTING AND SHUTDOWN INSTRUCTIONS

IMPORTANT

Should overheating occur, or the gas supply fail to shut off, shut off the manual gas valve to the unit before shutting off the electrical supply.

FIGURE 6

FOR YOUR SAFETY READ BEFORE OPERATING

WARNING: If you do not follow these instructions exactly, a fire or explosion may result causing property damage, personal injury or loss of life.

- A. This appliance is equipped with an ignition device which automatically lights the pilot. Do not try to light the pilot by hand.
- B. BEFORE OPERATING smell all around the appliance area for gas. Be sure to smell next to the floor because some gas is heavier than air and will settle on the floor.

WHAT TO DO IF YOU SMELL GAS

- Do not try to light any appliance.
- Do not touch any electric switch; do not use any phone in your building.
- Immediately call your gas supplier from a neighbor's phone. Follow the gas supplier's instructions.

- If you cannot reach your gas supplier, call the fire department.



- C. Use only your hand to push in or turn the gas control knob. Never use tools. If the knob will not push in or turn by hand, don't try to repair it, call a qualified service technician. Force or attempted repair may result in a fire or explosion.

- D. Do not use this appliance if any part has been under water. Immediately call a qualified service technician to inspect the appliance and to replace any part of the control system and any gas control which has been under water.

OPERATING INSTRUCTIONS

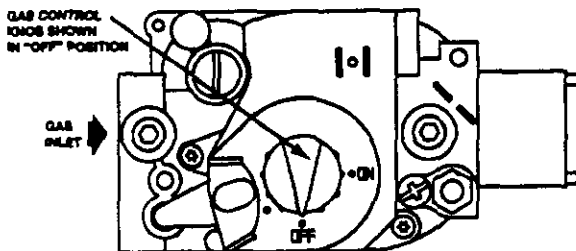
1. STOP! Read the safety information above on this label.
2. Set the thermostat to lowest setting.
3. Turn off all electric power to the appliance.
4. This appliance is equipped with an ignition device which automatically lights the pilot. Do not try to light the pilot by hand.



5. Remove control access panel.
6. Push in gas control knob slightly and turn clockwise  to "OFF".
NOTE: Knob cannot be turned to "OFF" unless knob is pushed in slightly. Do not force.
7. Wait five (5) minutes to clear out any gas. If you then smell gas, STOP! Follow "B" in the safety information above on this label. If you don't smell gas, go to next step.
8. Turn gas control knob counterclockwise  to "ON".
9. Replace control access panel.
10. Turn on all electric power to the appliance.
11. Set thermostat to desired setting.
12. If the appliance will not operate, follow the instructions "To Turn Off Gas To Appliance" and call your service technician or gas supplier.

TO TURN OFF GAS TO APPLIANCE

1. Set the thermostat to lowest setting.
2. Turn off all electric power to the appliance if service is to be performed.
3. Remove control access panel.
4. Push in gas control knob slightly and turn clockwise  to "OFF". Do not force.
5. Replace control access panel.

7981-318

SERVICE AGENCY PROCEDURES

The pilot flame can be adjusted by removing the pilot adjustment cover screw. Turn inner adjustment screw clockwise to decrease and counterclockwise to increase pilot flame. Be sure to replace cover screw after adjustment to prevent possible gas leakage.

Observe the main burners in operation. The flame should be mostly "blue" with possibly a little orange (not yellow) at the tips of the flame. The flames should be in the center of the heat exchanger compartments and not impinging on the heat exchanger surfaces themselves.

The inner cone of the flame as shown below should be approximately 1 inch to 1-1/4 inches tall from the burner ports when natural gas is used. When LP gas is used, the inner cones should be approximately 1/2 inch tall from the burner ports. If no primary air adjustment has been made after the furnace has been converted for use with LP gas, the inner cones may be lying flat on the burner ports. This condition can be corrected by decreasing the amount of primary air in the burners. Slowly close down the primary air shutters at the end of each burner until the desired inner cone height is obtained. Be sure to tighten all the air shutter set screws once the adjustment has been made.

The air shutters are factory adjusted completely open for use with natural gas. If flashback occurs, the air shutters may be closed slightly to prevent the flashback. If converted to LP gas, the air shutters must be adjusted as specified above.

Observe the fire until the blower starts (there is a normal delay period until the heat exchanger warms up). There should be no change in the size or shape of the flame. If there is any wavering or blowing of the flame on blower start-up, it is an indication of a possible leak in the heat exchanger.

FIGURE 8

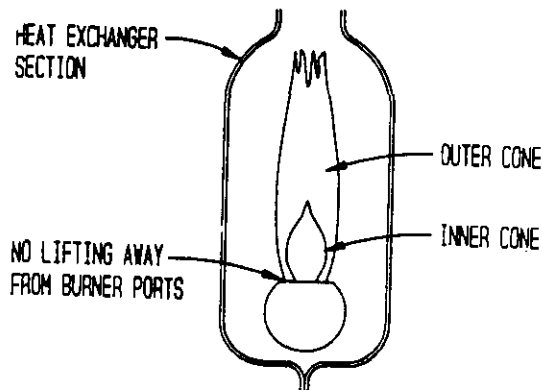

FIGURE 7
3/8 TO 1/2 INCH
(9.5 TO 12.7 MILL)
INTERMITTENT PILOT

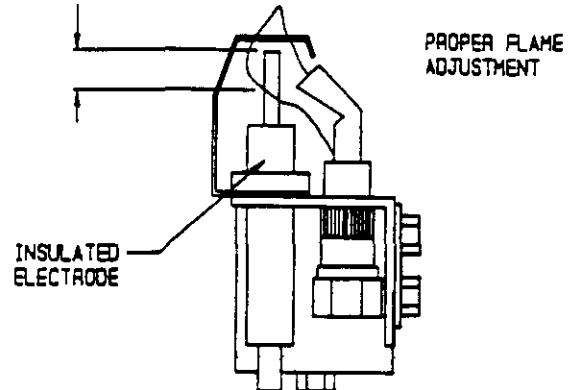
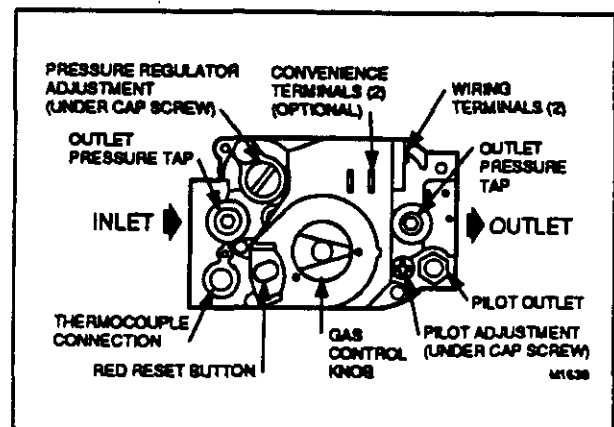

FIGURE 9
TOP VIEW OF GAS CONTROL



BURNERS/HEAT EXCHANGER/FLUE GAS PASSAGE WAYS

The burners, heat exchanger and interior flue gas passages may be inspected using a light or small mirror or an extension handle. Remove the screw securing the flue transition to the inducer assembly. Remove the inducer and collector box and flue gas baffles. Now inspect the upper chamber of the heat exchanger.

Check the exterior of the heat exchanger and the interior flue gas passages for any evidence of deterioration due to corrosion, cracking or other causes. If signs of sealing or sooting exist, remove the burners and clean the heat exchanger, as required.

INSPECTION AND CLEANING OF BURNERS AND HEAT EXCHANGERS

QUALIFIED SERVICE TECHNICIAN ONLY

1. Shut off all electricity and gas supply to the unit.
2. Remove the Vent Assembly and flue collector assembly.
2. Disconnect gas pipe at union.
4. Disconnect wires from gas valve, note connections.
5. Remove screws that secure the gas manifold and remove gas valve, manifold and burners as an assembly.
6. Clean the burners with a brush and by holding the burner vertically and tapping it against a wood block. Severe cases of lint clogging may require washing the burners in hot water.
7. Clean flue gas passages by using small brushes and a vacuum cleaner. It may be necessary to fabricate handle extensions for the brushes to reach the areas that require cleaning. Reinspect after cleaning and replace the heat exchanger if defective.
8. Reinstall parts in reverse order. Check the spark gap, 1/8 inch, between the ignitor and pilot hood.
9. Turn gas on and check for leaks.
10. Install all access panels, turn power on and check for normal operation.

MAINTENANCE INSTRUCTIONS

The unit should be inspected annually by a qualified service agency.

Routine inspection and maintenance procedures are the responsibility of the user and are outlined below.

ROUTINE MAINTENANCE

1. Air Filters . Check the condition at least monthly when the unit is in use, and replace (throwaway, fiberglass type) or clean (permanent, foam type) as necessary.
2. Lubrication Requirements . The indoor circulating air blower motor and outdoor circulating air fan motor are permanently lubricated and require no re-oiling. The combustion air blower motor should be re-oiled once a year with 3-4 drops SAE20 motor oil. **WARNING**--Turn off electrical power supply to prevent injury from moving parts or electric shock.

ROUTINE INSPECTION

1. Inspect the physical support of the unit annually to make sure it is securely fastened to the building. Also look for any obvious signs of deterioration.
2. Inspect the pilot and main burner adjustment at the beginning of each heating season. Refer to Figure 7 and Figure 8 for general guidelines. Call qualified service agency for any adjustments.
3. Inspect the vent terminal for any obvious deterioration, to make sure it is free and clear of any obstructions.

REPLACEMENT PARTS

Replacement parts for the gas/electric units are available through local distributors.

A replacement parts list manual is supplied with each unit. When ordering parts or making inquiries pertaining to any of the units covered by these instructions, it is very important to always supply the COMPLETE model number and serial number of the unit. This is necessary to assure that the correct parts (or an approved alternate part) are issued to the service agency.

SEQUENCE OF OPERATION--HEATING

On a call for heat from the thermostat, the induced draft blower relay is energized through the normally closed contacts of the air proving pressure switch. At this point the induced draft blower starts its operation. Once sufficient draft is established, the ignition module is energized through the normally open contacts of the air proving pressure switch. The pilot ignition electrode will begin to spark and the pilot valve will be energized allowing pilot gas to flow. Upon establishment of the pilot burner flame, adequate flame for burner ignition is proved to the control module allowing the main gas valve is to be energized and to discontinue ignition spark. At the same time the main valve is energized, a one minute blower delay timer is activated.

After this delay, the low speed blower relay energizes. The blower will begin operating and remain in operation until two minutes after the call for heat has been satisfied. This timing sequence guarantees blower on, blower off operation.

This unit is equipped with a flame rollout switch which is wired in series with the control circuit. This is a manual reset switch and is used for the purpose of preventing possible fire hazard in the event of a system malfunction. If this switch has opened the control circuit, there could be a possible system malfunction. Some of the conditions that might cause a rollout to occur are blockage or sooting of primary heat exchanger, over-firing of furnace due to improper main burner orifices or incorrect manifold pressure, insufficient combustion air, or installation deficiencies with respect to return air duct design or sizing.

Once the problem has been resolved, reset the switch by pressing down on the black button on top of the switch.

This unit is also equipped with an orifice plug installed in the tubing between the combustion air blower and the pressure switch. This orifice (installed in plastic tee), is designed to prevent the possibility of condensation forming in the pressure switch tubing causing nuisance problems. This orifice plug is to remain in-line at all times during operation. It is located equal distance from the combustion air blower and the pressure switch. The orifice plug is to be checked periodically to assure that it is free of dirt or foreign material causing blockage.

SEQUENCE OF OPERATION--COOLING

On a call for cooling from the room thermostat, the high speed blower relay will be energized as well as the compressor contactor. Following termination of the cooling cycle, the blower motor will continue to run for one minute.

S8600H INTERMITTENT PILOT SYSTEM TROUBLESHOOTING

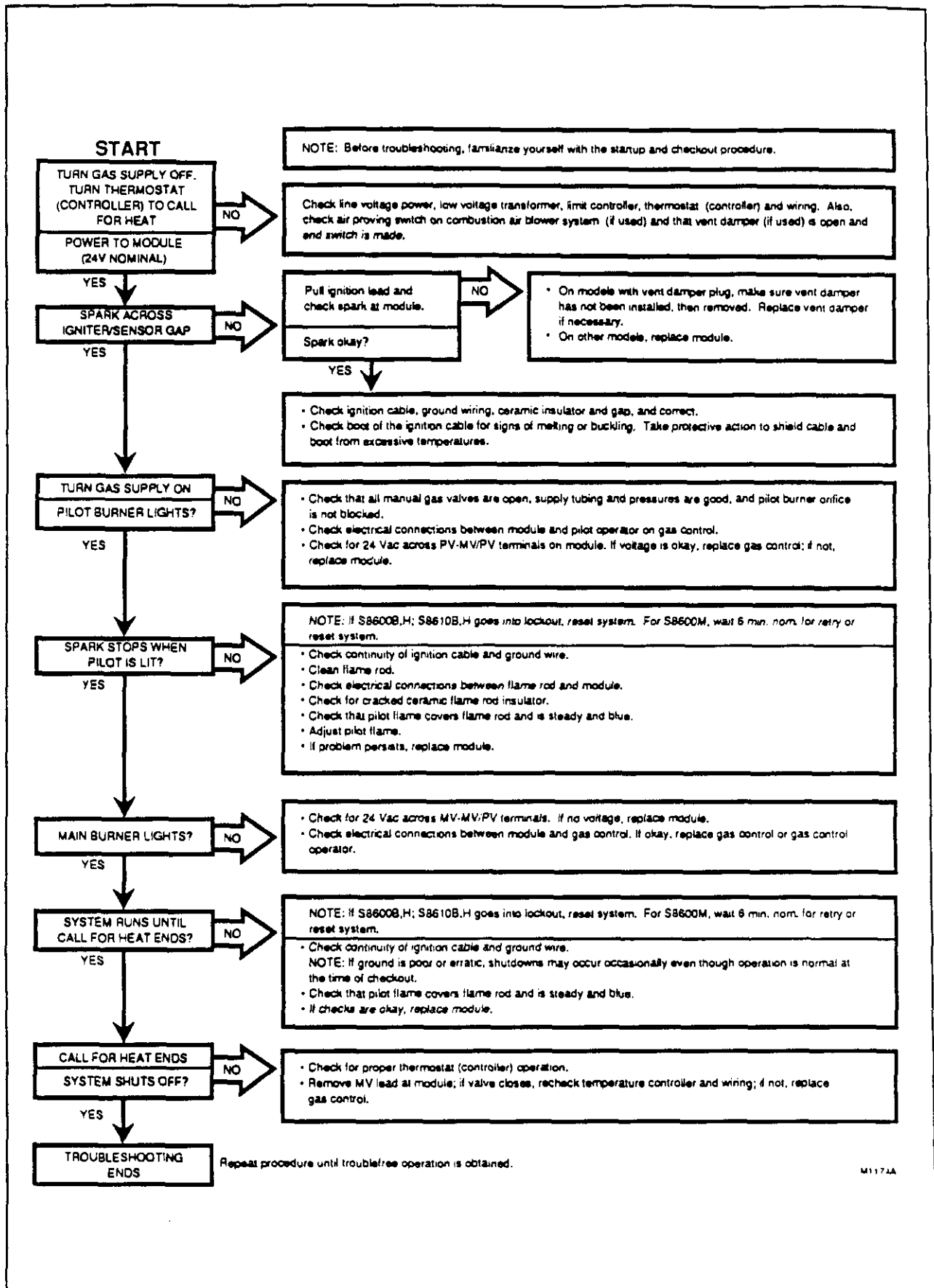

M1174A

BLOWER OPERATION

All models have two speed direct drive indoor blower motors. If supply and return ducts are connected to the unit the ducts must be of adequate size. Refer to the appropriate blower curve, see Figure 11, for maximum static pressures acceptable. Note the minimum CFM for cooling operation is 810. As produced, the circulating blower will operate on high speed during cooling and low speed during heating. If voltage and duct design permit, (see blower curves) single speed operation can be achieved as follows: Disconnect main power supply to unit. Remove the unwanted indoor motor speed tap (red low, black high) from the blower control. This wire is to be connected to terminal M1. Next install a jumper wire with multiplier between HEAT and COOL terminals and attach desired blower motor speed lead to other side of multiplier. Energize the system in cooling and heating modes and check for proper blower operation.

CAUTION

After the unit is operating with filters installed and all cabinet panels are in place, check the temperature rise through the unit to insure it is within the range specified on the unit rating plate. If it is not, adjust blower speed until the temperature rise is within specified range.

FIGURE 10

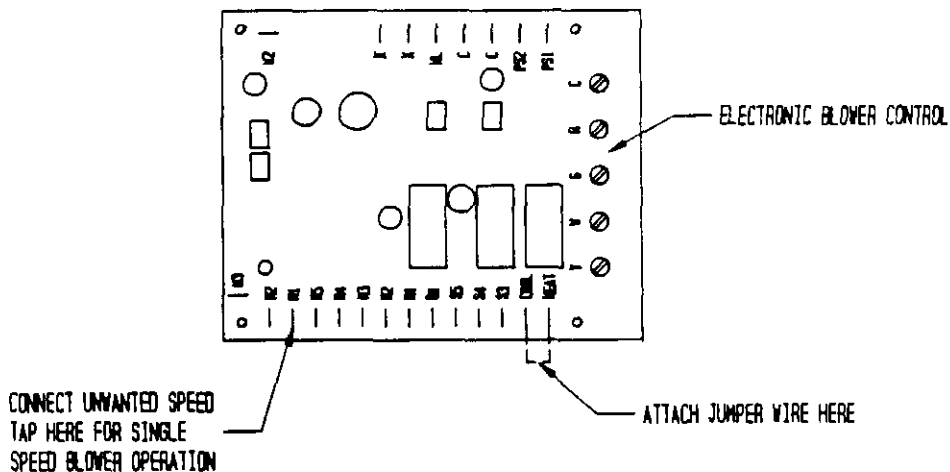

STANDARD ORIFICE SIZING AND HIGH ALTITUDE DERATE

Rating of gas utilization equipment are based on sea level operation and need not be changed for operation at elevations up to 2,000 feet. For operation at elevations above 2,000 feet, and in the absence of specific recommendations from the local authority having jurisdiction, equipment ratings shall be reduced at the rate of 4 percent for each 1,000 feet above sea level before selecting appropriately sized equipment. (Ref. ANSI Z223.1-latest edition, Par. 8.12).

These furnaces are shipped with fixed gas orifices for use with Natural Gas and sized for 1000 Btu/cubic foot gas. Make sure actual furnace gas input does not exceed furnace rating plate input. You may need to change orifices to get correct gas input. Whether you do or not depends on furnace input, your gas heat value at standard conditions and elevation. Consult your local gas supplier for gas heat value and any special derating requirements. Table 6 below gives normal orifice specifications based upon standard conditions as shown.

For propane (LP) gas operation, the furnace must be converted using authorized LP Kit sold separately.

TABLE 6
EQUIVALENT ORIFICE SIZES AT HIGH ALTITUDE
(INCLUDES 4% INPUT REDUCTION FOR EACH 1,000 FEET)

Orifice Size Chart--WAG30, WAG36, WAG40 Models--65,000 Input										
Fuel Gas Type	Gas Heat Value Btu/Cu. Ft. *	0 to 2000 Feet	2001 to 3000 Feet	3001 to 4000 Feet	4001 to 5000 Feet	5001 to 6000 Feet	6001 to 7000 Feet	7001 to 8000 Feet	8001 to 9000 Feet	9001 to 10,000 Feet
Natural	800 - 849	#31	#32	2.90mm	#33	#34	#35	#36	#37	2.60mm
	850 - 899	#32	#33	#34	#35	2.75mm	2.70mm	#37	#38	#39
	900 - 949	#33	#35	#36	2.70mm	#37	2.60mm	#38	2.50mm	2.45mm
	950 - 999	#35	2.70mm	#37	2.60mm	#38	#39	#40	#41	#42
	1000 - 1049**	#36	2.60mm	#38	#39	2.50mm	2.45mm	2.40mm	#42	2.30mm
	1050 - 1100	#37	#38	#39	#40	2.45mm	2.40mm	#42	2.30mm	#43
Propane (LP)	2500***	1.65mm	1/16"	1.55mm	1.55mm	#53	1.50mm	1.45mm	1.45mm	1.40mm

Orifice Size Chart--WAG30, WAG36, WAG40 Models--55,000 Input										
Fuel Gas Type	Gas Heat Value Btu/Cu. Ft. *	0 to 2000 Feet	2001 to 3000 Feet	3001 to 4000 Feet	4001 to 5000 Feet	5001 to 6000 Feet	6001 to 7000 Feet	7001 to 8000 Feet	8001 to 9000 Feet	9001 to 10,000 Feet
Natural	800 - 849	#35	2.70mm	#37	2.60mm	#38	#39	#40	#41	#42
	850 - 899	#36	#37	#38	#38	2.50mm	#40	2.40mm	#42	2.30mm
	900 - 949	#37	#39	2.50mm	#40	#41	2.40mm	2.35mm	2.30mm	#44
	950 - 999	#38	#40	2.45mm	2.40mm	#42	2.35mm	2.30mm	2.25mm	#44
	1000 - 1049**	#40	2.40mm	#42	2.35mm	2.30mm	#43	2.25mm	#44	2.15mm
	1050 - 1100	#41	#42	2.35mm	2.30mm	2.25mm	2.20mm	#44	2.15mm	#45
Propane (LP)	2500***	#53	1.50mm	1.45mm	1.40mm	#54	#54	1.35mm	#55	1.30mm

* At standard conditions: Sea level pressure and 60°F temperature.

** Standard factory supplied orifice size.

*** BTU/cu. ft. at 60°F temperature.

FIGURE 11
208V BLOWER CURVE

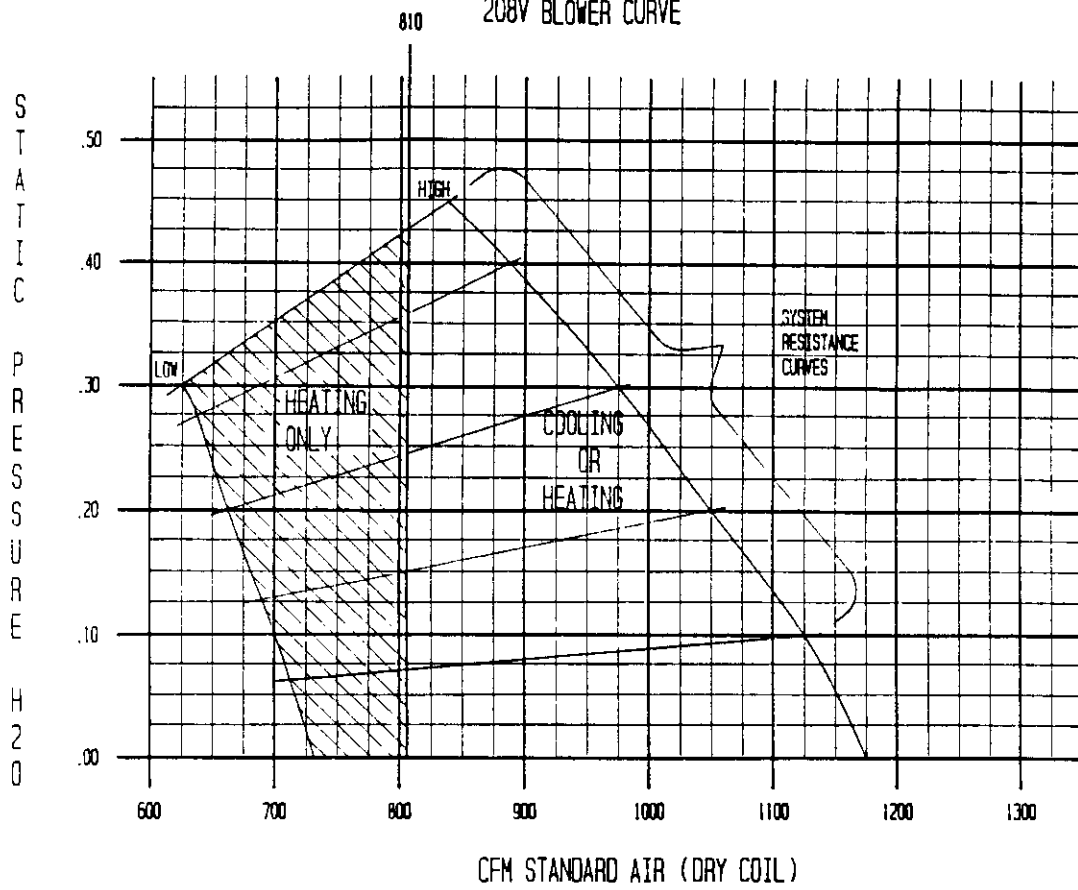

230V BLOWER CURVE

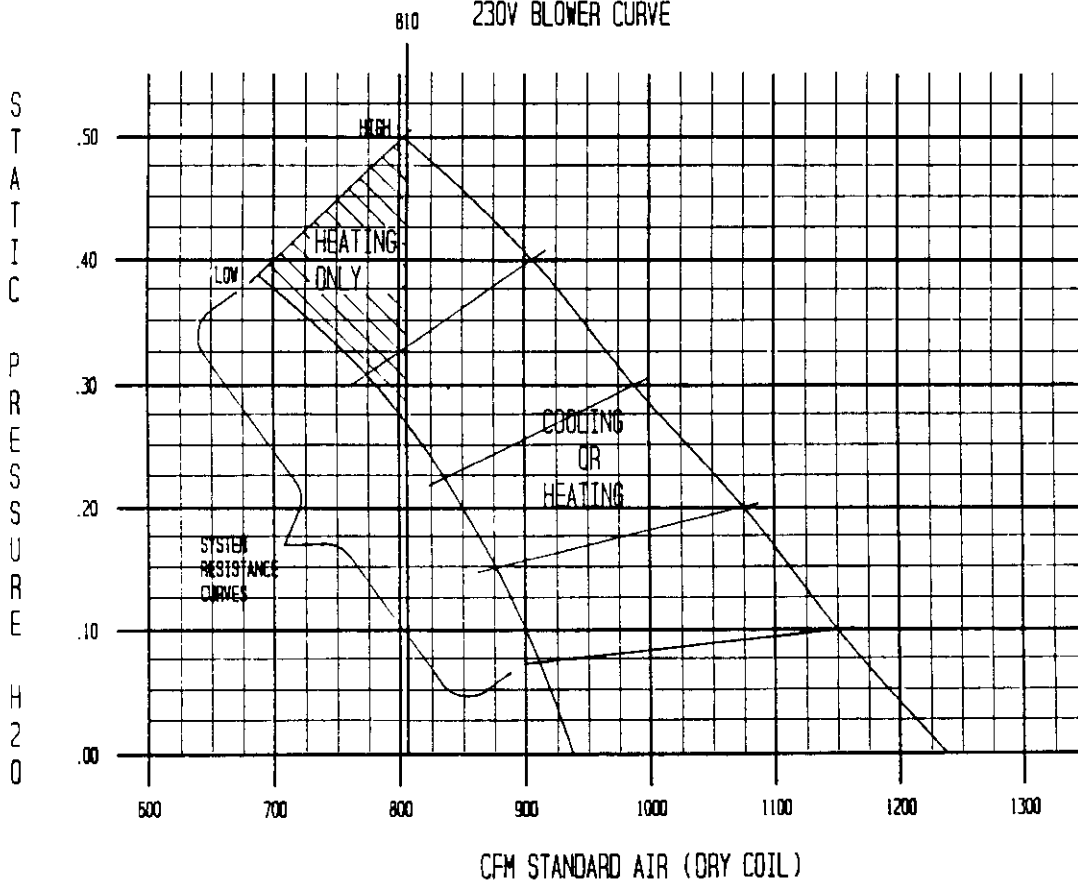

PRESSURE SERVICE PORTS

High and low pressure service ports are installed on all units so that the system operating pressures can be observed. The following chart outlines expected pressures at various indoor and outdoor temperatures.

COOLING

TABLE 8
Air Temperature Entering Outdoor Coil Degree F

Model	Return Air Temperature	Pressure	°	°	°	°	°	°	°	°	°
			75	80	85	90	95	100	105	110	115
WAG30A	75 deg. DB	Low Side	69	71	73	75	77	79	80	81	82
	62 deg. WB	High Side	208	225	242	260	277	294	311	328	345
	80 deg. DB	Low Side	74	76	78	80	82	84	85	87	88
	67 deg. WB	High Side	213	231	249	266	284	302	319	337	354
	85 deg. DB	Low Side	80	82	84	86	88	90	92	93	95
	72 deg. WB	High Side	220	239	257	276	294	312	330	348	366
WAG36A	75 deg. DB	Low Side	64	67	70	72	74	76	77	79	80
	62 deg. WB	High Side	210	223	238	253	268	284	301	318	336
	80 deg. DB	Low Side	69	72	74	77	79	81	83	85	86
	67 deg. WB	High Side	215	229	244	259	275	292	309	327	345
	85 deg. DB	Low Side	73	77	80	83	85	87	89	91	92
	72 deg. WB	High Side	222	237	252	268	285	302	320	338	357
WAG40A	75 deg. DB	Low Side	62	64	66	68	70	72	73	75	76
	62 deg. WB	High Side	211	224	237	252	267	283	301	319	339
	80 deg. DB	Low Side	65	68	71	73	75	77	78	80	81
	67 deg. WB	High Side	217	230	243	258	274	291	309	328	348
	85 deg. DB	Low Side	69	73	76	79	81	83	85	86	87
	72 deg. WB	High Side	224	237	252	267	284	302	320	340	360

REFRIGERANT CHARGE

The correct system R-22 charge is shown on the unit rating plate. Optimum unit performance will occur with a refrigerant charge resulting in a suction line temperature (6" from compressor) as shown in the following table:

TABLE 9

Model	Rated Airflow	95 Deg. F OD Temp	82 Deg. F OD Temp
WAG30A	1000	50-52	66-68
WAG36A	1000	49-51	66-68
WAG40A	1000	49-51	64-66

The above suction line temperatures are based upon 80 degree F dry bulb/67 degree wet bulb (50% R.H.) temperature and rated airflow across the evaporator during cooling cycle.

FAN BLADE SETTING DIMENSIONS

Shown in Figure 12 are the correct fan blade setting dimensions for proper air delivery across the outdoor coil.

Any service work requiring removal or adjustment in the fan and/or motor area will require that the dimensions below be checked and blade adjusted in or out on the motor shaft accordingly.

FIGURE 12

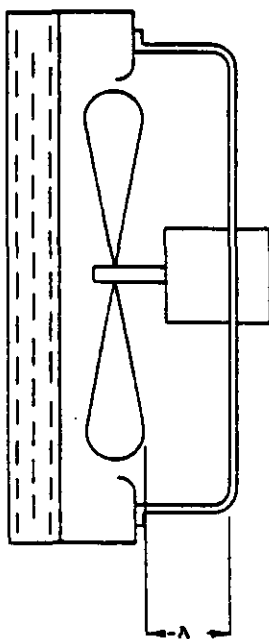

Model	Dim. A
WAG30A	1
WAG36A	1/2
WAG40A	1/2

CONVERSION OF GAS INPUT BTUH

All WAG series units are produced with maximum Btuh input (65,000 Btuh) orifices installed. To field convert to 55,000 Btuh input, a change to main burner orifices is required.

NOTE: No change to air orifices is necessary. A set of low input orifices is shipped with every unit. They will be found packaged in a cloth bag behind the burner door. Refer to the unit rating plate to confirm the proper orifice size. Proper installation of the orifices is detailed as follows:

- A. Shut off electrical supply to the unit.
- B. Shut off gas supply to the unit.
- C. Remove burner access panel.
- D. Disconnect gas valve from gas supply piping.
- E. Disconnect four wires from the gas valve, making note as to which wire came off of each terminal.
- F. Disconnect orange ignition wire from ignition module.
- G. Remove screw securing pilot assembly to burner bracket and then remove the four screws securing the manifold to the burner brackets.
- H. Remove the manifold assembly so that orifices are now accessible and remove orifices.
- I. Apply a modest amount of pipe compound to the new orifices and screw them into the manifold.
- J. To assemble burner reverse steps A through G.

LO-NOx BURNER ASSEMBLY X SUFFIX MODELS ONLY

(X) suffix models comply with South Coast Air Quality Management District Rule 1111 and Bay Area Air Quality Management District Regulation 9, Rule 4 for nitrous oxide emission levels. All (X) suffix model components are identical to (C) suffix components except for the burner assembly detailed below.

FIGURE 13

<p>CAUTION</p> <p>"X" suffix low NOx models not approved for LP gas conversion</p>

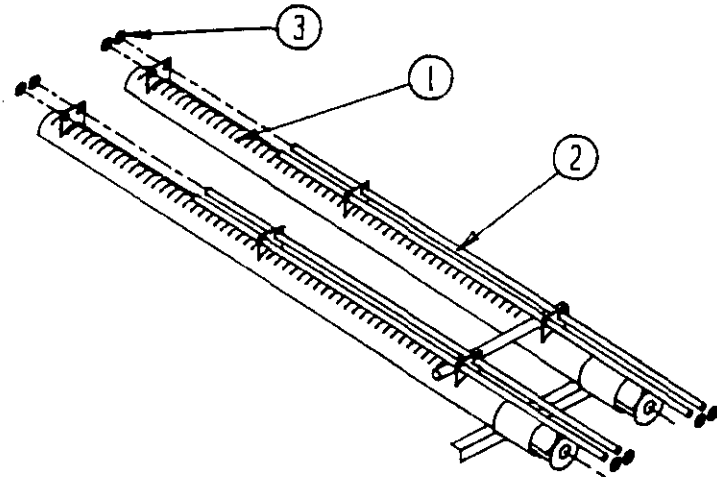
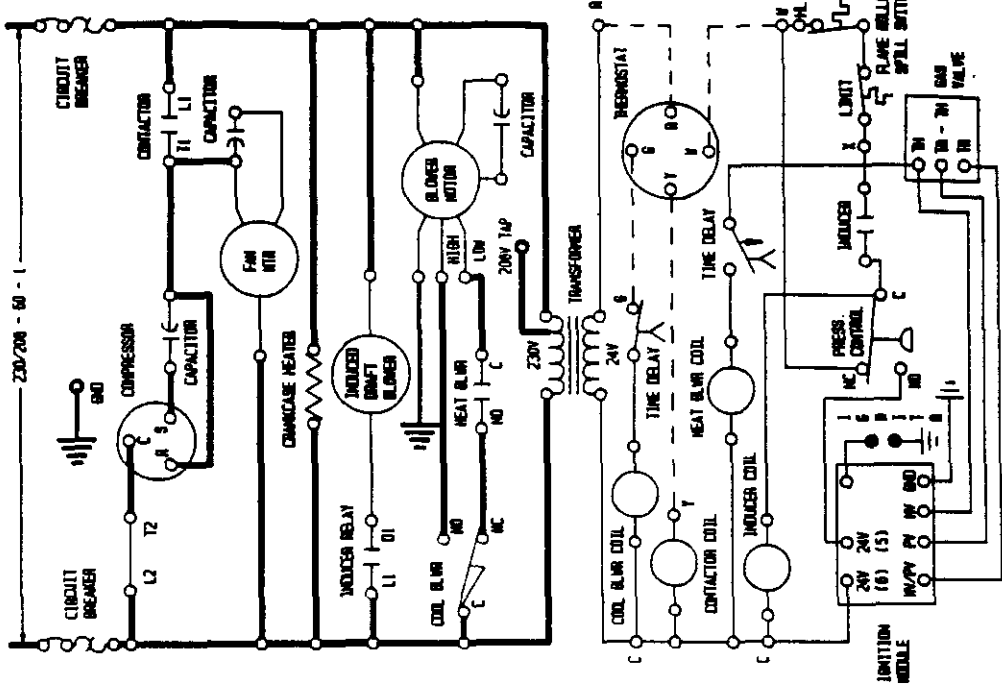

TABLE 10

Item No.	Part No.	Description	WAG30A-A54X	WAG36A-A54X	WAG36A-B54X	WAG36A-C54X	WAG40A-A54X	WAG40A-B54X	WAG40A-A54X
	901-0073	Burner Assembly (Complete)	X	X	X	X	X	X	X
1	163-025	Burner (2 Cell) Weld Assembly	X	X	X	X	X	X	X
2	2200-018	Stainless Steel Rods	(4)	(4)	(4)	(4)	(4)	(4)	(4)
3	1012-310	Stainless Steel Tinnerman	(8)	(8)	(8)	(8)	(8)	(8)	(8)

LADDER DIAGRAM



IF ANY OF THE ORIGINAL WIRE AS SUPPLIED WITH THE APPLIANCE MUST BE REPLACED, IT MUST BE REPLACED WITH WIRING MATERIAL HAVING A TEMPERATURE RATING OF AT LEAST 105° C. EXCEPT THE IGNITION CABLE WHICH IS 250° C. HIGH VOLTAGE CABLE.

4085-110 6

CONNECTION DIAGRAM

DANGER: ELECTRICAL SHOCK HAZARD.
DISCONNECT POWER BEFORE SERVICING

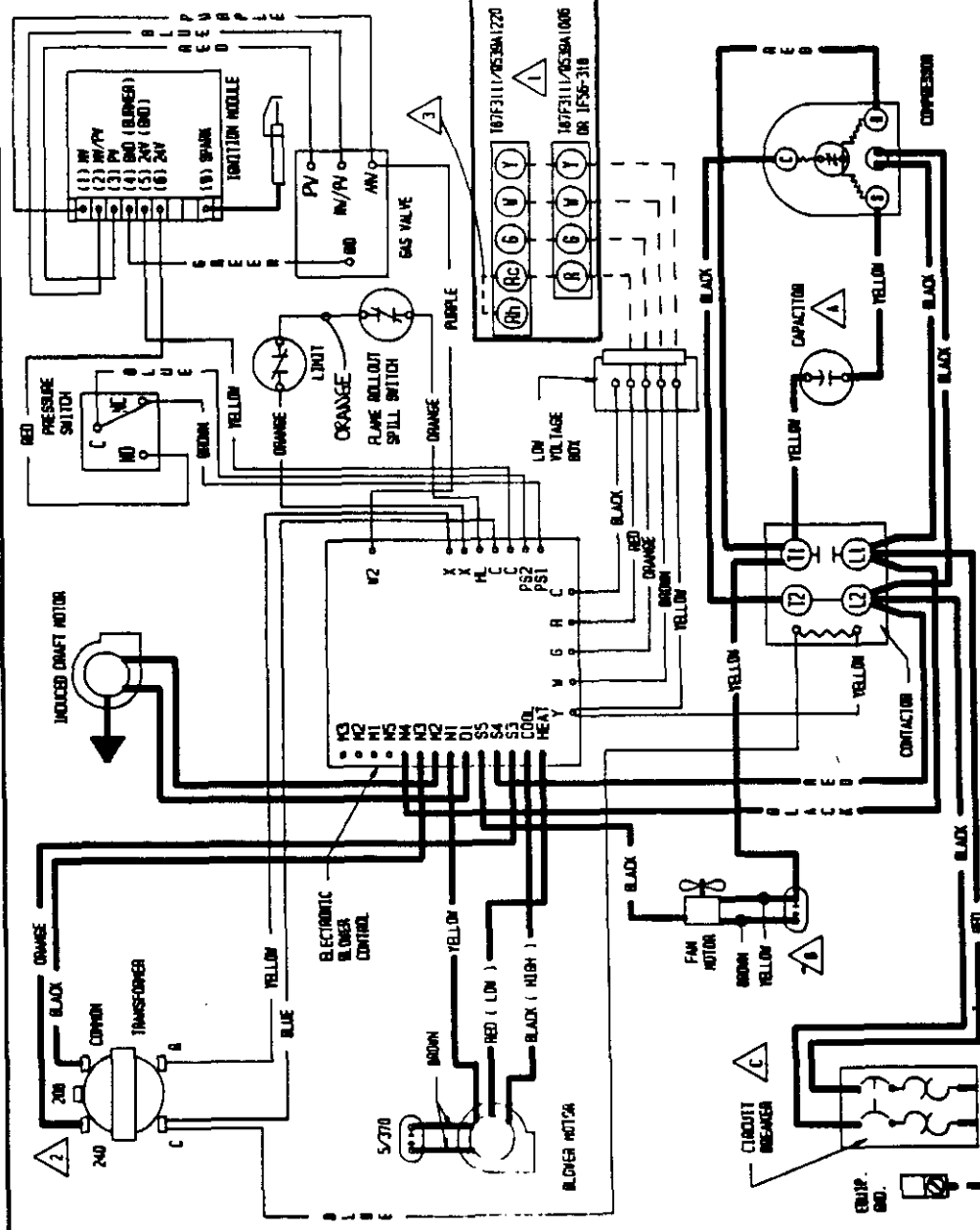

WIRE COLOR	FIELD WIRING	FACTORY WIRING
RED	---	---
ORANGE	---	---
YELLOW	---	---
BLACK	---	---

MODEL	MIN CAPACITOR	FAN CAPACITOR	CIRCUIT BREAKER
10/770-150	35/20	20/10	5A
10/770-150E	40/20	10/70	5A
10/770-150E	40/20	10/70	5A

USE COPPER OR ALUMINUM WIRE

- 1 SET HEAT ANTICIPATOR AT 5 A
- 2 FOR 200V OPERATION MOVE THIS WIRE TO 200V TRANSFORMER TAP
- 3 RED JUMPER IN - ON

LADDER DIAGRAM

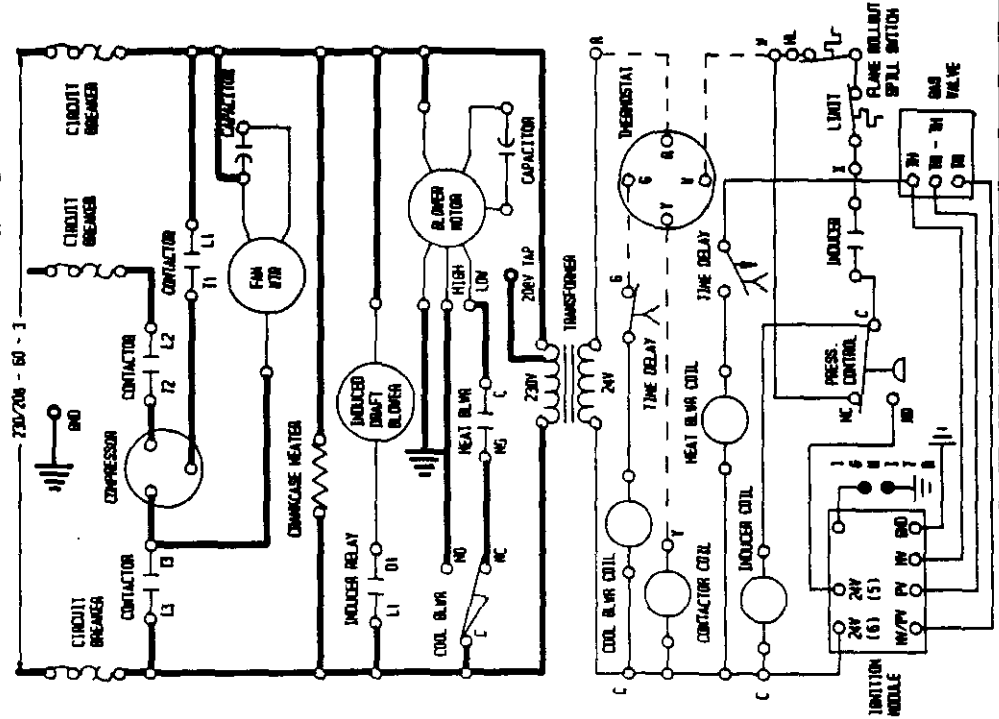

IF ANY OF THE ORIGINAL WIRE AS SUPPLIED WITH THE APPLIANCE MUST BE REPLACED, IT MUST BE REPLACED WITH WIRING MATERIAL HAVING A TEMPERATURE RATING OF AT LEAST 105° C. EXCEPT THE IGNITION CABLE WHICH IS 250° C. HIGH VOLTAGE CABLE.

4085-210 G

DANGER: ELECTRICAL SHOCK HAZARD.
DISCONNECT POWER BEFORE SERVICING

CONNECTION DIAGRAM

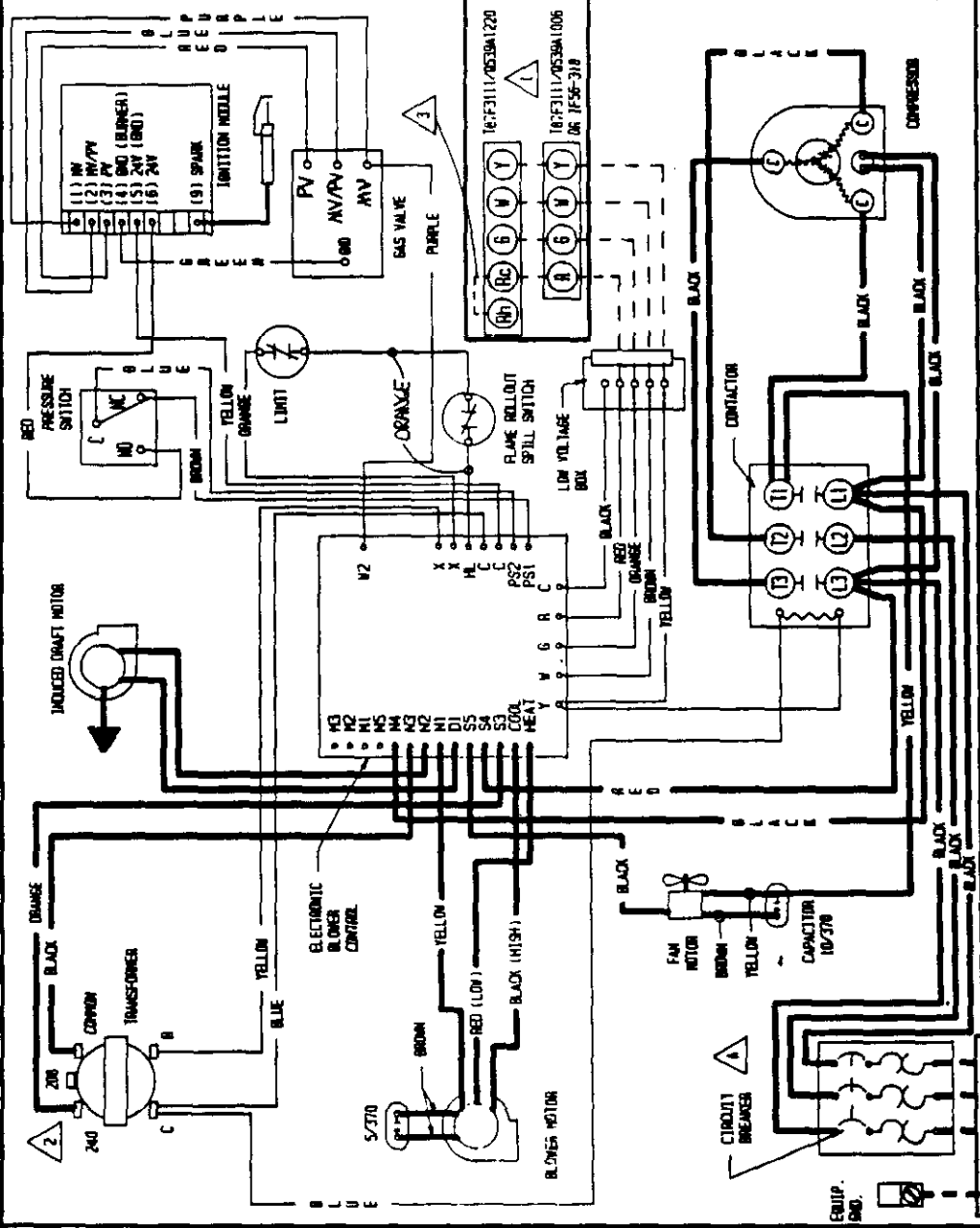

3. ADD JUMPER AS SHOWN

MODEL	FACTORY WIRING	FIELD WIRING
16:7F311/053M1220	---	---
16:7F311/053M1006 OR 16:7F311/053M1220	---	---

USE COPPER OR ALUMINUM WIRE

1. SET HEAT ANTICIPATOR AT 6.4

2. FOR 200V OPERATION MOVE THIS WIRE TO 200V TRANSFORMER TAP

CONNECTION DIAGRAM
DANGER: ELECTRICAL SHOCK HAZARD.
DISCONNECT POWER BEFORE SERVICING

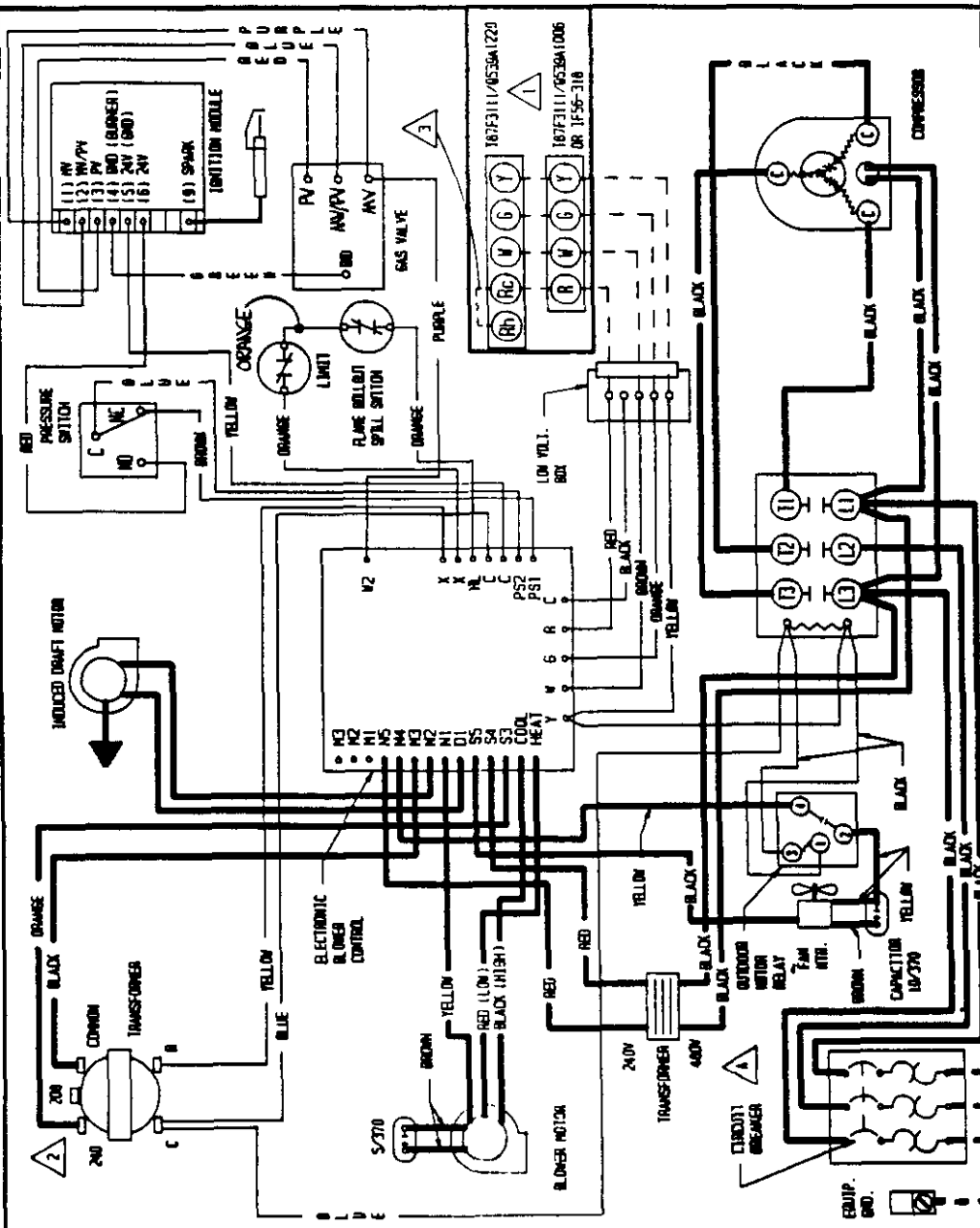

MODEL	FACTORY WIRING	FIELD WIRING
W4851-C54	---	---
W4851-C54C	---	---

MODEL	CIRCUIT BREAKER
W4851-C54	1.5A
W4851-C54C	2.0A

USE COPPER OR ALUMINUM WIRE

SET HEAT ANTICIPATOR AT 1.5 A
 FOR 200V OPERATION MORE THIS WIRE TO 200V TRANSFORMER TAP

LADDER DIAGRAM

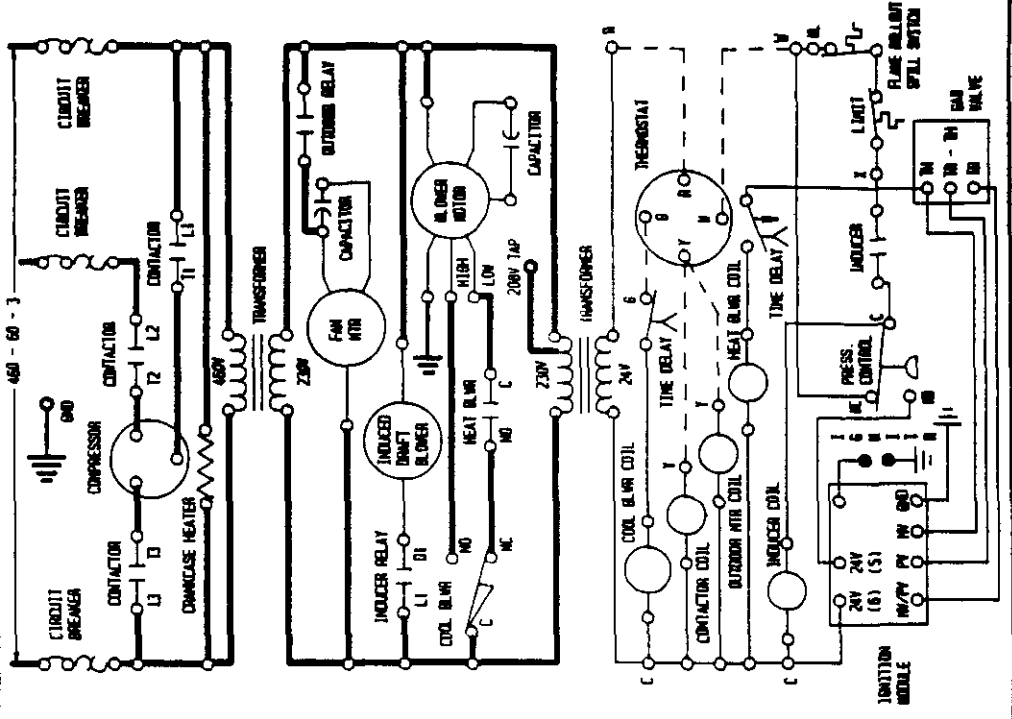

IF ANY OF THE ORIGINAL WIRE AS SUPPLIED WITH THE APPLIANCE MUST BE REPLACED, IT MUST BE REPLACED WITH WIRING MATERIAL HAVING A TEMPERATURE RATING OF AT LEAST 105° C. EXCEPT THE IGNITION CABLE WHICH IS 250° C. HIGH VOLTAGE CABLE.