

INSTALLATION INSTRUCTIONS

MODELS:

HI-BOY

IH60D36B
IH85D48B
IH115D48B

LO-BOY

IL85D42A
IL115D48A
IL145D60A

COUNTERFLOW

IC60D36A
IC85D42A
IC115D48A

**HIGH ECONOMY
GAS FURNACES**

COPYRIGHT SEPTEMBER, 1989
BARD MANUFACTURING COMPANY
BRYAN, OHIO

TABLE OF CONTENTS

I.	Application	1
II.	High Altitude Application	1
III.	Transportation Damage	1
IV.	Locating the Furnace	1
V.	Duct Work	3
VI.	Combustion and Ventilation Air	3
VII.	Gas Supply and Piping	5
	1. General Recommendations	5
	2. Checking the Gas Piping	6
	3. Determining Gas Input--Natural Gas	6
	4. Determining Gas Input--LP Gas	7
	5. Gas Pressure Specifications	7
	6. Orifice Sizing	7
VIII.	Wiring	8
	1. Electrical Power Supply	8
	2. Electrical Grounding	8
	A. Recommended Grounding Method	8
	B. Alternate Grounding Method	9
	3. Field Installed Equipment	9
IX.	Venting Applications	10
	1. Marginal Existing Vent Systems	10
	A. Undersized Vents	10
	B. Oversized Vents	10
	C. Other Factors Resulting in Condensation	10
	D. Presale Inspection	10
	2. Vent Inspection Check List	10
	3. Suggested Vent Remedies	11
	4. Vent Resizing Instructions	12
	5. Venting Troubleshooting Procedures	13
	6. Vertical Venting Instructions	14
	A. General Instructions.	14
	7. Sidewall Venting Instructions	17
	A. Approved Sidewall Vent Components	17
	B. Approved Sealants	17
	C. General Instructions	17
	D. Location of Vent Terminal	18
	E. Assembly of Vent	20
	F. Vent Passage Through A Combustible Wall	20
X.	Thermostat	21
XI.	Blower Operation.	21
	1. Blower Speed Adjustment	21
XII.	Filters	22
	1. Filter Locations--Removal and Replacement Procedures-- Hi-Boy Models	22
	2. Alternate Bottom Filter Location	24
	3. Filter Locations--Counterflow Models	25
	4. Filter Locations--Lo-Boy Models	26
XIII.	Sequence of Operation	26
XIV.	Maintenance Instructions	27
XV.	Replacement Parts	27
XVI.	Service Agency Procedures	27
XVII.	Wiring Diagrams	29
XVIII.	S8600H Intermittent Pilot System Troubleshooting	32
XIX.	Common Venting Requirements	33

FIGURES AND TABLES

Figure 1	4
Figure 2	4
Figure 3	5
Figure 4	6
Figure 5	16
Figure 6	16
Figure 7	16
Figure 8	16
Figure 9	18
Figure 10	19
Figure 11	20
Figure 12	20
Figure 13	23
Figure 14	23
Figure 15	24
Figure 16	25
Figure 17	25
Figure 18	26
Figure 19	26
Figure 20	28
Figure 21	28
Figure 22	28
Figure 23	34
Figure 24	34
Figure 25	34
Figure 26	34
Figure 27	35
Figure 28	35

Table 1	2
Table 2	6
Table 3	6
Table 4	7
Table 4A	8
Table 4B	8
Table 5	8
Table 6	13
Table 7	17
Table 8	22
Table 9	32
Table 10	32
Table 11	33

I. APPLICATION

This is a forced air gas furnace for indoor installation in building constructed on site. The furnace installation must conform with local building codes and ordinances or, in their absence with the National Fuel Gas Code, ANSI Z223.1-latest edition, and the National Electrical Code ANSI/NEPA 70-latest edition. It is the personal responsibility and obligation of the purchaser to contract a qualified installer to assure that installation is adequate and is in conformance with governing codes and ordinances.

II. HIGH ALTITUDE APPLICATIONS

Ratings of gas utilization equipment are based on sea level operation and need not be changed for operation at elevations up to 2,000 feet. For operation at elevations above 2,000 feet and, in the absence of specific recommendations from the local authority having jurisdiction, equipment ratings shall be reduced at the rate of 4 percent for each 1,000 feet above sea level before selecting appropriately sized equipment. (Ref. ANSI Z223.1-latest edition, Par. 8.12). See Table 4A.

III. TRANSPORTATION DAMAGE

All units are packed securely in shipping container. All units should be carefully inspected upon arrival for damage. In the event of damage, the consignee should:

1. Note on delivery receipt of any damage to container.
2. Notify carrier promptly, and request an inspection.
3. In case of concealed damage, the carrier must be notified as soon as possible within 15 days after delivery.
4. Claims for any damage, apparent or concealed, should be filed with the carrier, using the following supporting documents:
 - A. Original Bill of Lading, certified copy, or indemnity bond.
 - B. Original paid freight bill of indemnity in lieu thereof.
 - C. Original invoice or certified copy thereof showing trade and other discounts or deductions.
 - D. Copy of the inspection report issued by carrier's representative at the time damage is reported to carrier.

The carrier is responsible for making prompt inspection of damage and for a thorough investigation of each claim.

IV. LOCATING THE FURNACE

When selecting a location for the furnace, observe the following points:

1. The furnace should be set on a level floor. If the floor may become damp or wet at times, the furnace should be supported above the floor using a concrete base, bricks, patio blocks, etc., making sure adequate support is available for the furnace. Counterflow furnaces require use of combustible floor base if installed on combustible surface. The combustible floor base is not part of the furnace and must be ordered separately. Furnaces approved for installation on combustible flooring shall not be installed directly on carpeting, tile or other combustible material other than wood flooring.
2. The furnace should be as centralized as practical with respect to the air distribution system.

3. Provisions must be made for venting combustion products outdoors through an individual venting system.
4. Provide at least the minimum clearances specified in Table 1 for fire protection, proper operation and service access. These clearances must be permanently maintained. The combustion and ventilating air openings in front of the furnace must never be obstructed.
5. Minimum service clearances must take precedence over fire protection clearances (minimum installation clearances).
6. All models are approved for a utility room or closet installation.
7. A gas-fired furnace installed in a residential garage must be installed so that the burners and ignition source are located not less than 18 inches above the floor, and the furnace must be located or protected to avoid physical damage by vehicles.

TABLE 1
MINIMUM CLEARANCES (INCHES)

Model	Minimum Installation Clearances							Minimum Service Clearance		
	Top	Front	Vent	Back	Left Side	Right Side	Floor	Front	Sides	Back
IL85D42A Lo-Boy	1	6	6*	0	0	1+	C	24	18 (1)	24
IL115D48A Lo-Boy	1	6	6*	0	0	0	C	24	18 (1)	24
IL145D60A Lo-Boy	1	6	6*	0	0	0	C	24	18 (1)	24
IH60D36B Hi-Boy	1	6	6*	0	0	4+	C	24	0	0
IH85D48B Hi-Boy	1	6	6*	0	0	1+	C	24	0	0
IH115D48B Hi-Boy	1	6	6*	0	0	0	C	24	0	0
IC60D36A Counterflow	1	6	6*	0	0	4+	NC	24	0	0
IC85D42A Counterflow	1	6	6*	0	0	1+	NC	24	0	0
IC115D48A Counterflow	1	6	6*	0	0	0	NC	24	0	0

- (1) Minimum clearance at least one side for access to rear of furnace.
- * Clearance may be 1 inch when Type B-1 vent is used.
- + Clearance may be 0 inch when Type B-1 vent is used.
Clearance may be 2" when approved side wall vent material is used.
- C Floor may be combustible material.
- NC Floor must be non-combustible. Can be installed on combustible flooring only when installed on special base available from factory.

V. DUCT WORK

The air distribution system should be designed and installed in conformance with Manuals J or N published by Air Conditioning Contractors of America (ACCA), as set forth in their Manual D.

CAUTION

When a furnace is installed so that supply ducts carry air circulated by the furnace to areas outside the space containing the furnace, the return air must also be handled by a duct(s) sealed to the furnace casing and terminating outside the space containing the furnace. This is to prevent drawing possible hazardous combustion products into the circulated air.

When the furnace is used in connection with a cooling unit*, the furnace shall be installed parallel with or on the upstream side of the cooling unit to avoid condensation in the heating element. With a parallel flow arrangement, the dampers or other means used to control flow of air shall be adequate to prevent chilled air from entering the furnace, and if manually operated, must be equipped with means to prevent operation of either unit, unless the damper is in the full heat or cool position.

*A cooling unit is an air conditioning coil, heat pump coil or chilled water coil.

VI. COMBUSTION AND VENTILATION AIR

The furnace and furnace room must have an adequate supply of air for safe combustion and ventilation. The provisions necessary to assure an adequate air supply will vary depending upon differences in the tightness of house construction and in the location of the furnace. Methods of providing air from some typical situations are described below. Consult local codes and ordinances for requirements applicable to your specific furnace installation conditions and comply with them. In the absence of local codes and ordinances, comply with the National Fuel Gas Code, ANSI Z223.1-latest edition.

EXAMPLE 1--FURNACE LOCATED IN AN UNCONFINED SPACE

- A. If the furnace is located in a basement or other large, open area of a conventionally built house (loose construction), the air that leaks into the building normally will provide an adequate air supply.

EXAMPLE 2--FURNACE LOCATED IN A CONFINED SPACE

- A. When the furnace is in a closet or utility room, install two open grilles in a wall or door opening to the rest of the house. Each grille must have a free area of at least one square inch for each 1000 Btuh of total input rating of all gas appliances in the confined space. Refer to Figure 1. The grilles must communicate with other open areas having adequate air infiltration from outdoors.
- B. If the building is tightly constructed, not enough outside air may enter for safe combustion. Install a fresh air duct from a point near the burners to the outside or to a ventilated attic or crawl space. Refer to Figure 2. This duct must have a free area of at least one square inch for each 4000 Btuh of total input of all gas appliances in the space. The minimum dimension of a rectangular duct must not be less than three inches.

CAUTION

When a furnace is installed in a closet or utility room, never use this room as a return air plenum.

FIGURE 1
FURNACE LOCATED IN CONFINED SPACE

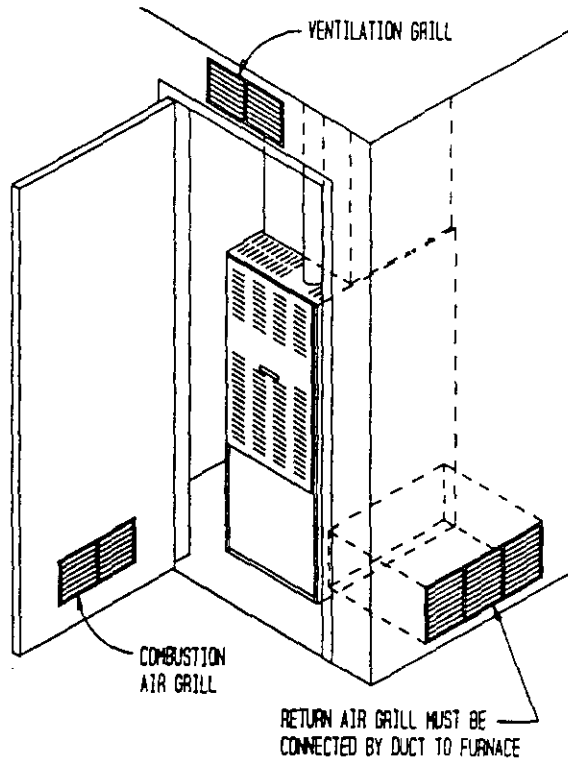
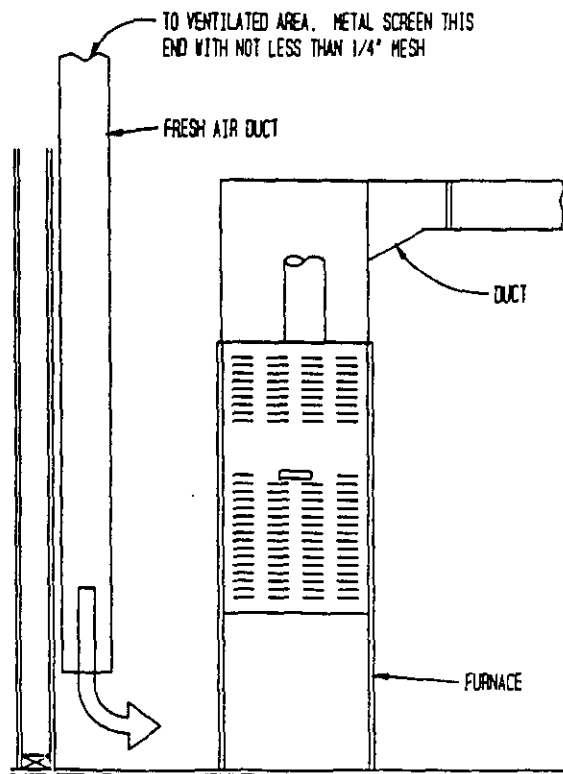

FIGURE 2
FRESH AIR DUCT FOR TIGHTLY SEALED BUILDING



VII. GAS SUPPLY AND PIPING

GENERAL RECOMMENDATIONS

1. Be sure the gas line complies with the local codes and ordinances, or in their absence with National Fuel Gas Code, ANSI Z223.1-latest edition.
2. A sediment trap or drip leg must be installed in the supply line to the furnace.
3. A ground joint union shall be installed in the gas line adjacent to and upstream from the gas valve and downstream from the manual shut off valve.
4. An 1/8" N.P.T. plugged tapping accessible for test gauge connection shall be installed immediately upstream of the gas supply connection to the furnace for the purpose of determining the supply gas pressure.
5. A manual shut-off valve shall be installed in the supply gas line external to the furnace when required by local code. See Figure 3.

FIGURE 3
TYPICAL GAS PIPING

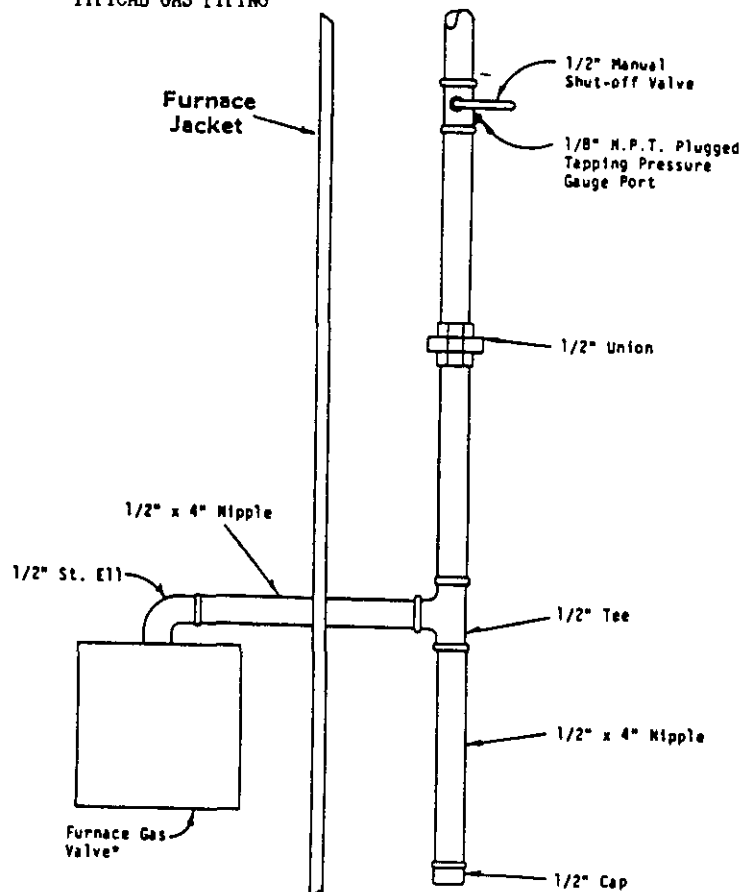

*Gas valve is covered to prevent dirt from entering.
Remove cover only when ready to connect piping.

6. Use steel or wrought iron pipe and fittings.
7. DO NOT thread pipe too far. Valve distortion or malfunction may result from excess pipe within the control. Use pipe joint compound resistant to the action of liquified petroleum gases on male threads only. DO NOT use Teflon tape. See Table 2 and Figure 4.

FIGURE 4

TABLE 2
LENGTH OF STANDARD PIPE THREADS (inches)

Pipe Size	Effective Length of Thread	Overall Length of Thread
3/8	3/8	9/16
1/2	1/2	3/4
3/4	1/2-9/16	13/16
1	9/16	1

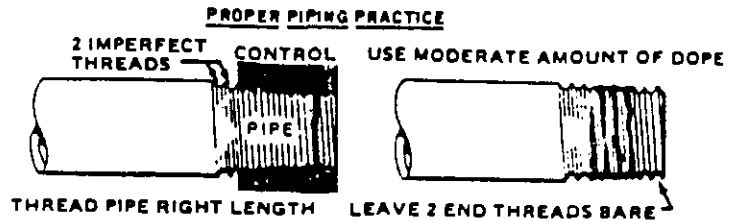

8. Refer to Table 3 for Gas Pipe Sizes for natural gas. If more than one appliance is supplied from a single line size, capacity must equal or exceed the combined input to all appliances, and the branch lines feeding the individual appliances properly sized for each input.

TABLE 3
GAS PIPE SIZES--NATURAL GAS

Length of Pipe, Ft.	Pipe Capacity--Btu Per Hour Input Pipe Size			
	1/2"	3/4"	1"	1-1/4"
10	132,000	278,000	520,000	1,050,000
20	92,000	190,000	350,000	730,000
30	73,000	152,000	285,000	590,000
40	63,000	130,000	245,000	500,000
50	56,000	115,000	215,000	440,000
60	50,000	105,000	195,000	400,000
70	46,000	96,000	180,000	370,000
80	43,000	90,000	170,000	350,000
100	38,000	79,000	150,000	305,000

CHECKING THE GAS PIPING

Before turning gas under pressure into piping, all openings from which gas can escape should be closed. Immediately after turning on gas, the system should be checked for leaks. This can be done by watching the 1/2 cubic foot test dial and allowing 5 minutes to show any movement, and by soaping each pipe connection and watching for bubbles. If a leak is found, make the necessary repairs immediately and repeat the above test. The furnace must be isolated from the gas supply piping system by closing the manual shutoff valve on the combination gas control valve during pressure testing of the gas supply piping system at pressures up to 1/2 psig. The furnace must be disconnected from supply piping and supply piping capped during any pressure testing of supply piping system at test pressures in excess of 1/2 psig.

Defective pipes or fittings should be replaced and not repaired. Never use a flame or fire in any form to locate gas leaks, use a soap solution.

After the piping and meter have been checked completely, purge the system of air. DO NOT bleed the air inside the furnace. Be sure to check and relight all the gas pilots on other appliances that may have been extinguished because of interrupted gas supply.

DETERMINING GAS INPUT--NATURAL GAS

The following is a procedure in which to measure gas input:

1. Turn off all gas appliances other than the furnace.

2. From local gas supplier, obtain the average heating value in BTU/CU FT of gas supplied to the installation site.
3. Light furnace following the lighting and operating instructions label.
4. With a stop watch, measure the amount of time, in seconds, it takes to consume two (2) cubic feet of gas.
5. Use the following formula to calculate the gas input of the furnace.

$$\text{Gas input rating in BTU/HR} = \frac{\text{BTU/CU FT} \times 7200}{\text{Time in seconds for two Cubic feet of gas flow}}$$

Example: Assume a time of 60 seconds for two cubic feet has been determined with a heating value of 1,000 BTU/CU FT.

$$\text{Gas input rating} = \frac{1000 \times 7200}{60}$$

$$\text{Gas input rating} = 120,000 \text{ BTU/HR}$$

6. If the input rate is not within two percent of the rated input, it may be achieved by adjusting the manifold pressure. If the specified input cannot be obtained, the furnace must be reorificed.

CAUTION: For operation at elevations above 2,000, the installer must comply with the "High Altitude Applications" section on Page 1.

DETERMINING GAS INPUT--LP GAS

The pressure regulator on the storage tank must be adjusted to maintain a manifold pressure of 10.0" W.C. on the exit side of the furnace gas valve. This pressure will result in correct input when the burners are orificed properly.

GAS PRESSURE SPECIFICATIONS

This furnace is equipped with fixed orifices for rated input with the following gas pressures:

TABLE 4

	Supply		
	Minimum	Maximum	Manifold
Natural @ 1,000 BTU/CU FT	4.5" WC	11.0" WC	3.5" WC
LP @ 2,550 BTU/CF FT	11.0" WC	13.0" WC	10.0" WC

The supply pressure may be measured by attaching a water column gauge to a pressure tap adjacent to and up stream from the gas valve. The manifold pressure may be measured by removing the small pipe plug located in the top of the main burner manifold, and inserting a pressure tap. Attach water column gauge to tap and ignite main burner. Small variations in the gas pressure may be made, not to exceed ± 0.1 " W.C., to achieve rated manifold pressure. This may be achieved by turning the gas valve regulator adjusting screw clockwise to increase pressure or counter-clockwise to decrease pressure. Major changes in flow rate must be made by changing the size of the main burner orifices.

ORIFICE SIZING

All high economy gas furnaces are shipped with fixed gas orifices for use with natural gas. These standard orifices are sized for elevations below 2,000 feet above sea level. For installations above 2,000 feet, refer to the "High Altitude Applications" section on Page 1 of this manual for resizing procedure and Table 4B for orifice drill size and decimal equivalents.

Standard orifice size for elevations below 2,000 feet for natural gas for all high economy furnaces is a No. 38 (.1015") drill. For use with LP gas when installed in elevations below 2,000 feet, a No. 53 (.0595") drill is to be used. NOTE: For LP gas capability, the burner must be converted to LP gas by means of an LP conversion kit that is sold separately.

TABLE 4A
EQUIVALENT ORIFICE SIZES AT HIGH ALTITUDE
(INCLUDES 4% INPUT REDUCTION FOR EACH 1,000 FEET)

Model	Gas Type	Orifice Size At Sea Level	Orifice Size Required At Other Elevations								
			2000	3000	4000	5000	6000	7000	8000	9000	10,000
All High-Economy Gas Furnaces	Nat	38	39	40	41	41	42	42	43	43	44
	LP	53	54	54	54	54	54	54	55	55	55

TABLE 4B
ORIFICE DRILL SIZE DECIMAL EQUIVALENTS

Drill No.	31	32	33	34	35	36	37	38	39	40	41	42	43
Decimal	.120	.116	.113	.111	.110	.1065	.104	.1015	.0995	.098	.096	.0935	.089
Drill No.	44	45	46	47	48	49	50	51	52	53	54	55	56
Decimal	.086	.082	.081	.0785	.076	.073	.070	.067	.0635	.0595	.055	.052	.0465

VIII. WIRING

CAUTION

For your personal safety, turn off electric power at service entrance panel before making any electrical connections.

All electrical work must conform with local codes and ordinances or, in their absence, with the National Electrical Code, ANSI/NFPA 70-latest edition.

ELECTRICAL POWER SUPPLY

Run a separate 120 volt, AC circuit from a separate fuse or circuit breaker in the service entrance panel with an ampacity rating per table 5. Locate a shut off switch at the furnace. Make connections from this switch to the furnace junction box as shown in the furnace wiring diagram.

TABLE 5

Model	Volts/Hz/PH	Total Amps	Blower Motor		Inducer Motor		Minimum Circuit Ampacity	Maximum Time Delay Fuse or HACR Circuit Breaker
			HP	FLA	HP	FLA		
IH60D36B IC60D36A	115/60/1	7.4	1/3	6.5	1/40	.90	15	15 amp
IH85D48B IC85D42A IL85D42A	115/60/1	9.9	1/3	9.0	1/40	.90	15	15 amp
IH115D48B IC115D48A IL115D48A	115/60/1	11.4	1/2	10.5	1/40	.90	15	20 amp
IL145D60A	115/60/1	13.4	3/4	12.5	1/40	.90	17	25 amp

ELECTRICAL GROUNDING

Recommended Grounding Method

When installed, the furnaces must be electrically grounded in accordance with local codes or in the absence of local codes, with the National Electrical Code, ANSI/NFPA No. 70-latest edition. Use a #14 AWG copper wire from green screw or green ground wire on the furnace to a grounded connection in the service panel or a properly driven and electrically grounded ground rod.

Alternate Ground Method

If the recommended grounding method is impossible, permanently ground the furnace from the ground connector to a grounded cold water pipe* using a separate, green colored, insulated conductor of appropriate size. THIS, HOWEVER, IS NOT RECOMMENDED.

*Cold water pipe must have metal continuity to electrical ground and not be interrupted by plastic, rubber or other electrically insulating connectors (including water meter or pump) without adding a jumper wire at these connections.

NOTE: DO NOT ground to a gas supply pipe. DO NOT connect to electric power supply until appliance is permanently grounded.

FIELD INSTALLED EQUIPMENT

Wiring to be done in the field between the furnace and devices not attached to the furnace, or between separate devices which are field installed and located, shall conform with the temperature limitation for Type T wire (63 degree F rise (36 degree C)) when installed in accordance with the manufacturer's instructions. Refer to wiring diagrams, pages 28 thru 30.

IX. VENTING APPLICATIONS

MARGINAL EXISTING VENT SYSTEMS (REPLACEMENT FURNACES)

Undersized Vents

The high economy furnaces have a special control circuit in which the pressure switch that proves operation of the combustion air blower and adequate combustion air will also respond to an undersized or restricted vent system and shut down the furnace before the combustion characteristics go "sour" and could potentially be forced out at the burner opening.

Oversized Vents

With an oversized vent or massive chimney, the flue products are sometimes unable to heat the inside surface of the chimney or vent pipe to a temperature above the dew point temperature. This also makes the establishment of a proper draft more difficult during the start-up of a cold furnace.

Other Factors Resulting In Condensation

Several additional factors may contribute to condensate formation in the vent. The physical mass of the vent is as important as size. Outside masonry chimneys and unlined interior masonry chimneys are unsatisfactory because the flue products do not contain enough heat to warm the massive brick wall of the chimney. Interior chimneys are acceptable only as detailed below under Vent Inspection Check List, Item 3.

Presale Inspection

The following information will describe for distributors, dealers, and installing contractors, a method for identifying an acceptable vent before the furnace is installed.

Existing vents must always be inspected before furnace installation. Most replacement dealers conduct this vent inspection and this practice is heartily endorsed. Vent inspections are doubly important when high-efficiency furnaces are installed, because of the reduced heat input to the vent. This inspection should be conducted before the sale of the furnace. Venting conditions should also be addressed before the sale by specifically stating that the quoted price either does or does not include modifications to the vent system. In any case, the inspection must be conducted before installation. This practice will reduce the possibility of call-backs to correct venting problems, and will increase customer satisfaction.

VENT INSPECTION CHECK LIST

In addition to compliance with the National Fuel Gas Code, certain vent system conditions should be avoided to minimize the possibility of condensation. Before the sale or installation of a replacement furnace, the following conditions should be noted:

1. Unlined masonry chimneys are unacceptable.
2. Outside masonry chimneys (one or more sides exposed to outdoor air) are unacceptable for venting of these furnaces.
 - A. It is recommended that the chimney be utilized as a path for venting to the outside by running B-vent up thru the chimney.
 - B. The B-1 vent must be installed in accordance with the terms of their listings and vent manufacturer's instructions. When type B-1 vent is used, an adapter is required between the draft outlet and B-1 vent.

- C. The B-1 vent must be mechanically supported in the masonry chimney.
 - D. The bottom of the B-1 vent cap must be at least 6 inches above the masonry chimney.
 - E. Another gas burning appliance such as a water heater may be common vented with the furnace. See section on common venting.
 - F. The top of the masonry chimney must be sealed with a metal cap to prohibit cold air entry down the chimney surrounding the metal vent.
3. Inside lined masonry chimneys can only be used on a common vent installation with a draft hood appliance such as a water heater. The draft hood appliance cannot be equipped with a vent damper as it will block the flow of dilution air required to keep the vent primed and dry.
 4. An inside masonry chimney is not acceptable for venting the furnace only.
 - A. It is recommended that the chimney be utilized as a path for venting to the outside by running B-vent up thru the chimney.
 - B. The B-1 vent must be installed in accordance with the terms of their listings and vent manufacturer's instructions. When type B-1 vent is used, an adapter is required between the draft outlet and B-1 vent.
 - C. The B-1 vent must be mechanically supported in the masonry chimney.
 - D. The bottom of the B-1 vent cap must be at least 6 inches above the masonry chimney.
 - E. The top of the masonry chimney must be sealed with a metal cap to prohibit cold air entry down the chimney surrounding the metal vent.
 5. Underground vent connectors or flue gas passages are unacceptable.
 6. No solid fuel burning appliances are permitted to be commonly vented with these furnaces.

SUGGESTED VENT REMEDIES

The following actions are suggested to improve vent system operation:

1. For any venting problem:
 - A. Set furnace to full input rate, *and
 - B. adjust blower temperature rise within nameplate range.

*NOTE: Care must be taken to derate furnaces installed at elevations more than 2,000 feet above sea level. Refer to "Orifice Sizing" section of this manual.
2. Vent connectors:
 - A. Avoid unnecessary elbows, bends, or restrictions in the flue system.
 - B. Insulate any long single-wall metal vent connectors or replace with double-wall pipe.
 - C. Avoid blowing conditioned air from the plenum or outside combustion air directly across the vent connector leaving the furnace. It may be necessary to insulate the vent connector to avoid this problem.

- D. When appliances are common vented, the common venting information on pages 32 and 33 must be adhered to.
3. For excess condensate from a type B-1 vent:
 - A. Insulate those sections of the vent exposed in unheated spaces and outdoors, or
 - B. Check for oversized vent system.
 - C. Provide suitable drain.
 4. For recurring lockout of the positive pressure sensor and/or flame roll-out sensor.
 - A. Check for adequate supply of combustion air. A very tight basement or furnace room can create air starvation which will trip the positive pressure sensor. An outdoor air supply to the furnace room or a louvered door may be required.
 - B. Remove all unnecessary elbows or restrictions from the vent system, especially in the first foot of vent connector above the furnace.
 - C. Check the vent system for any obstructions and correct as necessary.
 - D. Insulate vent connectors or replace them with double wall pipe.
 - E. If vent is undersized, replace it with a new properly sized vent.
 - F. Check for an exhaust air fan or device that may create a negative pressure within the structure. If such a device is present, provisions must be made to separate the furnace room or enclosure from the rest of the structure affected by the negative pressure.

Adequate combustion air must then be introduced to the furnace room for proper operation.

VENT RESIZING INSTRUCTIONS

When an existing furnace is removed from a venting system serving other appliances, the venting system is likely to be too large to properly vent the remaining attached appliances.

The following steps shall be followed with each of the appliances remaining connected to the common venting system, placed in operation one at a time while the other appliances remaining connected to the common venting system are not in operation.

1. Seal any unused openings in the common venting system.
2. Visually inspect the venting system for proper size and horizontal pitch and determine there is no blockage or restriction, leakage, corrosion, and other deficiencies which could cause an unsafe condition.
3. Insofar as is practical, close all building doors and windows and all doors between the space in which the appliances remaining connected to the common venting system are located and other spaces of the building. Turn on clothes dryers and any appliance not connected to the common venting system. Turn on any exhaust fans, such as range hoods and bathroom exhausts, so they will operate at maximum speed. Do not operate a summer exhaust fan. Close fireplace dampers.
4. Follow the lighting instructions. Place the appliance being inspected in operation. Adjust thermostat so appliance will operate continuously.

5. Test for spillage at the draft hood relief opening after 5 minutes of main burner operation. Use the flame of a match or candle, or smoke from a cigarette, cigar, or pipe.
6. After it has been determined that each appliance remaining connected to the common venting system properly vents when tested as outlined above, return doors, windows, exhaust fans, fireplace dampers and any other gas-burning appliance to their previous conditions of use.
7. If improper venting is observed during any of the above tests, the common venting system must be corrected.

VENTING TROUBLESHOOTING PROCEDURES

TABLE 6

Symptoms	Possible Causes	How To Check And/Or Correct
Downdrafting through the furnace	Negative pressure within the structure caused by exhaust fan of device	Check for downdraft in vent where vent connects to unit with flame from a candle or a match, or smoke from a cigarette, cigar, or pipe.
	Location of vent terminal	Verify that vent termination is position with the recommended specifications stated in this manual.
	Incorrect or absent vent terminal	Verify that the vent terminal is designed for and is compatible with the venting system.
Condensation in venting system	Oversized venting system	Look for condensation in or around vent pipe joints or around flue connections at furnace. To correct this condition, design the venting system in accordance with the National Fuel Gas Code, ANSI-Z223.1-latest edition and addenda Z223.1a latest edition
	Uninsulated vent installed in an unconditioned space	Check for condensation in or around vent pipe joints. Also check around the flue connecting areas on the unit. Insulate the vent in unconditioned space to prevent the above condition.
	Running vent as a liner up an existing chimney without capping off the chimney	Check to make sure the space between the vent and the inside of the chimney has been sealed. With this space being open, it may allow too much cold air in and around the vent pipe allowing the flue products to condense causing condensation back at the unit.

VERTICAL VENTING INSTRUCTIONS

This furnace may be vented directly to the outside through a suitable chimney. THIS FURNACE AS SHIPPED FROM THE FACTORY IS SUITABLE FOR A DEDICATED FLUE ONLY. It is not suitable for use with PVC, CPVC, ABS type plastic pipe. With the addition of optional field-installed Common Venting Kit, it is suitable to common vent this furnace along with another gas burning appliance to a single chimney for ease of installation. Refer to section on Common Venting beginning on Page 32 of this instruction manual for complete details. The vent must be in accordance with Part 7, Venting of Equipment, of the National Fuel Gas Code, ANSI Z223.1-latest edition and addenda, Z223.1a-latest edition, or applicable provision of the local building codes.

This unit may also be horizontally vented with high temperature plastic pipe. If this type of vent is desired, the proper material and installation must be taken into consideration. Refer to the sidewall venting instructions section on page 17.

Most installing dealers check the suitability of the vent or chimney when installing a replacement furnace. Their observations and experience have produced a set of guidelines for judging the suitability of the vent or chimney. Generally, these guidelines have proven workable. They have been modified over a period of years, taking successes and setbacks into account. For the last 30 years, furnace technology has remained relatively constant. That technology is now changing. With the benefits that new technology brings, we must all reevaluate our past practices and make changes where needed. For those who, as a matter of course, check add-on and replacement vents according to the provisions contained in the National Fuel Gas Code (NFPA 54-latest edition or ANSI Z223.1-latest edition), these installation instructions contain only supporting information. For those who do not currently ensure that the existing vents satisfy these requirements, we provide the following cautions and guidelines.

General Instructions

1. Vent connectors serving Category I and Category II appliances shall not be connected into any portion of mechanical draft systems operating under positive pressure.
2. For Category II, III, and IV furnaces, the venting system shall be installed in accordance with the furnace manufacturer's installation instructions.
3. This furnace shall be connected to a factory built chimney or vent complying with a recognized standard, or a masonry or concrete chimney lined with a lining material acceptable to the authority having jurisdiction.
4. The vent connector must be aluminum pipe and shall be the same size as the flue outlet on the furnace. Keep the vent as short and direct as possible. Type B-1 pipe is recommended.

This applies only when not horizontally venting with plastic pipe. When horizontally venting with plastic pipe, refer to the sidewall venting instructions below.

5. Maintain a minimum clearance of 6" (1" for B-1) to any portion of the vent connector from any adjacent combustible materials. Single wall vent connector is permitted only within the same space (room or area) as the furnace. B-1 vent is required whenever the vent is enclosed or passes through floors, walls, ceilings, roofs or furred-out spaces. Joists, studs, floors, dry wall, paneling, sheathing, rafters, roofing and other materials classified as combustible must not be closer than 1" clearance to B-1 vent.
6. If connected into masonry chimney, the vent pipe must be inserted into, but not beyond the inside wall of the chimney.
7. The gas vent must extend at least 2 feet above the highest point where it passes through the roof of a building (3 feet for a chimney) and at least 1 foot higher than any portion of a building within a horizontal distance of 10 feet. See Figure 5.
8. The vent pipe system shall be installed so as to avoid excessive turns which create unnecessary resistance to flow of vent gases.
9. Horizontal runs shall be as short and direct as possible. The maximum length of a single-wall vent pipe shall not exceed 75 percent of the height of the vent system. The maximum length of a Type B-1 double wall flue connection shall not exceed 100 percent of the height of the vent system.
10. All horizontal vent pipe shall be pitched upward from the furnace at least 1/4 inch per foot.
11. All vent systems shall be adequately supported to maintain proper clearances, to prevent physical damage, and to prevent separation to joints.
12. Vents passing through an exterior combustible wall must use a ventilated wall thimble. See Figure 6.
13. Vents passing through floors or ceilings must be fire-stopped. See Figure 7 and Figure 8.

14. Horizontal portions of the vent system shall be supported to prevent sagging. Pipe strap or equivalent means should be used every 3 to 5 feet depending upon pipe joint lengths.
15. A furnace shall not be connected to a chimney flue serving a separate appliance designed to burn solid fuel.

FIGURE 5 -- CHIMNEY OR VENT CAP INSTALLATION

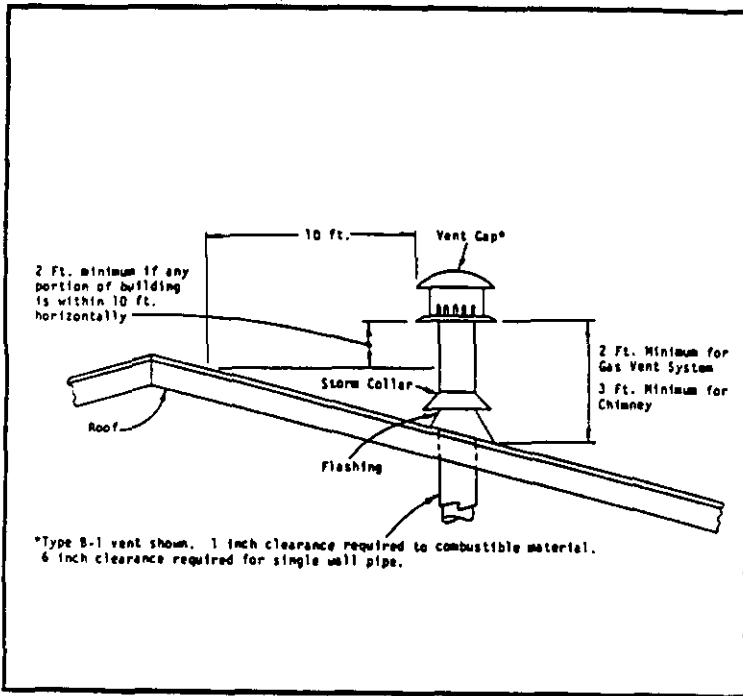

FIGURE 7 -- VENT THROUGH FLOOR

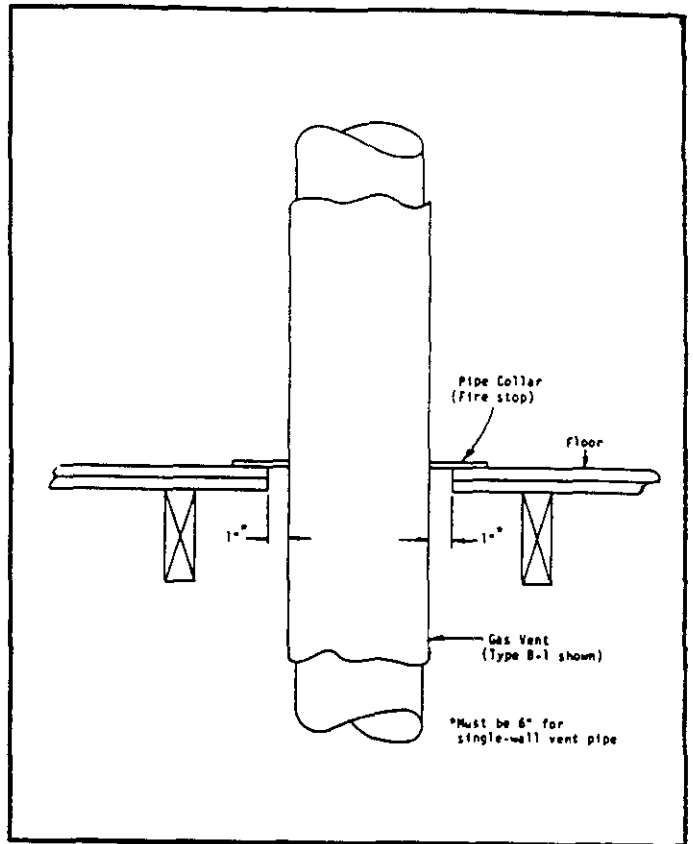

FIGURE 6 -- HORIZONTAL RUN PENETRATING COMBUSTIBLE WALL

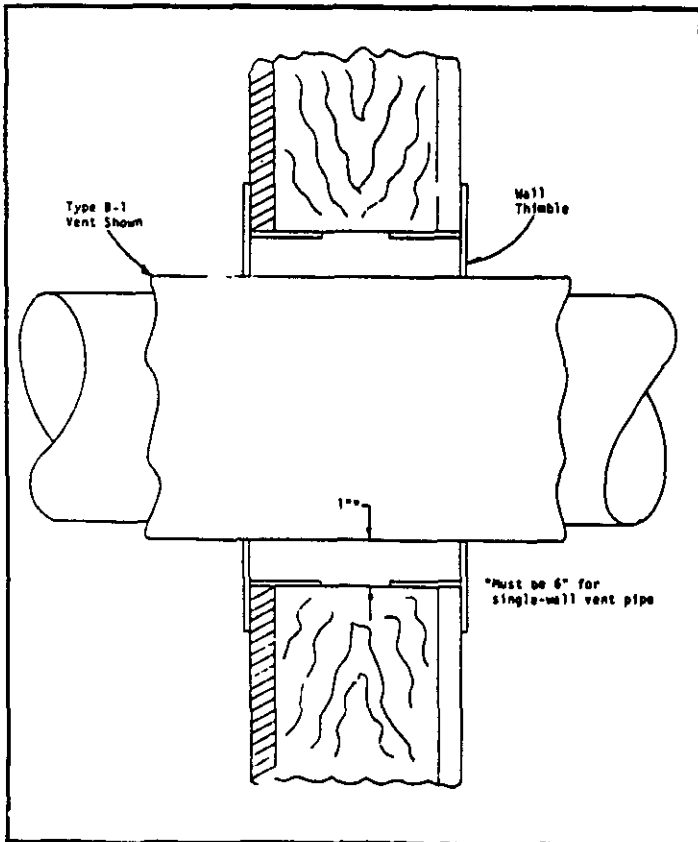
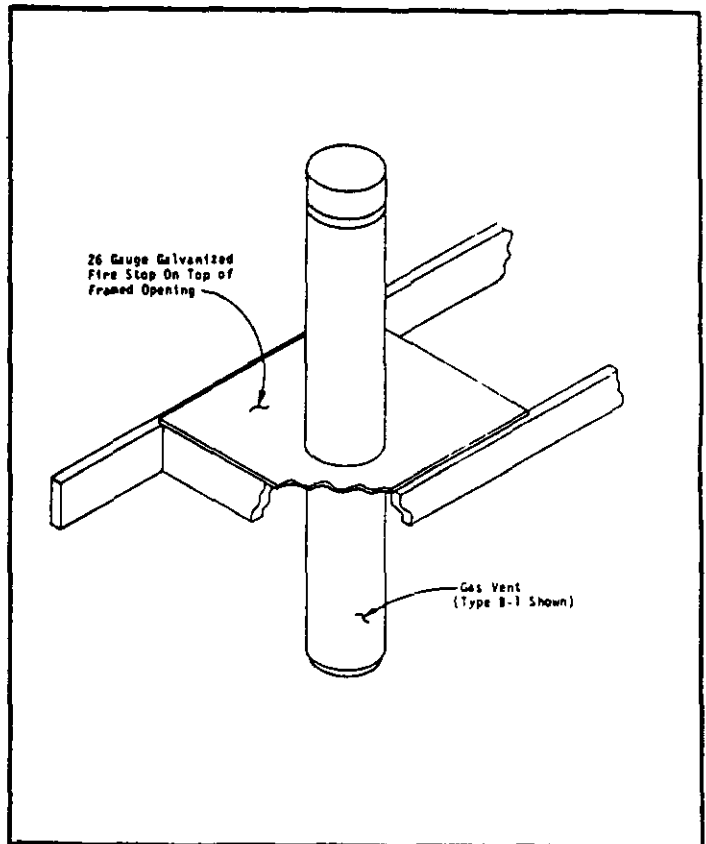

FIGURE 8 -- VENT THROUGH CEILING



SIDEWALL VENTING INSTRUCTIONS

This furnace may be vented horizontally and vented through a sidewall only when using an approved, sealed, high temperature plastic vent system as detailed below. When installed with this type of venting system, the pressure within the vent becomes positive pressure and thus requires the special sealed vent system.

This change in pressure changes the furnace from a Category I to a Category III appliance. The marking on the furnace need not change as this construction has been AGA design certified as a dedicated alternate vent system.

The sealed vent system must be a dedicated vent and cannot serve any other fuel burning appliance. Common venting is not permitted for this type of venting installation. The requirements and limitations of horizontal venting are very strict. All horizontal vent installations must be made in accordance with these instructions.

Approved Sidewall Vent Components

TABLE 7 APPROVED SIDEWALL VENT COMPONENTS

Description	Plexco Pt. No.	Hart & Cooley Pt. No.
3" x 5 ft. pipe	901220	3UP5
3" x 10 ft. pipe	902474	3UP10
3" coupling	905630	3UC
3" tee	905268	3UT
Drain adapter	906646	3UDP
3" x 90 Deg. Elbow	905269	3UES90 or 3UE90
3" x 45 Deg. Elbow	905639	3UE45
Wall Thimble 3"	See Note (1)	3UWT
Termination	901971	3UTT
4 to 3 reducer	905744	4UR3
4" x 5 ft. pipe	903851	
4" coupling	905807	
4" x 90 deg. elbow	905772	
4" tee	906883	
Condensate drain	903855	
Termination	906882	
Wall Thimble 4"	See Note (2)	

NOTES: 115,000 BTU INPUT MODELS:

For west or north facing sidewall vents, use 4" piping. For south or east facing vents, 3" piping can be used for up to 20 equivalent feet. Over 20 equivalent feet, use 4" piping all the way to furnace.

145,000 BTU model must use 4" piping all the way to furnace.

(1) Use 905662, 906972, or 905295.

(2) Use 906979, 907084, 907094, or 907103.

Approved Sealants

NAPA Balkamp--765-1469
 GE--C-550
 Hart & Cooley--3URTV
 Dow Corning--732
 Or equivalent silicone adhesive (400 degree F)

General Instructions

1. The maximum vent length is 40 total equivalent feet with each 45 degree elbow counting as 2-1/2 feet and each 90 degree elbow counting as 5 feet. Do not count the vent termination in this measurement.

Example: 20 feet of straight vent pipe with three 90 degree elbows equals 35 equivalent feet.

2. The minimum vent length is 3 feet and one 90 degree elbow.
3. All horizontal runs must slope upwards not less than 1/4 inch per foot from the furnace to the vent terminal.

4. All horizontal pipe must be supported every five feet to prevent sagging, low spots in the vent may collect condensate and prevent furnace operation.
5. All horizontal vent installations must have a minimum 18" vertical rise out of furnace outlet. See Figure 9.
6. A 2 inch clearance from combustibles must be maintained for the entire vent system.
7. All horizontal vent installations must have a drain fitting within the first 18 inches from the furnace. See Figure 9.
8. All drain lines from the drain fitting must be installed in a manner to form a water trap in the drain line. See Figure 9.
9. Any drain line located in an unconditioned space must be be protected from freezing. The freezing of the drain line can cause drain blockage in condensate entering the combustion air blower and causing premature failure.

FIGURE 9

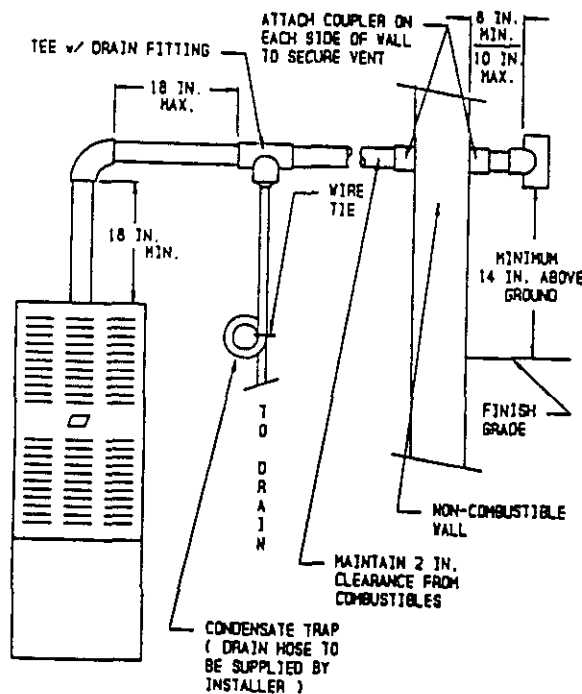

Location of Vent Terminal

The vent location must meet the requirements listed in the following instructions or applicable codes, whichever specifies the most clearance or strictest limitations.

1. The vent terminal must be a minimum of 14 inches above ground level, above normal snow levels and a minimum of 8 (maximum 10) inches out from wall. See Figures 9 and 10.

The bottom of the vent terminal must be at least 14" above finished grade. A vertical riser may be required to achieve this (Figure 10). If normal snow accumulation is a consideration, a vertical riser will be required to raise vent terminal to a point at least 12" above the anticipated snow level (Figure 10).

Because of additional piping being exposed to the outside weather, insulation is required to keep from freezing.

FIGURE 10

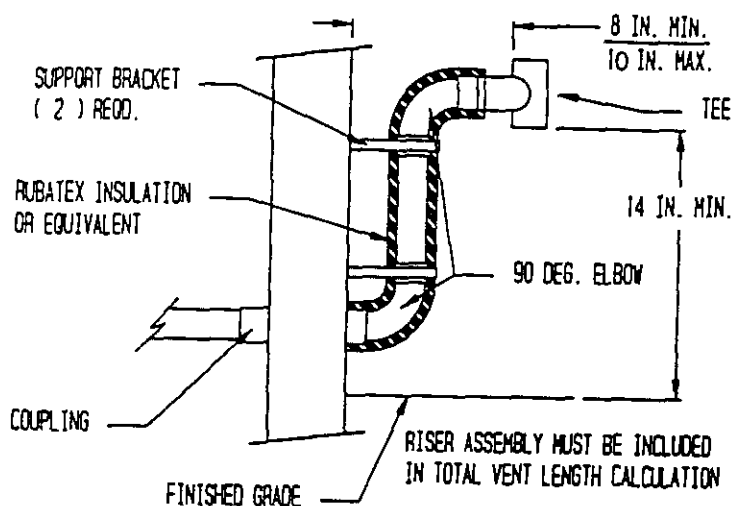

2. Not above any walkways.
3. Should the vent terminal be located adjacent to a public walkway, it must be not less than 7 feet above ground.
4. The vent terminal must be 4 feet from and not above any door or window.
5. At least 3 feet above any forced air inlet terminal servicing any other appliance located within 6 feet horizontally.
6. At least 4 feet horizontally from electric meters, gas meters, regulators and relief equipment.
7. Under certain wind conditions some building materials may be affected by flue products expelled in close proximity to unprotected surfaces. Sealing or shielding of the exposed surfaces with a corrosion resistant material (such as aluminum sheet) may be required to prevent staining or deterioration.
8. Do not locate vent too close to shrubbery as flue product may stunt or kill them.

CAUTION

As a natural part of the unit's operation, normal products of combustion, including water vapor are vented to the atmosphere. Since the outside air temperature can be well below 32 degree F., it is possible that the water vapor in the exhaust will freeze, causing an ice buildup around the discharge opening of the pipe. During periods of extremely cold weather and prolonged operation of the furnace, this ice build-up could become quite large. The manufacturer does not recommend the installation of these units in locations above frequent vehicular and/or pedestrian traffic. The ice build-up could present a potentially hazardous situation if it becomes dislodged. The manufacturer will NOT be held responsible for any injury or property damage resulting from any improper installation.

Assembly Of Vent

Follow pipe manufacturer's instructions for cutting pipe and sealing pipe at various connections.

Vent Passage Through A Combustible Wall

Vent passage through a combustible wall is permitted when the instructions below are followed.

1. When penetrating a framed wall (inner and outer wall with space between the two walls) use the wall thimble listed in Table 7. This thimble can be used on walls 2 inches to 8 inches thick. If penetrating a combustible wall which is 30 linear feet or more from the appliance, no thimble is required and a 0 inch clearance is acceptable. If the wall is less than 30 linear feet from the appliance, the wall thimble must be used. See Figure 11.

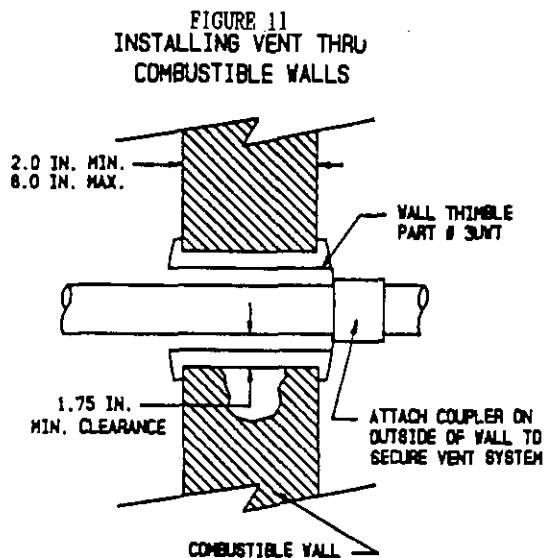

2. When penetrating a single wood wall such as a header, footer or joist (2x8, 2x10, 2x12, etc.) a 1 inch clearance must be maintained. This is achieved by cutting a 5 inch diameter hole in the wood, and with a 6" x 6" or larger sheet of non-combustible material (aluminum, galvanized, etc.) cut a 3 inch diameter hole in the center. Fasten this sheet of material to the outside of the header or footer with the 3 inch hole centered inside of the 5 inch hole. The vent pipe can now be run through the 3 inch hole while maintaining the 1 inch clearance from combustibles. If the combustible wall is located 30 linear feet or further from the appliance, the above steps are not necessary and a 0 inch clearance is acceptable. See Figure 12.

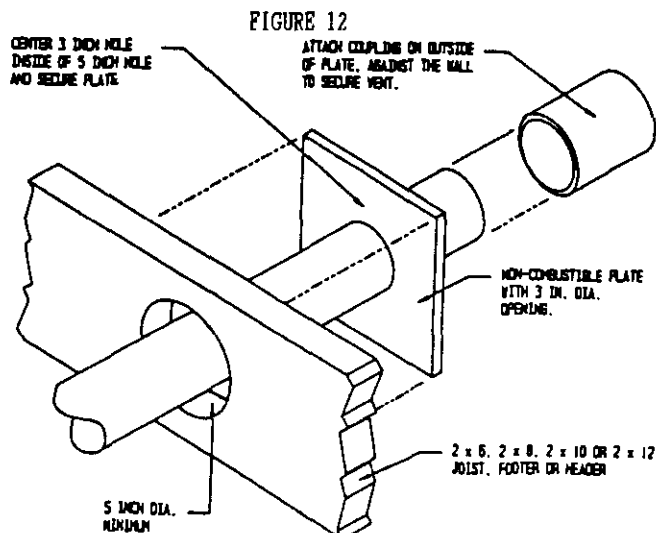

X. THERMOSTAT

Install the thermostat in accordance with instructions packed with it. Locate the thermostat 4-1/3 feet from the floor on an inside wall away from drafts, warm air registers and floor or table lamps. Refer to furnace wiring diagrams for connections.

All 24V wall thermostats have heat anticipators to compensate the thermostat for various system controls and allow the best possible cycle rates. Some anticipators are fixed and require no adjustment. However, the majority of wall thermostats have adjustable anticipators and do require adjustment to match the current rating of the gas valve. The nominal heat anticipator setting for these furnaces is .80A.

Failure to adjust the anticipator lever to correspond to the actual current draw through the thermostat will cause severe short cycling if set too low and room temperature may never attain the thermostat set point, and if set too high, will cause room temperature to overshoot the set point.

XI. BLOWER OPERATION

All models are three or four speed direct drive and are equipped with a heating-cooling blower relay. When matched with the appropriate wall thermostat offers manual blower operation from the wall thermostat for air circulation.

Blower Speed Adjustment

WARNING

When servicing or changing blower motor speeds, always turn off electrical power supply to the furnace to prevent possibility of electrical shock hazard.

In the event that more air or less air is desired for either the heating or cooling mode, blower speeds may be adjusted by removing the undesired motor lead from its appropriate wire and replacing it with the speed desired.

WARNING

Unused motor wires within the junction box are electrically energized when the motor is operating and must be adequately insulated. Failure to do so can cause the motor to short out or slow down which could result in the furnace overheating and/or electrical shock and/or fire hazard.

CAUTION

After the furnace is operating with filters installed and all cabinet panels are in place, check the temperature rise through the unit to insure it is within the range specified on the furnace rating plate. If it is not, adjust blower speed until the temperature rise is within specified range.

XII. FILTERS

All models are shipped with filters. See Table 8 for sizes. Hi-Boy models have the filters in their intended positions. Hi-Boy models are shipped with filter on the left side. They can alternately be located on right side or bottom. See following information. The counterflow models require a bracket installation and final filter location projects into return air plenum attachment to furnace, see Figures 16 and 17. Refer to Figures 18 and 19 for Lo-Boy models.

TABLE 8

FILTER SIZES FOR GAS FURNACES		
Model	Size	
IL85D42A Lo-Boy	(1) 18-3/4 x 20 P	
IL115D48A Lo-Boy	(1) 22-3/4 x 20 P	
IL145D60A Lo-Boy	(2) 13 x 20	P
IH60D36B Hi-Boy	(1) 16 x 25	P
IH85D48B Hi-Boy	(1) 16 x 25	P
IH115D48B Hi-Boy	(1) 16 x 25	P
IC60D36A Counterflow	(1) 15 x 20	P
IC85D42A Counterflow	(2) 10 x 20	P
IC115D48A Counterflow	(1) 15 x 20	P
	(1) 10 x 20	P

P - Permanent

Filter Locations--Removal and Replacement Procedures--Hi-Boy Models

To remove filters from ALL sectional Hi-Boys, first remove the upper burner door and then the lower blower compartment door by grasping top of door and pull up and away from the furnace. Then, remove the "S" clip and spring by pulling the clip towards the front of the furnace.

For right hand side filter location, relocate filter and retaining spring assembly to right side filter brackets.

FIGURE 13

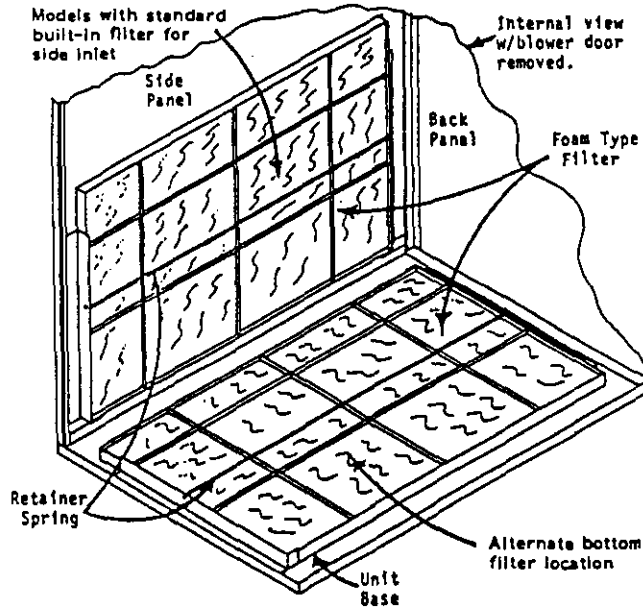

The filter may now be removed simply by pulling it towards the center of the furnace and outward.

The location may vary, depending on which side the installer located the return air duct.

This filter is the permanent high velocity type foam filter which may be washed and used over and over. DO NOT replace it with a fiberglass filter of the same size.

To replace filter, reverse the above process.

FIGURE 14

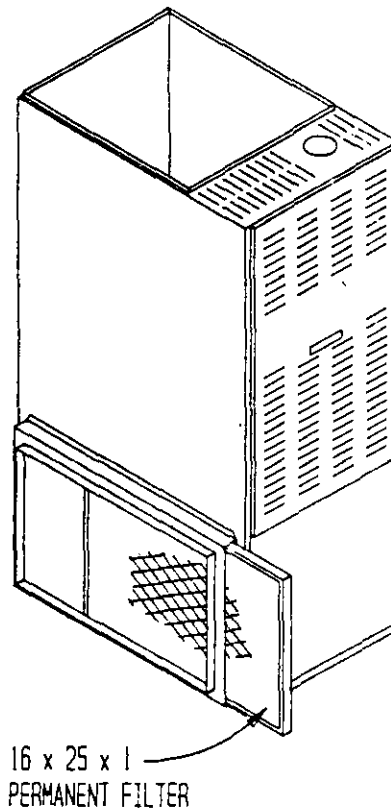

To remove filter from the optional external filter rack, grasp the exposed end of the filter and pull from the filter rack.

The location may vary, depending on which side the installer located the return air duct.

This filter is the permanent high velocity type foam filter which may be washed and used over and over. DO NOT replace it with a fiberglass filter of the same size.

To replace filter, reverse the above process.

Alternate Bottom Filter Location

All Hi-Boy models have a removable panel on the base for a bottom return air installation.

To utilize this feature, remove the fill plate by bending the four tabs up 90 degrees. Relocate filter retainer spring from side to bottom brackets. Leave the four tabs bent in the upright position as they will now serve to keep the filter positioned left to right.

On the 60,000 model the standard 16x25x1 filter must be cut down to 12x25x1. See illustration below.

FIGURE 15

Cut along top of rib with metal shears. Remove top 4 inches.

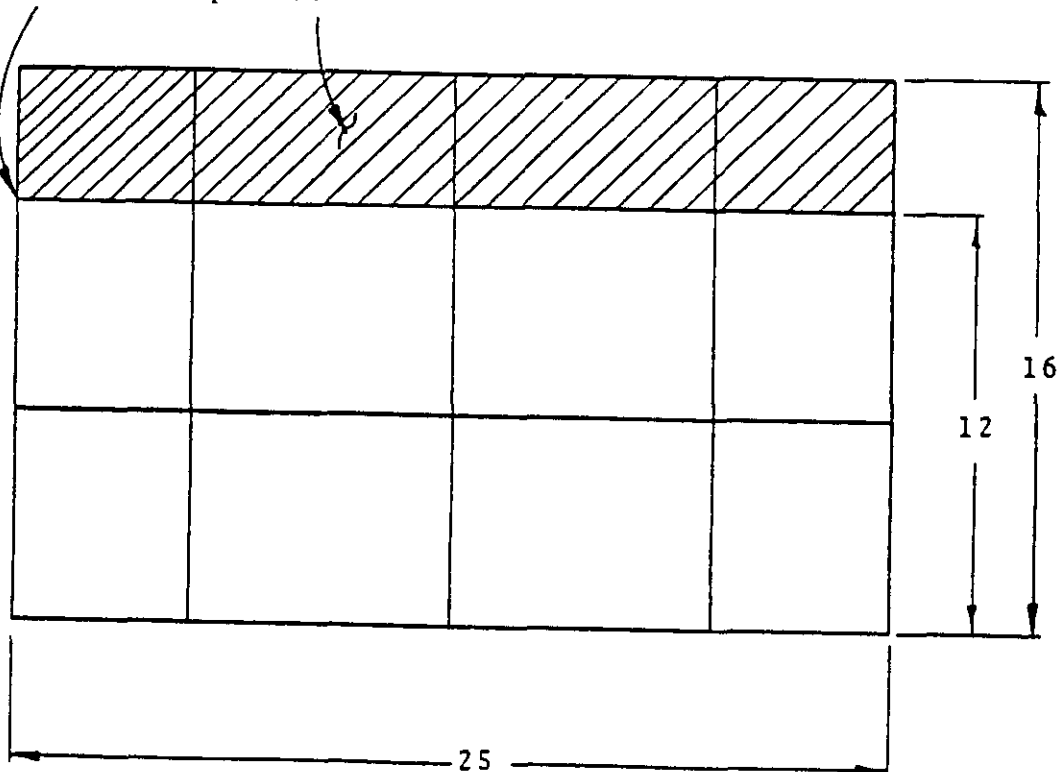

Filter Locations--Counterflow Models

Counterflow models normally have filters installed in the return air plenum above the furnace unless a common return air/filter grille is used.

The electrical switch should be turned "off" before the front door to furnace is removed. After removing the front door, remove the left side filter door in the upper section of the furnace. Refer to Figures 16 and 17 below for proper filter locations.

FIGURE 16
IC60D36A

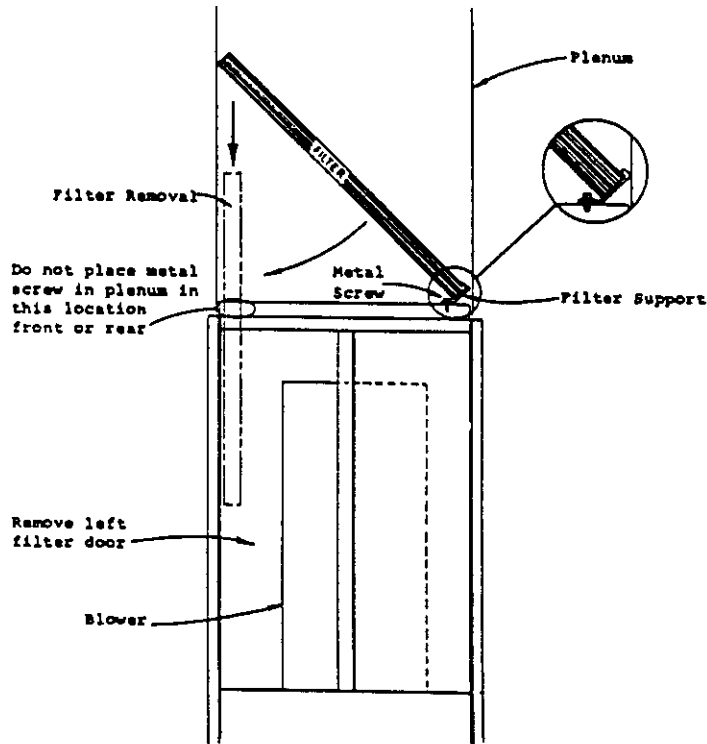

Attach filter support to furnace as shown with two sheet metal screws. The filter can be installed and removed through the left filter door.

FIGURE 17
IC85D42A, IC115D48A

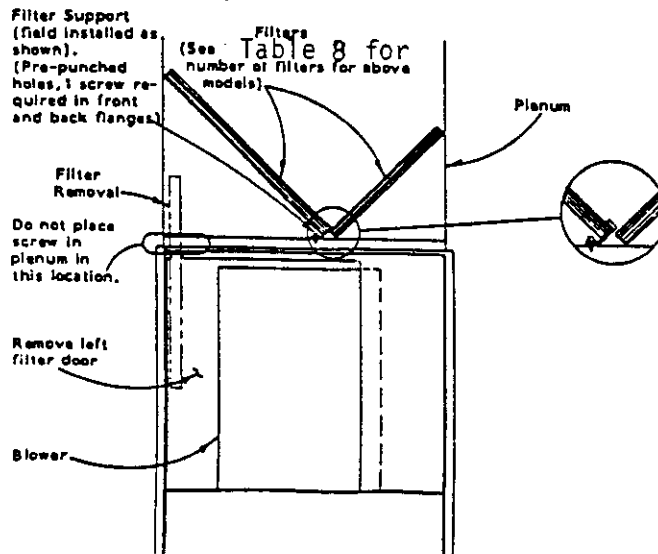

Filter Locations--Lo-Boy Models

Lo-Boy models have the filters installed in the return air cabinet section of the furnace. They are accessible from the rear of the furnace by removing the blower/filter access door. The electrical switch should be turned "off" prior to removing the access door. Refer to Figures 18 and 19 below.

FIGURE 18

IL85D42A, IL115D48A

REAR VIEW WITH BLOWER/
FILTER ACCESS DOOR REMOVED

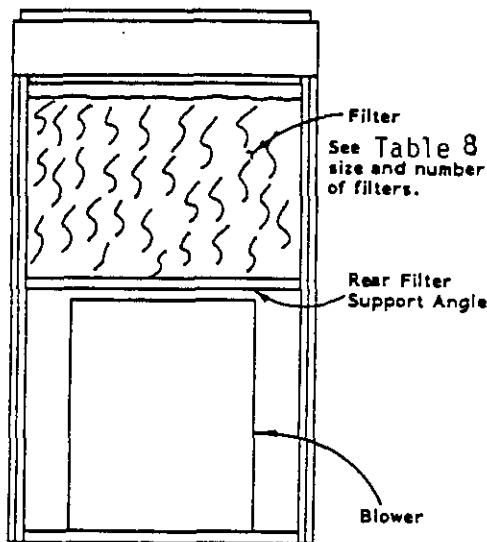
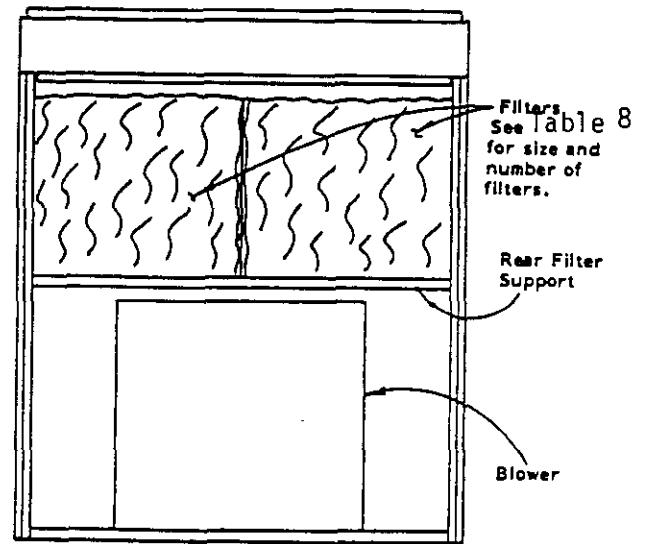

FIGURE 19

IL145D60A

REAR VIEW WITH BLOWER/
FILTER ACCESS DOOR REMOVED



XIII. SEQUENCE OF OPERATION

On a call for heat from the thermostat the DPST relay coil is energized through the normally closed contact of the air proving pressure switch. When the relay coil is energized, the relay contacts close which simultaneously energizes the induced draft blower and locks in the relay coil. Once sufficient draft is established, the ignition module will be energized through the normally open contact of the pressure switch. The pilot ignition electrode will begin to spark and pilot valve will be energized allowing pilot gas flow. Upon establishment of pilot burner flame, adequate flame for burner ignition is proved to control module at which point main gas valve is energized and spark is discontinued.

This unit is equipped with a flame rollout switch which is wired in series with the control circuit. This is a manual reset switch and is used for the purpose of preventing possible fire hazard in the event of a system malfunction. If this switch has opened the control circuit, there could be a possible system malfunction. Some of the conditions that might cause a rollout to occur are blockage or sooting of primary heat exchanger, over-firing of furnace due to improper main burner orifices or incorrect manifold pressure, insufficient combustion air, or installation deficiencies with respect to return air duct design or sizing.

Once the problem has been resolved, reset the switch by pressing down on the black button on top of the switch.

XIV. MAINTENANCE INSTRUCTIONS

The furnace and its vent system should be inspected annually by a qualified service agency, generally prior to the heating season.

NOTE: Prior to the start of any of the following maintenance procedures shut off all power to the unit.

Routine maintenance procedures are the responsibility of the owner and are contained in the Owner's Manual. These are briefly outlined below:

1. Air Filters. Check the condition on at least a monthly basis when the furnace is in use or replace whenever it is necessary.
2. Lubrication Requirements. Direct drive motors are permanently lubricated, no maintenance required. The induced draft blower motor should be oiled every six months with SAE20 motor oil.
3. Check Temperature Rise. Adjust blower speed if necessary to obtain a temperature rise within the range specified on the furnace rating plate.
4. Basic Examination of Furnace. Visual inspection of pilot flame and the main burners. Also inspection of the burner compartment and the vent system for sooting and scaling.
5. Periodic Inspection of the Vent System. Visual inspection of the vent system from the furnace to the chimney for any leaking or defective parts.
6. Periodic Inspection of Drain Line. On installations with sidewall venting the drain line should be inspected for blockage or possible freezing. Blockage of drain lines can result in premature combustion air blower failure.

XV. REPLACEMENT PARTS

Replacement parts for the gas furnaces are available through local distributors.

Parts list covering all of the normally serviceable items are listed in the Replacement Parts Manual supplied with this furnace. When ordering parts or making inquiries pertaining to any of the furnaces covered by these instructions, it is very important to always supply the COMPLETE model number and serial number of the furnace. This is necessary to assure that the correct parts (or approved alternate parts) are issued to the service agency.

The replacement parts manual numbers are as follows:

IH Series Hi-Boy -- 2110-853
IC Series Counterflow -- 2110-854
IL Series Lo-Boy -- 2110-855

XVI. SERVICE AGENCY PROCEDURES

1. The intermittent pilot lights only when the thermostat calls for heat and the main burner lights within a few seconds thereafter. It is recommended that any observation of pilot or main burner operation be done only with the burner compartment door in place and viewing through the combustion air slots.

The pilot flame can be adjusted by removing the pilot adjustment cover screw. Turn inner adjustment screw clockwise to decrease and counterclockwise to increase pilot flame. Be sure to replace cover screw after adjustment to prevent possible gas leakage.

FIGURE 20
INTERMITTENT PILOT

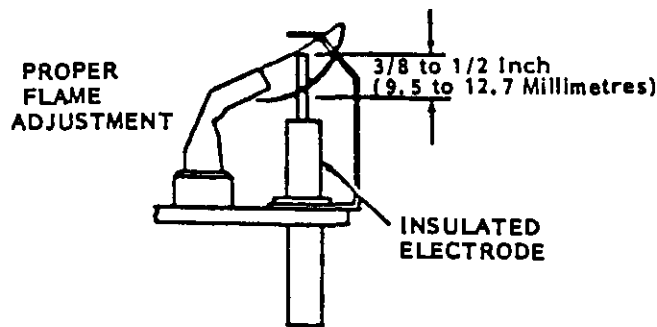

2. Observe the main burners in operation, viewing through the combustion air slots. The flame should be mostly "blue" with possibly a little orange at the tips of the flames. The flames should be in the center of the heat exchanger compartments and not impinging on the heat exchanger surfaces themselves.

The inner cone of the flame as shown below should be approximately 1 inch to 1-1/4 inches tall from the burner ports when natural gas is used. When LP gas is used, the inner cones should be approximately 1/2 inch tall from the burner ports. If no primary air adjustment has been made after the furnace has been converted for use with LP gas, the inner cones may be lying flat on the burner ports. This condition can be corrected by decreasing the amount of primary air in the burners. Slowly close down the primary air shutters at the end of each burner until the desired inner cone height is obtained. Be sure to tighten all the air shutter set screws once the adjustment has been made.

Observe the fire until the blower starts (there is a normal delay period until the heat exchanger warms up). There should be no change in the size or shape of the flame. If there is any wavering or blowing of the flame on the blower start-up, it is an indication of a possible leak in the heat exchanger.

The air shutters are factory adjusted completely open for use with natural gas. If flashback occurs, the air shutters may be closed slightly to prevent the flashback. If converted to LP gas, the air shutters must be adjusted as specified above.

FIGURE 21

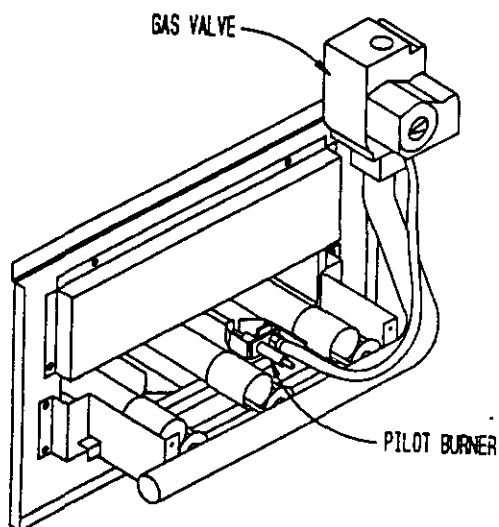
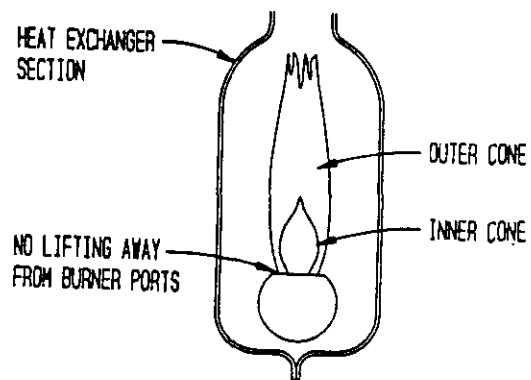

FIGURE 22



CONNECTION DIAGRAM

LADDER DIAGRAM

DANGER: ELECTRICAL SHOCK HAZARD.
DISCONNECT POWER BEFORE SERVICING.

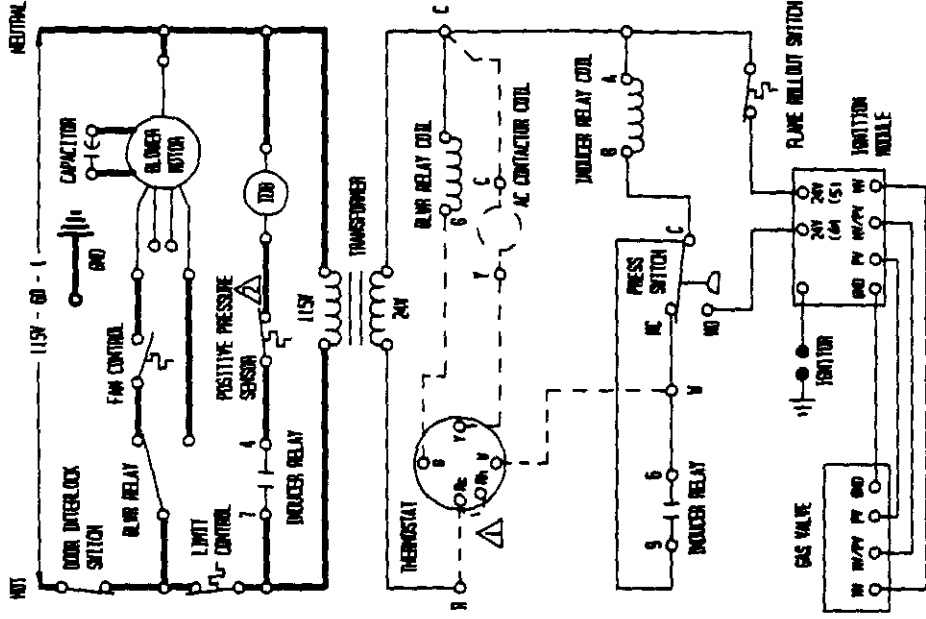
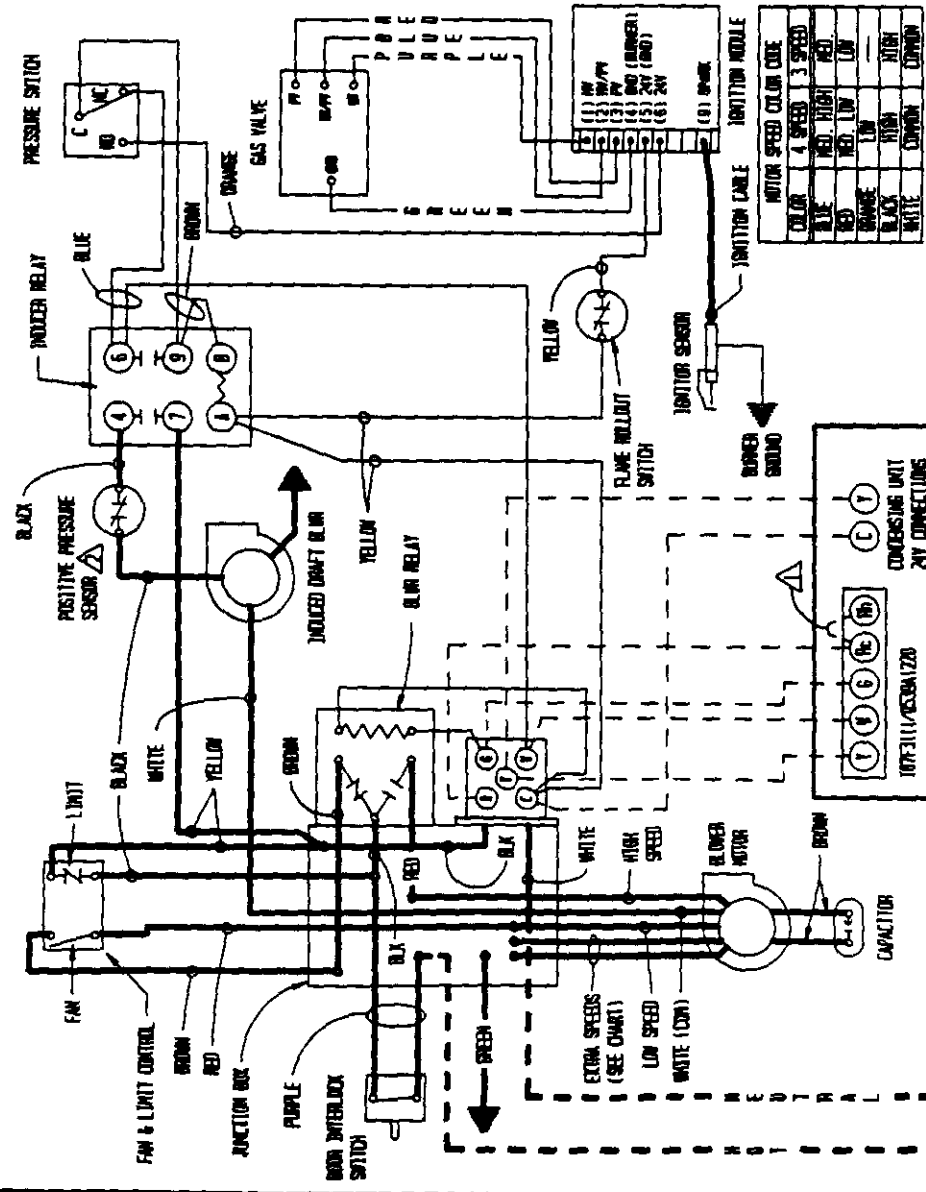

△ JUMPER REQUIRED IN REBUILT.
△ FIELD INSTALLED, OPTIONAL POSITIVE PRESSURE SENSOR REQUIRED ONLY FOR COMMON VENTING INSTALLATIONS.

USE COPPER CONDUCTORS ONLY

LOW VOLTAGE
HIGH VOLTAGE

FACTORY WIRING
FIELD WIRING

IF ANY OF THE ORIGINAL WIRE AS SUPPLIED WITH THE APPLIANCE MUST BE REPLACED, IT MUST BE REPLACED WITH WIRING MATERIAL HAVING A TEMPERATURE RATING OF AT LEAST 105°C. EXCEPT THE IGNITION CABLE WHICH IS 250°C. HIGH VOLTAGE CABLE.

3P-SERIES UPFLOW GAS FURNACE

4046-118 A

115-60-1

LADDER DIAGRAM

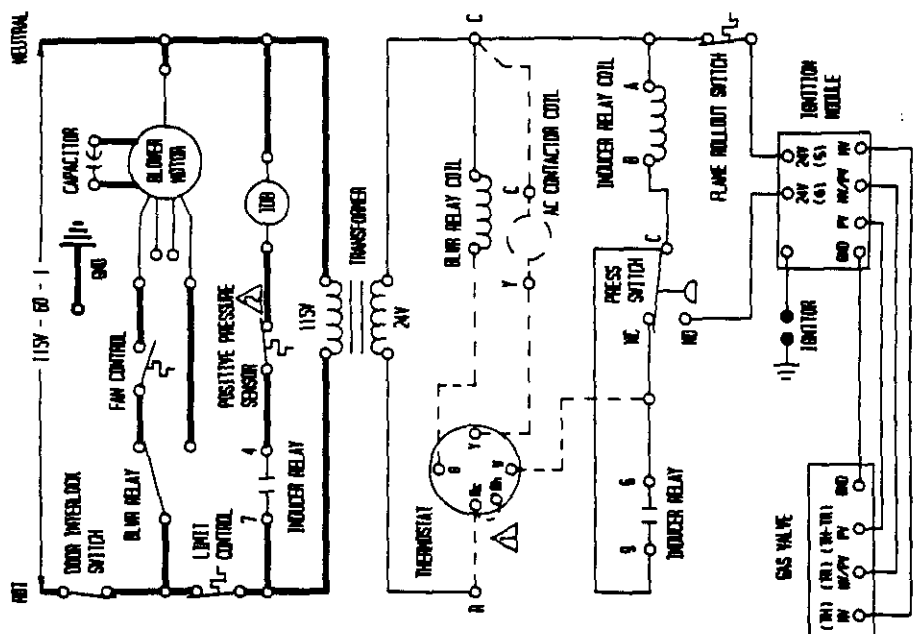

IF ANY OF THE ORIGINAL WIRE AS SUPPLIED WITH THE APPLIANCE MUST BE REPLACED, IT MUST BE REPLACED WITH WIRING MATERIAL HAVING A TEMPERATURE RATING OF AT LEAST 105°C. EXCEPT THE IGNITION CABLE SWITCH IS 250°C. HIGH VOLTAGE CABLE.

4046-120B

CONNECTION DIAGRAM

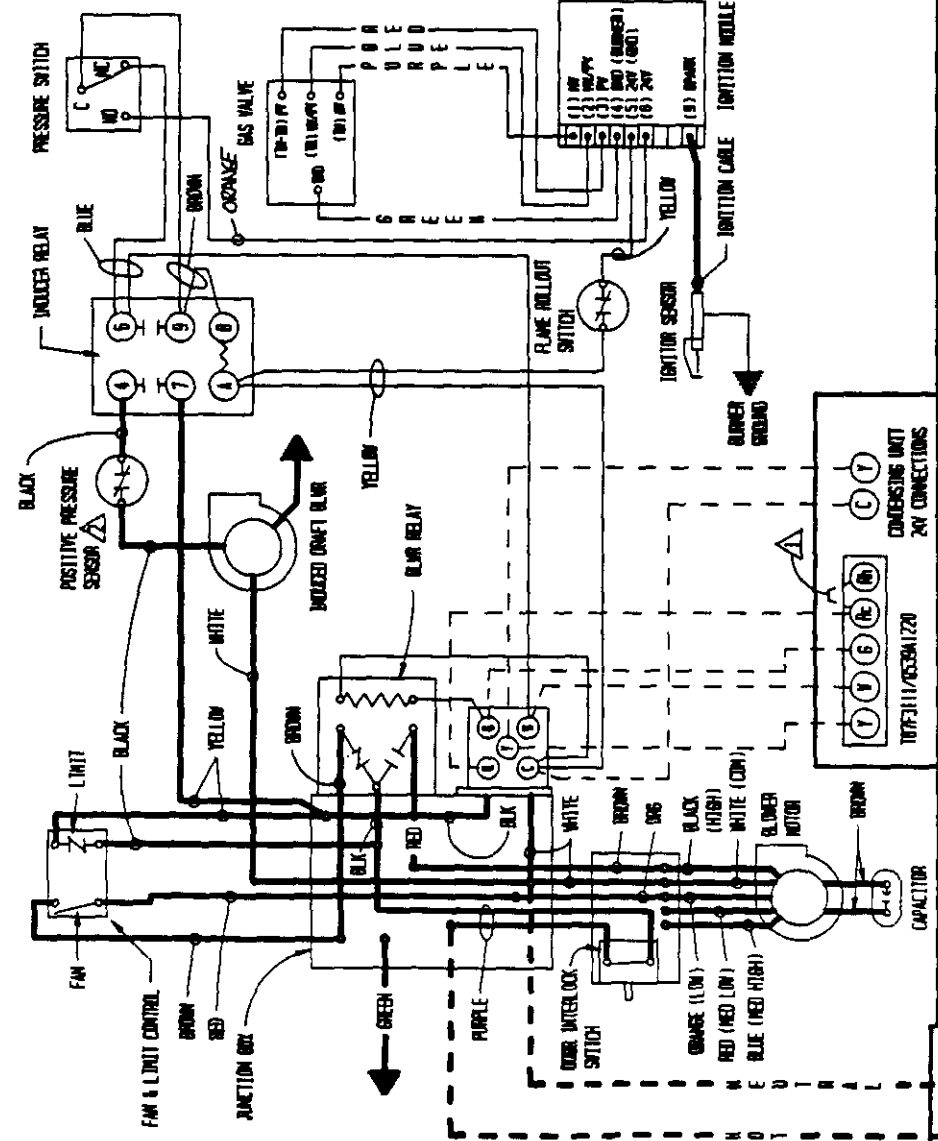

IF ANY OF THE ORIGINAL WIRE AS SUPPLIED WITH THE APPLIANCE MUST BE REPLACED, IT MUST BE REPLACED WITH WIRING MATERIAL HAVING A TEMPERATURE RATING OF AT LEAST 105°C. EXCEPT THE IGNITION CABLE SWITCH IS 250°C. HIGH VOLTAGE CABLE.

4046-120B

USE COPPER CONDUCTORS ONLY

JUMPER AC-FR REQUIRED ON 633A120.
FIELD INSTALLED, OPTIONAL POSITIVE PRESSURE SENSOR REQUIRED ONLY FOR COPPER WIRING INSTALLATIONS.

115-60-1

XVIII. S8600H INTERMITTENT PILOT SYSTEM TROUBLESHOOTING

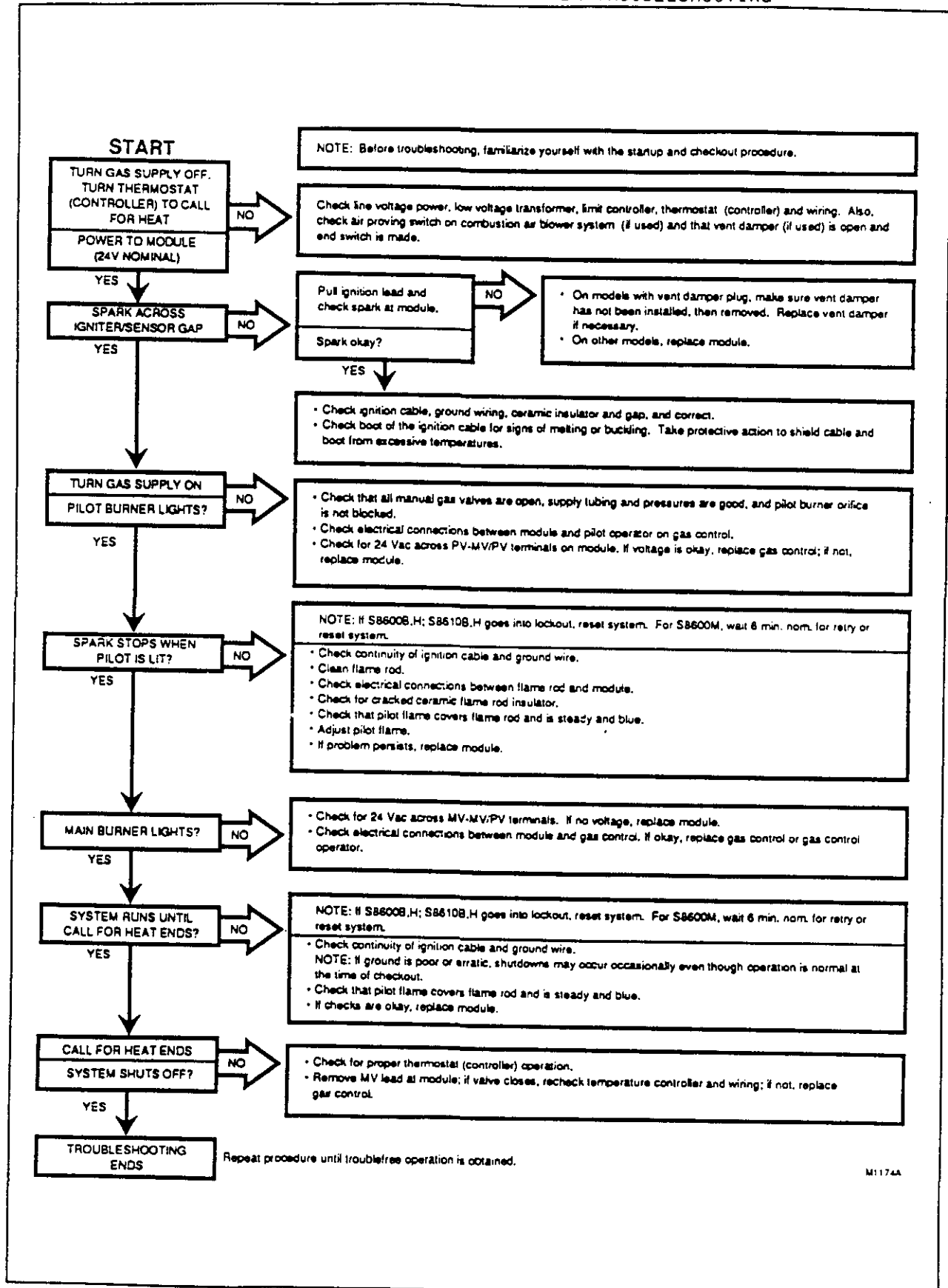

M1174A

XIX. COMMON VENTING REQUIREMENTS

For common venting this furnace with another gas burning appliance, the addition of Common Venting Kit is required. This kit is field installed by the installing contractor following the instructions packaged with the kit. It is a very simple procedure requiring only the removal and reinsertion of two screws and the reconnection of one wire. The kits that are required are detailed below:

TABLE 9

Furnace Model	Input Rating Btu/Hour	Common Venting Kit No.
IH60D36B,C IH85D48B,C IH115D48B,C	58,000 86,000 115,000	8620-005 8620-006 8620-006
IC60D36A,C IC85D42A,C IC115D48A,C	58,000 86,000 115,000	8620-011 8620-011 8620-011
IL85D42A,C IL115D48A,C IL145D60A,C	86,000 115,000 145,000	8620-006 8620-006 8620-005

There are some minimum specifications that apply to the common venting system design. These are outlined below with additional reference made to the illustrations as shown:

TABLE 10

Furnace Model	Minimum Total Vent Height "H"	Furnace Vent Connector Sizes	Minimum Common Vent Pipe Connector	
			3" Water Heater	4" Water Heater
IH60D36B,C IH85D48B,C IH115D48B,C	8' 8' 8'	3" 3" 4"	4" 4" 5"	4" 4" 5"
IC60D36A,C IC85D42A,C IC115D48A,C	8' 8' 8'	3" 4" 4"	4" 4" 5"	4" 4" 5"
IL85D42A,C IL115D48A,C IL145D60A,C	8' 8' 8'	3" 4" 4"	4" 5" 5"	4" 5" 5"

See the following table illustrations for common venting arrangements:

TABLE 11

Furnace Model	Vented With 3" Water Heater	Vented With 4" Water Heater
IH60D36B,C IH85D48B,C IH115D48B,C	Fig. 21, 22 Fig. 21, 22 Fig. 25, 26	Fig. 23, 24 Fig. 23, 24 Fig. 25, 26
IC60D36A,C IC85D42A,C IC115D48A,C	Fig. 21, 22 Fig. 21, 22 Fig. 22, 23	Fig. 23, 24 Fig. 23, 24 Fig. 25, 26
IL85D42A,C IL115D48A,C IL145D60A,C	Fig. 21, 22 Fig. 25, 26 Fig. 25, 26	Fig. 23, 24 Fig. 25, 26 Fig. 25, 26

