

High Economy Gas Furnace USERS INFORMATION MANUAL

FOR YOUR SAFETY

Do not store or use gasoline or other flammable vapors and liquids in the vicinity of this or any other appliance.

WARNING: Improper installation, adjustment, alteration, service or maintenance can cause injury or property damage. Refer to this manual. For assistance or additional information consult a qualified installer, service agency or the gas supplier.

FOR YOUR SAFETY

WHAT TO DO IF YOU SMELL GAS

- Do not try to light any appliance.
- Do not touch any electrical switch; do not use any phone in your building.
- Immediately call your gas supplier from a neighbor's phone. Follow the gas supplier's instructions.
- If you cannot reach your gas supplier, call the fire department.



GENERAL

The warnings shown on the cover of this manual and the information on the following pages are very important and should be fully read and understood by the operator of this equipment. Please take the few minutes necessary to completely read this booklet, and if there are any questions when you are through, ask your installer to review them with you. Please retain this booklet for future reference.

CLEARANCES

There are certain minimum installation clearances from the furnace cabinet and sheet metal plenum attached to the top of the furnace to any combustible materials. These clearances for each model of furnace are shown on the furnace rating plate (located in the burner compartment) and are the responsibility of the furnace installer during the installation of the appliance.

It is the owner's responsibility to make sure these clearances are always maintained thereafter. Additionally, a minimum of 24 inches for serviceability of furnace is required from the front side of all models.

A furnace installed in an attic or other insulated space must be kept free and clear of insulating material. The furnace area should be examined when the furnace is installed or when any additional insulation is added. Some insulating materials may be combustible.

BE SURE TO OBSERVE THE FOLLOWING RULES:

- DO NOT** allow any cardboard, newspapers, or any other combustible material (this includes wood, 2x4's, etc.) within the above specified minimum clearances. This includes placing any combustibles on or against the sheet metal plenum attached to the top of the furnace.
- DO NOT** use this furnace if any part has been under water. Immediately call a qualified service technician to inspect the furnace and to replace any part of the control system and any gas control which has been under water.
- The furnace area is to be kept clear and free of combustible materials, solvents, painting supplies, and any other flammable vapors or liquids.

COMBUSTION AND VENTILATING AIR

Whether your furnace is installed in a closet, basement, garage or other location as dictated by the particular application, an adequate source of fresh outside air has been provided by the installer to allow proper combustion and venting of the products of combustion to the outside of the building.

It is again the responsibility of the owner to assure that this important flow of combustion and ventilating air is not obstructed from reaching the furnace.

Do not block or obstruct air openings on the furnace, air openings communicating with the area in which the furnace is installed, and the spacings around the furnace.

LIGHTING AND SHUTDOWN INSTRUCTIONS

Reference should be made to Figures 1 and 2 for general location of components referenced in the following "Lighting Instructions".

WARNING

Should overheating occur, or the gas supply fail to shut off, shut off the manual gas valve to the furnace before shutting off the electrical supply.

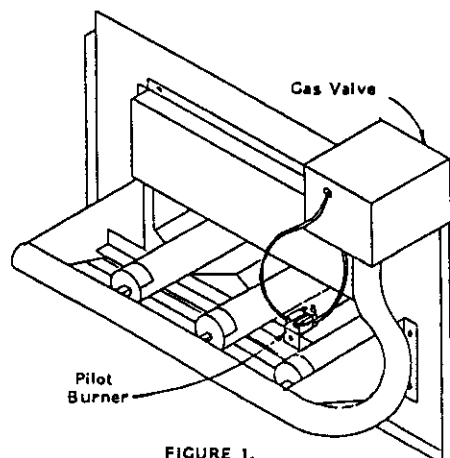

FIGURE 1.

LIGHTING INSTRUCTIONS

This unit is equipped with an automatic ignition system that will light the pilot when gas and electric power is supplied to unit and the thermostat calls for heat. After the pilot is proven the main burner will light.

CAUTION: Do not attempt to manually light the pilot.

- Turn gas cock knob on main gas valve within unit to "off" position. If external gas cock is used, turn to "off" position. Turn "off" main electrical supply and set thermostat to lowest setting.
Allow five minutes for any gas in unit to escape. L.P. gas being heavier than air may require forced ventilation.
- If furnace has a vent damper, it must be open during the 5 minute "off" cycle. It should automatically open when its switch is turned "off". Check instructions located at the shaft end of the damper (end opposite of control box).
- Turn gas cock knob on main gas valve and external gas cock to "on" position.
- Turn "on" main electrical supply to unit, and set the thermostat above the indicated temperature. Set "system" switch to "heat" or "auto" when combination heating and cooling thermostat is provided. Observe that pilot and main burner are operating properly.
- Set thermostat to desired temperature.
- If burner fails to ignite, repeat steps 1 through 4. If burner still fails to ignite, shut down the furnace and have qualified service personnel investigate the problem.

TO SHUT DOWN UNIT

- Turn thermostat to lowest setting.
- Turn "off" manual gas valve external to unit.
- Turn gas cock on main gas valve to "off" position.
- Turn "off" main electrical supply to unit.

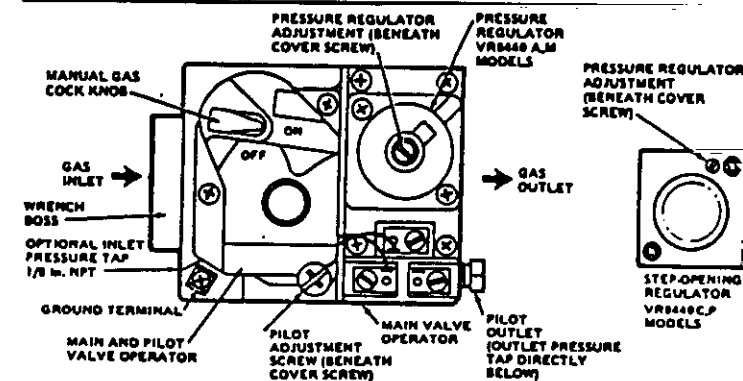

TOP VIEW OF VR8440 GAS CONTROL

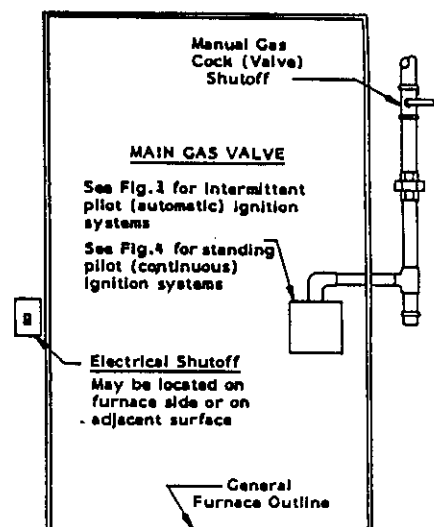

FIGURE 2.

AIR FILTERS

It is the owner's responsibility to check the condition of the air filters on at least a monthly basis when the furnace is in use and to clean or replace whenever it is necessary.

Permanent Type Filter (usually foam type) are washable. Use a solution of soapy water, followed by a rinse in clear water and then dried by tapping the frame against a solid object.

NEVER OPERATE A FURNACE WITHOUT A FILTER

**NEVER SUBSTITUTE A THROWAWAY (FIBERGLASS)
FOR A PERMANENT (FOAM) TYPE**

FIGURE 3.

FILTER SIZES FOR GAS FURNACES		
Model	Size	
86,000 Lo-Boy	(1) 18-3/4 x 20	P
115,000 Lo-Boy	(1) 22-3/4 x 20	P
145,000 Lo-Boy	(2) 13 x 20	P
All Hi-Boys	(1) 16 x 25	P
60,000 Counterflow	(1) 15 x 20	P
86,000 Counterflow	(2) 10 x 20	P
115,000 Counterflow	(1) 15 x 20 (1) 10 x 20	P P

P = Permanent

FILTER LOCATIONS--REMOVAL AND REPLACEMENT PROCEDURES - ALL HI-BOY FURNACES

To remove filters from ALL sectional Hi-Boys, first remove the upper burner door and then the lower blower compartment door by grasping top of door and pull up and away from the furnace. Then, remove the "S" clip and spring by pulling the clip towards the front of the furnace.

For right hand side filter location, relocate filter and retaining spring assembly to right side filter brackets.

For right hand side filter location on the 60,000 model furnaces, the optional filter rack is required because there is no room between the blower motor and right side of furnace to remove or install filter.

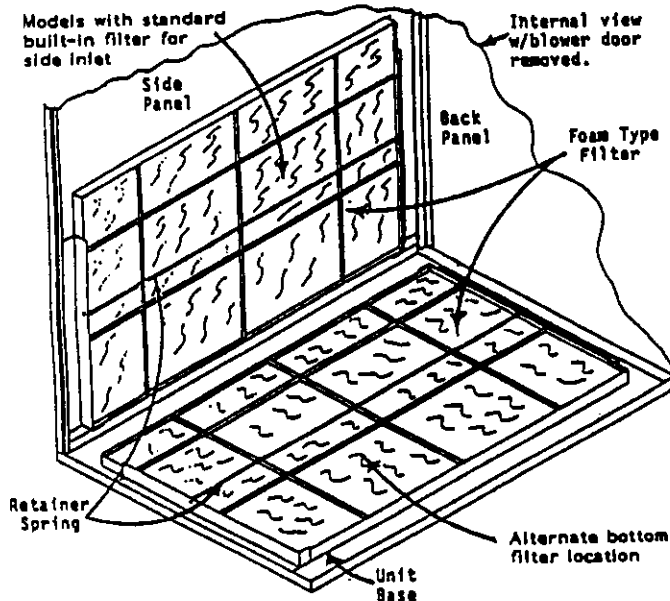

ALTERNATE BOTTOM FILTER LOCATION

All Hi-Boy models have an alternate bottom filter location as a standard feature to meet different installation requirements. See preceding illustration.

ALTERNATE SIDE FILTER RACK

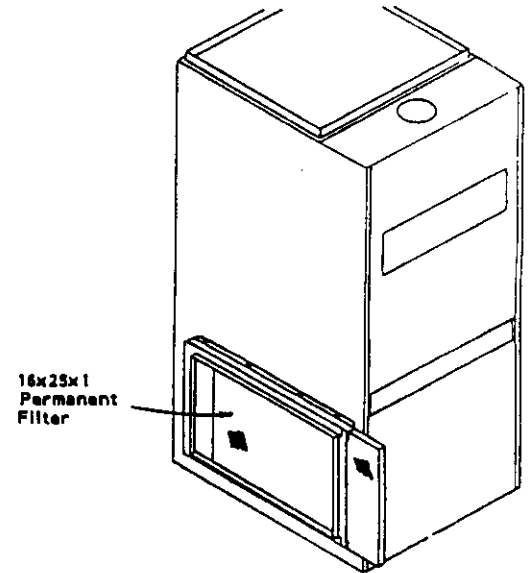

To remove filter from the optional external filter rack, grasp the exposed end of the filter and pull from the filter rack.

The location may vary, depending on which side the installer located the return air duct.

This filter is the permanent high velocity type foam filter which may be washed and used over and over. DO NOT replace it with a fiberglass filter of the same size.

To replace filter, reverse the above process.

FILTER LOCATIONS -- COUNTERFLOW MODELS

Counterflow models normally have filters installed in the return air plenum above the furnace unless a common return air/filter grille is used.

The electrical switch should be turned "off" before the front door to furnace is removed. After removing the front door, remove the left side filter door in the upper section of the furnace. Refer to the illustrations below for proper filter locations.

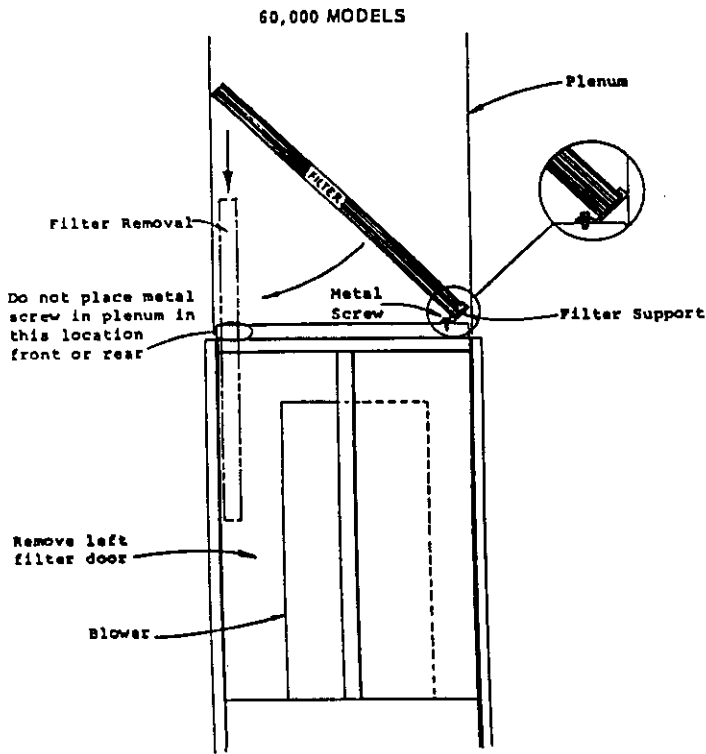

Attach filter support to furnace as shown with two sheet metal screws. The filter can be installed and removed through the left filter door.

FIGURE 4.

86,000 and 115,000 MODELS

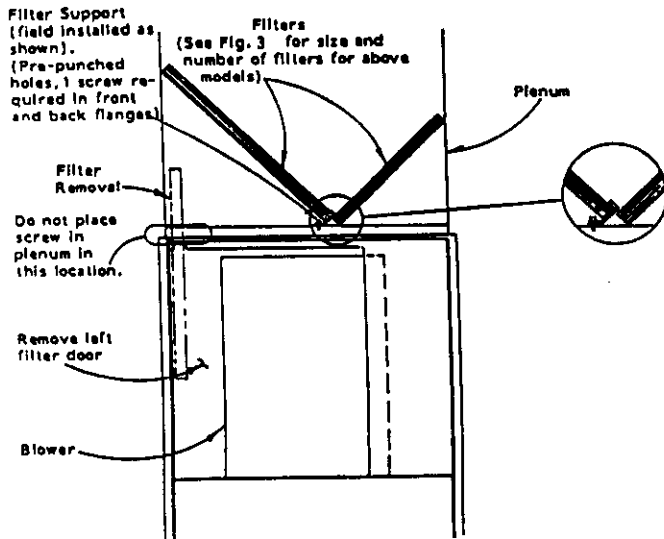

FIGURE 5.

FILTER LOCATIONS -- LO-BOY MODELS

Lo-Boy models have the filters installed in the return air cabinet section of the furnace. They are accessible from the rear of the furnace by removing the blower/filter access door. The electrical switch should be turned "off" prior to removing the access door.

**86,000 and 115,000 Models
Rear view with Blower/
Filter Access Door Removed**

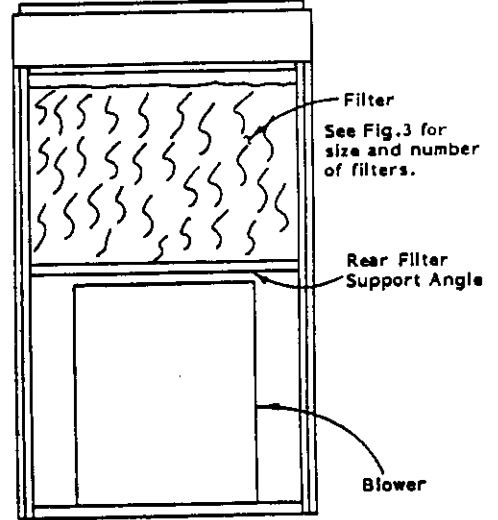

FIGURE 6.

**145,000 Models
Rear View with Blower/
Filter Access Door Removed**

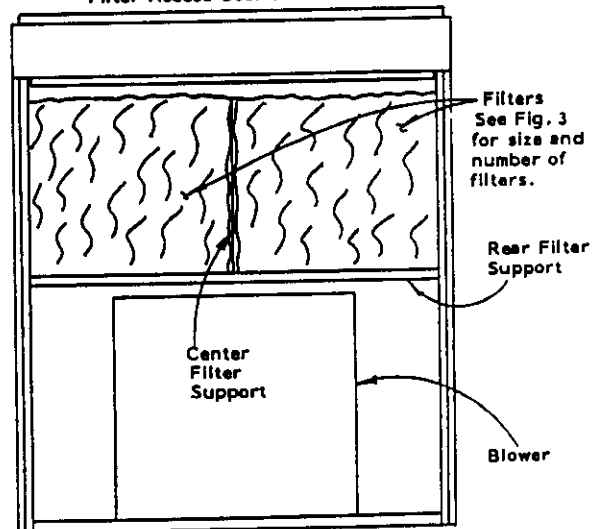

FIGURE 7.

LUBRICATION REQUIREMENTS

All models have permanently lubricated blower motors. The induced draft blower motor must be lubricated every six months with 3 to 4 drops of SAE20 motor oil.

FURNACE EXAMINATION

The furnace and the vent system (commonly called the flue pipe, smoke pipe, chimney, etc.) should be inspected yearly by a qualified service agency, generally prior to the heating season. Detailed procedures for this inspection are contained in the instructions booklet and should be handled by the qualified service agency only.

A general inspection of the furnace, the furnace area, and the venting system should be conducted on a regular basis by the owner/occupant. This review should include:

1. Assure that all flue product carrying areas external to the furnace (chimney, metal vent pipe, etc.) are clear and free of obstructions.
2. Make sure the furnace always has the minimum clearances as detailed in Figure 10. Special attention must be given to these items if any remodeling is done.
3. Make sure the vent connector (system) is in place, slopes upward and is physically sound without holes or excessive corrosion.
4. Reviewing that the return air duct connection(s) is physically sound, is sealed to the furnace casing, and terminates outside the space containing the furnace.
5. The physical support of the furnace is sound without sagging, cracks, gaps, etc. around the base.
6. Inspect for any obvious signs of deterioration of the furnace.
7. If the vent system incorporates a condensate drain, the drain must be inspected monthly for any blockage. If drain appears dirty or clogged, it must be removed and thoroughly washed out with warm water. Blockage of the drain can result in premature component failure.

Periodic examinations of the combustion area and vent system should also be conducted by the owner on a regular basis, preferably every month but at least every two months, during the heating season.

The following procedure should be followed for the periodic inspection as conducted by the owner:

1. Set the wall thermostat to the "off" position or lower the set point lever to a temperature well below the existing room temperature. Shut off electric power to the furnace. A switch should be mounted either on the outside of the furnace or adjacent to the furnace for this purpose.
2. Remove the furnace door exposing the burner compartment.
3. Using flashlight or trouble light, observe the burner compartment and where the burner(s) extend into the heat exchanger. There should be very minimal scaling or sooting in this area. Some loose debris may have fallen down on to the floor of the heat exchanger from the upper flue passageways, and this may be vacuumed out. Also observe the sides of the heat exchanger for "hot spots" due to improper burner alignment or overfiring and give particular attention to any area where it looks like there may be any deterioration from corrosion or rusting. Observe for any corrosion on the burners themselves. Should anything appear questionable, contact your service agency.
4. The pilot lights only when the thermostat calls for heat and the main burner lights within a few seconds thereafter. It is recommended that any observation of the pilot or main burner operation be done only with the burner compartment door in place and viewing through the combustion air slots. Any adjustments to the pilot flame should be done by a competent service agency.

5. Inspect the flue pipe the full distance from the furnace to chimney or to exit point from the building, observing for corrosion and possible leakage that might result in products of combustion entering the living area.

WARNING
**LEAKAGE OF PRODUCTS OF COMBUSTION
INTO THE LIVING AREA MAY RESULT
IN ASPHYXIATION.**

Any questionable flue pipe should be replaced. Considering its importance, it is relatively cheap insurance to protect your family. Consult your service agency.

6. Replace the burner compartment access doors by reversing the procedure as outlined under step 2 above.
7. Restore the electrical power to the furnace by turning the switch back on. Adjust the thermostat to call for heating operation.
8. Observe the main burners in operation viewing through the combustion air slots. The flame should be mostly "blue" with possibly a little "yellow" at the tips of the flames. The flames should be in the center of the heat exchanger compartments and not impinging on the heat exchanger surfaces themselves.
9. Observe the fire until the blower starts (there is a normal delay period until the heat exchanger warms up). There should be no change in the size or shape of the flame. If there is any wavering or blowing of the flame on the blower start-up, it is an indication of a possible leak in the heat exchanger. Turn off the main electrical switch to the furnace and the gas valve in the gas line leading to the furnace, and call your service agency.

